

HA17524P/FP

Switching Regulator Controller

HITACHI

Features

- Pulse width modulation (PWM)
- Wide oscillation frequency range: 450 kHz(typ)
- Low quiescent current: 5 mA typ
- Good line regulation (0.2% typ) and load regulation (0.4% typ)
- Independent output stages for 2 channels
- Wide external circuit applications including single-end and push-pull method
- Reference power source output stage and switching output stage include current limiting protection circuit.

Ordering Information

Type No.	Package
HA17524P	16 pin dual in line plastic(DP-16)
HA17524FP	16 pin flat plastic (FP-16DA)

Pin Arrangement

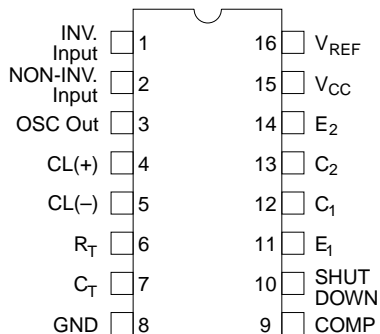

(Top View)

Functional Description

Principals of HA17524 Operation

The HA17524 switching regulator circuit, using pulse width modulation (PWM), is constructed as shown in figure 1.

Timing resistances R_T and timing capacitance C_T control the oscillation frequency. C_T is charged by a constant current generated by R_T . Ramp signals (saw-tooth waves) at the C_T terminal generated by this oscillator is available for reference input signal to comparator which control the pulse width.

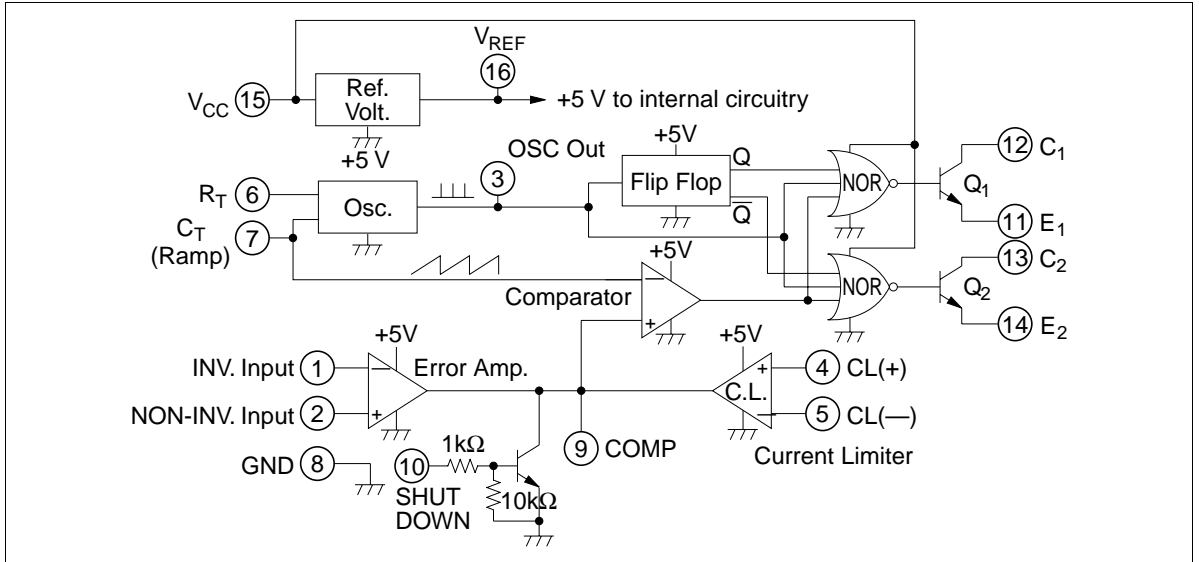

Figure 1 HA17524 Block Diagram

The reference voltage connects to the non-inverted or inverted input terminal of the error amplifier via resistance divider (figure 2).

The output voltage from the error amplifier is compared with the ramp signal capacitance C_T (figure 1). The comparator can provide a signal with modulated pulse width.

This signal, then, controls output transistors Q_1 and Q_2 , making an open loop to stabilize output voltage.

Outputs from the error amplifier, the current limiter, and the shut-down circuit are connected together at the comparator, so that an input signal from any one of these circuits can break the output stage.

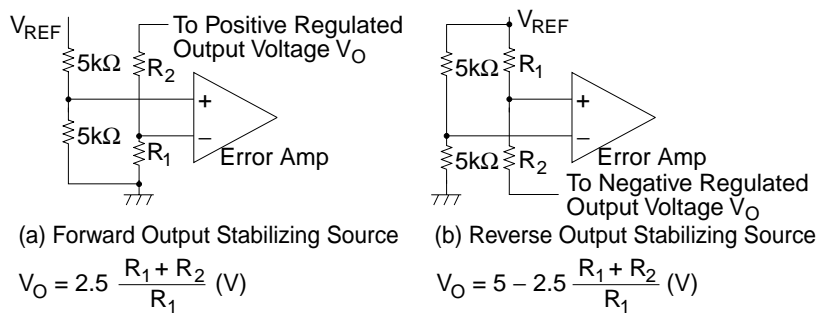

Figure 2 Error Amplifier Biasing

Blocks Description

Oscillator: The oscillation frequency f is calculated from the following equations. Figure 3 shows one example.

$$f = 1.15 / (R_T \cdot C_T)$$

$$R_T = 1.8\text{k} \text{ to } 100\text{k } \Omega$$

$$C_T = 0.001\mu \text{ to } 0.1\ \mu\text{F}$$

$$f = 140\text{ Hz} \text{ to } 500\text{ kHz}$$

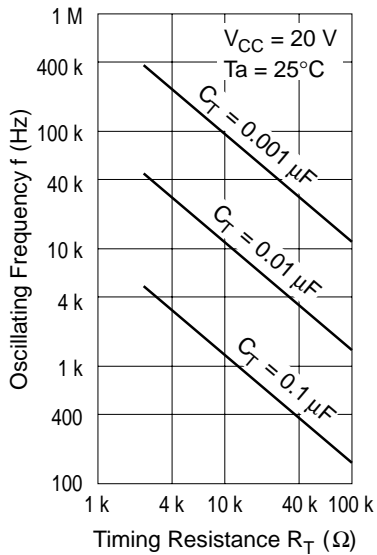

Figure 3 Oscillating Frequency vs Timing Resistance

Then the ramp wave shown in figure 4 is available at pin 7, C_T terminal, since C_T is charged by the constant current I generated by R_T .

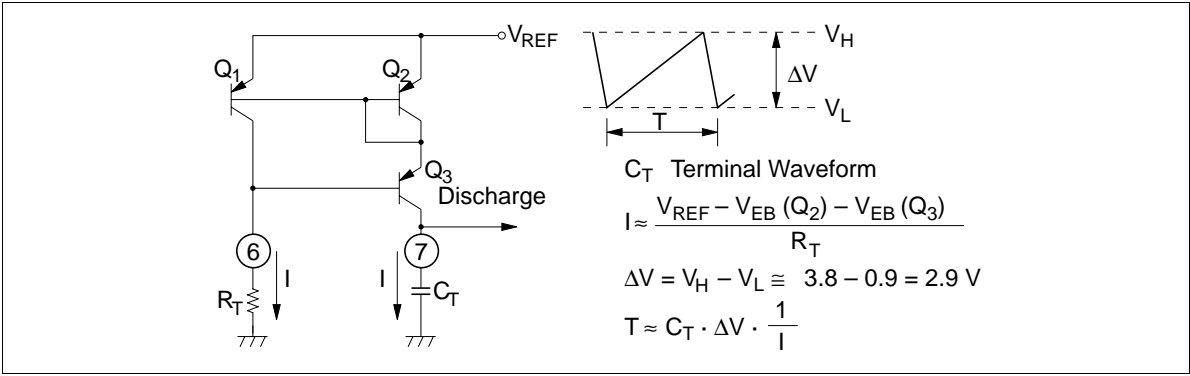

Figure 4 Oscillating Circuit and C_T Terminal Waveform

The oscillator output pulse signal is used as the flip flop clock pulse and as switching pulses for the output transistors, synchronous to the clock pulse.

The pulse-widths which can be controlled by the timing capacitor C_T as shown in figure 5, increases output dead time.

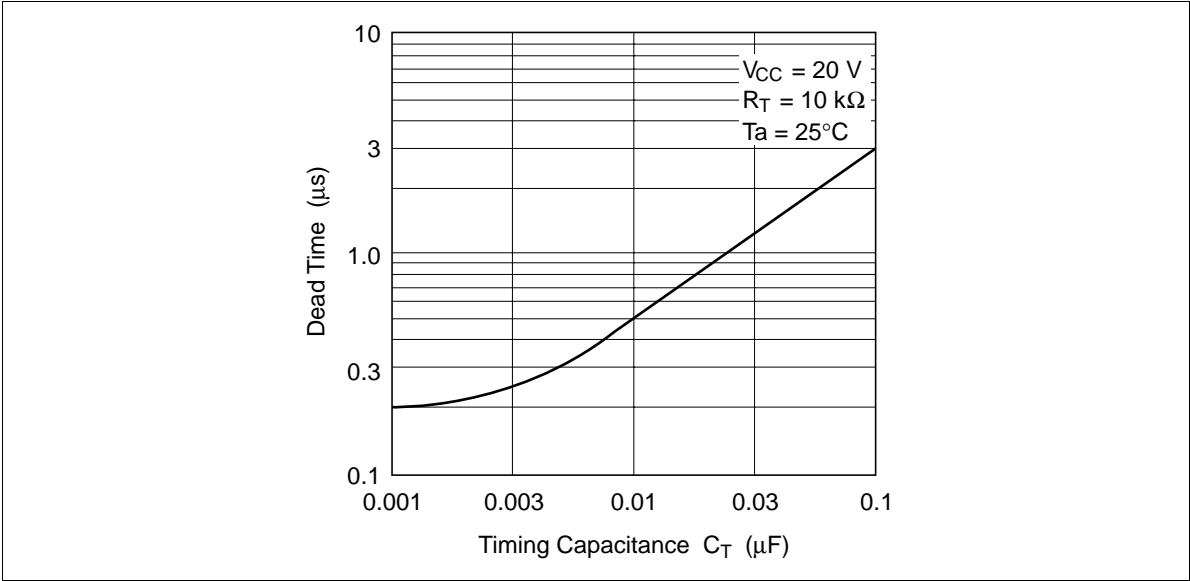

Figure 5 Dead Time vs Timing Capacitance

Reference Voltage: The built-in regulator (reference voltage: $V_{REF} = 5 \pm 0.4 \text{ V}$) can be used as a reference power supply for the error amplifier, which determines output voltage (V_{OUT}). It is also connected as a bias source for another circuits in IC.

Error Amplifier: Figure 2 shows error amplifier biasing, applied input voltage must be set within the range of common-mode input voltage (1.8 V to 3.4 V). Inserting a resistor and capacitor between phase compensation terminal (pin 9) and GND in series provides phase compensation.

Current Limiter: The sense amplifier threshold voltage (V_S) for the current limiter is:

$$\begin{aligned} V_S &= V_{BE}(Q_1) + I_1 R_2 - V_{BE}(Q_2) \\ &= I_1 R_2 \\ &= 200 \text{ mV typ} \end{aligned}$$

At the current limiter sense amp shown in figure 6, when $V^+ - V^- > 200 \text{ mV}$, Q_1 turns on, phase compensation terminal becomes low and the output switching element is cut off.

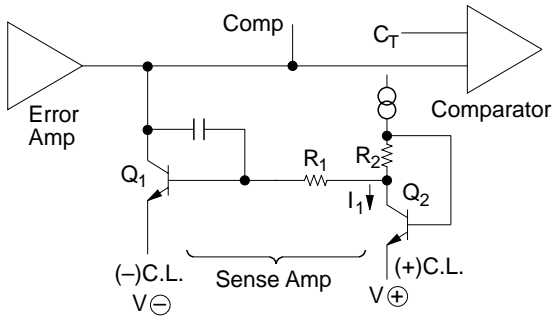

Figure 6 Current Limiter Sense Amplifier

Figure 7 shows an example of detecting current limit. The input voltage range is -0.7 V to $+1.0 \text{ V}$; The current limit detection output is provided from GND line.

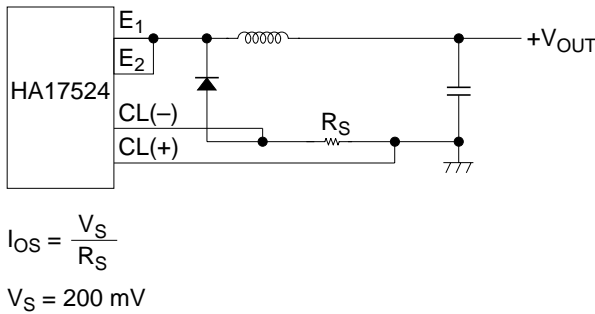

Figure 7 Current Limit Detector Example Operating Waveforms

Operating Waveforms

Figure 9 shows operating waveforms at every part, when stepdown voltage type chopper switching regulator (figure 8) is used. Operating condition are as follows: $f = 20 \text{ kHz}$, $V_{\text{OUT}} = 5 \text{ V}$. At the output section, two channels are connected in parallel. Operating waveforms inside the IC are also shown.

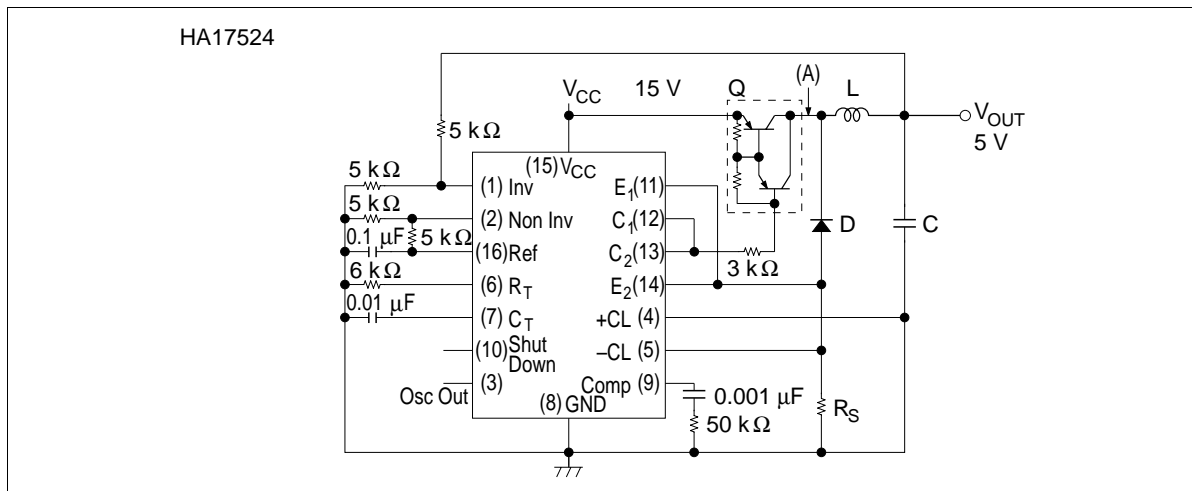

Figure 8 Stepdown Voltage Type Chopper Switching Regulator

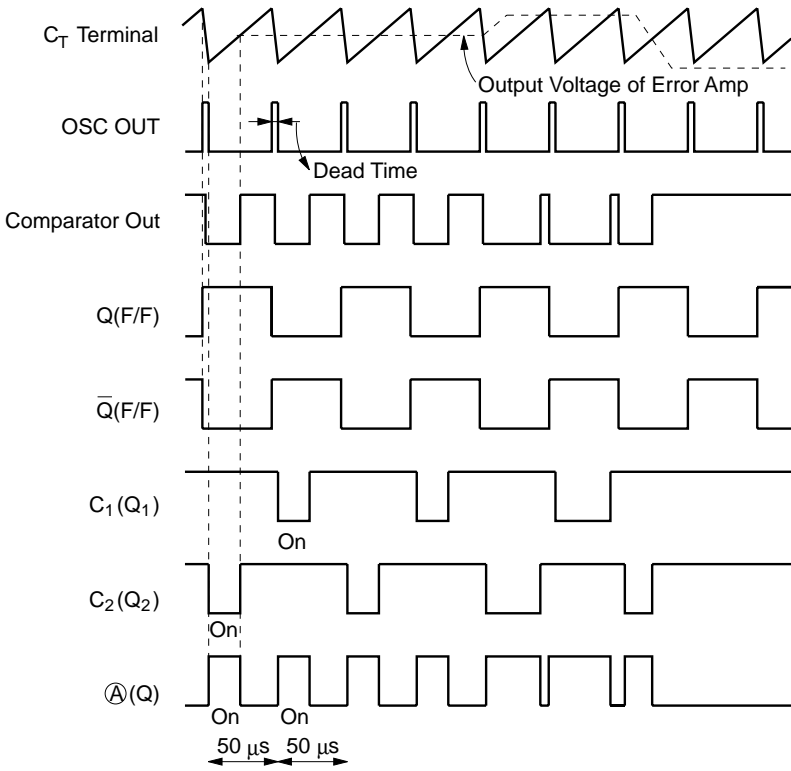

Figure 9 Operating Waveforms

Circuit Applications

Simplified inverting Regulator: Figure 10 shows the circuit configuration of HA17524 inverting regulator for light load ($V_{OUT} = -5\text{ V}$)

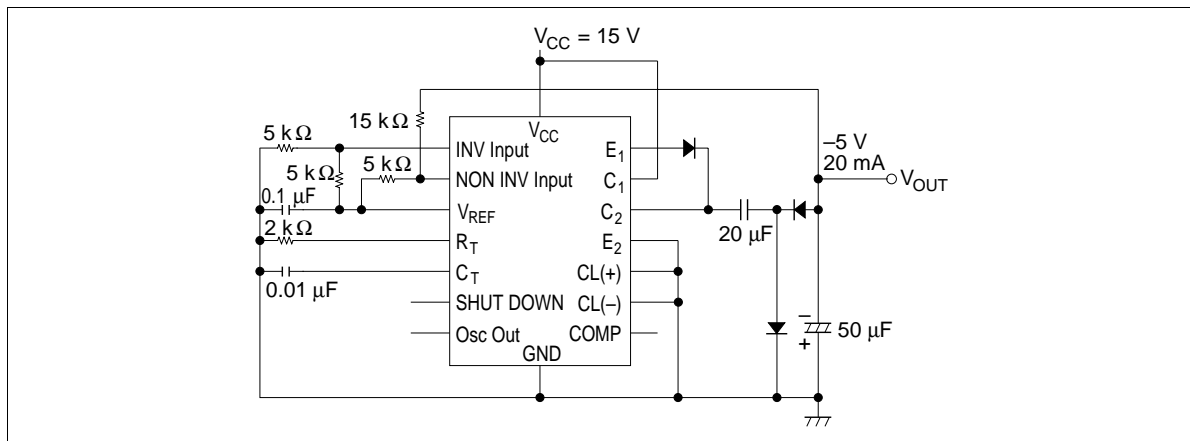

Figure 10 Simple Polarity Conversion

Tracking Switching Regulator: Figure 11 shows the circuit configuration of a tracking regulator that uses a transformer. ($V_{OUT} = \pm 15\text{ V}$)

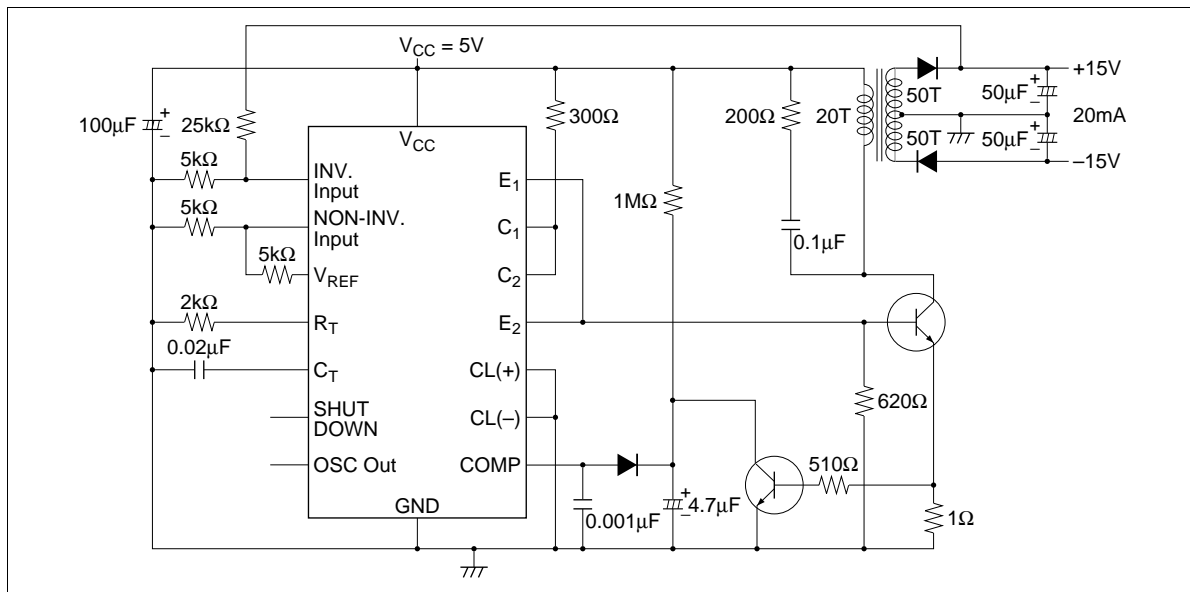

Figure 11 Tracking Switching Regulator

Push Pull Switching Regulator: Figure 12 shows the circuit configuration of push-pull switching regulator that uses transformer. This system is suited for high power. Output transistors inside HA17524 can drive external switching transistors.

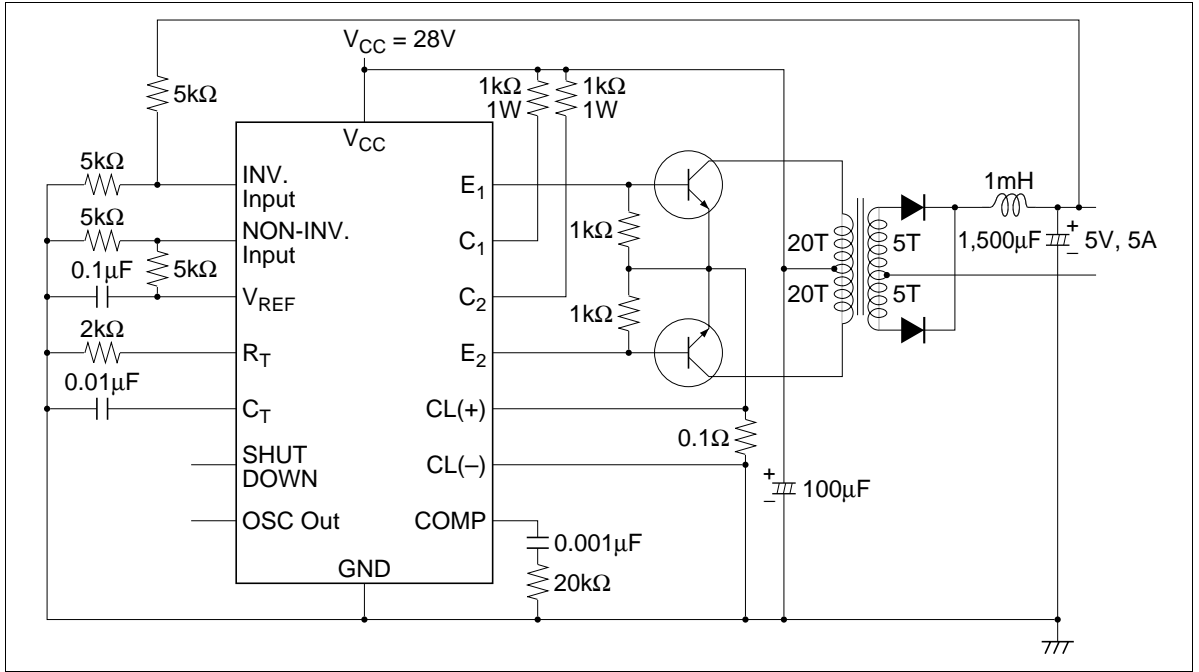

Figure 12 Push-Pull Switching Regulator

Note

Compared with conventional series regulators, switching regulators generate high frequency noise by switching current quickly. To reduce noise

1. As a general rule, insert line filter to reduce noise at the input.
2. To reduce noise at the output:
 - a. Twist output wiring together.
 - b. Do not bundle power source and output wiring.
 - c. Insert capacitor should be inserted at the load side.
 - d. Ground the power frame.
3. When choosing external parts (external switching transistor, diode, coil, etc) consider their capacitance and characteristics.

Absolute Maximum Ratings (Unless otherwise specified, $T_a = +25^\circ\text{C}$)

Item	Symbol	Rating	Unit	Note
Supply voltage	V_{CC}	40	V	1, 2
Collector output current	I_C	100	mA	
Reference output current	I_{REF}	50	mA	
Current through C_T terminal	I_{CT}	5	mA	
Continuous total power dissipation	P_T	600	mW	3
Operating free-air temperature range	T_{opr}	-20 to +75	$^\circ\text{C}$	
Storage temperature range	T_{stg}	-55 to +125	$^\circ\text{C}$	

Notes: 1. With respect to network ground terminal

2. The reference voltage can be given by connecting the V_{CC} and 5 V reference output pins both to the supply voltage. In this configuration, $V_{CC} = 6\text{ V}$ max.

3. HA17524P: Value at $T_a \leq 52.7^\circ\text{C}$, If $T_a > 52.7^\circ\text{C}$, derate by $8.3\text{ mW}/^\circ\text{C}$

Electrical Characteristics ($V_{CC} = 20\text{ V}$, $f = 20\text{ kHz}$, $T_a = 25^\circ\text{C}$)

Item		Symbol	Min	Typ	Max	Unit	Test Conditions
Regulator	Output voltage	V_{REF}	4.6	5.0	5.4	V	
	Input regulation	δV_{OLine}	—	10	30	mV	$V_{CC} = 8\text{ to }40\text{ V}$
	Ripple rejection	R_{REJ}	—	66	—	dB	$f = 120\text{ Hz}$
	Output regulation	δV_{OLoad}	—	20	50	mV	$I_{out} = 0\text{ to }20\text{ mA}$
	Output voltage change with output temperature	$\delta V_O / \delta T_a$	—	0.3	1.0	%	$T_a = 0\text{ to }+70^\circ\text{C}$
			—	0.4	1.36	%	$T_a = -20\text{ to }+75^\circ\text{C}$
Short-circuit output current (Note)	I_{OS}	—	100	—	mA	$V_{REF} = 0$	
Error amplifier	Input offset voltage	V_{IO}	—	2	10	mV	$V_{IC} = 2.5\text{ V}$
	Input bias current	I_I	—	2	10	μA	$V_{IC} = 2.5\text{ V}$
	Open-loop voltage gain	A_{VD}	—	60	—	dB	
	Common-mode input voltage range	V_{CM}	1.8 to 3.4	—	—	V	$T_a = 25^\circ\text{C}$
	Common-mode Rejection ratio	CMR	—	70	—	dB	
	Unity-gain bandwidth	BW	—	3	—	MHz	
	Output swing	V_{OPP}	0.5	—	3.8	V	
Oscillator	OSC frequency	f	—	450	—	kHz	$C_T = 0.001\ \mu\text{F}$, $R_T = 2\ \text{k}\Omega$
	Standard deviation of frequency	Δf	—	5	—	%	$V_{CC} = 8\text{ to }40\text{ V}$, $R_T = 1.8\text{ to }100\ \text{k}\Omega$, $C = \text{Const}$
	Frequency stability	δf_{Line}	—	—	1.0	%	$V_{CC} = 8\text{ to }40\text{ V}$
			—	5.0	10	%	$T_a = 0\text{ to }+70^\circ\text{C}$
			—	5.0	13.6	%	$T_a = -20\text{ to }+75^\circ\text{C}$
	Output amplitude	$V_{3(\text{peak})}$	—	3.5	—	V	Pin 3
Output pulse width	T_P	—	0.5	—	μs	$C_T = 0.01\ \mu\text{F}$, Pin 3	
Comparator	Maximum duty cycle	Dmax	45	—	—	%	
	Threshold voltage	$V_{th\ 0}$	—	1.0	—	V	Duty cycle = 0
		$V_{th\ max}$	—	3.5	—	V	Duty cycle = max
Input bias current	I_I	—	-1	—	μA		

Note: Duration of the short-circuit should not exceed one second.

Electrical Characteristics ($V_{CC} = 20\text{ V}$, $f = 20\text{ kHz}$, $T_a = 25^\circ\text{C}$) (cont)

Item		Symbol	Min	Typ	Max	Unit	Test Conditions
Current limiter	Input voltage range	V_{IS}	-0.7 to +1.0	—	—	V	
	Sense voltage	V_S	180	200	220	mV	$V(\text{Pin } 9) = 2\text{ V}$, $T_a = 25^\circ\text{C}$ $V(\text{Pin } 2)$ $-V(\text{Pin } 1) \geq 50\text{ mV}$
	Sensevoltage change with temperature	$\delta V_S/\delta T_a$	—	0.2	—	mV/°C	$T_a = -20\text{ to }+75^\circ\text{C}$
Output	Collector-emitter breakdown voltage	V_{CE}	40	—	—	V	
	Collector off-state current	I_{Leak}	—	0.01	50	μA	$V_{CE} = 40\text{ V}$
	Collector-emitter saturation voltage	$V_{CE(sat)}$	—	1	2	V	$I_C = 50\text{ mA}$
	Emitter output voltage	V_E	17	18	—	V	$V_{CC} = 20\text{ V}$, $I_E = -250\text{ }\mu\text{A}$
	Rise time	t_r	—	0.2	—	μs	$R_C = 2\text{ k}\Omega$
	Fall time	t_f	—	0.1	—	μs	
Total device	Standby current	I_{ST}	—	5.0	10	mA	$V_{CC} = 40\text{ V}$, $V_2 = 2\text{ V}$, Pins 1, 4, 7, 8, 9, 11, 14 grounded, All other pins open

Characteristic Curves

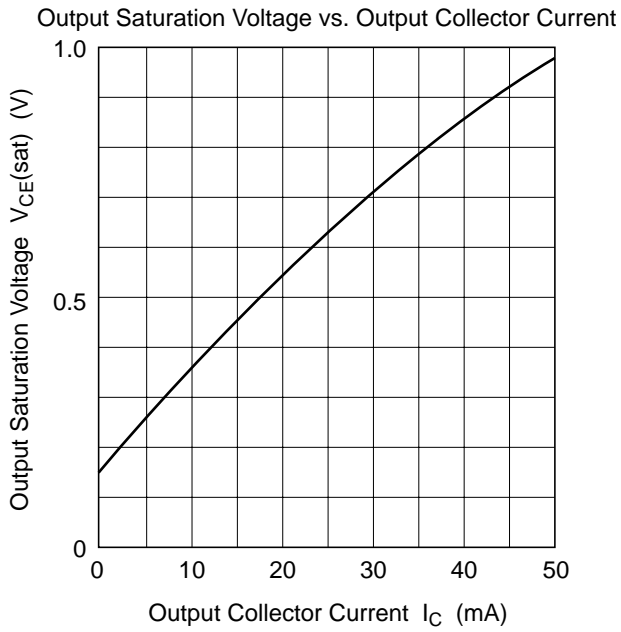
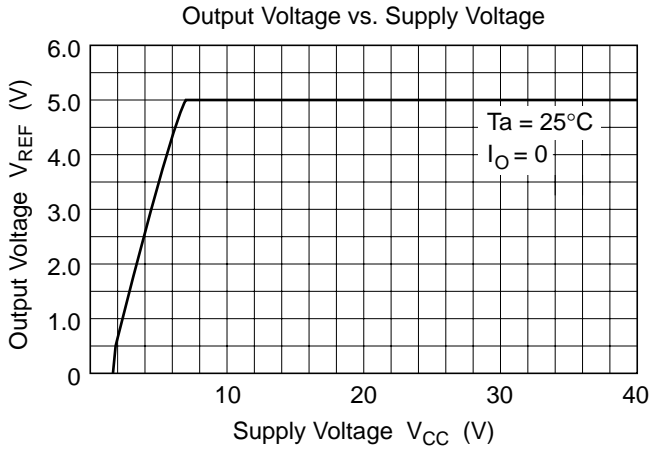

Oscillating Frequency vs. Timing Resistance

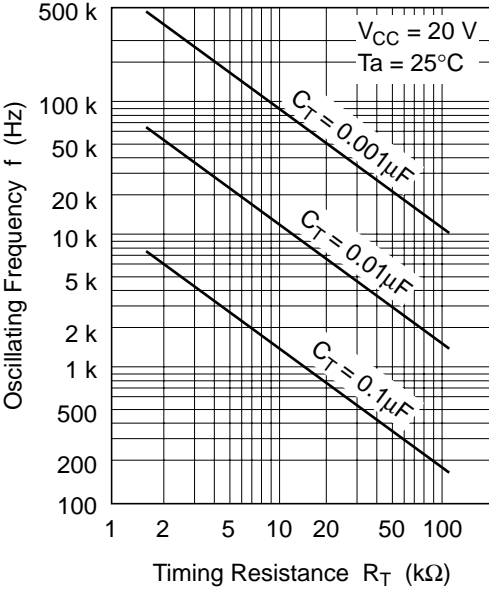

Output Voltage vs. Ambient Temperature

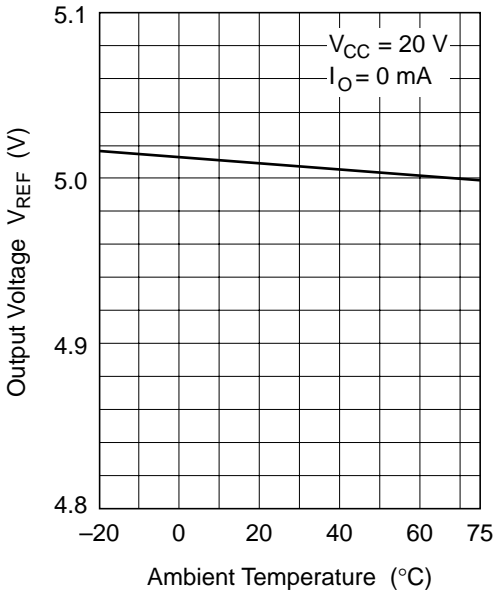

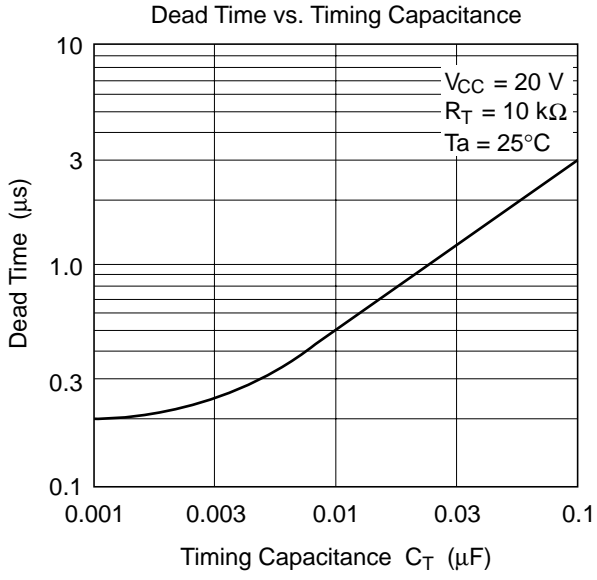

Package Dimensions

Unit: mm

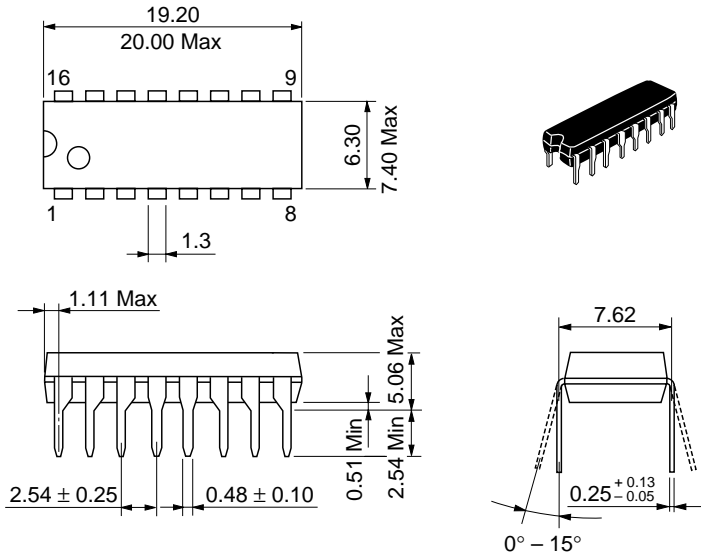

Hitachi Code	DP-16
JEDEC	Conforms
EIAJ	Conforms
Mass (reference value)	1.07 g

Unit: mm

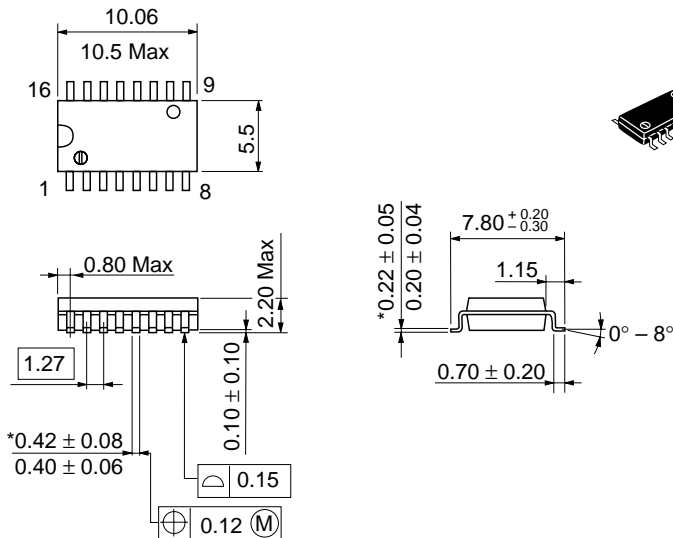

Hitachi Code	FP-16DA
JEDEC	—
EIAJ	Conforms
Mass (reference value)	0.24 g

*Dimension including the plating thickness
Base material dimension

Cautions

1. Hitachi neither warrants nor grants licenses of any rights of Hitachi's or any third party's patent, copyright, trademark, or other intellectual property rights for information contained in this document. Hitachi bears no responsibility for problems that may arise with third party's rights, including intellectual property rights, in connection with use of the information contained in this document.
2. Products and product specifications may be subject to change without notice. Confirm that you have received the latest product standards or specifications before final design, purchase or use.
3. Hitachi makes every attempt to ensure that its products are of high quality and reliability. However, contact Hitachi's sales office before using the product in an application that demands especially high quality and reliability or where its failure or malfunction may directly threaten human life or cause risk of bodily injury, such as aerospace, aeronautics, nuclear power, combustion control, transportation, traffic, safety equipment or medical equipment for life support.
4. Design your application so that the product is used within the ranges guaranteed by Hitachi particularly for maximum rating, operating supply voltage range, heat radiation characteristics, installation conditions and other characteristics. Hitachi bears no responsibility for failure or damage when used beyond the guaranteed ranges. Even within the guaranteed ranges, consider normally foreseeable failure rates or failure modes in semiconductor devices and employ systemic measures such as fail-safes, so that the equipment incorporating Hitachi product does not cause bodily injury, fire or other consequential damage due to operation of the Hitachi product.
5. This product is not designed to be radiation resistant.
6. No one is permitted to reproduce or duplicate, in any form, the whole or part of this document without written approval from Hitachi.
7. Contact Hitachi's sales office for any questions regarding this document or Hitachi semiconductor products.

HITACHI

Hitachi, Ltd.

Semiconductor & Integrated Circuits.

Nippon Bldg., 2-6-2, Ohite-machi, Chiyoda-ku, Tokyo 100-0004, Japan

Tel: Tokyo (03) 3270-2111 Fax: (03) 3270-5109

URL NorthAmerica : <http://semiconductor.hitachi.com/>
Europe : <http://www.hitachi-eu.com/hel/ecg>
Asia (Singapore) : <http://www.has.hitachi.com.sg/grp3/sicd/index.htm>
Asia (Taiwan) : http://www.hitachi.com.tw/E/Product/SICD_Frame.htm
Asia (HongKong) : <http://www.hitachi.com.hk/eng/bo/grp3/index.htm>
Japan : <http://www.hitachi.co.jp/Sicd/indx.htm>

For further information write to:

Hitachi Semiconductor
(America) Inc.
179 East Tasman Drive,
San Jose, CA 95134
Tel: <1> (408) 433-1990
Fax: <1> (408) 433-0223

Hitachi Europe GmbH
Electronic components Group
Dornacher Straße 3
D-85622 Feldkirchen, Munich
Germany
Tel: <49> (89) 9 9180-0
Fax: <49> (89) 9 29 30 00

Hitachi Europe Ltd.
Electronic Components Group.
Whitebrook Park
Lower Cookham Road
Maidenhead
Berkshire SL6 8YA, United Kingdom
Tel: <44> (1628) 585000
Fax: <44> (1628) 778322

Hitachi Asia Pte. Ltd.
16 Collyer Quay #20-00
Hitachi Tower
Singapore 049318
Tel: 535-2100
Fax: 535-1533

Hitachi Asia Ltd.
Taipei Branch Office
3F, Hung Kuo Building, No.167,
Tun-Hwa North Road, Taipei (105)
Tel: <886> (2) 2718-3666
Fax: <886> (2) 2718-8180

Hitachi Asia (Hong Kong) Ltd.
Group III (Electronic Components)
7/F., North Tower, World Finance Centre,
Harbour City, Canton Road, Tsim Sha Tsui,
Kowloon, Hong Kong
Tel: <852> (2) 735 9218
Fax: <852> (2) 730 0281
Telex: 40815 HITEC HX

Copyright ' Hitachi, Ltd., 1998. All rights reserved. Printed in Japan.

HITACHI

This datasheet has been downloaded from:

www.DatasheetCatalog.com

Datasheets for electronic components.



LittleDiode supplies new, hard to find or obsolete electronic components and semiconductors all over the world.

With over two million different components listed you are sure to find the part you need.

Feel free to visit us today at our online store:

LittleDiode.com

Looking forward to providing you with the best possible service.