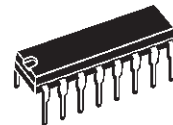


SERIAL INTERFACE CODEC/FILTER

- COMPLETE CODEC AND FILTERING SYSTEM (DEVICE) INCLUDING:
 - Transmit high-pass and low-pass filtering.
 - Receive low-pass filter with $\sin x/x$ correction.
 - Active RC noise filters
 - μ -law or A-law compatible COder and DECoder.
 - Internal precision voltage reference.
 - Serial I/O interface.
 - Internal auto-zero circuitry.
- A-LAW 16 PINS (ETC5057FN, 20 PINS)
- μ -LAW WITHOUT SIGNALING, 16 PINS (ETC5054FN, 20 PINS)
- MEETS OR EXCEEDS ALL D3/D4 AND CCITT SPECIFICATIONS
- $\pm 5V$ OPERATION
- LOW OPERATING POWER - TYPICALLY 60 mW
- POWER-DOWN STANDBY MODE - TYPICALLY 3 mW
- AUTOMATIC POWER-DOWN
- TTL OR CMOS COMPATIBLE DIGITAL INTERFACES
- MAXIMIZES LINE INTERFACE CARD CIRCUIT DENSITY
- 0 to 70°C OPERATION

DESCRIPTION

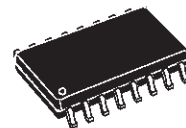
The ETC5057/ETC5054 family consists of A-law and μ -law monolithic PCM CODEC/filters utilizing the A/D and D/A conversion architecture shown in the block diagram below, and a serial PCM interface. The devices are fabricated using double-poly CMOS process. The encode portion of each device consists of an input gain adjust amplifier, an active RC pre-filter which eliminates very high frequency noise prior to entering a switched-capacitor band-pass filter that rejects signals below 200 Hz and above 3400 Hz. Also included are auto-zero circuitry and a companding coder which samples the filtered signal and encodes it in the companded A-law or μ -law PCM format. The decode portion of each device consists of an expanding decoder, which reconstructs the analog signal from the companded A-law or μ -law code, a low-pass filter which corrects for the $\sin x/x$ response of the decoder output and rejects signals above 3400 Hz and is followed by a single-ended power amplifier capable of driving low impedance loads. The devices require 1.536 MHz, 1.544



DIP16 (Plastic)

ORDERING NUMBERS:

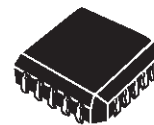
ETC5057N
ETC5054N



SO16 (Wide)

ORDERING NUMBERS:

ETC5057D
ETC5054D



PLCC20

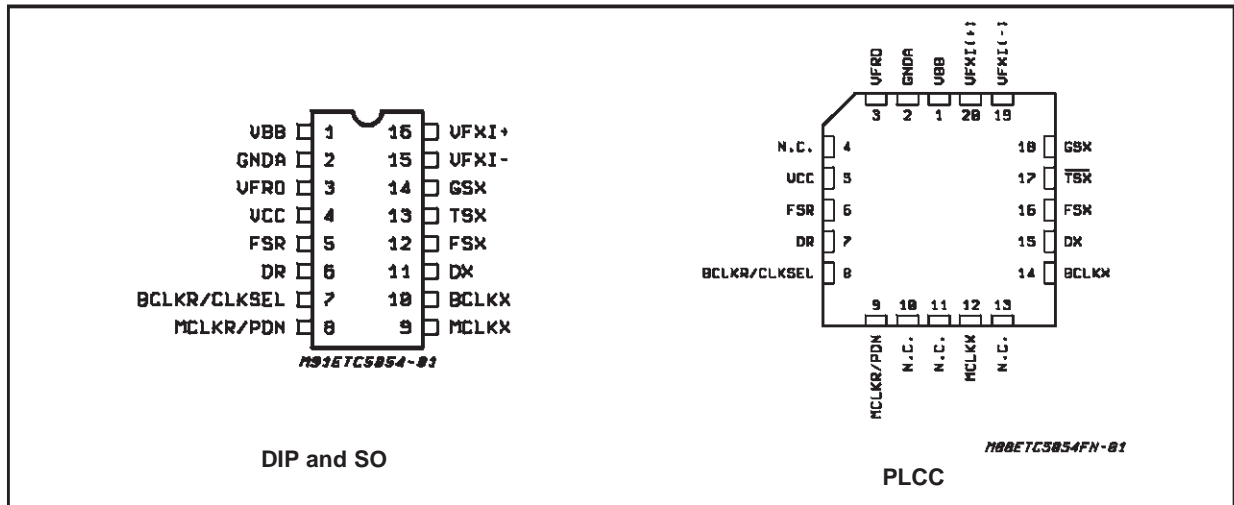
ORDERING NUMBERS:

ETC5057FN
ETC5054FN

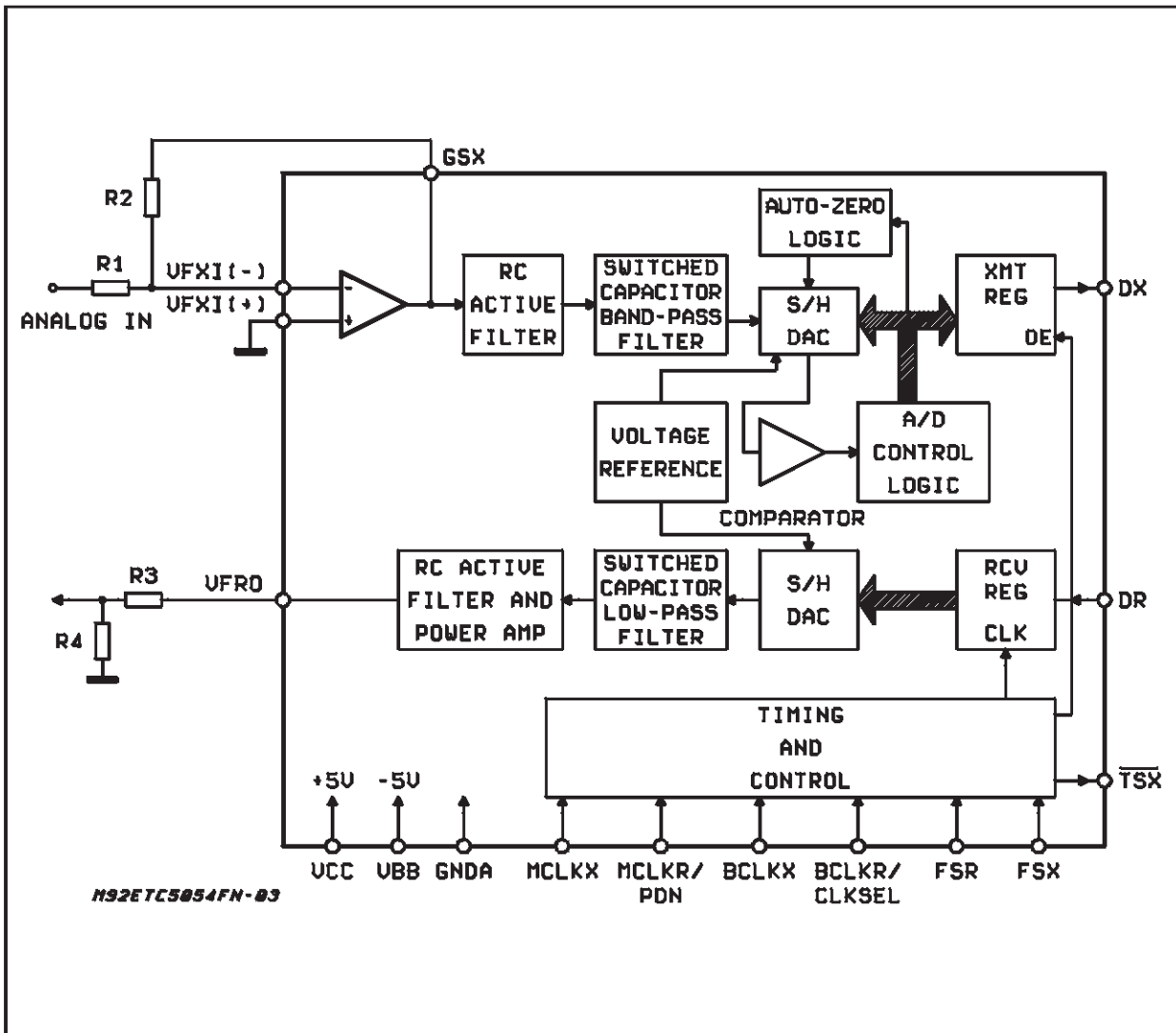
MHz, or 2.048 MHz transmit and receive master clocks, which may be asynchronous, transmit and receive bit clocks which may vary from 64 kHz to 2.048 MHz, and transmit and receive frame sync pulses. The timing of the frame sync pulses and PCM data is compatible with both industry standard formats.

ETC5054 - ETC5057

PIN CONNECTIONS (Top view)



BLOCK DIAGRAM



PIN DESCRIPTION

Name	Pin Type *	N° DIP and SO	N° PLCC (**)	Function	Description
V _{BB}	S	1	1	Negative Power Supply	V _{BB} = - 5 V ± 5 %.
GNDA	GND	2	2	Analog Ground	All signals are referenced to this pin.
VF _{RO}	O	3	3	Receive Filter Output	Analog Output of the Receive Filter
V _{CC}	S	4	5	Positive Power Supply	V _{CC} = + 5 V ± 5 %.
FS _R	I	5	6	Receive Frame Sync Pulse	Enables BCLK _R to shift PCM data into D _R . FS _R is an 8kHz pulse train. See figures 1, 2 and 3 for timing details.
D _R	I	6	7	Receive Data Input	PCM data is shifted into D _R following the FS _R leading edge.
BCLK _R /CLKSEL	I	7	8	Shift-in Clock	Shifts data into D _R after the FS _R leading edge. May vary from 64 kHz to 2.048 MHz. Alternatively, may be a logic input which selects either 1.536 MHz/1.544 MHz or 2.048 MHz for master clock in synchronous mode and BCLK _X is used for both transmit and receive directions (see table 1). This input has an internal pull-up.
MCLK _R /PDN	I	8	9	Receive Master Clock	Must be 1.536 MHz, 1.544 MHz or 2.048 MHz. May be asynchronous with MCLK _X , but should be synchronous with MCLK _X for best performance. When MCLK _R is connected continuously low, MCLK _X is selected for all internal timing. When MCLK _R is connected continuously high, the device is powered down.
MCLK _X	I	9	12	Transmit Master Clock	Must be 1.536 MHz, 1.544 MHz or 2.048 MHz. May be asynchronous with MCLK _R .
BCLK _X	I	10	14	Shift-out Clock	Shifts out the PCM data on D _X . May vary from 64 kHz to 2.048 MHz, but must be synchronous with MCLK _X .
D _X	O	11	15	Transmit Data Output	The TRI-STATE® PCM data output which is enabled by FS _X .
FS _X	I	12	16	Transmit Frame Sync Pulse	Enables BCLK _X to shift out the PCM data on D _X . FS _X is an 8 kHz pulse train. See figures 1, 2 and 3 for timing details.
$\overline{\text{TS}}_X$	O	13	17	Transmit Time Slot	Open drain output which pulses low during the encoder time slot. Recommended to be grounded if not used.
GS _X	O	14	18	Gain Set	Analog output of the transmit input amplifier. Used to set gain externally.
VF _{XI} ⁻	I	15	19	Inverting Amplifier Input	Inverting Input of the Transmit Input Amplifier.
VF _{XI} ⁺	I	16	20	Non-inverting Amplifier Input	Non-inverting Input of the Transmit Input Amplifier.

(*) I: Input, O: Output, S: Power Supply

(**) Pins 4,10,11 and 13 are not connected

TRI-STATE® is a trademark of National Semiconductor Corp.

FUNCTIONAL DESCRIPTION

POWER-UP

When power is first applied, power-on reset circuitry initializes the device and places it into the power-down mode. All non-essential circuits are deactivated and the D_X and V_{FRO} outputs are put in high impedance states. To power-up the device, a logical low level or clock must be applied to the MCLK_R/PDN pin and FS_X and/or FS_R pulses must be present. Thus, 2 power-down control modes are available. The first is to pull the MCLK_R/PDN pin high ; the alternative is to hold both FS_X and FS_R inputs continuously low. The device will power-down approximately 2 ms after the last FS_X or FS_R pulse. Power-up will occur on the first FS_X or FS_R pulse. The TRI-STATE PCM data output, D_X, will remain in the high impedance state until the second FS_X pulse.

SYNCHRONOUS OPERATION

For synchronous operation, the same master clock and bit clock should be used for both the transmit and receive directions. In this mode, a clock must be applied to MCLK_X and the MCLK_R/PDN pin can be used as a power-down control. A low level on MCLK_R/PDN powers up the device and a high level powers down the device. In either case, MCLK_X will be selected as the master clock for both the transmit and receive circuits. A bit clock must also be applied to BCLK_X and the BCLK_R/CKSEL can be used to select the proper internal divider for a master clock of 1.536 MHz, 1.544 MHz or 2.048 MHz. For 1.544 MHz operation, the device automatically compensates for the 193rd clock pulse each frame. With a fixed level on the BCLK_R/CLKSEL pin, BCLK_X will be selected as the bit clock for both the transmit and receive directions. Table 1 indicates the frequencies of operation which can be selected, depending on the state of BCLK_R/CLKSEL. In this synchronous mode, the bit clock, BCLK_X, may be from 64 kHz to 2.048 MHz, but must be synchronous with MCLK_X.

Each FS_X pulse begins the encoding cycle and the PCM data from the previous encode cycle is shifted out of the enabled D_X output on the positive edge of BCLK_X. After 8 bit clock periods, the

TRI-STATE D_X output is returned to a high impedance state. With and FS_R pulse, PCM data is latched via the D_R input on the negative edge of BCLK_X (or BCLK_R if running). FS_X and FS_R must be synchronous with MCLK_{X/R}.

ASYNCHRONOUS OPERATION

For asynchronous operation, separate transmit and receive clocks may be applied, MCLK_X and MCLK_R must be 2.048 MHz for the ETC5057, or 1.536 MHz, 1.544 MHz for the ETC5054, and need not be synchronous. For best transmission performance, however, MCLK_R should be synchronous with MCLK_X, which is easily achieved by applying only static logic levels to the MCLK_R/PDN pin. This will automatically connect MCLK_X to all internal MCLK_R functions (see pin description). For 1.544 MHz operation, the device automatically compensates for the 193rd clock pulse each frame. FS_X starts each encoding cycle and must be synchronous with MCLK_X and BCLK_X. FS_R starts each decoding cycle and must be synchronous with BCLK_R. BCLK_R must be a clock, the logic levels shown in table 1 are not valid in asynchronous mode. BCLK_X and BCLK_R may operate from 64 kHz to 2.048 MHz.

SHORT FRAME SYNC OPERATION

The device can utilize either a short frame sync pulse or a long frame sync pulse. Upon power initialization, the device assumes a short frame mode. In this mode, both frame sync pulses, FS_X and FS_R, must be one bit clock period long, with timing relationships specified in figure 2. With FS_X high during a falling edge of BCLK_X the next rising edge of BCLK_X enables the D_X TRI-STATE output buffer, which will output the sign bit. The following seven rising edges clock out the remaining seven bits, and the next falling edge disables the D_X output. With FS_R high during a falling edge of BCLK_R (BCLK_X in synchronous mode), the next falling edge of BCLK_R latches in the sign bit. The following seven falling edges latch in the seven remaining bits. Both devices may utilize the short frame sync pulse in synchronous or asynchronous operating mode.

LONG FRAME SYNC OPERATION

To use the long frame mode, both the frame sync pulses, FS_X and FS_R, must be three or more bit clock periods long, with timing relationships specified in figure 3. Based on the transmit frame sync, FS_X, the device will sense whether short or long frame sync pulses are being used. For 64 kHz operation, the frame sync pulse must be kept low for a minimum of 160 ns (see fig. 1). The D_X TRI-STATE output buffer is enabled with the rising edge of FS_X or the rising edge of BCLK_X, whichever comes later, and the first bit clocked out is the sign bit. The following seven BCLK_X rising

Table 1: Selection of Master Clock Frequencies.

BCLK _R /CLKSEL	Master Clock Frequency Selected	
	ETC5057	ETC5054
Clocked	2.048 MHz	1.536 MHz or 1.544 MHz
0	1.536 MHz or 1.544 MHz	2.048 MHz
1 (or open circuit)	2.048 MHz	1.536 MHz or 1.544 MHz



edges clock out the remaining seven bits. The D_X output is disabled by the falling $BCLK_X$ edge following the eighth rising edge, or by FS_X going low, whichever comes later. A rising edge on the receive frame sync pulse, FS_R , will cause the PCM data at D_R to be latched in on the next eight falling edges of $BCLK_R$ ($BCLK_X$ in synchronous mode). Both devices may utilize the long frame sync pulse in synchronous or asynchronous mode.

TRANSMIT SECTION

The transmit section input is an operational amplifier with provision for gain adjustment using two external resistors, see figure 6. The low noise and wide bandwidth allow gains in excess of 20 dB across the audio passband to be realized. The op amp drives a unitygain filter consisting of R_D active pre-filter, followed by an eighth order switched-capacitor bandpass filter clocked at 256 kHz. The output of this filter directly drives the encoder sample-and-hold circuit. The A/D is of companding type according to A-law (ETC5057) or μ -law (ETC5054) coding conventions. A precision voltage reference is trimmed in manufacturing to provide an input overload (t_{MAX}) of nominally 2.5V peak (see table of transmission characteristics). The FS_X frame sync pulse controls the sampling of the filter output, and then the successive-ap-

proximation encoding cycle begins. The 8-bit code is then loaded into a buffer and shifted out through D_X at the next FS_X pulse. The total encoding delay will be approximately 165 μ s (due to the transmit filter) plus 125 μ s (due to encoding delay), which totals 290 μ s. Any offset voltage due to the filters or comparator is cancelled by sign bit integration.

RECEIVE SECTION

The receive section consists of an expanding DAC which drives a fifth order switched-capacitor low pass filter clocked at 256 kHz. The decoder is A-law (ETC5057) or μ -law (ETC5054) and the 5th order low pass filter corrects for the $\sin x/x$ attenuation due to the 8 kHz sample and hold. The filter is then followed by a 2nd order RC active post-filter and power amplifier capable of driving a 600 Ω load to a level of 7.2 dBm. The receive section is unity-gain. Upon the occurrence of FS_R , the data at the D_R input is clocked in on the falling edge of the next eight $BCLK_R$ ($BCLK_X$) periods. At the end of the decoder time slot, the decoding cycle begins, and 10 μ s later the decoder DAC output is updated. The total decoder delay is \sim 10 μ s (decoder update) plus 110 μ s (filter delay) plus 62.5 μ s (1/2 frame), which gives approximately 180 μ s. A mute circuitry is active during 10ms when power up.

ABSOLUTE MAXIMUM RATINGS

Symbol	Parameter	Value	Unit
V_{CC}	V_{CC} to GNDA	7	V
V_{BB}	V_{BB} to GNDA	-7	V
V_{IN}, V_{OUT}	Voltage at any Analog Input or Output	$V_{CC} + 0.3$ to $V_{BB} - 0.3$	V
	Voltage at Any Digital Input or Output	$V_{CC} + 0.3$ to $GNDA - 0.3$	V
T_{oper}	Operating Temperature Range	-25 to +125	$^{\circ}C$
T_{stg}	Storage Temperature Range	-65 to +150	$^{\circ}C$
	Lead Temperature (soldering, 10 seconds)	300	$^{\circ}C$

ELECTRICAL OPERATING CHARACTERISTICS $V_{CC} = 5.0 V \pm 5\%$, $V_{BB} = -5.0 V \pm 5\%$, $GNDA = 0 V$, $T_A = 0^{\circ}C$ to $70^{\circ}C$; Typical Characteristics Specified at $V_{CC} = 5.0 V$, $V_{BB} = -5.0 V$, $T_A = 25^{\circ}C$; all signals are referenced to GNDA.

Symbol	Parameter	Min.	Typ.	Max.	Unit
V_{IL}	Input Low Voltage			0.6	V
V_{IH}	Input High Voltage	2.2			V
V_{OL}	Output Low Voltage $I_L = 3.2mA$			0.4	V
	$I_L = 3.2mA$, Open Drain $\frac{D_X}{TS_X}$			0.4	V
V_{OH}	Output High Voltage $I_H = 3.2mA$	D_X	2.4		V
I_{IL}	Input Low Current ($GNDA \leq V_{IN} \leq V_{IL}$, all digital inputs)	-10		10	μA
I_{IH}	Input High Current ($V_{IH} \leq V_{IN} \leq V_{CC}$) except $BCLK_R/BCLKSEL$	-10		10	μA
I_{OZ}	Output Current in HIGH Impedance State (TRI-STATE) ($GNDA \leq V_O \leq V_{CC}$)	D_X	-10	10	μA

ETC5054 - ETC5057

ANALOG INTERFACE WITH TRANSMIT INPUT AMPLIFIER (all devices)

Symbol	Parameter	Min.	Typ.	Max.	Unit
I _I XA	Input Leakage Current (-2.5V ≤ V ≤ +2.5V) VF _{XI} ⁺ or VF _{XI} ⁻	- 200		200	nA
R _I XA	Input Resistance (-2.5V ≤ V ≤ +2.5V) VF _{XI} ⁺ or VF _{XI} ⁻	10			MΩ
R _O XA	Output Resistance (closed loop, unity gain)		1	3	Ω
R _L XA	Load Resistance GS _X	10			kΩ
C _L XA	Load Capacitance GS _X			50	pF
V _O XA	Output Dynamic Range (R _L ≥ 10KΩ) GS _X	±2.8			V
AV _X A	Voltage Gain (VF _{XI} ⁺ to GS _X)	5000			V/V
F _U XA	Unity Gain Bandwidth	1	2		MHz
V _{OS} XA	Offset Voltage	- 20		20	mV
V _{CM} XA	Common-mode Voltage	- 2.5		2.5	V
CMRR _{XA}	Common-mode Rejection Ratio	60			dB
PSRR _{XA}	Power Supply Rejection Ratio	60			dB

ANALOG INTERFACE WITH RECEIVE FILTER (all devices)

Symbol	Parameter	Min.	Typ.	Max.	Unit
R _O RF	Output Resistance VF _{RO}		1	3	Ω
R _L RF	Load Resistance (VF _{RO} = ±2.5V)	600			Ω
C _L RF	Load Capacitance			500	pF
V _{OS} RO	Output DC Offset Voltage	- 200		200	mV

POWER DISSIPATION (all devices)

Symbol	Parameter	Min.	Typ.	Max.	Unit
I _{CC0}	Power-down Current		0.5	1.5	mA
I _{BB0}	Power-down Current		0.05	0.3	mA
I _{CC1}	Active Current		6.0	9.0	mA
I _{BB1}	Active Current		6.0	9.0	mA

TIMING SPECIFICATIONS

Symbol	Parameter	Min.	Typ.	Max.	Unit
$1/t_{PM}$	Frequency of master clocks Depends on the device used and the BCLK _R /CLKSEL Pin MCLK _X and MCLK _R		1.536 1.544 2.048		MHz MHz MHz
t_{WMH}	Width of Master Clock High MCLK _X and MCLK _R	160			ns
t_{WML}	Width of Master Clock Low MCLK _X and MCLK _R	160			ns
t_{RM}	Rise Time of Master Clock MCLK _X and MCLK _R			50	ns
t_{FM}	Fall Time of Master Clock MCLK _X and MCLK _R			50	ns
t_{PB}	Period of Bit Clock	485	488	15.725	ns
t_{WBH}	Width of Bit Clock High ($V_{IH} = 2.2V$)	160			ns
t_{WBL}	Width of Bit Clock Low ($V_{IL} = 0.6V$)	160			ns
t_{RB}	Rise Time of Bit Clock ($t_{PB} = 488ns$)			50	ns
t_{FB}	Fall Time of Bit Clock ($t_{PB} = 488ns$)			50	ns
t_{SBFM}	Set-up time from BCLK _X high to MCLK _X falling edge. (first bit clock after the leading edge of FS _X)	100			ns
t_{HBF}	Holding Time from Bit Clock Low to the Frame Sync (long frame only)	0			ns
t_{SFB}	Set-up Time from Frame Sync to Bit Clock (long frame only)	80			ns
t_{HBF1}	Hold Time from 3rd Period of Bit Clock Low to Frame Sync (long frame only)	100			ns
t_{DZF}	Delay time to valid data from FS _X or BCLK _X , whichever comes later and delay time from FS _X to data output disabled. ($C_L = 0pF$ to $150pF$)	20		165	ns
t_{DBD}	Delay time from BCLK _X high to data valid. (load = $150pF$ plus 2 LSTTL loads)	0		180	ns
t_{DZC}	Delay time from BCLK _X low to data output disabled.	50		165	ns
t_{SDB}	Set-up time from D _R valid to BCLK _{R/X} low.	50			ns
t_{HBD}	Hold time from BCLK _{R/X} low to D _R invalid.	50			ns
t_{HOLD}	Holding Time from Bit Clock High to Frame Sync (short frame only)	0			ns
t_{SF}	Set-up Time from FS _{X/R} to BCLK _{X/R} Low (short frame sync pulse) - Note 1	80			ns
t_{HF}	Hold Time from BCLK _{X/R} Low to FS _{X/R} Low (short frame sync pulse) - Note 1	100			ns
t_{XDp}	Delay Time to TS _X low (load = $150pF$ plus 2 LSTTL loads)			140	ns
t_{WFL}	Minimum Width of the Frame Sync Pulse (low level) 64kbit/s operating mode)	160			ns

Note 1: For short frame sync timing FS_X and FS_R must go high while their respective bit clocks are high.

Figure 1: 64kbits/s TIMING DIAGRAM (see next page for complete timing).

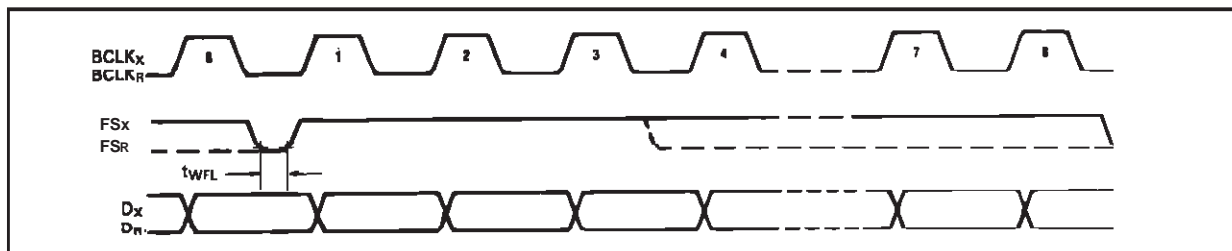
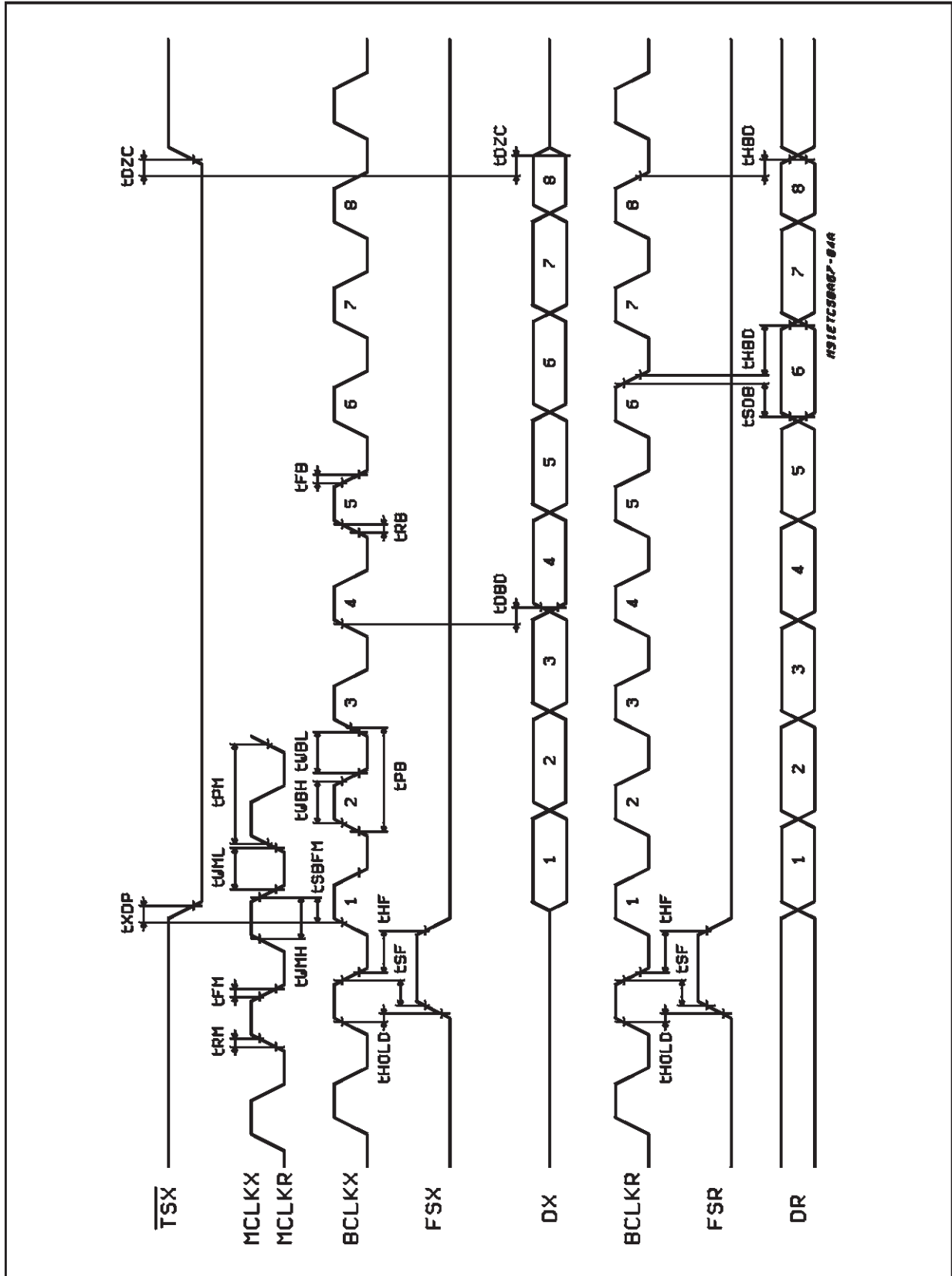


Figure 2: Short Frame Sync Timing



TRANSMISSION CHARACTERISTICS

$T_A = 0$ to 70°C , $V_{CC} = +5\text{V} \pm 5\%$, $V_{BB} = -5\text{V} \pm 5\%$, $G_{NDA} = 0\text{V}$, $f = 1.0\text{KHz}$, $V_{IN} = 0\text{dBm0}$ transmit input amplifier connected for unity-gain non-inverting (unless otherwise specified).

AMPLITUDE RESPONSE

Symbol	Parameter	Min.	Typ.	Max.	Unit
	Absolute levels - nominal 0 dBm0 level is 4 dBm (600 Ω) 0 dBm0		1.2276		Vrms
t_{MAX}	Max Overload Level 3.14 dBm0 (A LAW) 3.17 dBm0 (U LAW)		2.492 2.501		V_{PK} V_{PK}
G_{XA}	Transmit Gain, Absolute ($T_A = 25^\circ\text{C}$, $V_{CC} = 5\text{V}$, $V_{BB} = -5\text{V}$) Input at $GS_X = 0\text{ dBm0}$ at 1020 Hz	- 0.15		0.15	dB
G_{XR}	Transmit Gain, Relative to G_{XA} f = 16 Hz f = 50 Hz f = 60 Hz f = 180 Hz f = 200 Hz f = 300 Hz - 3000 Hz f = 3300 Hz f = 3400 Hz f = 4000 Hz f = 4600 Hz and up, Measure Response from 0 Hz to 4000 Hz	- 2.8 - 1.8 - 0.15 - 0.35 - 0.7		- 40 - 30 - 26 - 0.2 - 0.1 0.15 0.05 0 - 14 - 32	dB
G_{XAT}	Absolute Transmit Gain Variation with Temperature $T_A = 0$ to $+70^\circ\text{C}$	- 0.1		0.1	dB
G_{XAV}	Absolute Transmit Gain Variation with Supply Voltage ($V_{CC} = 5\text{V} \pm 5\%$, $V_{BB} = -5\text{V} \pm 5\%$)	- 0.05		0.05	dB
G_{XRL}	Transmit Gain Variations with Level Sinusoidal Test Method Reference Level = - 10 dBm0 $V_{FXI+} = -40\text{ dBm0}$ to $+3\text{ dBm0}$ $V_{FXI-} = -50\text{ dBm0}$ to -40 dBm0 $V_{FXI+} = -55\text{ dBm0}$ to -50 dBm0	- 0.2 - 0.4 - 1.2		0.2 0.4 1.2	dB dB dB
G_{RA}	Receive Gain, Absolute ($T_A = 25^\circ\text{C}$, $V_{CC} = 5\text{V}$, $V_{BB} = -5\text{V}$) Input = Digital Code Sequence for 0dBm0 Signal at 1020Hz	- 0.15		0.15	dB
G_{RR}	Receive Gain, Relative to G_{RA} f = 0Hz to 3000Hz f = 3300Hz f = 3400Hz f = 4000Hz	- 0.35 - 0.35 - 0.7		0.20 0.05 0 - 14	dB dB dB dB
G_{RAT}	Absolute Transmit Gain Variation with Temperature $T_A = 0$ to $+70^\circ\text{C}$	- 0.1		0.1	dB
G_{RAV}	Absolute Receive Gain Variation with Supply Voltage ($V_{CC} = 5\text{V} \pm 5\%$, $V_{BB} = -5\text{V} \pm 5\%$)	- 0.05		0.05	dB
G_{RRL}	Receive Gain Variations with Level Sinusoidal Test Method; Reference input PCM code corresponds to an ideally encoded - 10 dBm0 signal PCM level = - 40 dBm0 to $+3\text{ dBm0}$ PCM level = - 50 dBm0 to -40 dBm0 PCM level = - 55 dBm0 to -50 dBm0	- 0.2 - 0.4 - 1.2		0.2 0.4 1.2	dB dB dB
V_{RO}	Receive Output Drive Level ($R_L = 600\Omega$)	- 2.5		2.5	V

TRANSMISSION (continued)

ENVELOPE DELAY DISTORTION WITH FREQUENCY

Symbol	Parameter	Min.	Typ.	Max.	Unit
D _{XA}	Transmit Delay, Absolute (f = 1600Hz)		290	315	μs
D _{XR}	Transmit Delay, Relative to D _{XA} f = 500Hz - 600Hz f = 600Hz - 800Hz f = 800Hz - 1000Hz f = 1000Hz - 1600Hz f = 1600Hz - 2600Hz f = 2600Hz - 2800Hz f = 2800Hz - 3000Hz		195 120 50 20 55 80 130	220 145 75 40 75 105 155	μs
D _{RA}	Receive Delay, Absolute (f = 1600Hz)		180	200	μs
D _{RR}	Receive Delay, Relative to D _{RA} f = 500Hz - 1000Hz f = 1000Hz - 1600Hz f = 1600Hz - 2600Hz f = 2600Hz - 2800Hz f = 2800Hz - 3000Hz	- 40 - 30	- 25 - 20 70 100 145	90 125 175	μs

NOISE

Symbol	Parameter	Min.	Typ.	Max.	Unit
N _{XP}	Transmit Noise, P Message Weighted (A LAW, VFXI ⁺ = 0 V) 1)		- 74	- 69	dBm0p
N _{RP}	Receive Noise, P Message Weighted (A LAW, PCM code equals positive zero)		- 82	- 79	dBm0p
N _{XC}	Transmit Noise, C Message Weighted μ LAW (VFXI ⁺ = 0 V)		12	15	dBmC0
N _{RC}	Receive Noise, C Message Weighted (μ LAW, PCM Code Equals Alternating Positive and Negative Zero)		8	11	dBmC0
N _{RS}	Noise, Single Frequency f = 0 kHz to 100 kHz, Loop around Measurement, VFXI ⁺ = 0 Vrms			- 53	dBm0
PPSR _X	Positive Power Supply Rejection, Transmit (note 2) V _{CC} = 5.0 V _{DC} + 100 mVrms, f = 0 kHz-50 kHz	40			dBp
NPSR _X	Negative Power Supply Rejection, Transmit (note 2) V _{BB} = - 5.0 V _{DC} + 100 mVrms, f = 0 kHz-50 kHz	40			dBp
PPSR _R	Positive Power Supply Rejection, Receive (PCM code equals positive zero, V _{CC} = 5.0 V _{DC} + 100mVrms) f = 0Hz to 4000Hz f = 4KHz to 25KHz f = 25KHz to 50KHz	40 40 36			dBp dB dB
NPSR _R	Negative Power Supply Rejection, Receive (PCM code equals positive zero, V _{BB} = 5.0 V _{DC} + 100mVrms) f = 0Hz to 4000Hz f = 4KHz to 25KHz f = 25KHz to 50KHz	40 40 36			dBp dB dB

ETC5054 - ETC5057

TRANSMISSION CHARACTERISTICS (continued)

NOISE (continued)

Symbol	Parameter	Min.	Typ.	Max.	Unit
SOS	Spurious out-of-band Signals at the Channel Output				
	Loop around measurement, 0dBm0, 300Hz - 3400Hz input applied to DR, measure individual image signals at DX				
	4600Hz - 7600Hz			- 32	dB
	7600Hz - 8400Hz			- 40	dB
	8400Hz - 100,000Hz			- 32	dB

DISTORTION

Symbol	Parameter	Min.	Typ.	Max.	Unit
STD _X or STD _R	Signal to Total Distortion (sinusoidal test method)				
	Transmit or Receive Half-channel				
	Level = 3.0dBm0	33			
	Level = 0dBm0 to -30dBm0	36			
	Level = -40dBm0	29			
	XMT				
	RCV				
	Level = -55dBm0	14			
	XMT				
	RCV	15			
SFD _X	Single Frequency Distortion, Transmit (T _A = 25°C)			-46	dB
SFD _R	Single Frequency Distortion, Receive (T _A = 25°C)			-46	dB
IMD	Intermodulation Distortion Loop Around Measurement, VFXI+ = -4dBm0 to -21dBm0, two Frequencies in the Range 300Hz - 3400Hz			-41	dB

CROSSTALK

Symbol	Parameter	Min.	Typ.	Max.	Unit
CT _{X-R}	Transmit to Receive Crosstalk, 0 dBm0 Transmit Level f = 300Hz to 3400Hz, D _R = Steady PCM Mode		- 90	- 75	dB
CT _{R-X}	Receive to Transmit Crosstalk, 0 dBm0 Receive Level f = 300Hz to 3400Hz, (note 2)		- 90	- 70	dB

Notes:

- 1) Measured by extrapolation from distortion test results.
- 2) PPSR_X, NPSR_X, CT_{R-X} is measured with a -50dBm0 activating signal applied at VFXI⁺.

ENCODING FORMAT AT D_X OUTPUT

	A-Law (including even bit inversion)	μLaw
V _{IN} (at GS _X) = +Full-scale	1 0 1 0 1 0 1 0	1 0 0 0 0 0 0 0
V _{IN} (at GS _X) = 0V	1 1 0 1 0 1 0 1 0 1 0 1 0 1 0 1	1 1 1 1 1 1 1 1 0 1 1 1 1 1 1 1
V _{IN} (at GS _X) = - Full-scale	0 0 1 0 1 0 1 0	0 0 0 0 0 0 0 0

APPLICATION INFORMATION

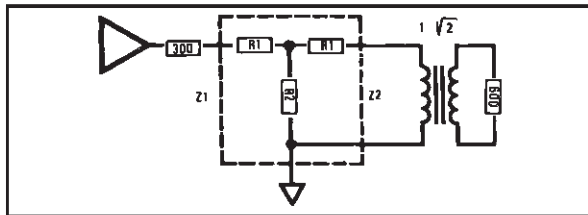
POWER SUPPLIES

While the pins at the ETC505X family are well protected against electrical misuse, it is recommended that the standard CMOS practice be followed, ensuring that ground is connected to the device before any-other connections are made. In applications where the printed circuit board may be plugged into a "hot" socket with power and clocks already present, an extra long ground pin in the connector should be used.

All ground connections to each device should meet at a common point as close as possible to the GNDA pin. This minimizes the interaction of ground return currents flowing through a common bus impedance. 0.1µF supply decoupling capacitors should be connected from this common ground point to V_{CC} and V_{BB} as close to the device as possible.

For best performance, the ground point of each CODEC/FILTER on a card should be connected to a common card ground in star formation, rather than via a ground bus. This common ground point should be decoupled to V_{CC} and V_{BB} with 10µF capacitors.

Figure 4: T-PAD Attenuator



$$R1 = Z1 \left(\frac{N^2 + 1}{N^2 - 1} \right) - 2 \sqrt{Z1 \cdot Z2} \left(\frac{N}{N^2 - 1} \right)$$

$$R2 = 2 \sqrt{Z1 \cdot Z2} \left(\frac{N}{N^2 - 1} \right)$$

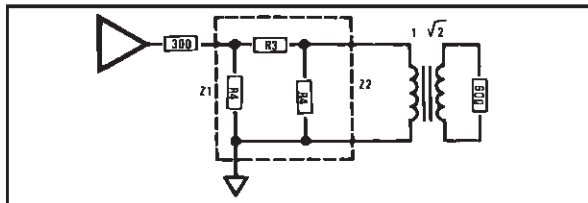
Where: $N = \sqrt{\frac{\text{POWERIN}}{\text{POWEROUT}}}$

and: $S = \sqrt{\frac{Z1}{Z2}}$

Also : $Z = \sqrt{Z_{SC} \cdot Z_{OC}}$

Where Z_{SC} = impedance with short circuit termination and Z_{OC} = impedance with open circuit termination.

Figure 5: Π-PAD Attenuator



$$R3 = \sqrt{\frac{Z1 \cdot Z2}{2}} \left(\frac{N^2 - 1}{N} \right)$$

$$R3 = Z1 \left(\frac{N^2 - 1}{N^2 - 2NS + 1} \right)$$

RECEIVE GAIN ADJUSTMENT

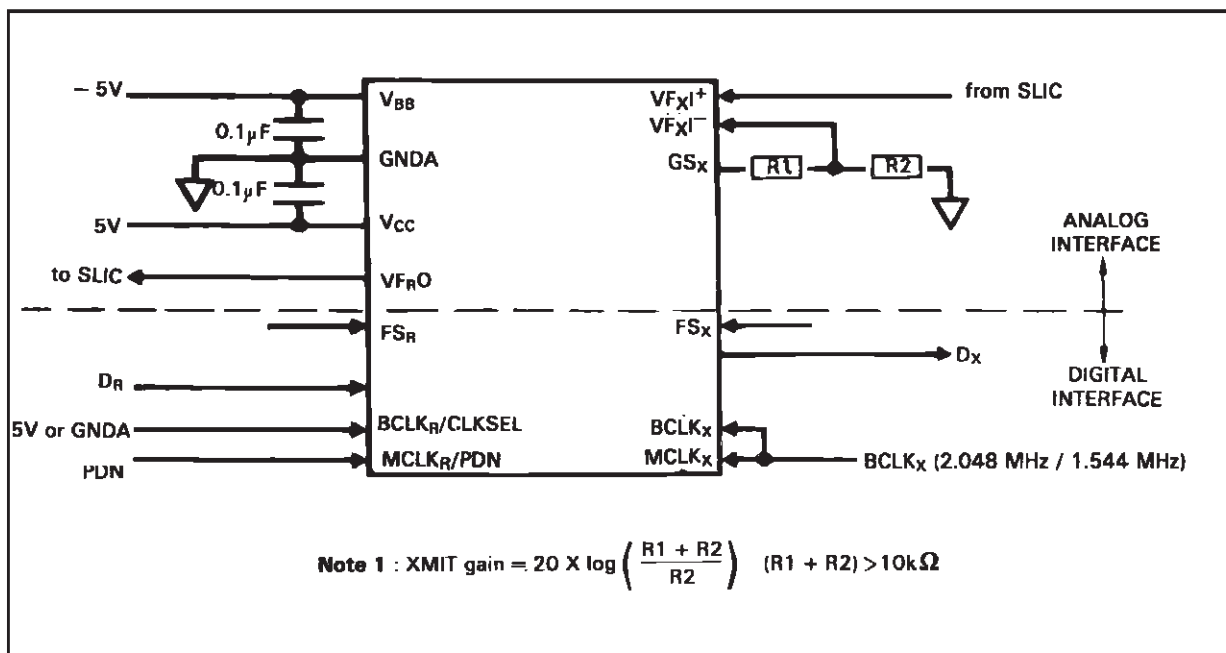
For applications where a ETC505X family CODEC/filter receive output must drive a 600Ω load, but a peak swing lower than ± 2.5V is required, the receive gain can be easily adjusted by inserting a matched T-pad or π -pad at the output. Table II lists the required resistor values for 600Ω terminations. As these are generally non-standard values, the equations can be used to compute the attenuation of the closest practical set of resistors. It may be necessary to use unequal values for the R1 or R4 arms of the attenuators to achieve a precise attenuation. Generally it is tolerable to allow a small deviation of the input impedance from nominal while still maintaining a good return loss. For example a 30dB return loss against 600Ω is obtained if the output impedance of the attenuator is in the range 282Ω to 319Ω (assuming a perfect transformer).

Table 2 : Attenuator Tables For Z1 = Z2 = 300 Ω (all values in Ω).

dB	R1	R2	R3	R4
0.1	1.7	26k	3.5	52k
0.2	3.5	13k	6.9	26k
0.3	5.2	8.7k	10.4	17.4k
0.4	6.9	6.5k	13.8	13k
0.5	8.5	5.2k	17.3	10.5k
0.6	10.4	4.4k	21.3	8.7k
0.7	12.1	3.7k	24.2	7.5k
0.8	13.8	3.3k	27.7	6.5k
0.9	15.5	2.9k	31.1	5.8k
1.0	17.3	2.6k	34.6	5.2k
2	34.4	1.3k	70	2.6k
3	51.3	850	107	1.8k
4	68	650	144	1.3k
5	84	494	183	1.1k
6	100	402	224	900
7	115	380	269	785
8	129	284	317	698
9	143	244	370	630
10	156	211	427	527
11	168	184	490	535
12	180	161	550	500
13	190	142	635	473
14	200	125	720	450
15	210	110	816	430
16	218	98	924	413
18	233	77	1.17k	386
20	246	61	1.5k	366

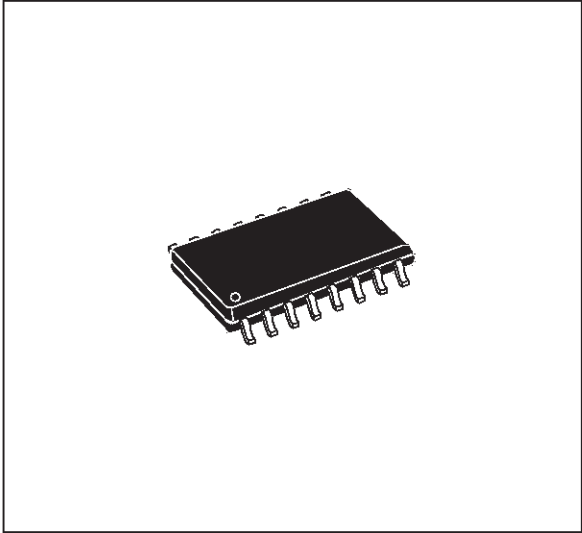


Figure 6: Typical Synchronous Application.

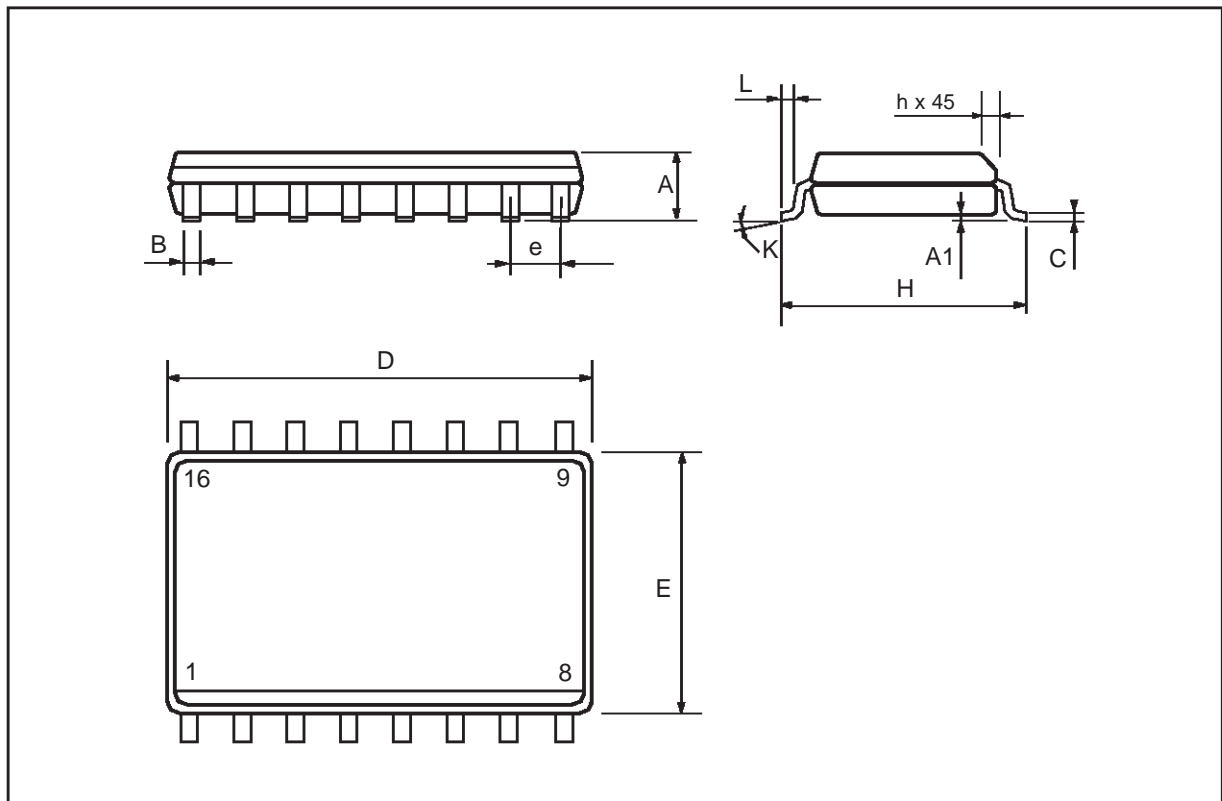


DIM.	mm			inch		
	MIN.	TYP.	MAX.	MIN.	TYP.	MAX.
A	2.35		2.65	0.093		0.104
A1	0.1		0.3	0.004		0.012
B	0.33		0.51	0.013		0.020
C	0.23		0.32	0.009		0.013
D	10.1		10.5	0.398		0.413
E	7.4		7.6	0.291		0.299
e		1.27			0.050	
H	10		10.65	0.394		0.419
h	0.25		0.75	0.010		0.030
L	0.4		1.27	0.016		0.050
K	0° (min.)8° (max.)					

OUTLINE AND MECHANICAL DATA

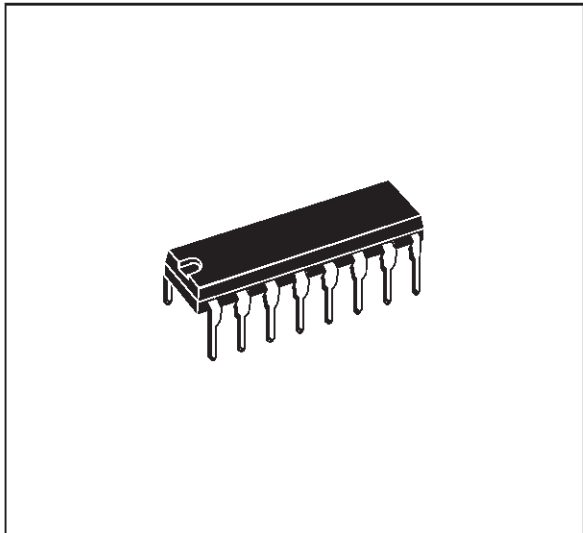


SO16 Wide

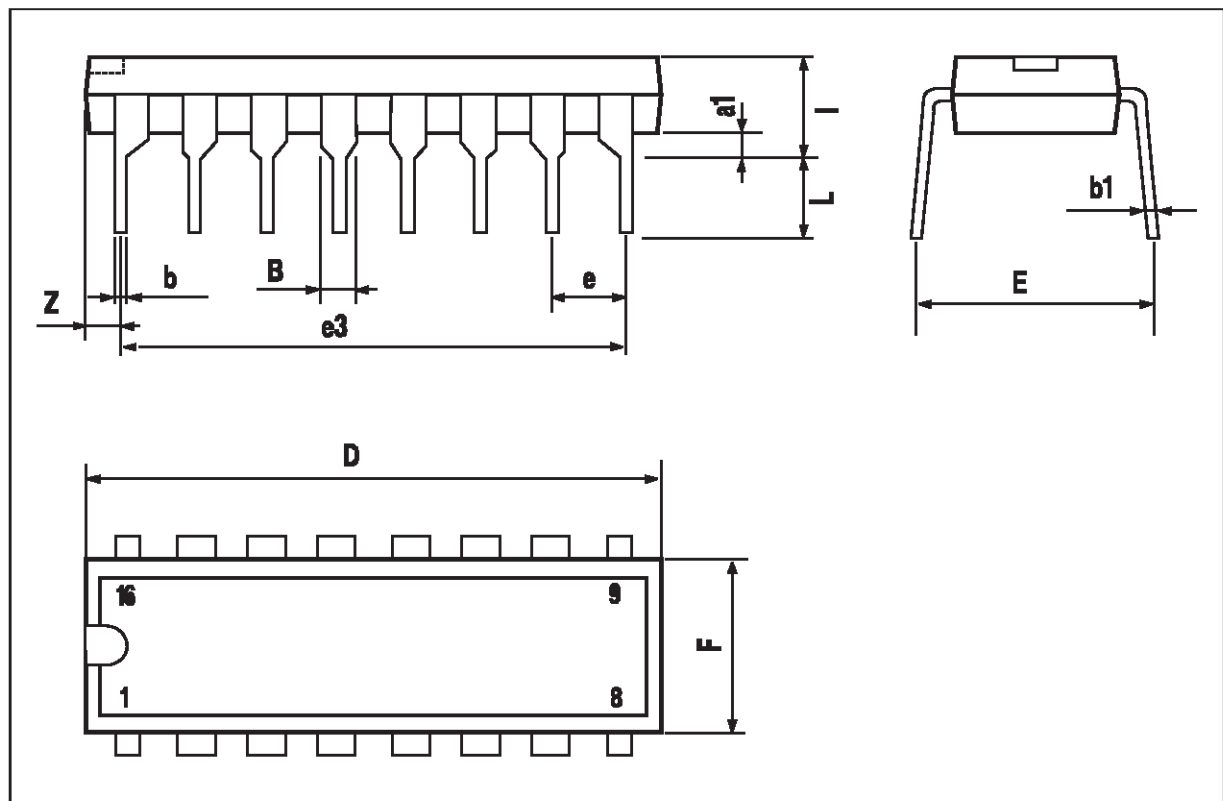


DIM.	mm			inch		
	MIN.	TYP.	MAX.	MIN.	TYP.	MAX.
a1	0.51			0.020		
B	0.77		1.65	0.030		0.065
b		0.5			0.020	
b1		0.25			0.010	
D			20			0.787
E		8.5			0.335	
e		2.54			0.100	
e3		17.78			0.700	
F			7.1			0.280
I			5.1			0.201
L		3.3			0.130	
Z			1.27			0.050

OUTLINE AND MECHANICAL DATA

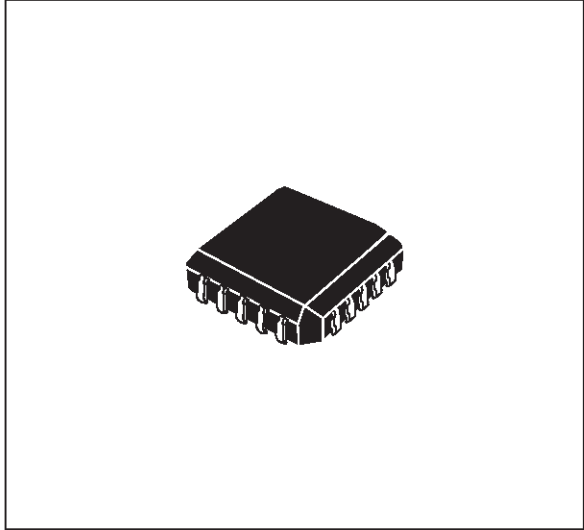


DIP16

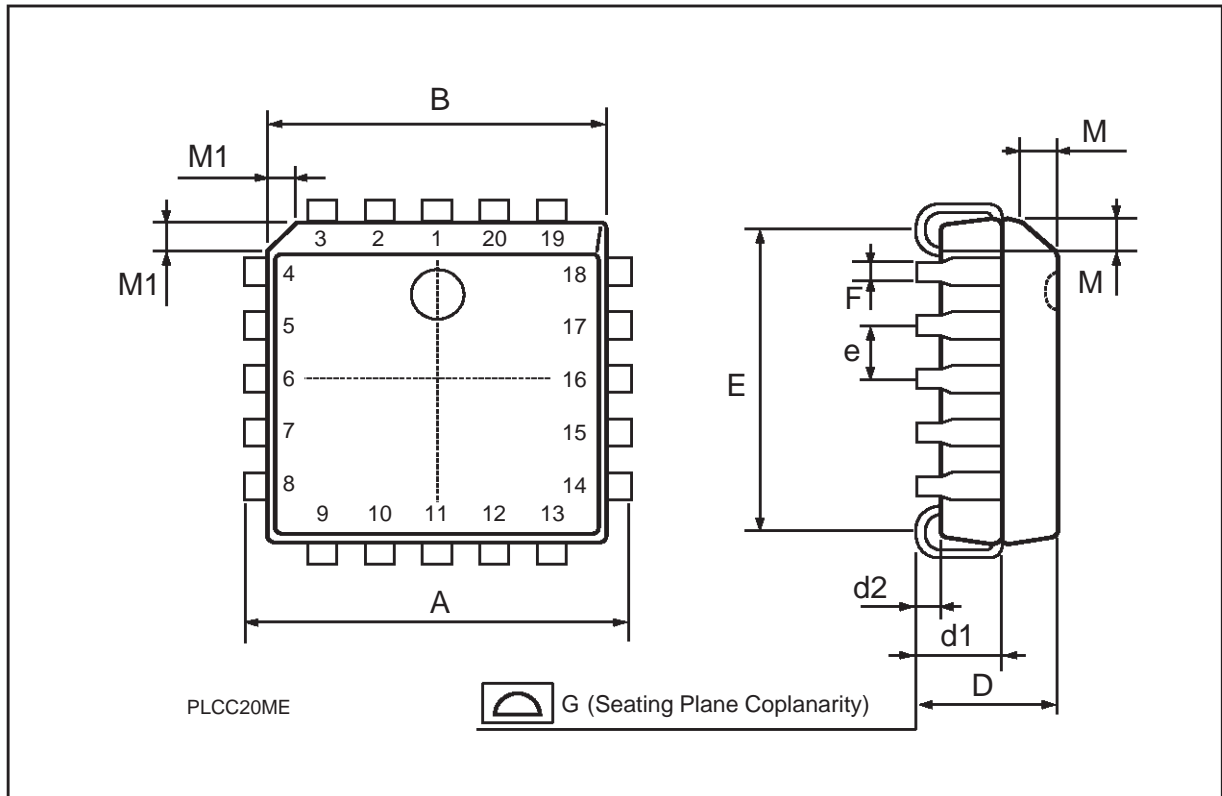


DIM.	mm			inch		
	MIN.	TYP.	MAX.	MIN.	TYP.	MAX.
A	9.78		10.03	0.385		0.395
B	8.89		9.04	0.350		0.356
D	4.2		4.57	0.165		0.180
d1		2.54			0.100	
d2		0.56			0.022	
E	7.37		8.38	0.290		0.330
e		1.27			0.050	
F		0.38			0.015	
G			0.101			0.004
M		1.27			0.050	
M1		1.14			0.045	

OUTLINE AND MECHANICAL DATA



PLCC20



Information furnished is believed to be accurate and reliable. However, STMicroelectronics assumes no responsibility for the consequences of use of such information nor for any infringement of patents or other rights of third parties which may result from its use. No license is granted by implication or otherwise under any patent or patent rights of STMicroelectronics. Specification mentioned in this publication are subject to change without notice. This publication supersedes and replaces all information previously supplied. STMicroelectronics products are not authorized for use as critical components in life support devices or systems without express written approval of STMicroelectronics.

The ST logo is a registered trademark of STMicroelectronics

© 2000 STMicroelectronics – Printed in Italy – All Rights Reserved

STMicroelectronics GROUP OF COMPANIES

Australia - Brazil - China - Finland - France - Germany - Hong Kong - India - Italy - Japan - Malaysia - Malta - Morocco -
Singapore - Spain - Sweden - Switzerland - United Kingdom - U.S.A.

<http://www.st.com>



LittleDiode supplies new, hard to find or obsolete electronic components and semiconductors all over the world.

With over two million different components listed you are sure to find the part you need.

Feel free to visit us today at our online store:

LittleDiode.com

Looking forward to providing you with the best possible service.