

DEFLECTION PROCESSOR FOR CRT DISPLAY

The KA2138 is a monolithic integrated circuit encapsulated in a 20 dual-in-line package designed for vertical, horizontal deflection signal processing for a CRT display.

This IC can be connected to the KA2131 (for vertical output use) to form a deflection processing that uses every requirement for a CRT display.

FUNCTIONS

[Vertical Block]

- Vertical oscillator & Ramp generator
- Sampling type DC voltage control within retrace time

[Horizontal Block]

- Horizontal oscillator & AFC
- X-ray protector
- AFC sawtooth wave generator
- Horizontal pulse duty setting
- Horizontal phase shifter

FEATURES

- Vertical pull-in range 20Hz permits non-adjusting at vertical synchronizing 50Hz or 60Hz.
- Good vertical linearity because DC supplying at the vertical output stage is subjected to sampling type control during retrace time
- The horizontal oscillation frequency is stable from 15KHz to 100KHz.
- The horizontal display can be shifted right or left
- The horizontal/vertical synchronizing pulse input can be used intact regardless of the difference in pulse polarity and pulse width.
- The AFC feedback sawtooth wave can be obtained by simply applying a flyback pulse to the IC as a trigger pulse
- Any duty of horizontal pulse can be set

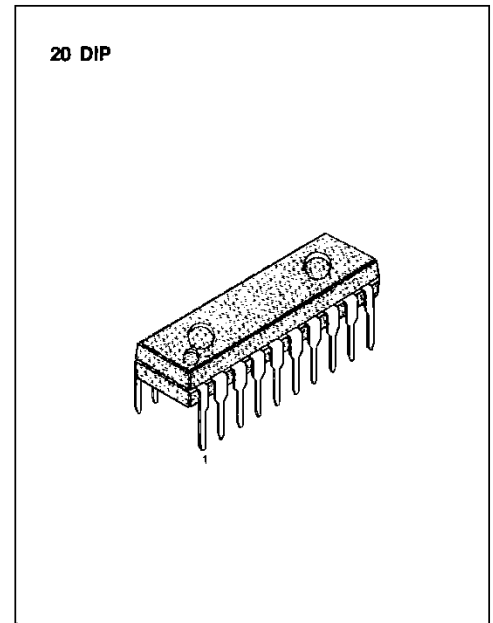

ORDERING INFORMATION

Device	Package	Operating Temperature
KA2138N	20 DPI	-20 ~ +70°C

BLOCK DIAGRAM

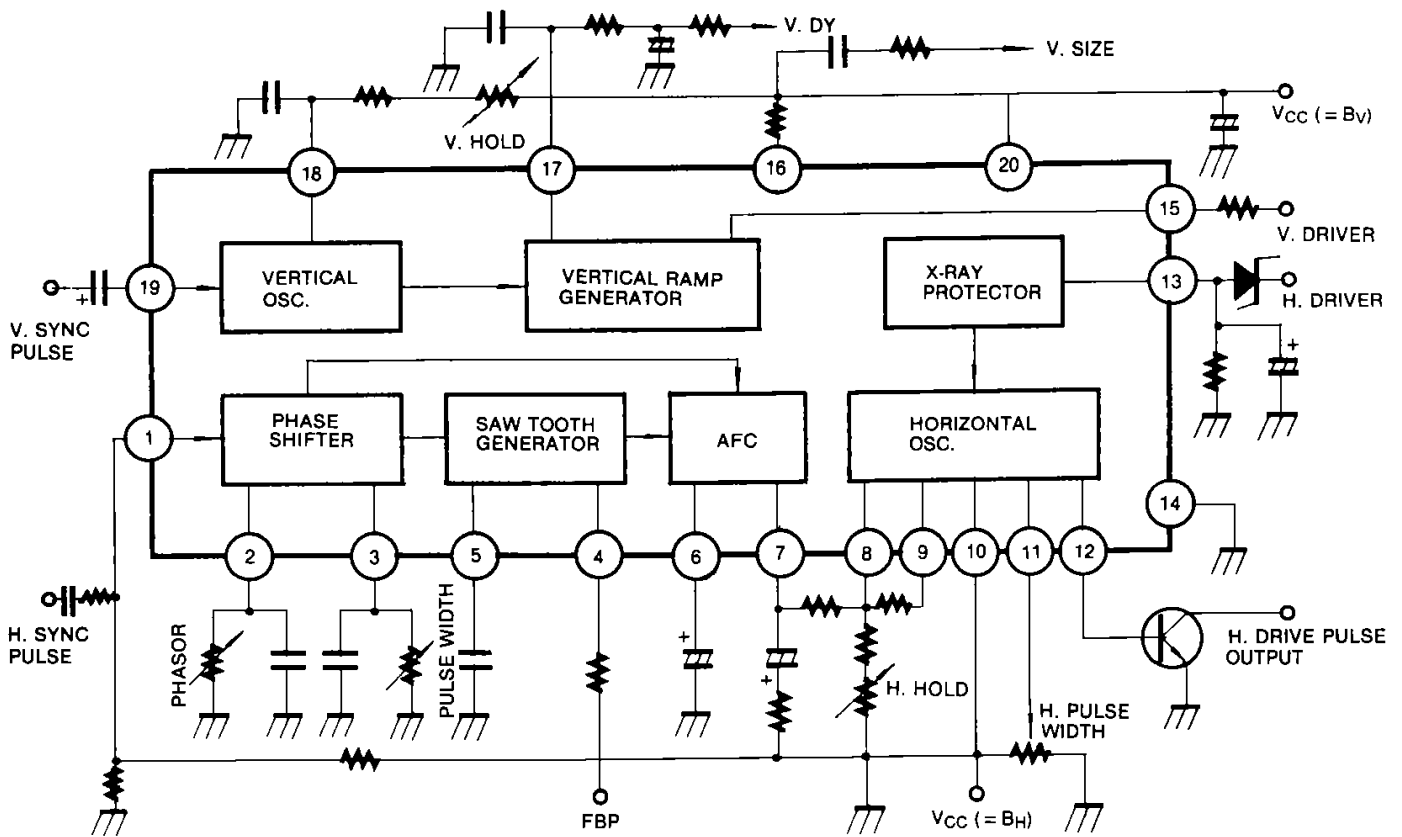

Fig. 1

ABSOLUTE MAXIMUM RATINGS ($T_a = 25^\circ\text{C}$)

Characteristic	Symbol	Value	Unit
Supply Voltage	$V_{10(\max)}, V_{20(\max)}$	14	V
Power Dissipation	P_D	780	mW
Operating Temperature	T_{OPR}	-20 ~ +70	$^\circ\text{C}$
Storage Temperature	T_{STG}	-55 ~ +150	$^\circ\text{C}$

RECOMMENDED OPERATING CONDITIONS ($T_a = 25^\circ\text{C}$)

Characteristic	Symbol	Min	Typ	Max	Unit
Supply Voltage	V_{10}, V_{20}	9	12	13.5	V
Vert. Pulse Voltage	V_V	2.0	5.0	6.0	V_{pp}
Horiz. Pulse Voltage	V_H	2.0	5.0	6.0	V_{pp}

ELECTRICAL CHARACTERISTICS ($V_{CC10} = V_{CC20} = 12V$, $T_a = 25^\circ C$)

Characteristic	Symbol	Test Conditions	Min	Typ	Max	Unit
Quiescent Current	I_{10}	$V_{CC10} = 12V$	12		30	mA
	I_{20}	$V_{CC20} = 12V$	5		12	mA

Vertical Part

Pull-In Range	$f_{V(PULL)}$	Synchronizing pulse frequency 60Hz	21	23		Hz
Free-Running Frequency	f_V		55	60	65	Hz
Frequency Drift with Supply Voltage	$\Delta f_V/V_{CC}$	$V_{20} = 12 \pm 1V$, 60Hz at 12V	-0.1		0.1	Hz
Center Voltage Control Threshold Level			3.8		4.4	V
Frequency Drift with Ambient Temperature	$\Delta f_{(V)}$	$T_a = -10$ to $+60^\circ C$	-0.028		0.028	Hz/ $^\circ C$
Oscillation Start Voltage	$V_{OSC(V)}$				4.0	V
Driver Amplification Factor	ΔA_V		12		18	dB

Horizontal Part

Oscillation Start Voltage	$V_{OSC(H)}$				4.0	V
Free-Running Frequency	f_H	$f_H = 15.734KHz$	-750		750	Hz
AFC DC Loop Current	I_{AFC}		± 0.85		± 1.6	mA
Frequency Drift with Supply Voltage	$\Delta f_H/V_{CC}$	$V_{10} = 12 \pm 1V$, 15.734KHz at 12V	-50		50	Hz
Frequency Drift with Ambient Temperature	$\Delta f_V/T_A$	$T_a = -10$ to $+60^\circ C$	-2.9		2.9	Hz/ $^\circ C$
Comparison Wave Shaping Input Voltage	V_4		0.6		0.9	V
X-Ray Protector Starting Voltage	V_{13}		0.5		0.8	V
Horizontal Drive Current	I_{12}		6.0		12.0	mA

TYPICAL APPLICATION CIRCUIT

14" color monitor (f_v : 60Hz, f_H = 15.734KHz)

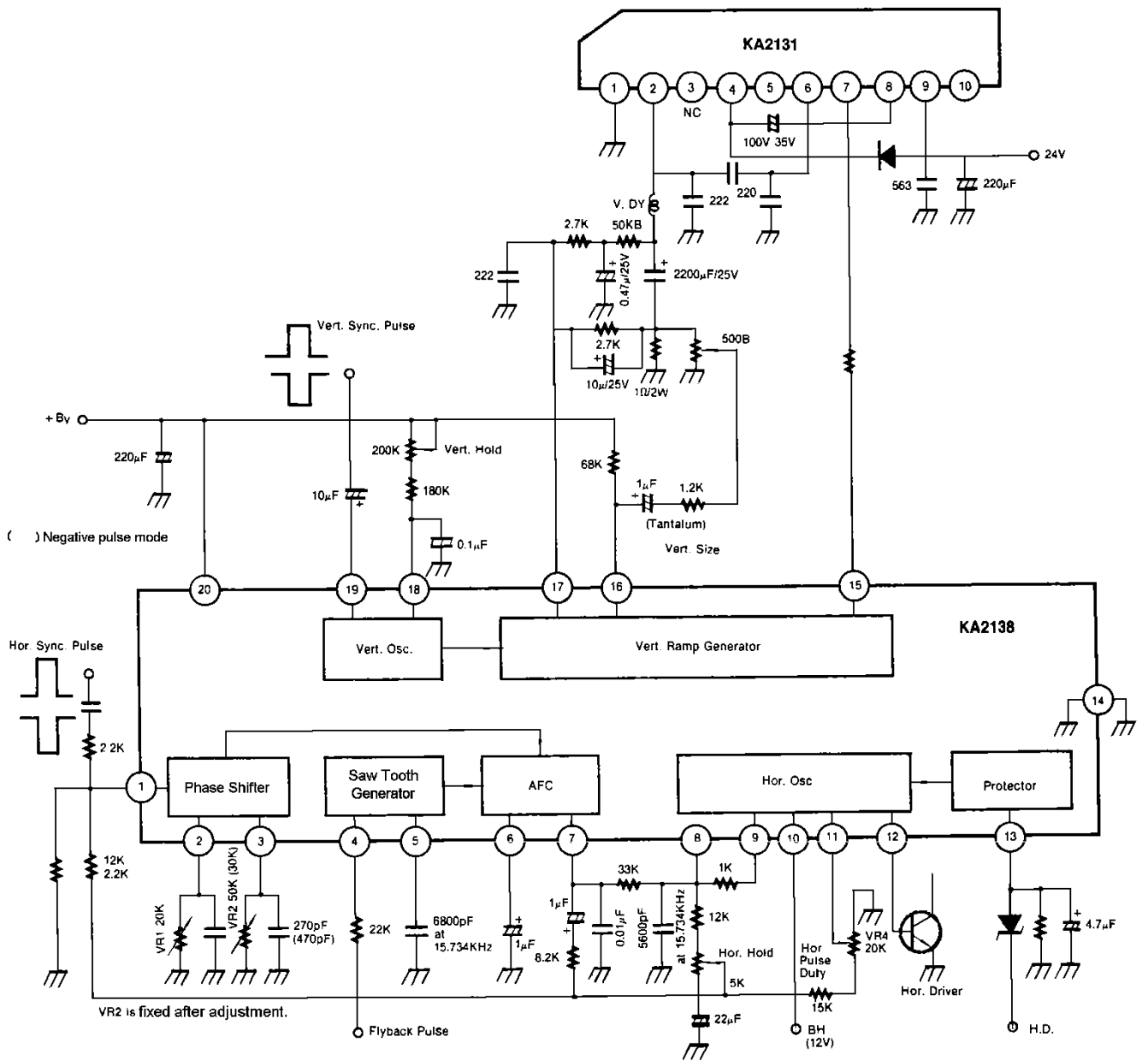



LittleDiode supplies new, hard to find or obsolete electronic components and semiconductors all over the world.

With over two million different components listed you are sure to find the part you need.

Feel free to visit us today at our online store:

LittleDiode.com

Looking forward to providing you with the best possible service.