

DUAL 5V REGULATOR WITH RESET AND DISABLE

PRELIMINARY DATA

- DOUBLE BATTERY OPERATING
- OUTPUT CURRENTS : $I_{O1} = 300 \text{ mA}$
 $I_{O2} = 300 \text{ mA}$
- FIXED PRECISION OUTPUT VOLTAGE
 $5 \text{ V} \pm 2 \%$
- RESET FUNCTION CONTROLLED BY INPUT VOLTAGE AND OUTPUT 1 VOLTAGE
- RESET FUNCTION EXTERNALLY PROGRAMMABLE TIMING
- RESET OUTPUT LEVEL RELATED TO OUTPUT 2
- OUTPUT 2 INTERNALLY SWITCHED WITH ACTIVE DISCHARGING
- OUTPUT 2 DISABLE LOGICAL INPUT
- LOW LEAKAGE CURRENT, LESS THAN $1 \mu\text{A}$ AT OUTPUT 1
- RESET OUTPUT NORMALLY HIGH
- INPUT OVERVOLTAGE PROTECTION UP TO 60V
- OUTPUT TRANSISTORS SOA PROTECTION
- SHORT CIRCUIT AND THERMAL OVERLOAD PROTECTION

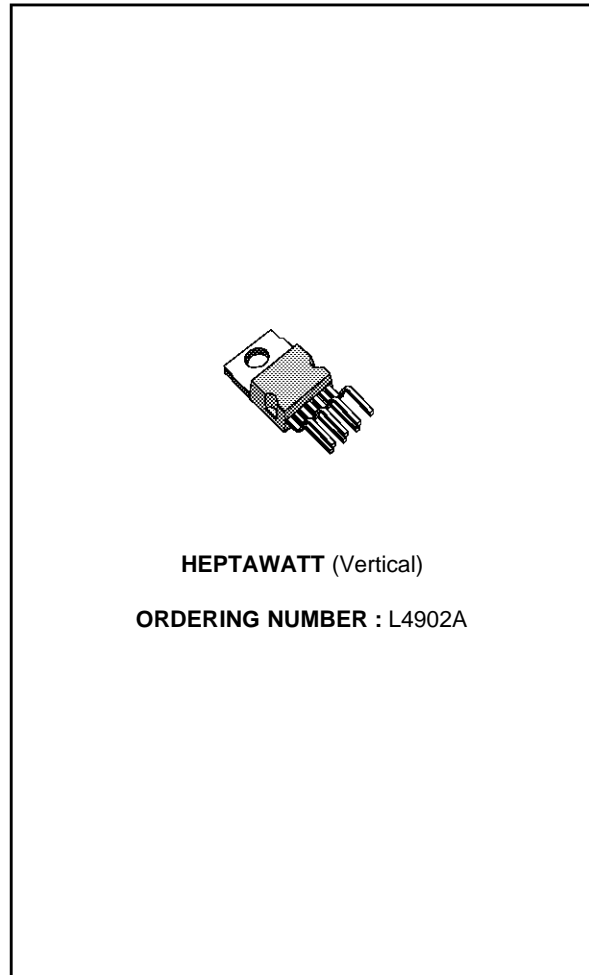

DESCRIPTION

The L4902A is a monolithic low drop dual 5V regulator designed mainly for supplying microprocessor systems.

Reset and data save functions and remote switch on/off control can be realized.

PIN CONNECTION

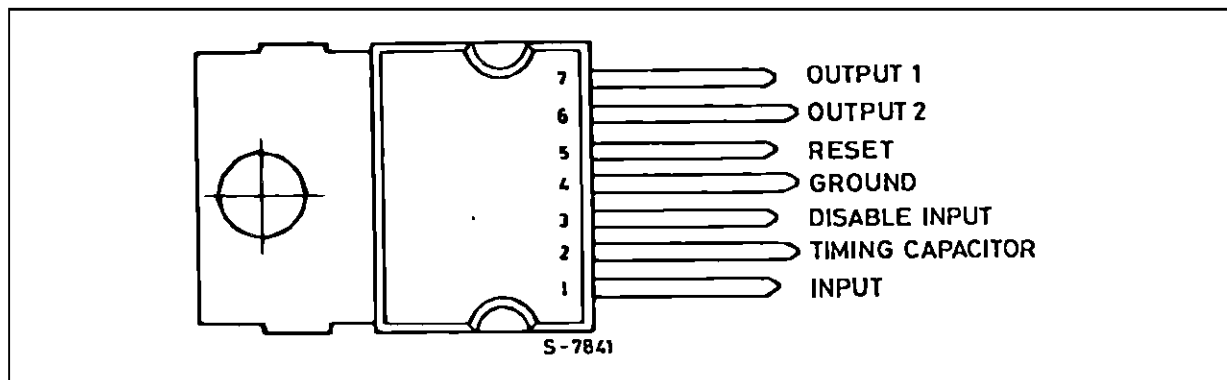

L4902A

PIN FUNCTIONS

N°	Name	Function
1	Input 1	Regulators Common Input
2	Timing Capacitor	If Reg. 2 is switched-ON the delay capacitor is charged with a 5µA constant current. When Reg. 2 is switched-OFF the delay capacitor is discharged.
3	Disable Input	A high level (> V _{DT}) disable output Reg. 2.
4	GND	Common Ground
5	Reset Output	When pin 2 reaches 5V the reset output is switched high. Therefore $t_{RD} = C_t \left(\frac{5V}{10\mu A} \right)$; $t_{RD} (ms) = C_t (nF)$
6	Output 2	5V – 300mA Regulator Output. Enabled if V _o 1 > V _{RT} . DISABLE INPUT < V _{DT} and V _{IN} > V _{IT} . If Reg. 2 is switched-OFF the C ₀₂ capacitor is discharged.
7	Output 1	5V – 300mA. Low leakage (in switch-OFF condition) output

BLOCK DIAGRAM

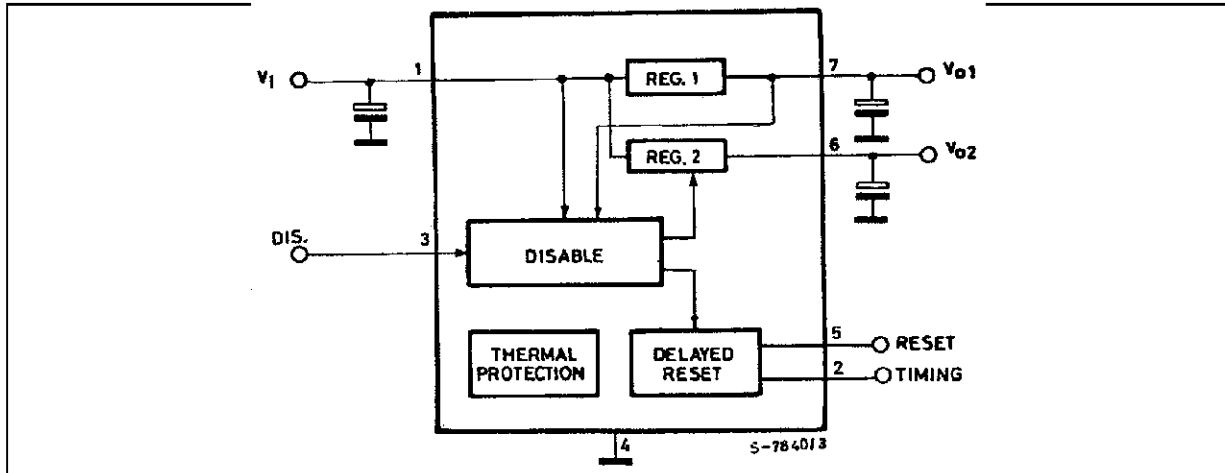

SCHEMATIC DIAGRAM

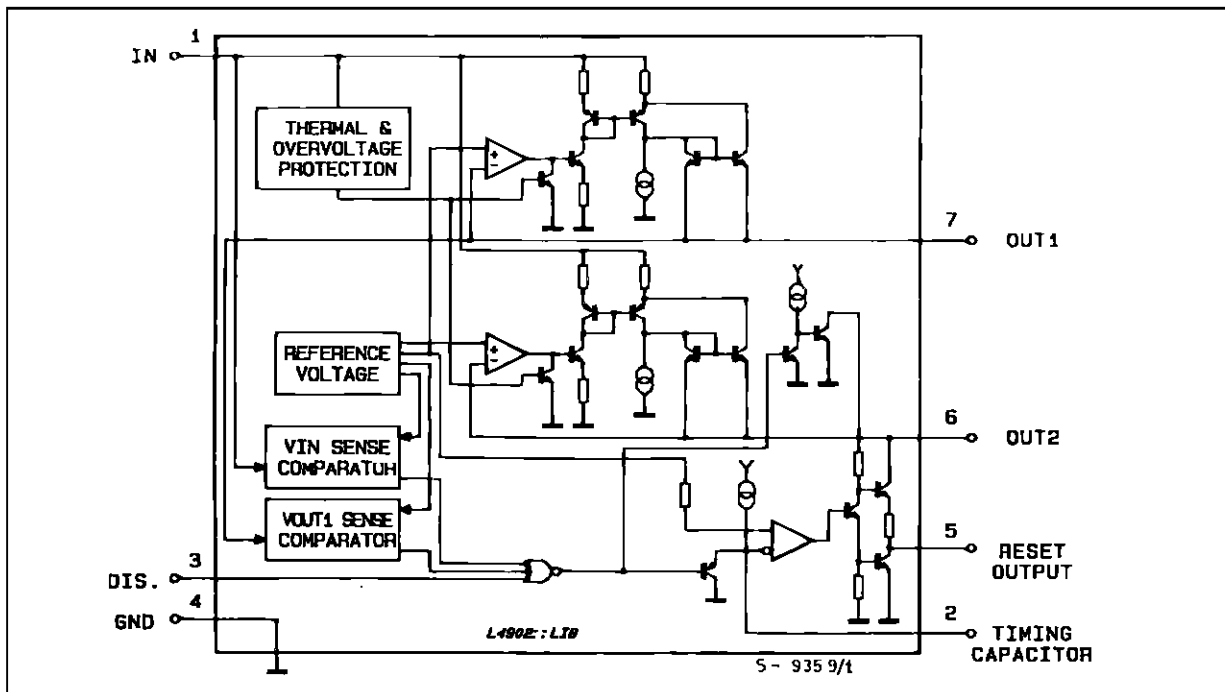

ABSOLUTE MAXIMUM RATINGS

Symbol	Parameter	Value	Unit
V_{IN}	DC Input Voltage Transient Input Overvoltage ($t = 40\text{ms}$)	28 60	V V
I_o	Output Current	Internally Limited	
T_{stg}, T_j	Storage and Junction Temperature	- 40 to 150	°C

THERMAL DATA

Symbol	Parameter	Value	Unit
$R_{th\ j\text{-case}}$	Thermal Resistance Junction-case	Max 4	°C/W

ELECTRICAL CHARACTERISTICS ($V_{IN} = 14.4\text{V}$, $T_{amb} = 25^\circ\text{C}$ unless otherwise specified)

Symbol	Parameter	Test Conditions	Min.	Typ.	Max.	Unit
V_i	DC Operating Input Voltage				24	V
V_{O1}	Output Voltage 1	R Load $1\text{k}\Omega$	4.95	5.05	5.15	V
$V_{O2\ H}$	Output Voltage 2 HIGH	R Load $1\text{k}\Omega$	$V_{O1} - 0.1$	5	V_{O1}	V
$V_{O2\ L}$	Output Voltage 2 LOW	$I_{O2} = -5\text{mA}$		0.1		V
I_{O1}	Output Current 1 max.	$\Delta V_{O1} = -100\text{mV}$	300			mA
I_{LO1}	Leakage Output 1 Current	$V_{IN} = 0, V_{O1} \leq 3\text{V}$			1	μA
I_{O2}	Output Current 2 max.	$\Delta V_{O2} = -100\text{mV}$	300			mA
V_{iO1}	Output 1 Dropout Voltage (*)	$I_{O1} = 10\text{mA}$ $I_{O1} = 100\text{mA}$ $I_{O1} = 300\text{mA}$		0.7 0.8 1.1	0.8 1 1.4	V V V
V_{IT}	Input Threshold Voltage		$V_{O1} + 1.2$	6.4	$V_{O1} + 1.7$	V
V_{iTH}	Input Threshold Voltage Hyst.			250		mV
ΔV_{O1}	Line Regulation 1	$7\text{V} < V_{IN} < 24\text{V}, I_{O1} = 5\text{mA}$		5	50	mV
ΔV_{O2}	Line Regulation 2	$7\text{V} < V_{IN} < 24\text{V}, I_{O2} = 5\text{mA}$		5	50	mV
ΔV_{O1}	Load Regulation 1	$5\text{mA} < I_{O1} < 300\text{mA}$		40	80	mV
ΔV_{O2}	Load Regulation 2	$5\text{mA} < I_{O2} < 300\text{mA}$		50	80	mV
I_Q	Quiescent Current	$I_{O1} = I_{O2} \leq 5\text{mA}$ $0 < V_{IN} < 13\text{V}$ $7\text{V} < V_{IN} < 13\text{V}, V_{O2}\ \text{LOW}$ $7\text{V} < V_{IN} < 13\text{V}, V_{O2}\ \text{HIGH}$		4.5 2.7 1.6	6.5 4.5 3.5	mA
V_{RT}	Reset Threshold Voltage		$V_{O2} - 0.15$	4.9	$V_{O2} - 0.05$	V
V_{RTH}	Reset Threshold Hysteresis		30	50	80	mV
V_{RH}	Reset Output Voltage HIGH	$I_R = 500\mu\text{A}$	$V_{O2} - 1$	4.12	V_{O2}	V
V_{RL}	Reset Output Voltage LOW	$I_R = -1\text{mA}$		0.25	0.4	V
t_{RD}	Reset Pulse Delay	$C_t = 10\text{nF}$	3	5	11	ms
t_d	Timing Capacitor Discharge Time	$C_t = 10\text{nF}$			20	μs
V_{DT}	V_{O2} Disable Threshold Voltage			1.25	2.4	V
I_D	V_{O2} Disable Input Current	$V_D \leq 0.4\text{V}$ $V_D \geq 2.4\text{V}$		- 150 - 30		μA μA
$\frac{\Delta V_{O1}}{\Delta T}$	Thermal Drift	$-20^\circ\text{C} \leq T_{amb} \leq 125^\circ\text{C}$		0.3 -0.8		mV/°C
$\frac{\Delta V_{O2}}{\Delta T}$	Thermal Drift	$-20^\circ\text{C} \leq T_{amb} \leq 125^\circ\text{C}$		0.3 -0.8		mV/°C
SVR1	Supply Voltage Rejection	$f = 100\text{Hz}, V_R = 0.5\text{V}$ $I_o = 100\text{mA}$	50	84		dB
SVR2	Supply Voltage Rejection		50	80		dB
T_{JSD}	Thermal Shut Down			150		°C

* The dropout voltage is defined as the difference between the input and the output voltage when the output voltage is lowered of 25 mV under constant output current condition.

TEST CIRCUIT

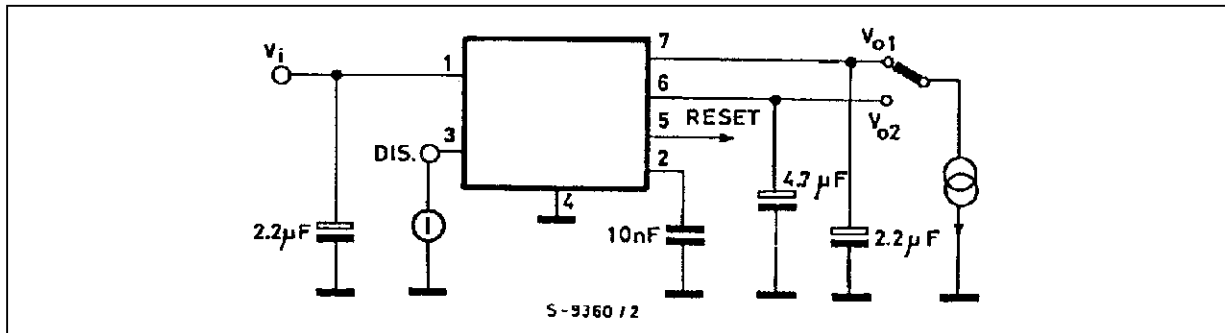

APPLICATION INFORMATION

In power supplies for μP systems it is necessary to provide power continuously to avoid loss of information in memories and in time of day clocks, or to save data when the primary supply is removed. The L4902A makes it very easy to supply such equipments ; it provides two voltage regulators (both 5V high precision) with common inputs plus a reset output for the data save function and a Reg. 2 disable input.

programmable time T_{RD} (timing capacitor).

V_{o2} and V_R are switched together at low level when one of the following conditions occurs :

- a high level (V_{DT}) is applied on pin 3 ;
- an input overvoltage ;
- an overload on the output 1 ($V_{o1} > V_{RT}$) ;
- a switch off ($V_{IN} < V_{IT} - V_{ITH}$) ;

and they start again as before when the condition is removed.

An overload on output 2 does not switch Reg. 2, and does not influence Reg. 1.

CIRCUIT OPERATION (see Figure 1)

After switch on Reg. 1 saturates until V_{o1} rises to the nominal value.

The V_{o1} output features :

- 5V internal reference without voltage divider between the output and the error comparator
- very low drop series regulator element utilizing current mirrors

When the input reaches V_{IT} and the output 1 is higher than V_{RT} the output 2 (V_{o2}) switches on and the reset output (V_R) also goes high after a pro-

permit high output impedance and then very low leakage current even in power down condition.

Figure 1

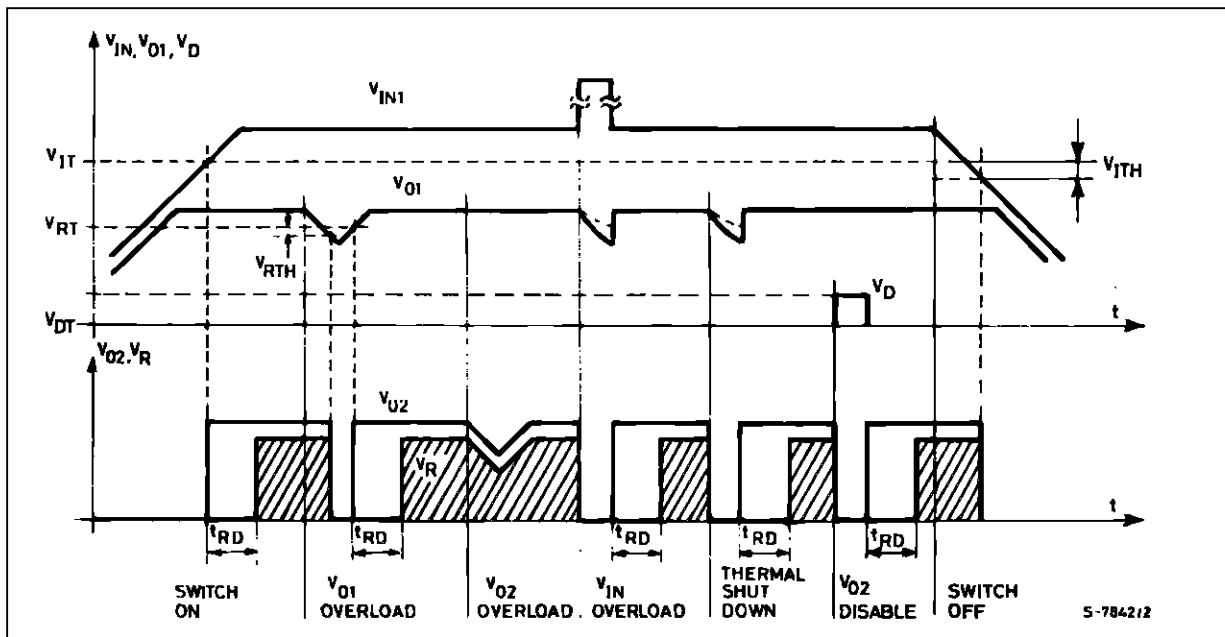

This output may therefore be used to supply circuits continuously, such as volatile RAMs, allowing the use of a back-up battery.

The V_{O2} output can supply other non essential 5 V circuits which may be powered down when the system is inactive, or that must be powered down to prevent uncorrect operation for supply voltages below the minimum value.

The reset output can be used as a "POWER DOWN INTERRUPT", permitting RAM access only in correct power conditions, or as a "BACK-UP ENABLE" to transfer data into in a NV SHADOW MEMORY

when the supply is interrupted.

The disable function can be used for remote on/off control of circuits connected to the V_{O2} output.

APPLICATION SUGGESTIONS

Figure 2 illustrate how the L4902A's disable input may be used in a CMOS μ Computer application. The V_{O1} regulator (low consumption) supply permanently a CMOS time of day clock and a CMOS μ computer chip with volatile memory. V_{O2} output, supplying non-essential circuits, is turned OFF under control of a μ P unit.

Figure 2

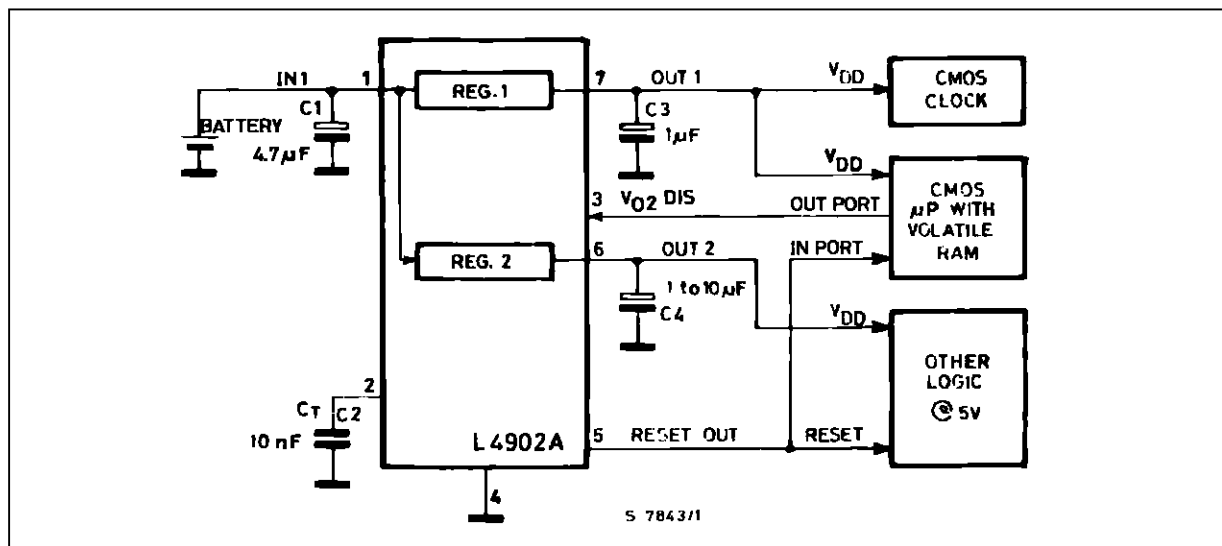
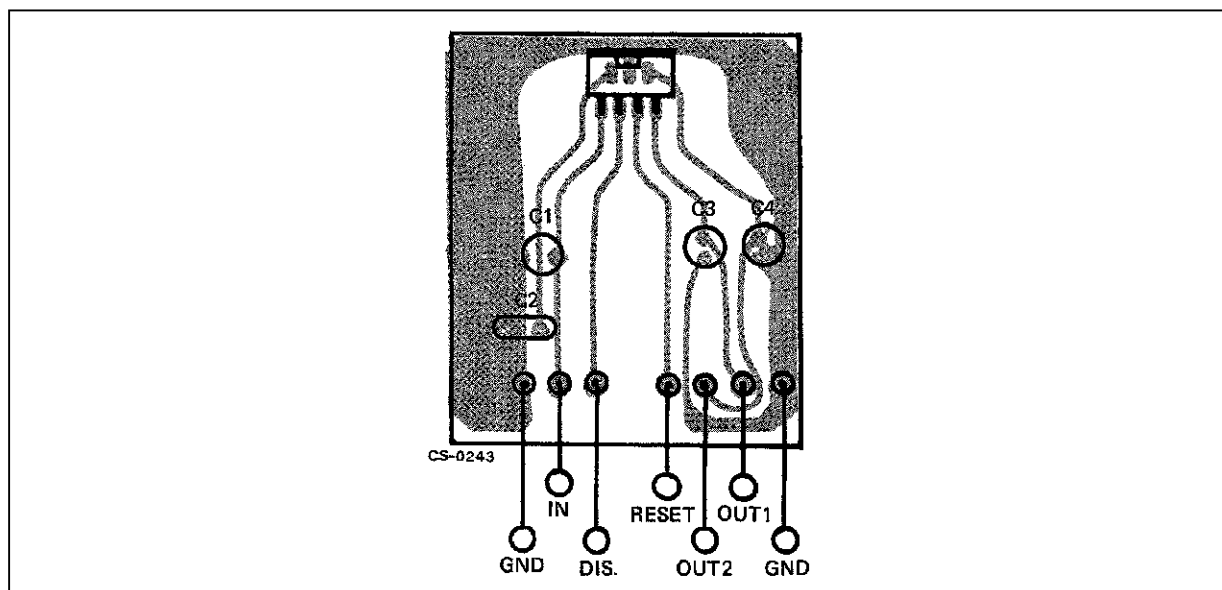

Figure 3 : P.C. Board Component Layout of Figure 2



L4902A

Configurations of this type are used in products where the OFF switch is part of a keyboard scanned by a micro which operates continuously even in the OFF state.

Another application for the L4902A is supplying a shadow-ram microcomputer chip (SGS M38SH72 for example) where a fast NV memory is backed up on chip by a EEPROM when a low level on the reset output occurs.

By adding two CMOS-SCHMIDT-TRIGGER and few external components, also a watch dog func-

tion may be realized (see Figure 5). During normal operation the microsystem supplies a periodical pulse waveform ; if an anomalous condition occurs (in the program or in the system), the pulses will be absent and the disable input will be activated after a settling time determined by R1 C1. In this condition all the circuitry connected to V_{O2} will be disabled, the system will be restarted with a new reset front.

The disable of V_{O2} prevent spurious operation during microprocessor malfunctioning.

Figure 4

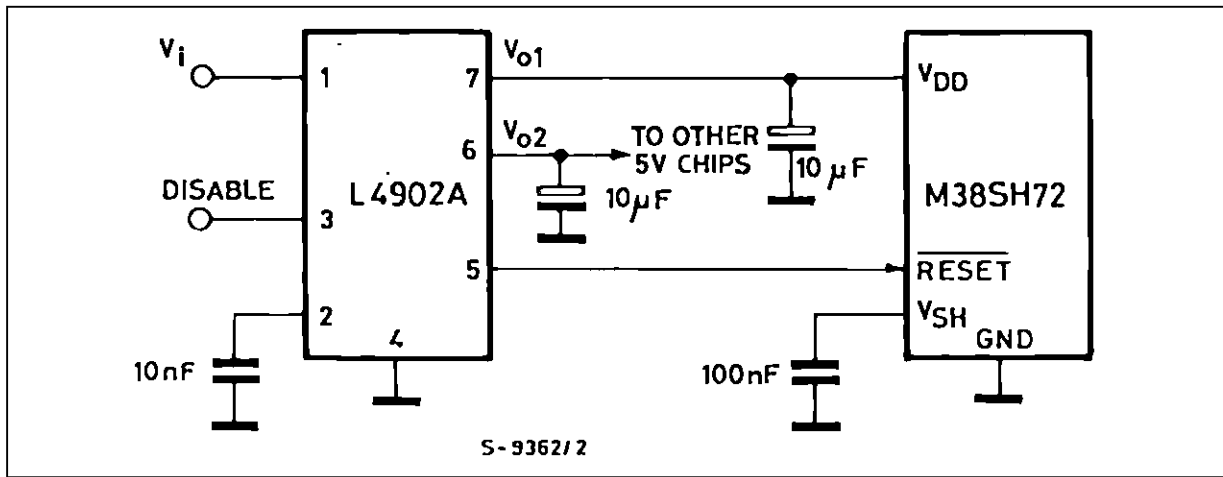

Figure 5

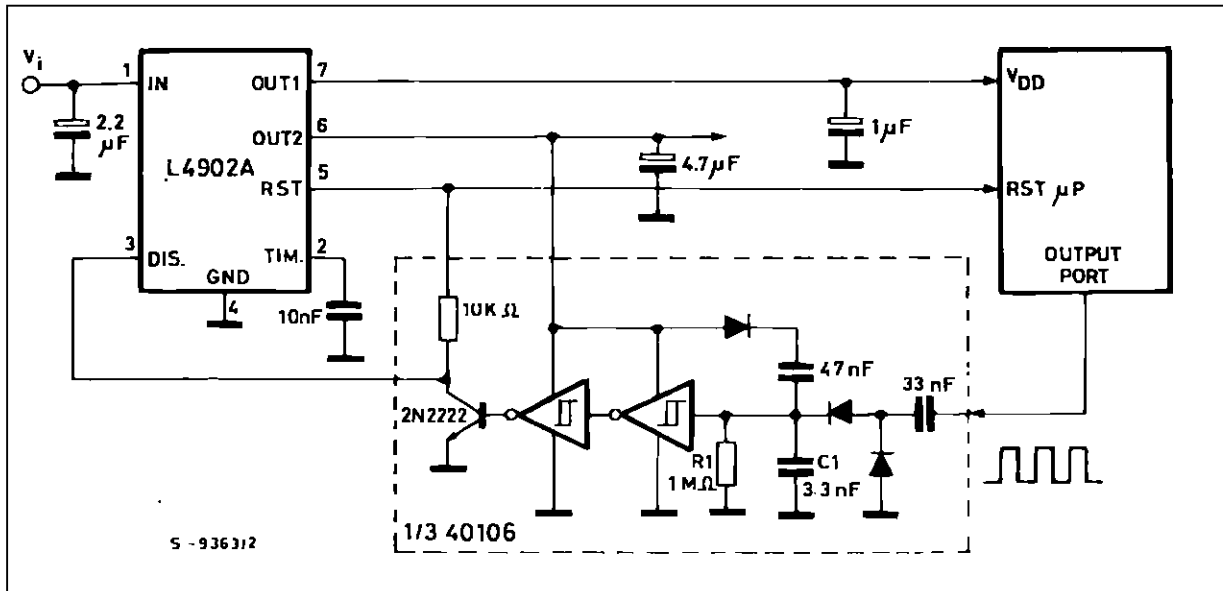

Figure 6 : Quiescent Current versus Output Current

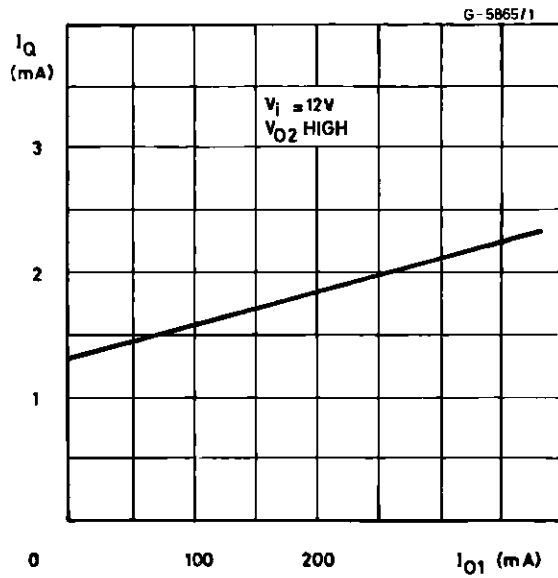

Figure 7 : Quiescent Current versus Input Voltage

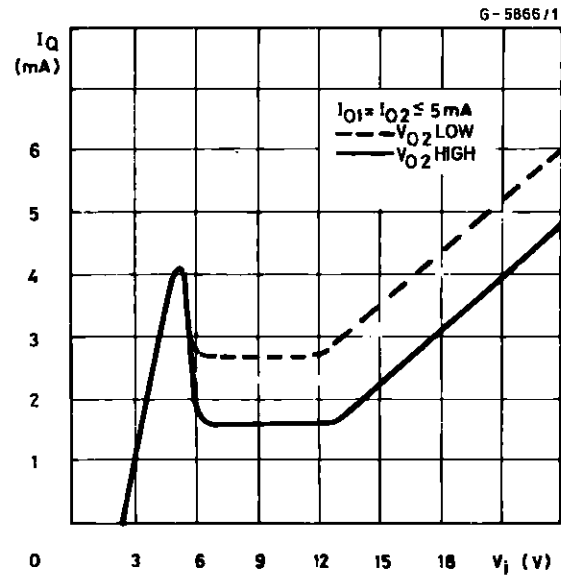
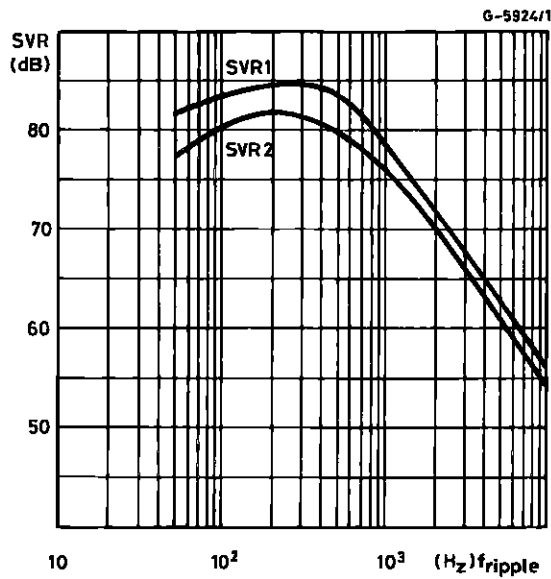
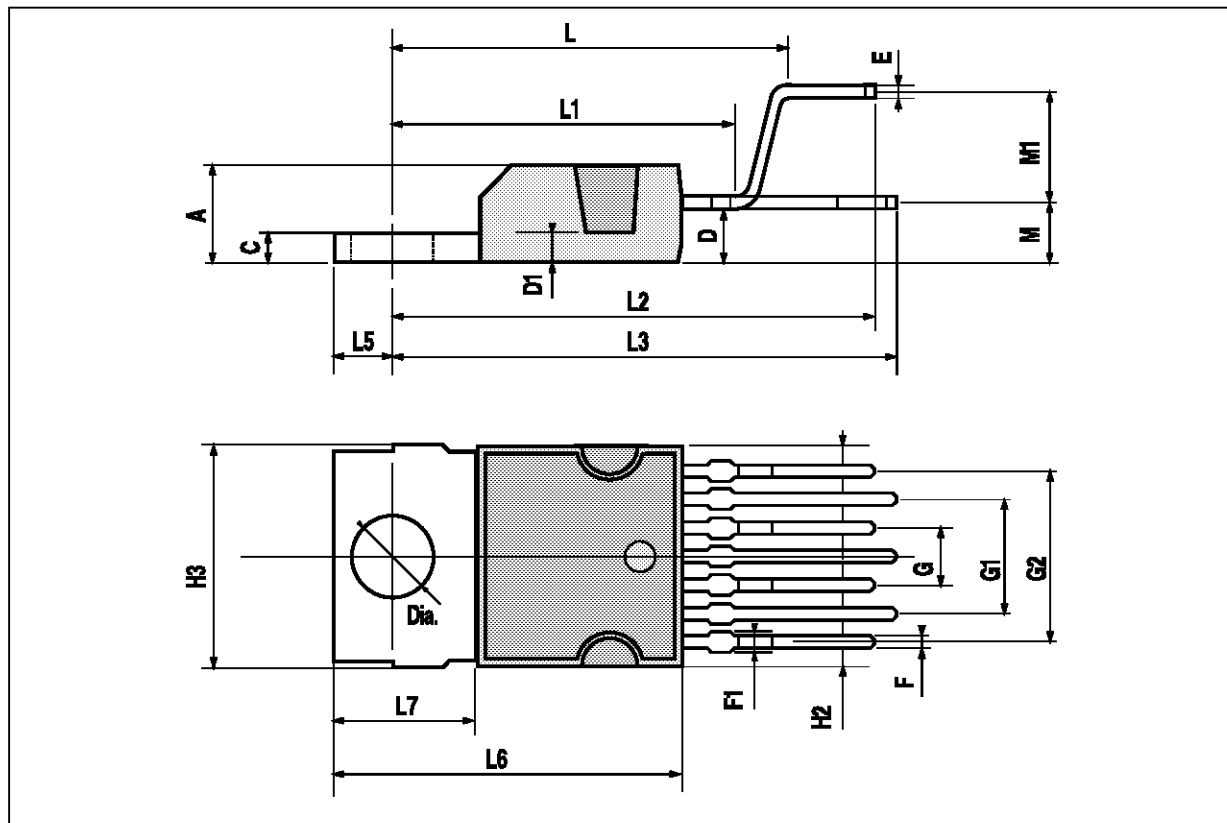

Figure 8 : Supply Voltage Rejection Regulators 1 and 2 versus Input Ripple Frequency



HEPTAVATT PACKAGE MECHANICAL DATA

DIM.	mm			inch		
	MIN.	TYP.	MAX.	MIN.	TYP.	MAX.
A			4.8			0.189
C			1.37			0.054
D	2.4		2.8	0.094		0.110
D1	1.2		1.35	0.047		0.053
E	0.35		0.55	0.014		0.022
F	0.6		0.8	0.024		0.031
F1			0.9			0.035
G	2.41	2.54	2.67	0.095	0.100	0.105
G1	4.91	5.08	5.21	0.193	0.200	0.205
G2	7.49	7.62	7.8	0.295	0.300	0.307
H2			10.4			0.409
H3	10.05		10.4	0.396		0.409
L		16.97			0.668	
L1		14.92			0.587	
L2		21.54			0.848	
L3		22.62			0.891	
L5	2.6		3	0.102		0.118
L6	15.1		15.8	0.594		0.622
L7	6		6.6	0.236		0.260
M		2.8			0.110	
M1		5.08			0.200	
Dia	3.65		3.85	0.144		0.152



Information furnished is believed to be accurate and reliable. However, SGS-THOMSON Microelectronics assumes no responsibility for the consequences of use of such information nor for any infringement of patents or other rights of third parties which may result from its use. No license is granted by implication or otherwise under any patent or patent rights of SGS-THOMSON Microelectronics. Specifications mentioned in this publication are subject to change without notice. This publication supersedes and replaces all information previously supplied. SGS-THOMSON Microelectronics products are not authorized for use as critical components in life support devices or systems without express written approval of SGS-THOMSON Microelectronics.

© 1994 SGS-THOMSON Microelectronics - All Rights Reserved

SGS-THOMSON Microelectronics GROUP OF COMPANIES

Australia - Brazil - France - Germany - Hong Kong - Italy - Japan - Korea - Malaysia - Malta - Morocco - The Netherlands - Singapore - Spain - Sweden - Switzerland - Taiwan - Thailand - United Kingdom - U.S.A.