

MITSUBISHI (DGTL LOGIC)

**M54565P****8-UNIT 50mA TRANSISTOR ARRAY**  
(“L” ACTIVE INPUT)**DESCRIPTION**

The M54565P, 8-channel sink driver, consists of 7 PNP and 7 NPN transistors connected to form high current gain driver pairs.

**FEATURES**

- Output breakdown voltage to 20V
- Output sink current to 50mA
- Wide operating temperature range ( $T_a = -20 \sim +75^\circ\text{C}$ )
- Low-level Active Input

**APPLICATION**

LED or incandescent display driver, Interfacing for standard MOS/BIPOLAR logics

**FUNCTION**

The M54565P is comprised of eight PNP-NPN non darlington sink drivers. It functions from 2 V of supply voltage and features low output saturation voltage. The output is turned ON by switching the input low.

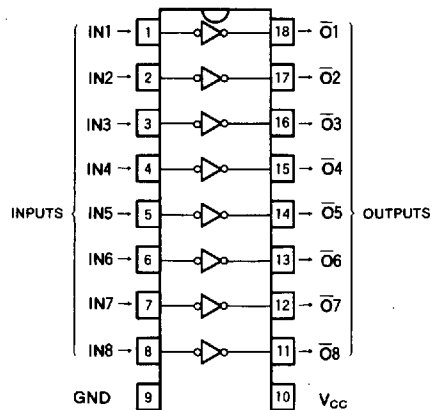
**PIN CONFIGURATION (TOP VIEW)**

Outline 18P4

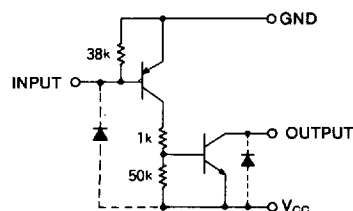
**CIRCUIT SCHEMATIC**

The diodes shown by broken line are parasite diodes and must not be used

Unit :  $\Omega$ **ABSOLUTE MAXIMUM RATINGS** ( $T_a = -20 \sim +75^\circ\text{C}$ , unless otherwise noted)

Symbol	Parameter	Conditions	Ratings	Unit
$V_{CC}$	Supply voltage		10	V
$V_{CEO}$	Output sustaining voltage	Transistor OFF	-0.5 ~ +20	V
$I_C$	Collector current	Transistor ON	50	mA
$V_I$	Input voltage		0 ~ $V_{CC}$	V
$T_{opr}$	Operating temperature		-20 ~ +75	$^\circ\text{C}$
$T_{stg}$	Storage temperature		-55 ~ +125	$^\circ\text{C}$

**RECOMMENDED OPERATIONAL CONDITIONS** ( $T_a = -20 \sim +75^\circ\text{C}$ , unless otherwise noted)

Symbol	Parameter	Limits			Unit
		Min	Typ	Max	
$V_{CC}$	Supply voltage	2		6	V
$V_O$	Output voltage	0		20	V
$I_C$	Collector current	0		20	mA
$I_{IH}$	"H" Input current	-8		8	$\mu\text{A}$
$I_{IL}$	"L" Input current	-200		-5000	$\mu\text{A}$

**ELECTRICAL CHARACTERISTICS** ( $T_a = -20 \sim +75^\circ\text{C}$ , unless otherwise noted)

Symbol	Parameter	Test conditions	Limits			Unit
			Min	Typ*	Max	
$I_{C(LEAK)}$	Output leakage current	$V_{CC} = 6\text{V}, V_O = 20\text{V}$			50	$\mu\text{A}$
$V_{CE(sat)}$	Output saturation voltage	$V_{CC} = 3\text{V}$ $I_i = -200\mu\text{A}$		0.03	0.17	V
$V_i$	Input voltage	$V_{CC} = 2\text{V}, I_i = -200\mu\text{A}$	1	1.25		V
$I_{CC}$	Supply current	$V_{CC} = 3\text{V}, I_i = -200\mu\text{A}$		2.3	4	mA
$h_{FE}$	DC forward current gain	$V_{CC} = 4\text{V}, V_{CE} = 3\text{V}, I_C = 40\text{mA}, T_a = 25^\circ\text{C}$	800	2500		—

\* : Typical values are at  $T_a = 25^\circ\text{C}$ .

**TYPICAL CHARACTERISTICS**

**OUTPUT CURRENT CHARACTERISTICS**

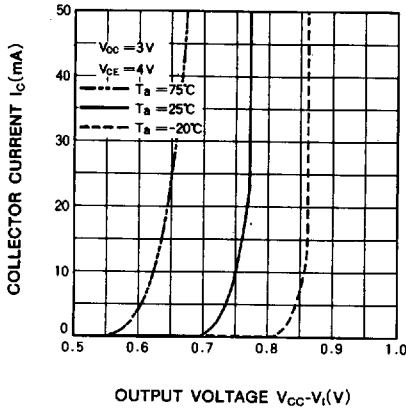

**DC CURRENT GAIN CHARACTERISTICS**

