



## QUAD PRECISION HIGH SPEED MICROPOWER TIMER

### GENERAL DESCRIPTION

The ALD4501 timer is a high performance QUAD monolithic timing circuit built with advanced silicon gate CMOS technology. It offers the benefits of high input impedance, thereby allowing smaller timing capacitors and longer timing cycle; high speed with typical cycle time of 500ns; low power dissipation for battery operated environment; and reduced supply current spikes allowing smaller and lower cost decoupling capacitors. Each of the four timers can be independently operated in either the monostable, astable, or 50% duty cycle mode.

Each timer is capable of producing accurate time delays and oscillations in both monostable and astable operation. It operates in the one-shot (monostable) mode or 50% duty cycle free running oscillation mode with a single resistor and one capacitor. The inputs and outputs are fully compatible with CMOS, NMOS or TTL logic.

There are three matched internal resistors (approximately 200KΩ each) that set the threshold and trigger levels at two-thirds and one-third respectively of V+. These levels can be adjusted by using the control terminal. When the trigger input is below the trigger level, the output is in the high state and sourcing 2mA. When the threshold input is above the threshold level at the same time the trigger input is above the trigger level, the internal flip-flop is reset, the output goes to the low state and sinks up to 10mA. The reset input overrides all other inputs and when it is active (reset voltage less than 1V), the output is in the low state. All four timers share the same control and reset pins so that timing functions are synchronized.

### FEATURES

- High speed operation -- 2MHz typical oscillation at 5V
- Each discharge output sinking current: 40mA at 5V
- Guaranteed low operating supply voltage of 2 to 12V
- Each timer is functionally equivalent to NE555 with greatly expanded high and low frequency ranges
- High speed, low power, monolithic CMOS technology
- Low supply current 150µA typical
- Extremely low trigger, threshold and reset currents -- 10pA typical
- Operates in both monostable and astable modes
- Fixed 50% duty cycle or adjustable duty cycle
- CMOS, NMOS and TTL compatible input/output
- Low supply current spikes

### ORDERING INFORMATION

Operating Temperature Range *		
-55°C to +125°C	0°C to +70°C	0°C to +70°C
20-Pin CERDIP Package	20-Pin Small Outline Package (SOIC)	20-Pin Plastic Dip Package
ALD4501 DE	ALD4501 SE	ALD4501 PE

\* Contact factory for industrial temperature range

### APPLICATIONS.

- High speed one-shot (monostable) pulse generation
- Precision timing
- Sequential timing
- Long delay timer
- Pulse width and pulse position modulation
- Missing pulse detector
- Frequency divider
- Synchronized timer

### PIN CONFIGURATION

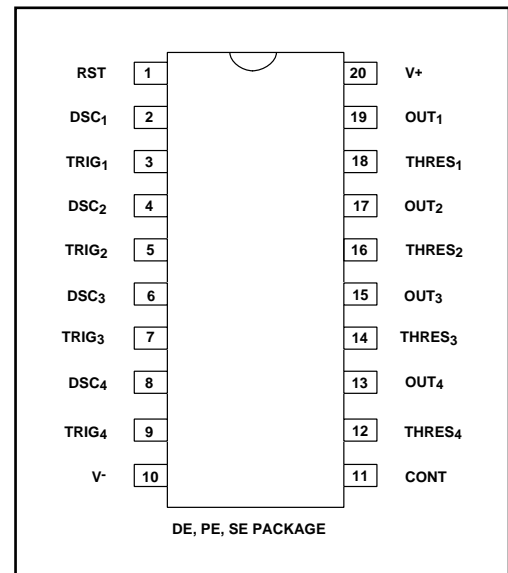

### BLOCK DIAGRAM (EACH TIMER)

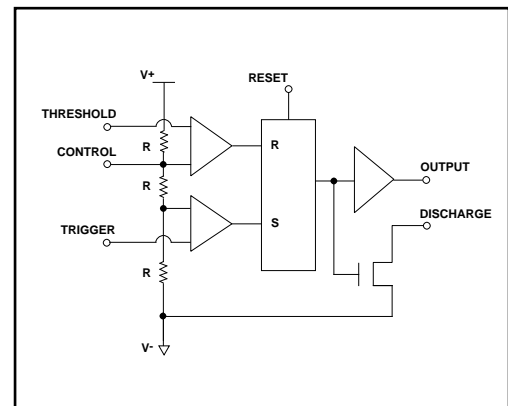



# TYPICAL PERFORMANCE CHARACTERISTICS

**DISCHARGE OUTPUT SINK CURRENT AS A FUNCTION OF DISCHARGE LOW VOLTAGE**

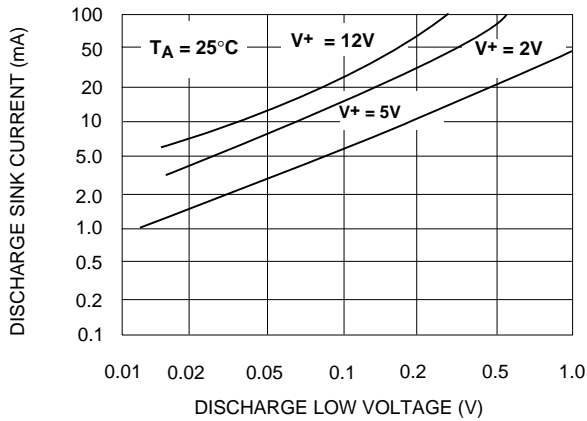

**MINIMUM PULSE WIDTH REQUIRED FOR TRIGGERING**

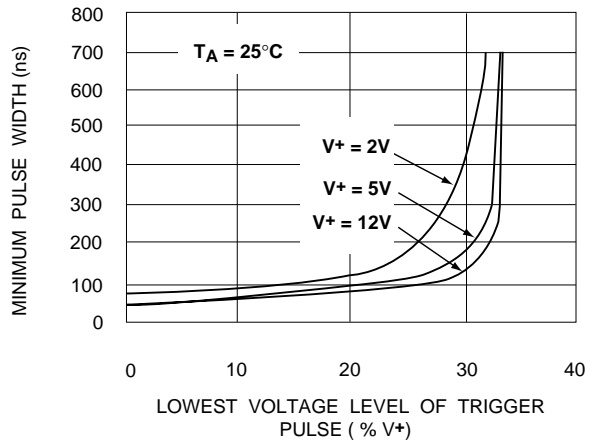

**FREE RUNNING FREQUENCY AS A FUNCTION OF  $R_A$ ,  $R_B$  AND C**

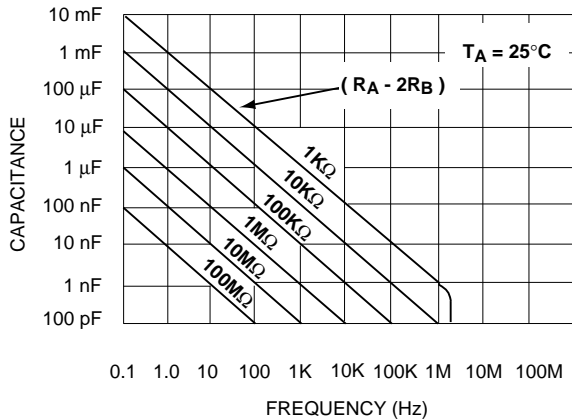

**FREQUENCY CHANGE IN THE ASTABLE MODE AS A FUNCTION OF SUPPLY VOLTAGE**

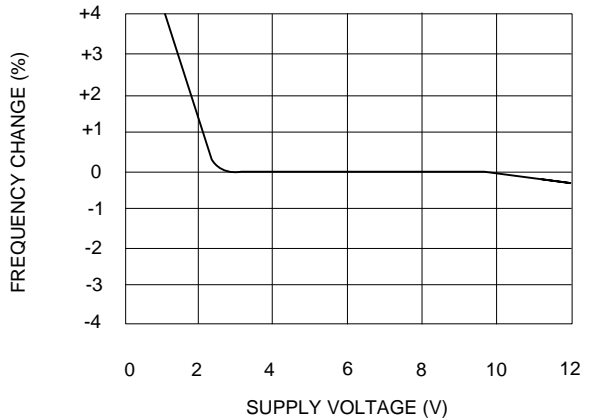

**TIME DELAY IN THE MONOSTABLE MODE AS A FUNCTION OF  $R_A$  AND C**

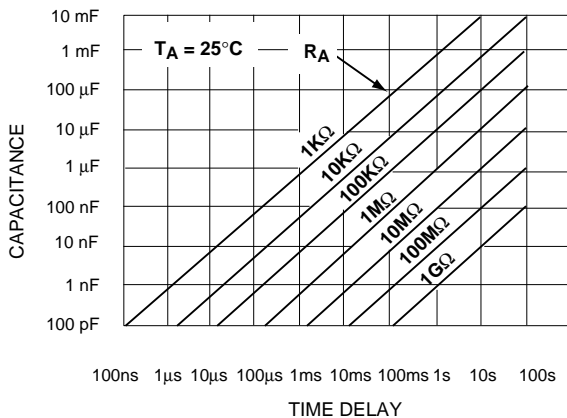

**SUPPLY CURRENT AS A FUNCTION OF SUPPLY VOLTAGE**

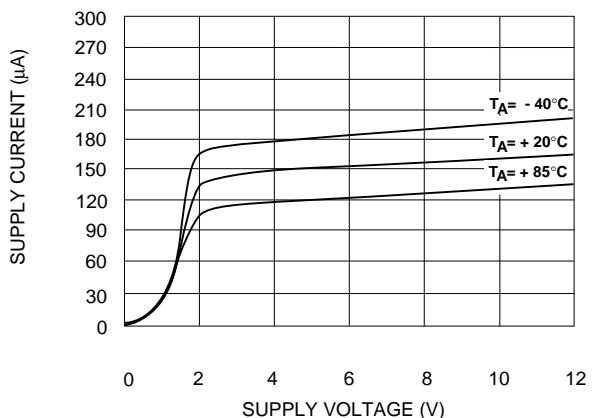

## TYPICAL PERFORMANCE CHARACTERISTICS

OUTPUT SINK CURRENT AS A FUNCTION OF OUTPUT VOLTAGE

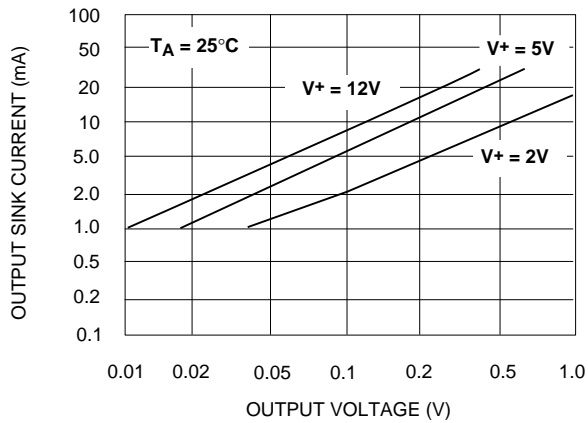

OUTPUT SOURCE CURRENT AS A FUNCTION OF OUTPUT VOLTAGE

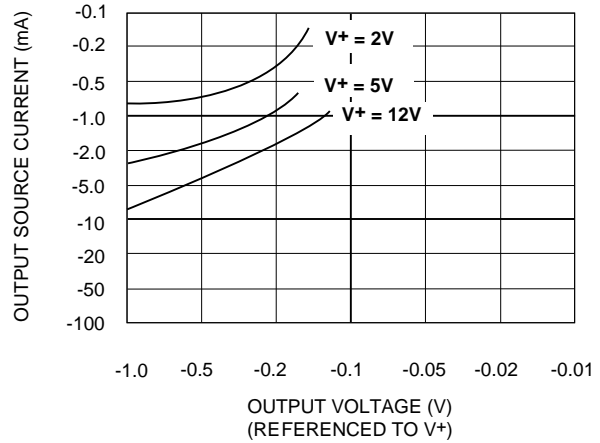

## TYPICAL APPLICATIONS

QUAD ASTABLE MODE OPERATION  
(FREE RUNNING OSCILLATOR)

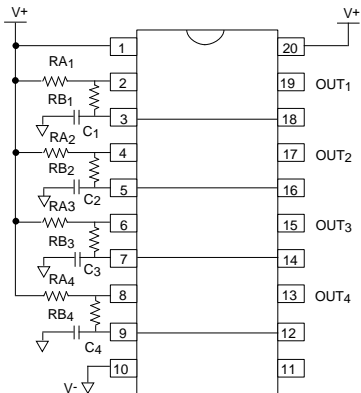

Frequency  $f = 1.46 / (R_A + 2R_B) C$   
 Duty Cycle  $DC = R_B / (R_A + 2R_B)$

QUAD MONOSTABLE MODE OPERATION  
(ONE SHOT PULSE)

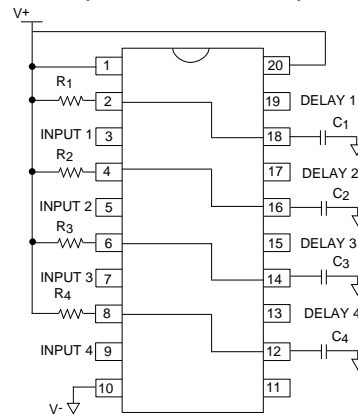

Pulse Delay  $t_d = 1.1R_C$

## SYNCHRONIZED TIMING GENERATORS

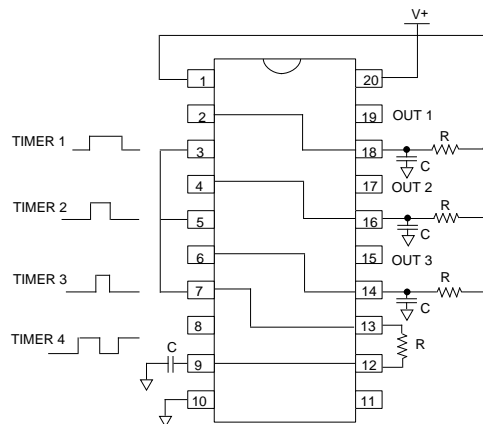

Timer 4 oscillates in free running mode (50% Duty Cycle) and drives the trigger inputs of timers 1,2,3, each with independently set time delays.



LittleDiode supplies new, hard to find or obsolete electronic components and semiconductors all over the world.

With over two million different components listed you are sure to find the part you need.

Feel free to visit us today at our online store:

[LittleDiode.com](http://LittleDiode.com)

Looking forward to providing you with the best possible service.