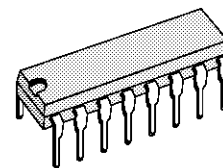


**LOW-NOISE TV VERTICAL DEFLECTION SYSTEM**

- COMPLETE VERTICAL DEFLECTION SYSTEM
- LOW NOISE
- SUITABLE FOR HIGH DEFINITION MONITORS

**DESCRIPTION**

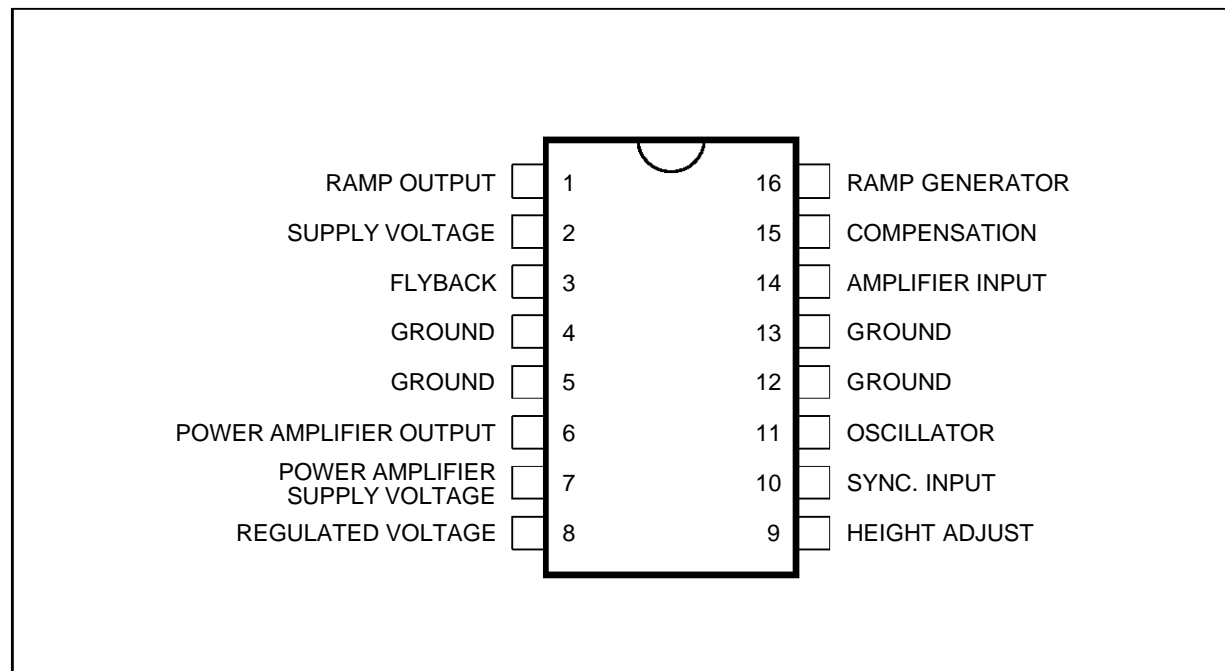
The TDA 1170D is a monolithic integrated circuit in a 16-lead dual in-line plastic package. It is intended for use in black and white and colour TV receivers. **Low-noise makes this device particularly suitable for use in monitors.** The functions incorporated are : synchronization circuit, oscillator and ramp generator, high power gain amplifier, flyback generator, voltage regulator.



**DIP16**  
(Plastic Package)

**ORDER CODE : TDA1170D**

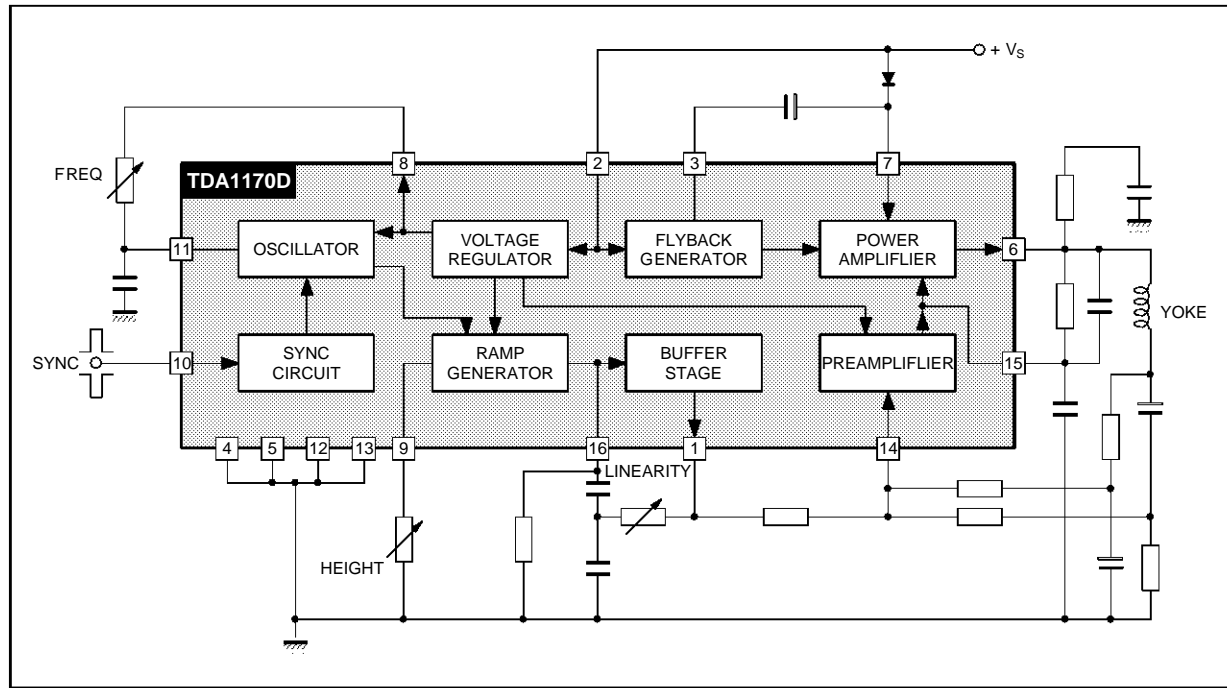
**PIN CONNECTIONS**



1170D-01 EPS

# TDA1170D

## BLOCK DIAGRAM



1170D-02.EPS

## ABSOLUTE MAXIMUM RATINGS

| Symbol         | Parameter   | Value         | Unit             |
|----------------|---|---------------|------------------|
| $V_s$          | Supply Voltage at Pin 2   | 35            | V                |
| $V_6, V_7$     | Flyback Peak Voltage  | 60            | V                |
| $V_{14}$       | Power Amplifier Input Voltage   | + 10<br>- 0.5 | V                |
| $I_o$          | Output Peak Current (non repetitive) at $t = 2\text{msec}$  | 2             | A                |
| $I_o$          | Output Peak Current at $f = 50\text{Hz}$ $t \leq 10\mu\text{sec}$                                 | 2.5           | A                |
| $I_o$          | Output Peak Current at $f = 50\text{Hz}$ $t > 10\mu\text{sec}$                                    | 1.5           | A                |
| $I_3$          | Pin 3 DC Current at $V_6 < V_2$   | 100           | mA               |
| $I_3$          | Pin 3 Peak to Peak Flyback Current for $f = 50\text{Hz}$ , $t_{fly} \leq 1.5\text{msec}$          | 1.8           | A                |
| $I_{10}$       | Pin 10 Current  | $\pm 20$      | mA               |
| $P_{tot}$      | Power Dissipation : at $T_{tab} = 90^\circ\text{C}$<br>at $T_{amb} = 70^\circ\text{C}$ (free air) | 4.3<br>1      | W                |
| $T_{stg}, T_j$ | Storage and Junction Temperature  | - 40 to 150   | $^\circ\text{C}$ |

1170D-01.TBL

## THERMAL DATA

| Symbol           | Parameter                           | Value  | Unit                 |
|------------------|-------------------------------------|--------|----------------------|
| $R_{th\ j-case}$ | Thermal Resistance Junction-pins    | Max 14 | $^\circ\text{C/W}$   |
| $R_{th\ j-amb}$  | Thermal Resistance Junction-ambient | Max 80 | $^\circ\text{C/W}^*$ |

\* Obtained with pins 4, 5, 12, 13 soldered to printed circuit with minimized copper area.

1170D-02.TBL

**ELECTRICAL CHARACTERISTICS**(refer to the test circuits,  $V_S = 35V$ ,  $T_{amb} = 25^{\circ}C$ , unless otherwise specified)**DC CHARACTERISTICS**

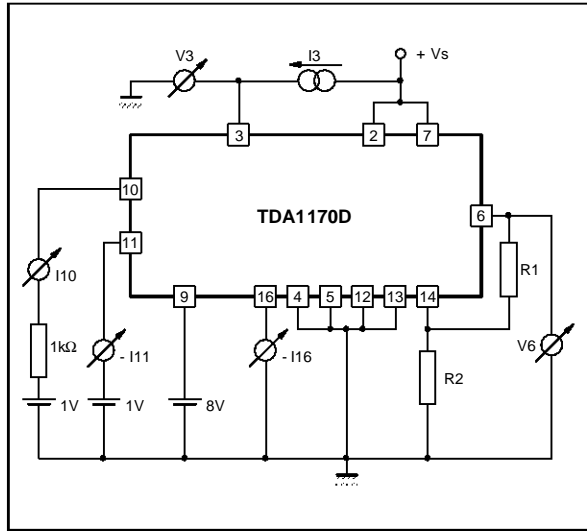
| Symbol  | Parameter                                   | Test Conditions                                  | Min. | Typ. | Max. | Unit       | Fig. |
|---|---|--|------|------|------|------------|------|
| $I_2$   | Pin 2 Quiescent Current                     | $I_3 = 0$  |      | 7    | 14   | mA         | 1b   |
| $I_7$   | Pin 7 Quiescent Current                     | $I_6 = 0$  |      | 8    | 17   | mA         | 1b   |
| $-I_{11}$   | Oscillator Bias Current                     | $V_{11} = 1V$                                    |      | 0.1  | 1    | $\mu A$    | 1a   |
| $-I_{14}$   | Amplifier Input Bias Current                | $V_{14} = 1V$                                    |      | 1    | 10   | $\mu A$    | 1b   |
| $-I_{16}$   | Ramp Generator Bias Current                 | $V_{16} = 0$                                     |      | 0.02 | 0.3  | $\mu A$    | 1a   |
| $-I_{16}$   | Ramp Generator Current                      | $I_9 = 20\mu A$ , $V_{16} = 0$                   | 18.5 | 20   | 21.5 | $\mu A$    | 1b   |
| $\frac{\Delta I_{16}}{I_{16}}$                                    | Ramp Generator Non-linearity                | $\Delta V_{16} = 0$ to 12V, $I_9 = 20\mu A$      |      | 0.2  | 1    | %          | 1b   |
| $V_S$   | Supply Voltage Range                        |  | 10   |      | 35   | V          | –    |
| $V_1$   | Pin 1 Saturation Voltage to Ground          | $I_1 = 1mA$                                      |      | 1    | 1.4  | V          | –    |
| $V_3$   | Pin 3 Saturation Voltage to Ground          | $I_3 = 10mA$                                     |      | 300  | 450  | mV         | 1a   |
| $V_6$   | Quiescent Output Voltage                    | $V_S = 10V$<br>$R1 = 1k\Omega$ , $R2 = 1k\Omega$ | 4.1  | 4.4  | 4.75 | V          | 1a   |
|   |   | $V_S = 35V$<br>$R1 = 3k\Omega$ , $R2 = 1k\Omega$ | 8.3  | 8.8  | 9.45 | V          | 1a   |
| $V_{6L}$  | Output Saturation Voltage to Ground         | $-I_6 = 0.1A$                                    |      | 0.9  | 1.2  | V          | 1c   |
|   |   | $-I_6 = 0.8A$                                    |      | 1.9  | 2.3  | V          | 1c   |
| $V_{6H}$  | Output Saturation Voltage to Supply         | $I_6 = 0.1A$                                     |      | 1.4  | 2.1  | V          | 1d   |
|   |   | $I_6 = 0.8A$                                     |      | 2.8  | 3.2  | V          | 1d   |
| $V_8$   | Regulated Voltage at Pin 8                  |  | 6.1  | 6.5  | 6.9  | V          | 1b   |
| $V_9$   | Regulated Voltage at Pin 9                  | $I_9 = 20\mu A$                                  | 6.2  | 6.6  | 7    | V          | 1b   |
| $\frac{\Delta V_8}{\Delta V_S}$ , $\frac{\Delta V_9}{\Delta V_S}$ | Regulated Voltage Drift with Supply Voltage | $\Delta V_S = 10$ to 35V                         |      | 1    |      | mV/V       | 1b   |
| $V_{14}$  | Amplifier Input Reference Voltage           |  | 2.07 | 2.2  | 2.3  | V          | –    |
| R10   | Pin 10 Input Resistance                     | $V_{10} \leq 0.4V$                               | 1    |      |      | M $\Omega$ | 1a   |

1170D-03.TBL

# TDA1170D

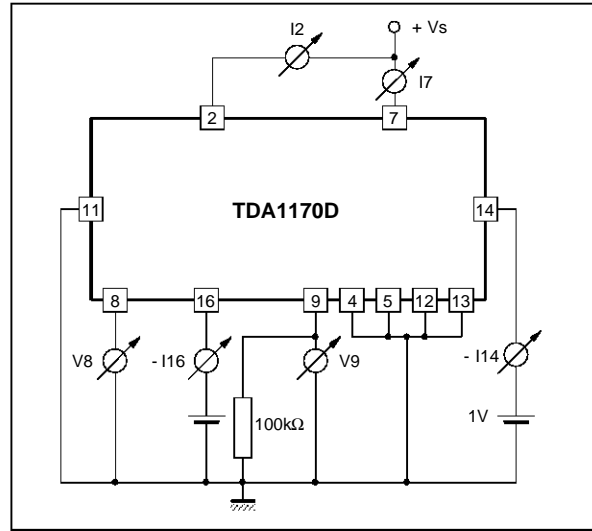
Figure 1 : DC Test Circuit

Figure 1a



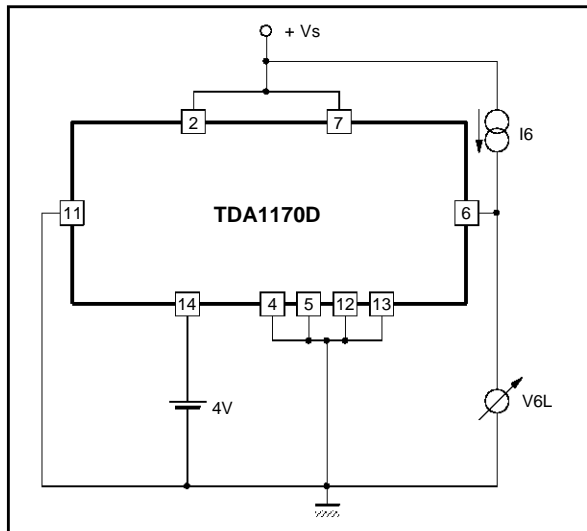
1170D-03.EPS

Figure 1b



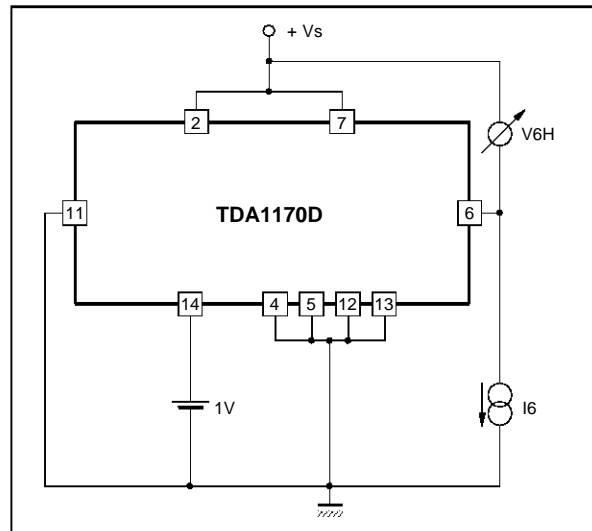
1170D-04.EPS

Figure 1c



1170D-05.EPS

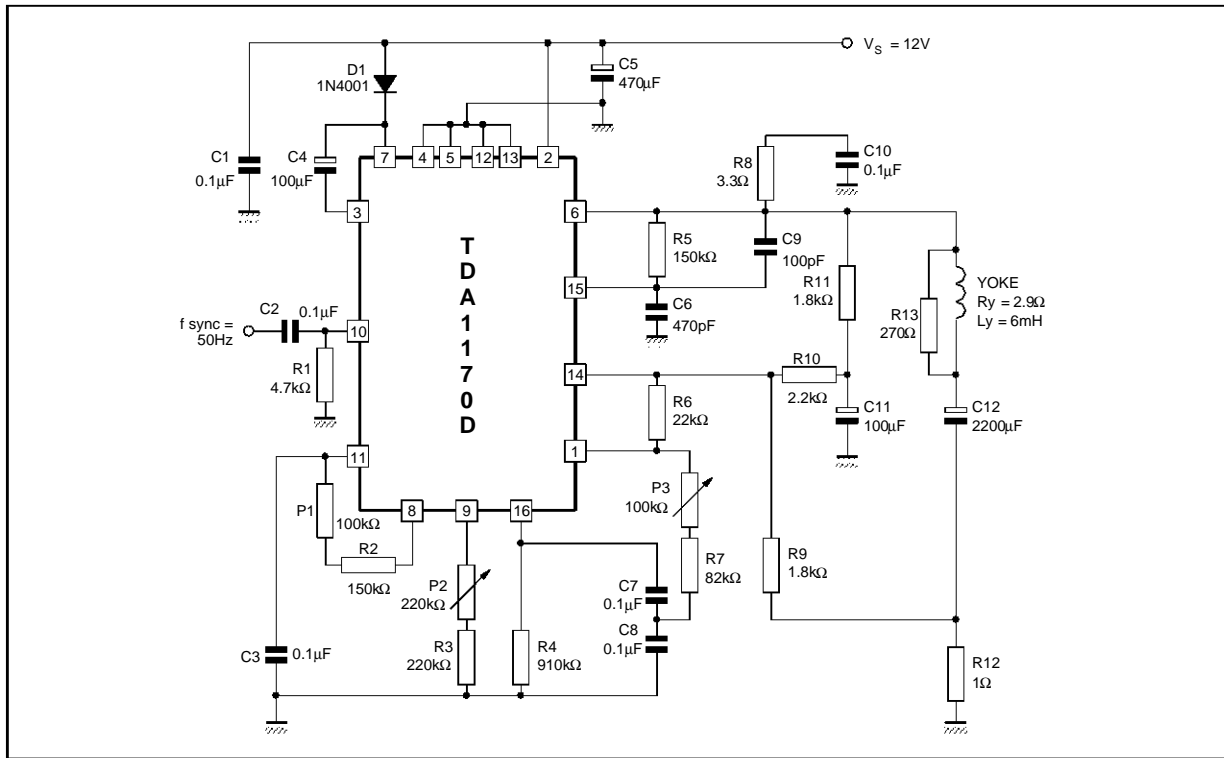
Figure 1d



1170D-06.EPS

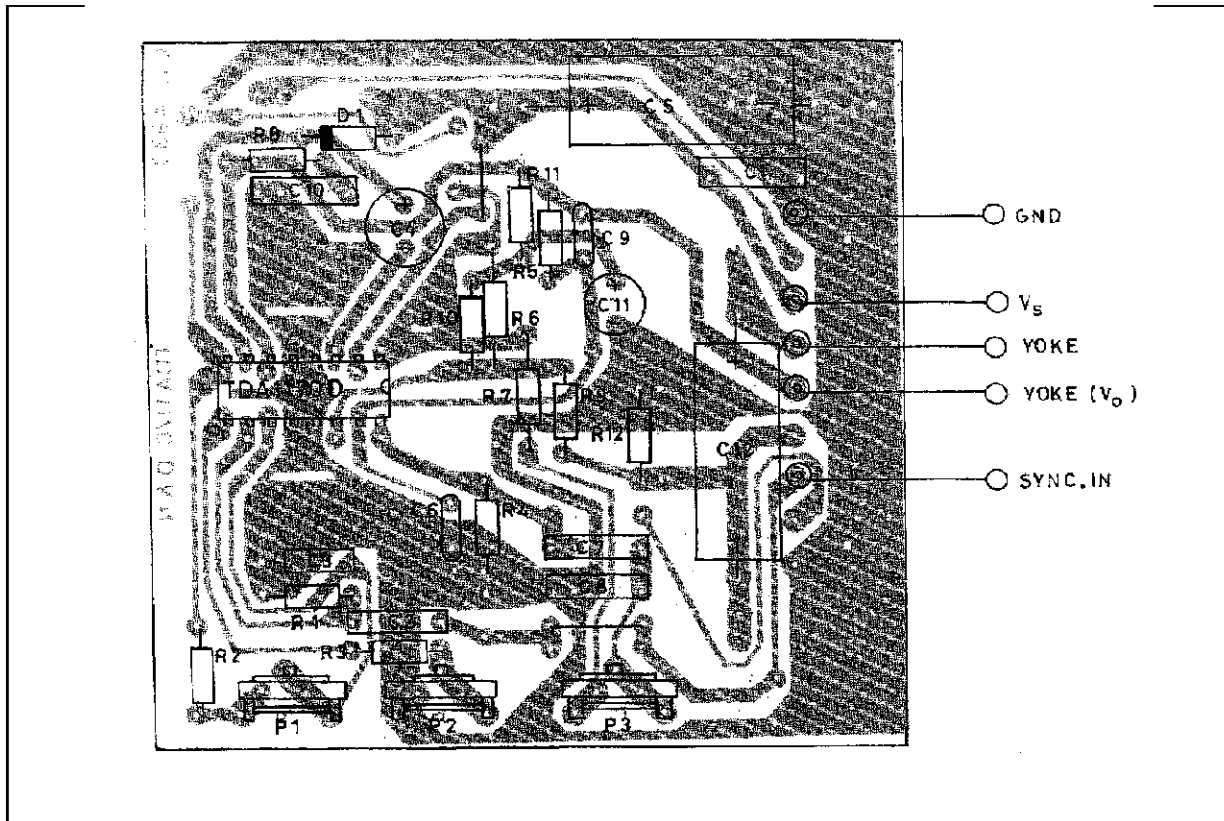


Figure 3 : Typical Application Circuit for Small Screen B/W TV SET ( $R_y = 2.9\Omega$ ,  $L_y = 6mH$ ,  $I_y = 1.1A_{pp}$ )



1170D-08.EPS

Figure 4 : P.C. Board and Components Layout of the Circuit of Fig. 3 (1 : 1 scale)



1170D-09.TIF

**MOUNTING INSTRUCTION**

The  $R_{th\ j-amb}$  of the TDA 1170D can be reduced by soldering the GND pins to a suitable copper area of the printed circuit board (fig. 5) or to an external heatsink (fig. 6).

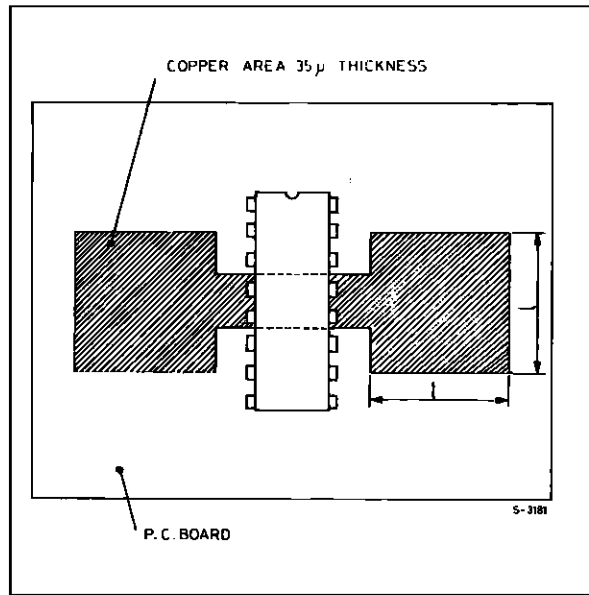
The diagram of figure 7 shows the maximum dissiable power  $P_{tot}$  and the  $R_{th\ j-amb}$  as a function of

the side "l" of two equal square copper areas having a thickness of  $35\ \mu$  (1.4 mils).

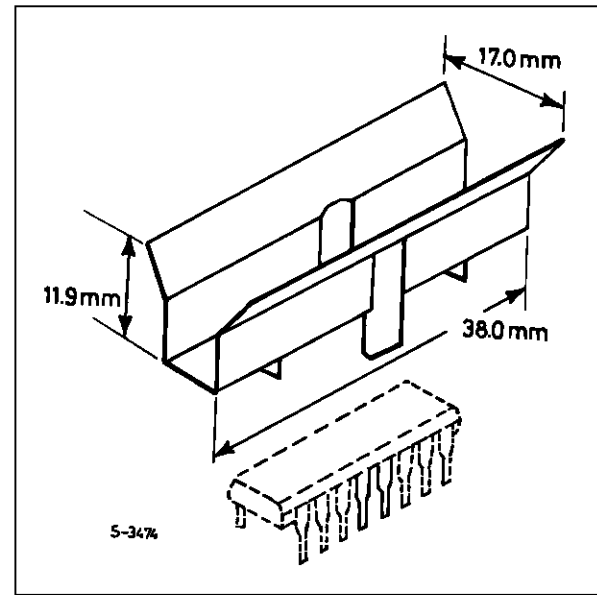
During soldering the pins temperature must not exceed  $260\ ^\circ\text{C}$  and the soldering time must not be longer than 12 seconds.

The external heatsink or printed circuit copper area must be connected to electrical ground.

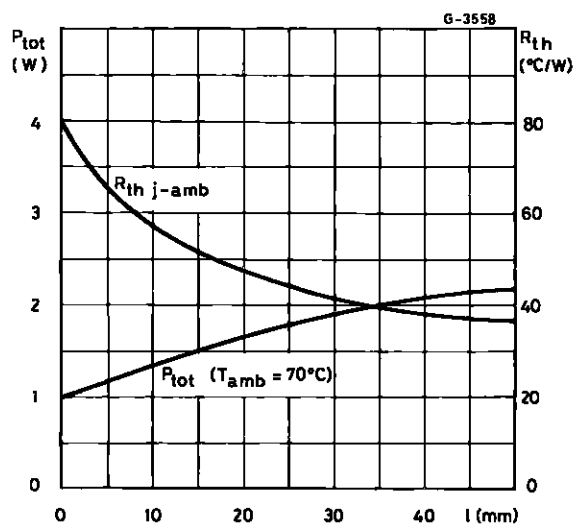
**Figure 5 :** Example of P.C. Board Copper Area which is Used as Heatsink



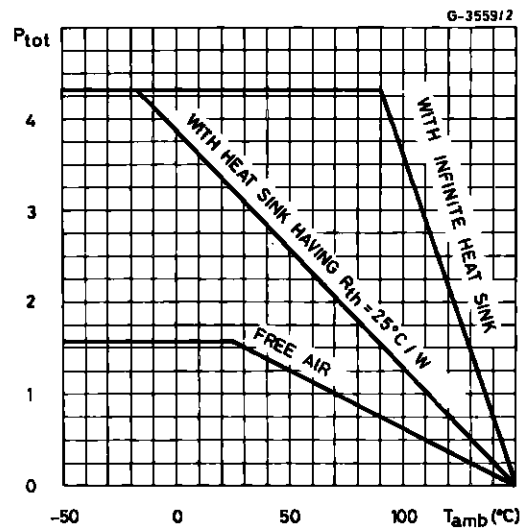
**Figure 6 :** External Heatsink Mounting Example



**Figure 7 :** Maximum Dissiable Power and Junction-Ambient Thermal Resistance versus Side "l"

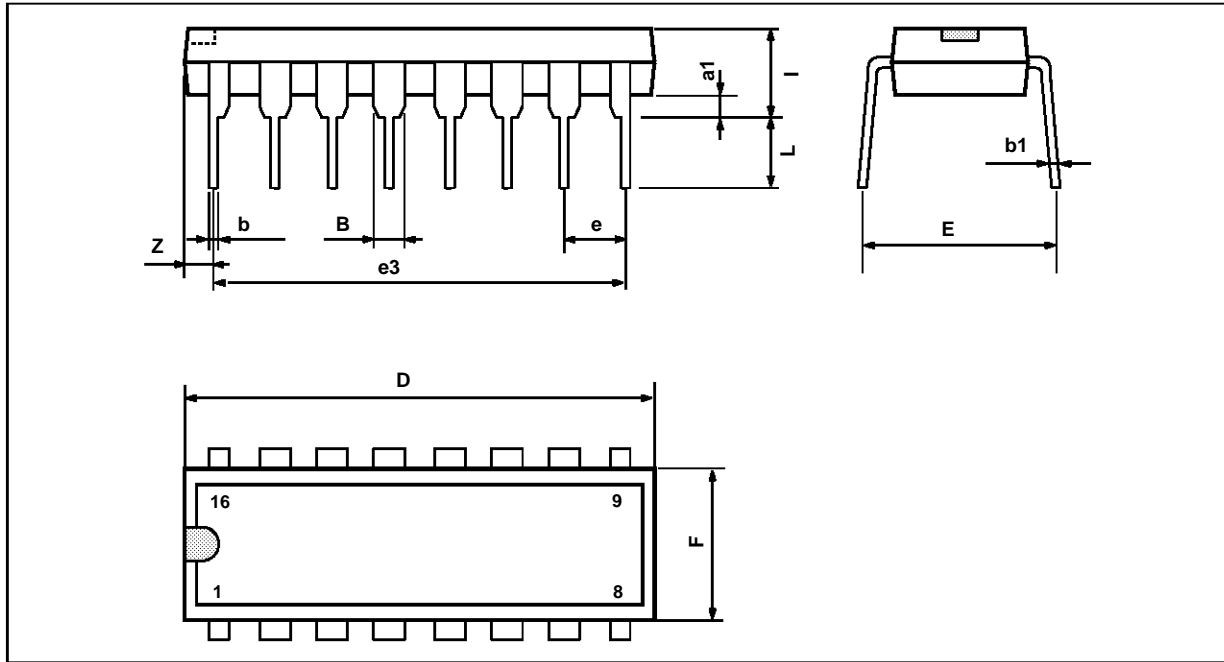


**Figure 8 :** Maximum Allowable Power Dissipation versus Ambient Temperature



# TDA1170D

## PACKAGE MECHANICAL DATA 16 PINS - PLASTIC PACKAGE



PM-DIP16.EPS

| Dimensions | Millimeters |       |      | Inches |       |       |
|------------|-------------|-------|------|--------|-------|-------|
|            | Min.        | Typ.  | Max. | Min.   | Typ.  | Max.  |
| a1         | 0.51        |       |      | 0.020  |       |       |
| B          | 0.77        |       | 1.65 | 0.030  |       | 0.065 |
| b          |             | 0.5   |      |        | 0.020 |       |
| b1         |             | 0.25  |      |        | 0.010 |       |
| D          |             |       | 20   |        |       | 0.787 |
| E          |             | 8.5   |      |        | 0.335 |       |
| e          |             | 2.54  |      |        | 0.100 |       |
| e3         |             | 17.78 |      |        | 0.700 |       |
| F          |             |       | 7.1  |        |       | 0.280 |
| i          |             |       | 5.1  |        |       | 0.201 |
| L          |             | 3.3   |      |        | 0.130 |       |
| Z          |             |       | 1.27 |        |       | 0.050 |

DIP16.TBL

Information furnished is believed to be accurate and reliable. However, SGS-THOMSON Microelectronics assumes no responsibility for the consequences of use of such information nor for any infringement of patents or other rights of third parties which may result from its use. No licence is granted by implication or otherwise under any patent or patent rights of SGS-THOMSON Microelectronics. Specifications mentioned in this publication are subject to change without notice. This publication supersedes and replaces all information previously supplied. SGS-THOMSON Microelectronics products are not authorized for use as critical components in life support devices or systems without express written approval of SGS-THOMSON Microelectronics.

© 1994 SGS-THOMSON Microelectronics - All Rights Reserved

Purchase of I<sup>2</sup>C Components of SGS-THOMSON Microelectronics, conveys a license under the Philips I<sup>2</sup>C Patent. Rights to use these components in a I<sup>2</sup>C system, is granted provided that the system conforms to the I<sup>2</sup>C Standard Specifications as defined by Philips.

SGS-THOMSON Microelectronics GROUP OF COMPANIES

Australia - Brazil - China - France - Germany - Hong Kong - Italy - Japan - Korea - Malaysia - Malta - Morocco  
The Netherlands - Singapore - Spain - Sweden - Switzerland - Taiwan - Thailand - United Kingdom - U.S.A.