

**MULTISTANDARD VIDEO IF AMPLIFIER**

- SWITCHING OFF THE IF AMPLIFIER WHEN OPERATING IN VTR MODE
- DEMODULATION OF NEGATIVE OR POSITIVE IF SIGNALS. THE OUTPUT REMAINS ON THE SAME POLARITY IN EVERY CASE
- IF AGC AUTOMATICALLY ADJUSTED TO THE ACTUAL STANDARD
- TWO AGC POSSIBILITIES FOR B/G MODE :
  1. GATED AGC
  2. UNGATED AGC ON SYNC. LEVEL AND CONTROLLED DISCHARGE DEPENDENT ON THE AVERAGE SIGNAL LEVEL FOR VTR AND PERI TV APPLICATIONS
- FOR STANDARD L : FAST AGC ON PEAK WHITE BY CONTROLLED DISCHARGE
- POSITIVE OR NEGATIVE GATING PULSE
- EXTREMELY HIGH INPUT SENSITIVITY
- LOW DIFFERENTIAL DISTORTION
- CONSTANT INPUT IMPEDANCE
- VERY HIGH SUPPLY VOLTAGE REJECTION
- FEW EXTERNAL COMPONENTS
- LOW IMPEDANCE VIDEO OUTPUT
- SMALL TOLERANCES OF THE FIXED VIDEO SIGNAL AMPLITUDE
- ADJUSTABLE, DELAYED AGC FOR PNP TUNERS

**DESCRIPTION**

The TDA4443 is a Video IF amplifier with standard switch for multistandard colour or monochrome TV sets, and VTR's.

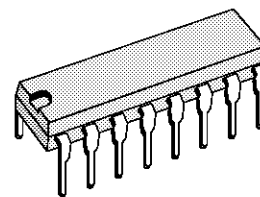

**DIP16**  
(Plastic Package)

**ORDER CODE : TDA4443**

**PIN CONNECTIONS**

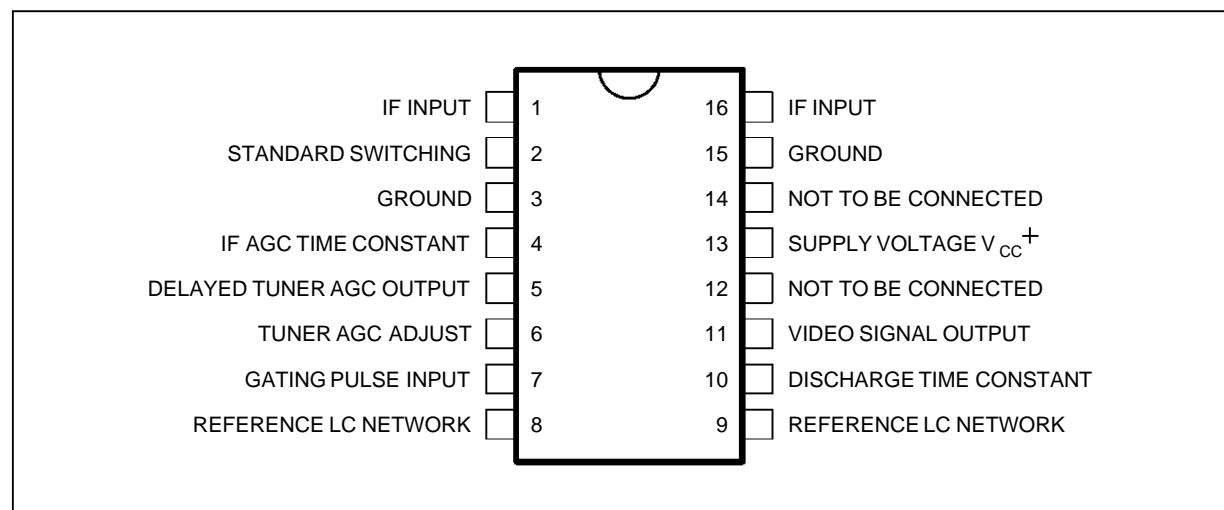

4443-01.EPS

BLOCK DIAGRAM

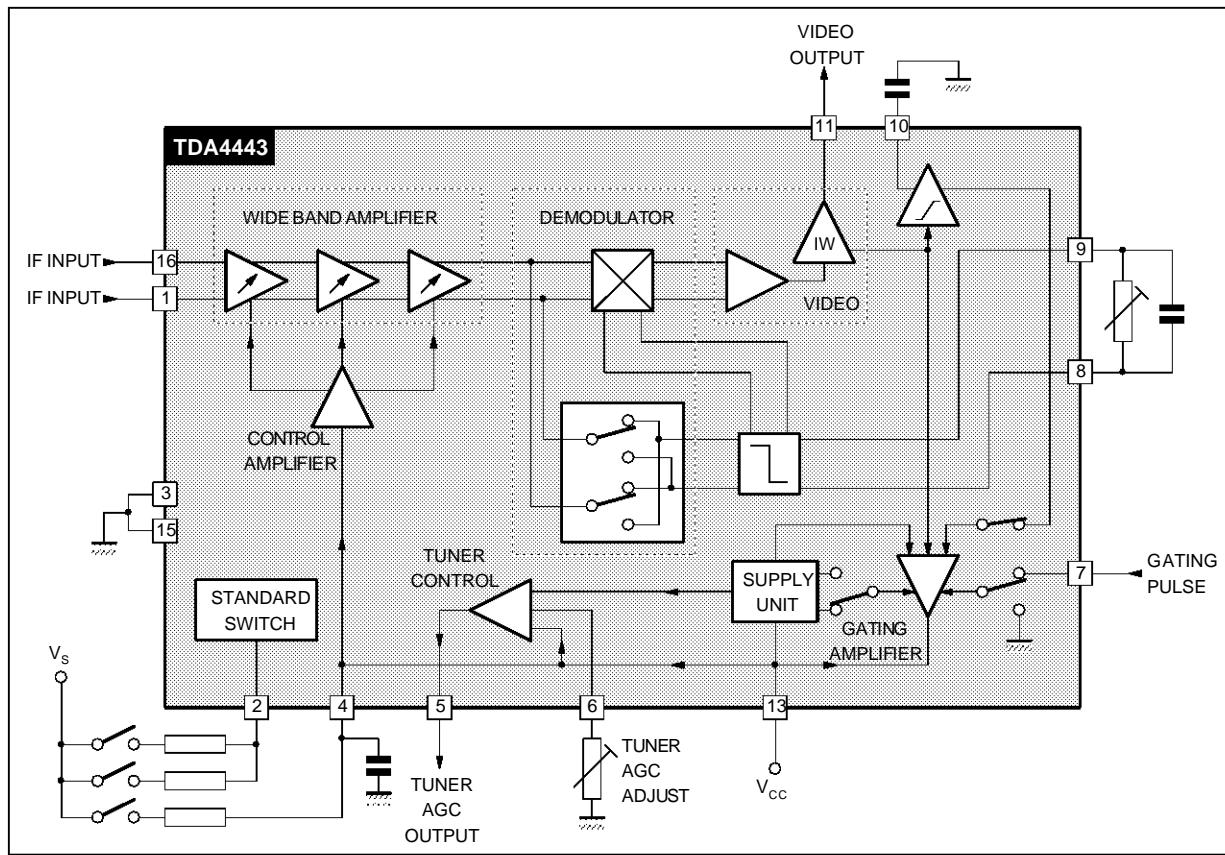

GENERAL DESCRIPTION

This video IF processing circuit integrates the following functional blocks :

- Three symmetrical, very stable, gain controlled wideband amplifier stages - without feedback by a quasi-galvanic coupling.
- Demodulator controlled by the picture carrier
- Video output amplifier with high supply voltage

rejection

- Polarity switch for the video output signal
- AGC on peak white level
- Gated AGC
- Discharge control
- Delayed tuner AGC
- At VTR Reading mode the video output signal is at ultra white level

## ABSOLUTE MAXIMUM RATINGS

Symbol	Parameter	Value	Unit
V <sub>CC</sub>	Supply Voltage Range Pin 13	15	V
V <sub>0</sub>	Open Loop Voltage Pin 5	max. V <sub>CC</sub>	V
V <sub>ext</sub>	External Voltage Pin 4	12	V
I <sub>4</sub>	Control Current for VTR Mode Pin 4	0.3	mA
I <sub>2</sub>	Control Current for Standard Mode Pin 2	0.5	mA
I <sub>0</sub>	Max. Video Output Current Pin 11	5	mA
I <sub>0</sub>	Short Circuit Current (t ≤ 1sec) Pin 11	30	mA
P <sub>tot</sub>	Power Dissipation	1	W
T <sub>j</sub>	Junction Temperature	125	°C
T <sub>AMB</sub>	Ambient Temperature Range	0 to +70	°C
T <sub>stg</sub>	Storage Temperature Range	-25 to +125	°C

4443-01.TBL

## THERMAL DATA

Symbol	Parameter	Value	Unit
R <sub>th(j-a)</sub>	Junction-ambient Thermal Resistance	70	°C/W

4443-02.TBL

## ELECTRICAL OPERATING CHARACTERISTICS

T<sub>AMB</sub> = 25°C, V<sub>CC</sub> = 12V, unless otherwise specified. Test Circuit Page 5.

Symbol	Parameter	Pin	Min.	Typ.	Max.	Unit
V <sub>CC</sub>	Supply Voltage	13	10	12	15	V
I <sub>CC</sub>	Supply Current (V <sub>CC</sub> = 12V, V <sub>4</sub> = 3.5V, V <sub>IN</sub> = 0) Pin 6, Pin 7, Pin 2 open	13		55	75	mA
V <sub>11</sub>	Ultra White Level at Standard B/G V <sub>CC</sub> = 15V, V <sub>4</sub> = 3.5V	11	4.8	5.1	5.6	V
V <sub>AA</sub>	Ultra Black Clamping Level at Standard B/G SIGNAL 1	11	1.70	1.85	2.10	V
V <sub>O</sub>	Picture to sync. output voltage of the video signal without load in standard B/G (residual carrier 10%) SIGNAL 1	11	2.6	2.9	3.3	V <sub>PP</sub>
V <sub>O</sub>	Picture to blanking level output voltage of the video signal without load in standard L (blanking level at 28% of carrier amplitude) SIGNAL 2 (residual carrier 5%)	11	1.80	2.1	2.40	V <sub>PP</sub>
$\frac{\Delta(V_p - V_{blank})}{V_p - V_{blank}}$	Output voltage change of the picture to blanking level from standard L to standard B/G (mode BG : signal 1, mode L : signal 2)	11			10	%
ΔV <sub>black</sub>	Supply voltage influence on the ultra black level in standard B/G	11		0.5		%V
ΔV <sub>white</sub>	Supply voltage influence on the ultra white level in standard B/G	11		1		%V
ΔV <sub>video</sub>	Video Bandwidth Video Signal Attenuation with V <sub>IN</sub> at 4.43MHz	11		1	1.5	dB
B <sub>video</sub>	Video Bandwidth at -3dB	11	6			MHz
ΔV <sub>video</sub>	Video frequency response changes within the AGC range	11		0.5	2.0	dB
I <sub>0</sub>	DC Output Current (V <sub>11</sub> = 10V, V <sub>CC</sub> = 15V)	11		1.5	2	mA
I <sub>7</sub>	Gating Pulse Current	7	0.30		1.0	mA
V <sub>7</sub>	DC Voltage at Gating Input	7		1.3	1.6	V
V <sub>1</sub>	Input Voltage Sensitivity V <sub>IN</sub> (with V <sub>OUT</sub> = V <sub>O</sub> - 3dB) Standard B/G SIGNAL 1	1-16		120		μV <sub>RMS</sub>
I	Control Current for Status B (see status of mode switching) V <sub>2</sub> = 5V	2		10	40	μA

4443-03.TBL

# TDA4443

## ELECTRICAL OPERATING CHARACTERISTICS (continued)

T<sub>AMB</sub> = 25°C, V<sub>CC</sub> = 12V, unless otherwise specified. Test Circuit Page 5.

Symbol	Parameter	Pin	Min.	Typ.	Max.	Unit
I	Control Current Status C (see status of mode switching) - V <sub>2</sub> = 6.3V	2		60	400	μA
ΔG <sub>IF</sub>	IF AGC Range			60		dB
I <sub>AGC</sub>	Available Tuner AGC Current (10dB above the AGC starting point)	5	8	12		mA
ΔAGC	Delay Between Tuner AGC and IF AGC (pin 6 not connected)	5		50		dB
V <sub>IF</sub> V <sub>2IF</sub>	IF residual carrier at the video o/p withing the AGC range 38.9MHz 77.8MHz	11 11		20 50		mV <sub>RMS</sub> mV <sub>RMS</sub>
d	Differential Distortion on Composite Video Signal Amplitude SIGNAL 3	11			5	%
aM	Attenuation of sound to color carrier intermodulation signal (1.07MHz) referred to the demodulated color carrier : Picture Carrier = 0dB, Color Carrier = -6dB, Sound Carrier = -24dB	11		50		dB
$\frac{\Delta \text{Sync}}{\text{Sync}}$	Sync. Pulse Compression within the IF AGC Range			3		%
RI CI	Input Impedance : Resistance Capacitance	1-16 1-16		2.5 2		kΩ pF
V	Switch off Control Voltage for VTR Mode	4	9		10	V
I	Switch off Current for VTR Mode	4			150	μA

4443-04.TBL

## SIGNAL 1 (standard B/G)

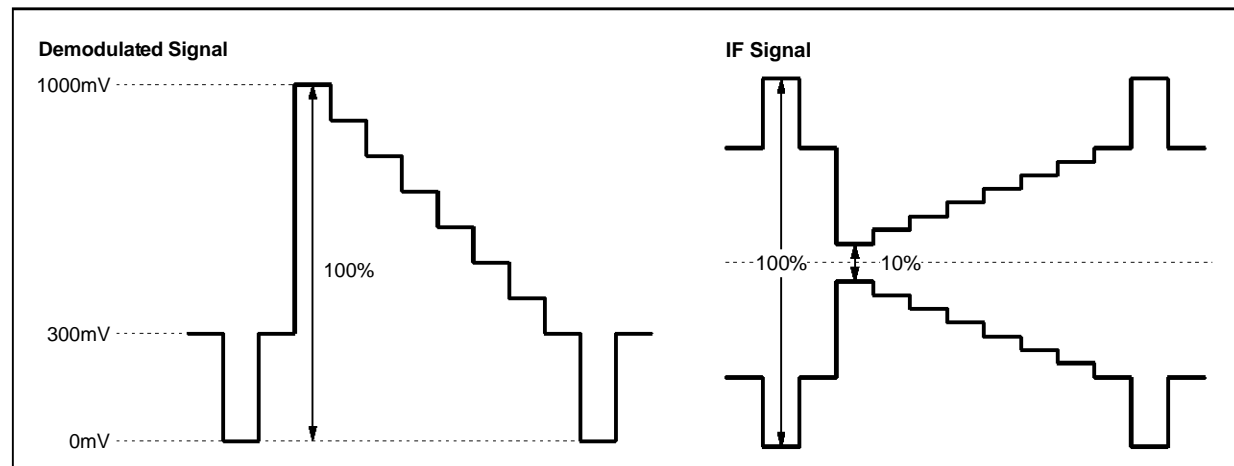

4443-03.EPS / 4443-04.EPS

**SIGNAL 2 (standard L)**

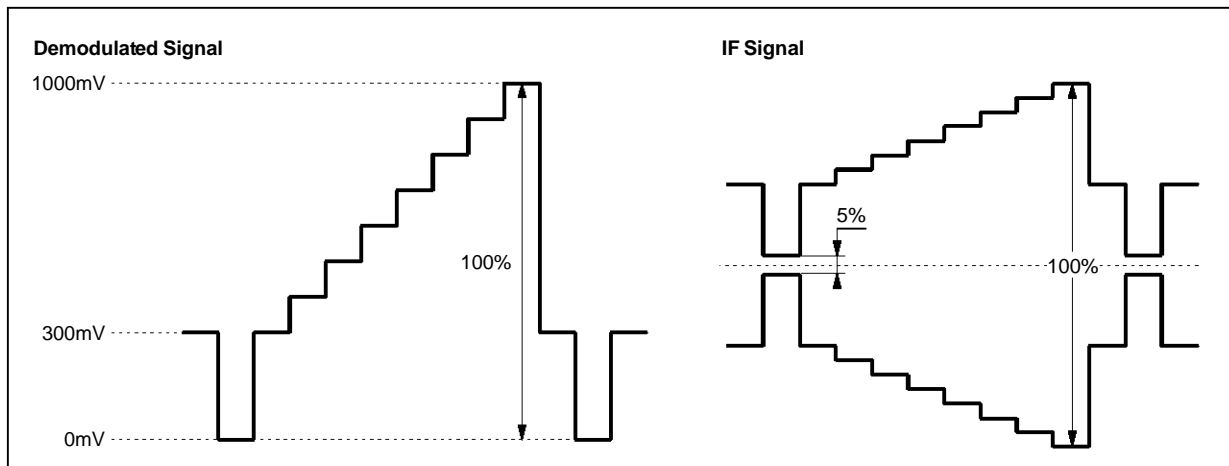

**SIGNAL 3**

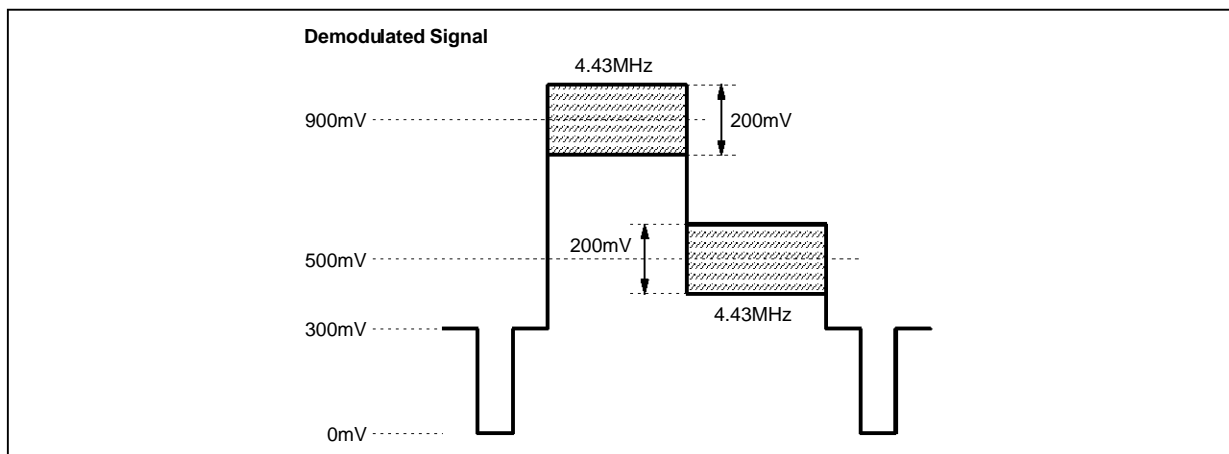

**TEST CIRCUIT**

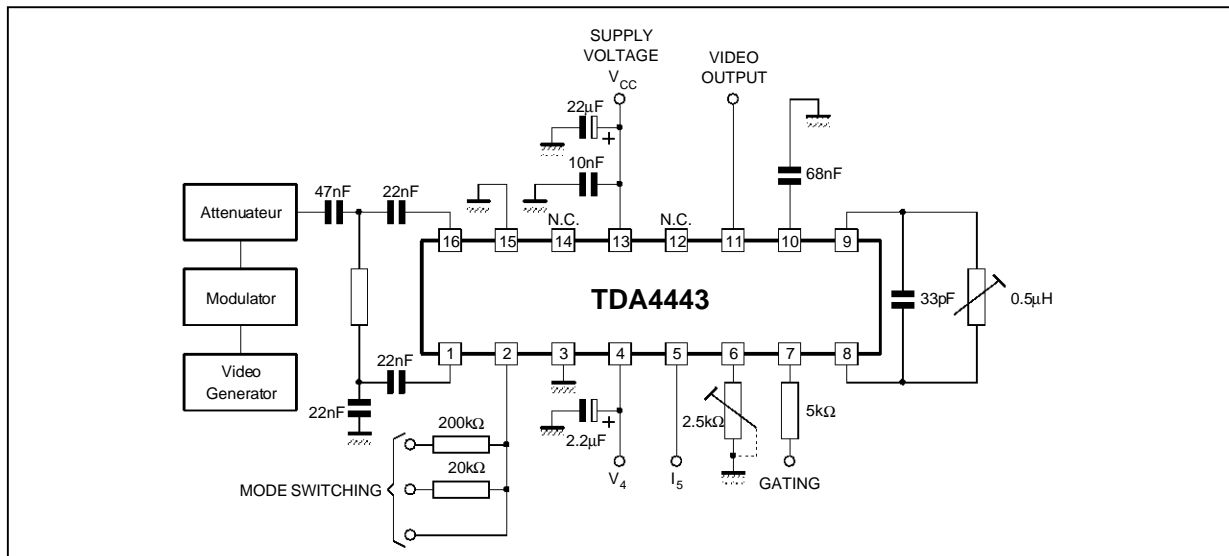

**DEFINITION OF MODE SWITCHING**

Status	Pin 2	Pin 4	Function
A	Not connected	No External Voltage	Standard B/G mode, gated charge and discharge.
B	12V High Impedance	No External Voltage	Standard B/G, ungated, charging up to sync. level, discharging dependant from average signal (peri operation).
C	12V Low Impedance	No External Voltage	At standard L ungated, charging up to peak white level, discharge dependant from average signal level, inverted polarity of the video output.
D	No specifications	≥ 7.5V	In VTR reading mode the IF amplifier is blocked, turned gain controlled down : the video output signal is fixed at constant ultra white level for standard B/G mode.

4443-05.TBL

The gating pulse at Pin 7 is internally switched off.

**STATUS OF MODE SWITCHING, REFERRING TO CONTROL VOLTAGE PIN 2**

Control Voltage Pin 2	Connections of Pin 2	Status	Function
1.2 to 2.5V*	Open	A	Standard B/G gated sync. operation
3.0 to 5.0V	High Impedance	B	Standard B/G, no sync., operation
> 6.5V	Low Impedance	C	Standard L
0.0 to 0.8V	Ground	D	Standard L

4443-06.TBL

\* Voltage measured on Pin 2.

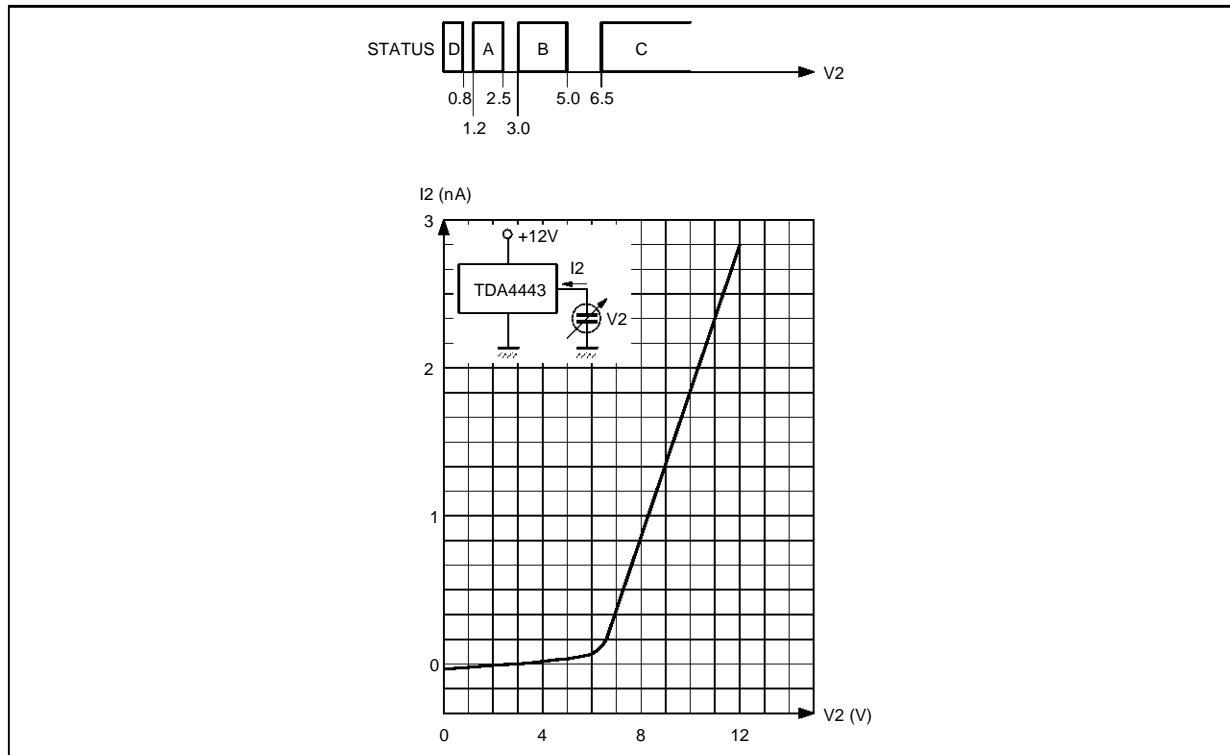

4443-09.EPS

## PACKAGE MECHANICAL DATA

16 PINS - PLASTIC DIP

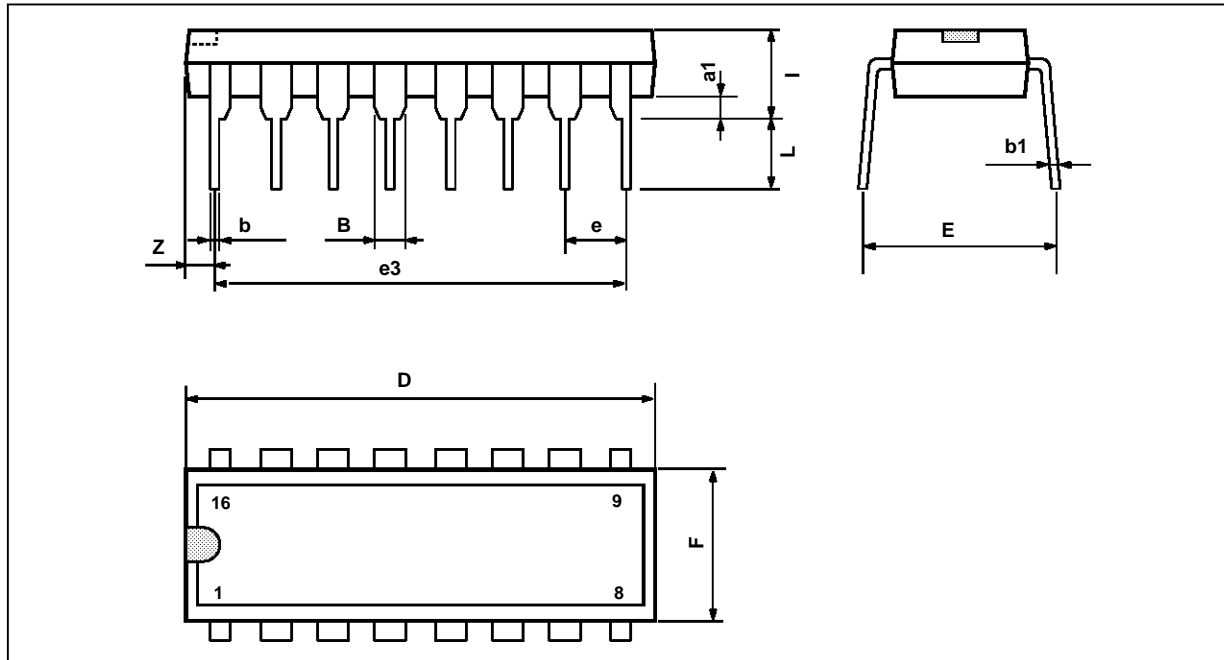

PM-DIP16.EPS

Dimensions	Millimeters			Inches		
	Min.	Typ.	Max.	Min.	Typ.	Max.
a1	0.51			0.020		
B	0.77		1.65	0.030		0.065
b		0.5			0.020	
b1		0.25			0.010	
D			20			0.787
E		8.5			0.335	
e		2.54			0.100	
e3		17.78			0.700	
F			7.1			0.280
i			5.1			0.201
L		3.3			0.130	
Z			1.27			0.050

DIP16.TBL

Information furnished is believed to be accurate and reliable. However, SGS-THOMSON Microelectronics assumes no responsibility for the consequences of use of such information nor for any infringement of patents or other rights of third parties which may result from its use. No licence is granted by implication or otherwise under any patent or patent rights of SGS-THOMSON Microelectronics. Specifications mentioned in this publication are subject to change without notice. This publication supersedes and replaces all information previously supplied. SGS-THOMSON Microelectronics products are not authorized for use as critical components in life support devices or systems without express written approval of SGS-THOMSON Microelectronics.

© 1994 SGS-THOMSON Microelectronics - All Rights Reserved

Purchase of I<sup>2</sup>C Components of SGS-THOMSON Microelectronics, conveys a license under the Philips I<sup>2</sup>C Patent. Rights to use these components in a I<sup>2</sup>C system, is granted provided that the system conforms to the I<sup>2</sup>C Standard Specifications as defined by Philips.

SGS-THOMSON Microelectronics GROUP OF COMPANIES

Australia - Brazil - China - France - Germany - Hong Kong - Italy - Japan - Korea - Malaysia - Malta - Morocco  
The Netherlands - Singapore - Spain - Sweden - Switzerland - Taiwan - Thailand - United Kingdom - U.S.A.