

**PROXIMITY DETECTOR**

- SUPPLY VOLTAGE : +4 TO +36V
- SUPPLY CURRENT : < 1.2mA
- OUTPUT TRANSISTORS : I = 20mA;  
V<sub>CE (sat)</sub> ≤ 1100mV
- OSCILLATOR FREQUENCY : < 1MHz
- LOSS RESISTANCE : 5 TO 50kΩ.

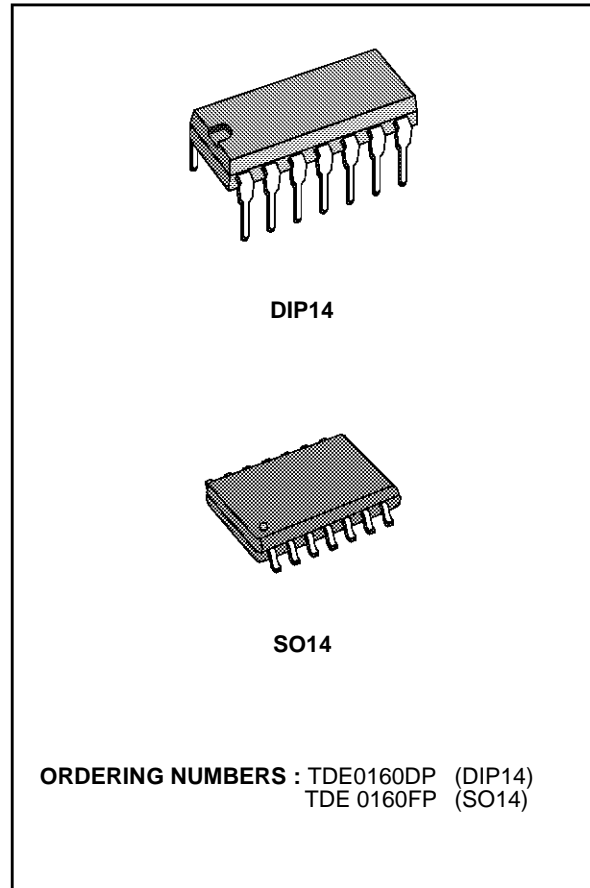

**DESCRIPTION**

The TDE0160 is designed to detect metal bodies by the effect of Eddy currents on the HF losses of a coil. It has two complementary open collector outputs with peak limiting. Hysteresis is adjustable, and an electronic switching circuit is incorporated for disabling both outputs.

An internal zener diode maintains the supply voltage to the circuit in "dipole" operation.

**PIN CONNECTION (top view)**

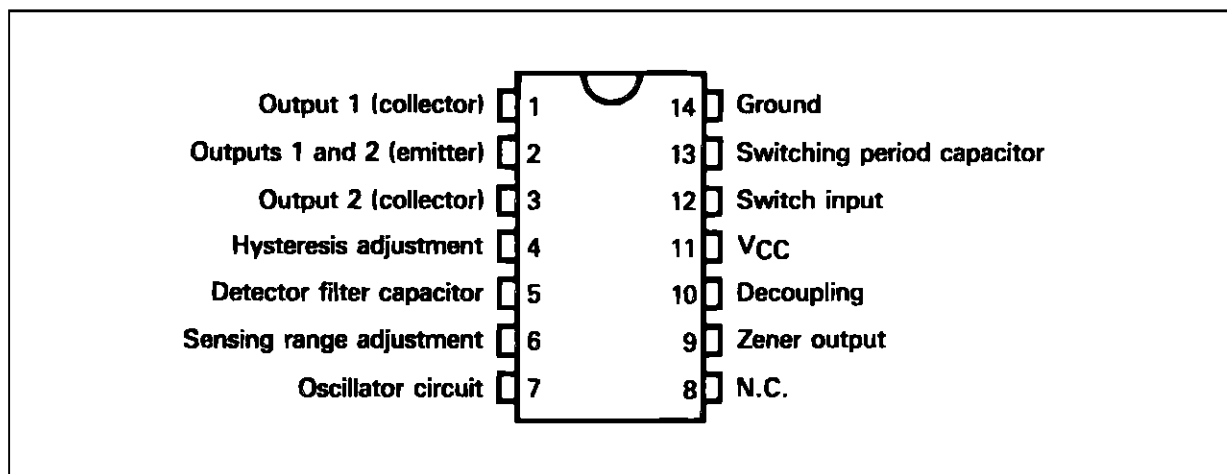

SCHEMATIC DIAGRAM

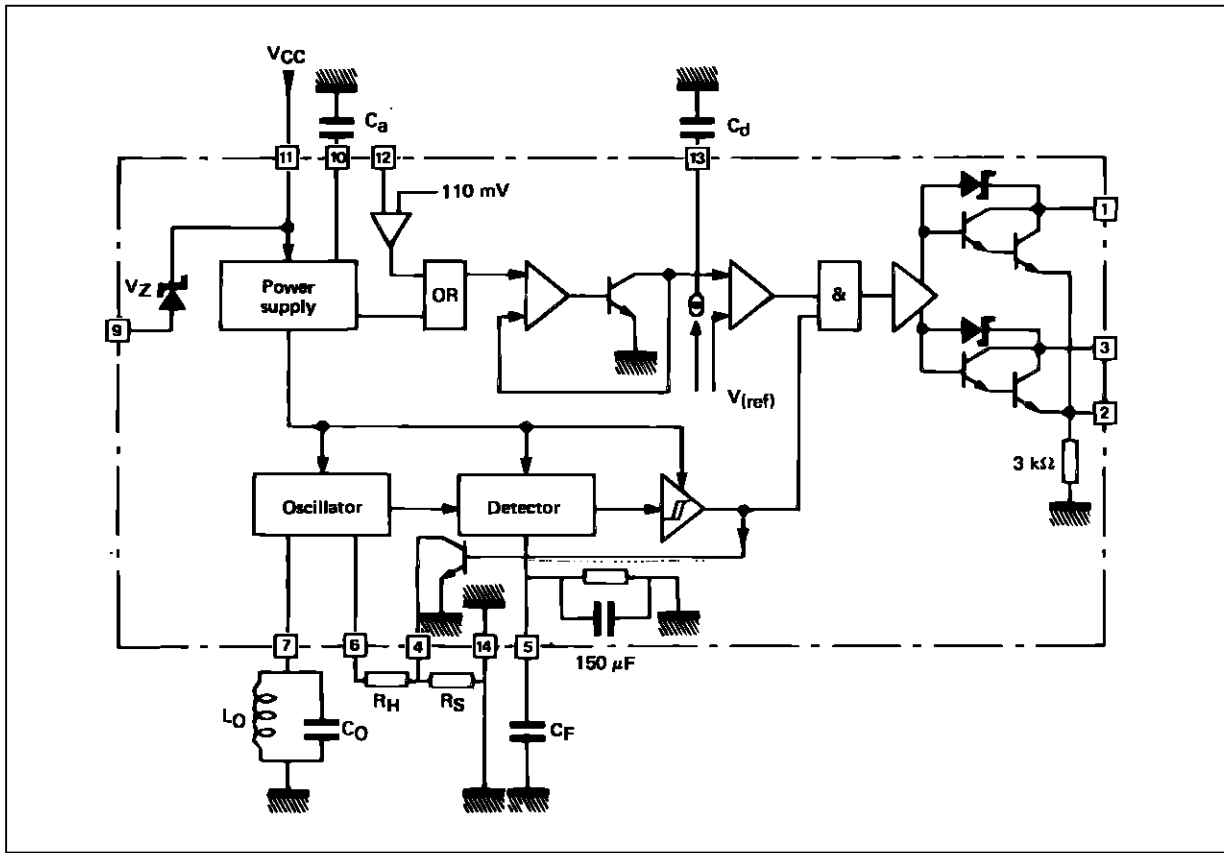

ABSOLUTE MAXIMUM RATINGS

Symbol	Parameter	Value	Unit
V <sub>cc</sub>	Supply Voltage	36	V
V <sub>O*</sub>	Output Voltage*	36	V
I <sub>O</sub> (I <sub>1</sub> -I <sub>3</sub> )	Output Current (I <sub>1</sub> -I <sub>3</sub> )	40	mA
I <sub>Z</sub>	Zener Current	40	mA
T <sub>J</sub>	Junction Temperature	+ 150	°C
T <sub>oper</sub>	Ambient Temperature Range	- 25 to + 85	°C
T <sub>stg</sub>	Storage Temperature Range	- 65 to + 150	°C

\* Internal peak limiting to protect against transient voltage surges.

## ELECTRICAL CHARACTERISTICS

$T_{amb} = +25^{\circ}\text{C}$  unless otherwise specified

Symbol	Parameter	Min.	Typ.	Max.	Unit
$V_{CC}$	Supply Voltage Pin 11	4		36	V
$V_Z$	Zener Voltage ( $I_Z = 20\text{mA}$ ) Pins 9-11	3		4	V
$I_{CC}$	Supply Current Pin 11			1.2	mA
–	Limiting ( $I = 0.1\text{mA}$ ) Pin 1 or 3		42		V
–	Output Transistor Saturation Voltage ( $I_1$ or $I_3 = +20\text{mA}$ ) Pin 1 or 3		0.9	1.1	V
–	Output Transistor Leakage Current ( $V = +30\text{V}$ ) Pin 1 or 3			2	$\mu\text{A}$
–	Switching Threshold Pin 12	90	110	130	mV
$R_n$	Negative Resistance* ( $5\text{k}\Omega < R_H < 50\text{k}\Omega$ , $f = 100\text{kHz}$ , $R_S = 0$ )		$R_n = R_H$		
–	Inherent Hysteresis ( $R_2 = 0$ )		1	2	%
–	Programmed Hysteresis ( $H < 15\%$ )		$\frac{R_S}{R_S + R_H}$		%
$f_{osc}$	Oscillation Frequency			1	MHz
–	Switching Frequency (with matched oscillator circuit)		750		Hz
–	Switching Time-delay		$0.5 C_d$ ( $\mu\text{F}$ )		s
–	Switching Response Time ( $C_d = 10\text{nF}$ ; $V_{CC} = +20\text{V}$ )		10		$\mu\text{s}$

\* See characteristic curves

## SWITCHING OPERATION

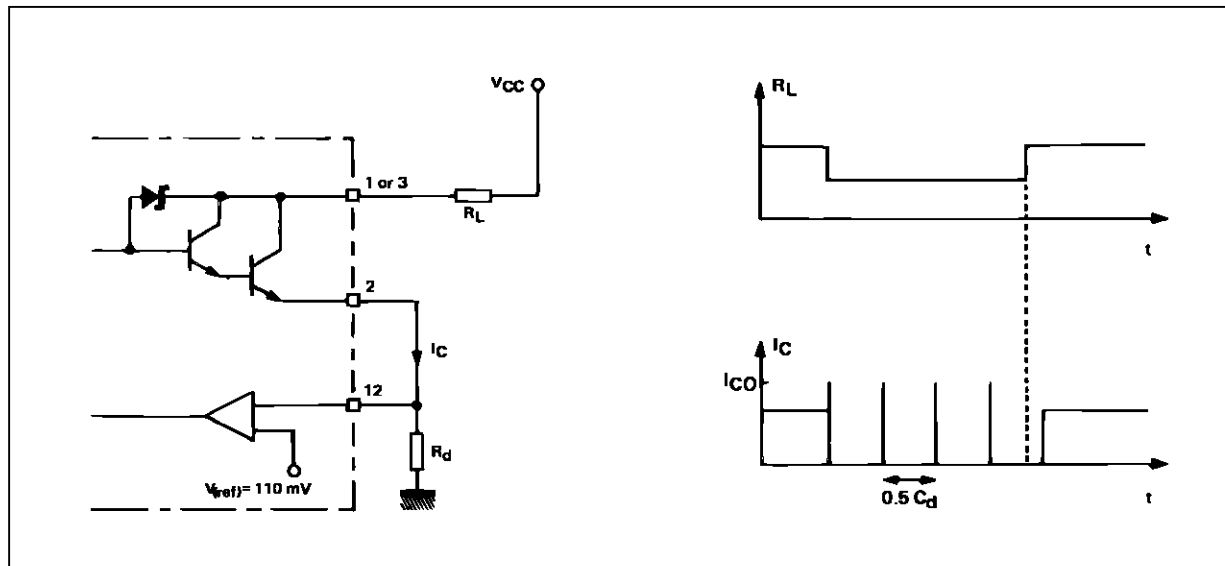

If  $I_C$  exceeds  $I_{CO}$ , where  $I_{CO} = \frac{V_{(ref)}}{R_d}$  the switch cuts off the output transistors and tests the value of current  $I_C$ , with time constant  $0.5 C_d$ .

On power up the internal start system cuts off the output transistors until  $V_{CC}$  reaches a value permitting normal operation of the circuit.

**NEGATIVE RESISTANCE  
vs  
FREQUENCY**

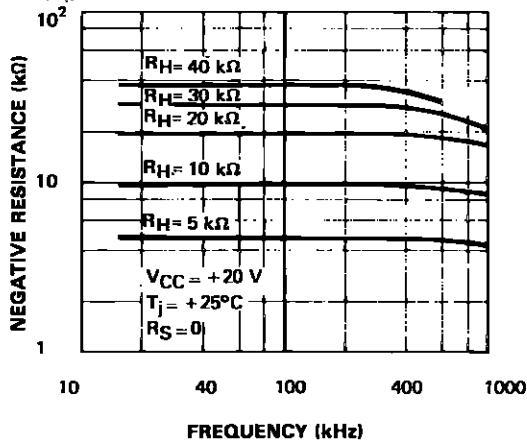

**ZENER VOLTAGE  
vs  
JUNCTION TEMPERATURE**

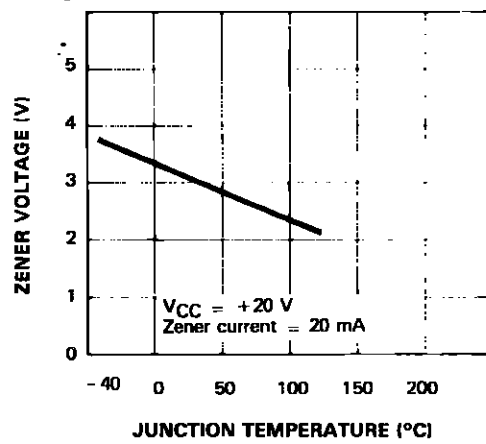

**SWITCHING THRESHOLD  
vs  
JUNCTION TEMPERATURE**

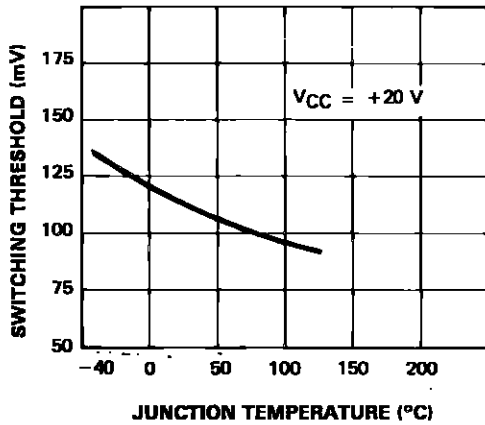

**NEGATIVE RESISTANCE  
vs  
JUNCTION TEMPERATURE**

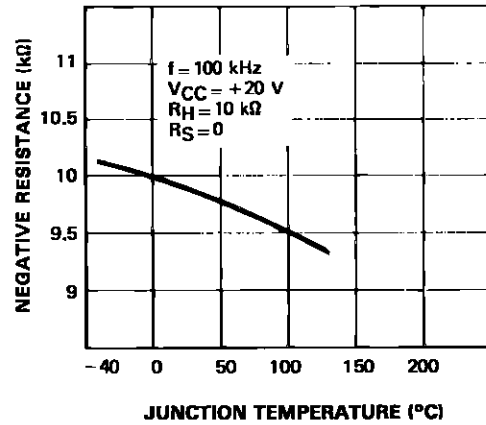

**LOSS RESISTANCE  
vs  
DETECTION RANGE (mm)**

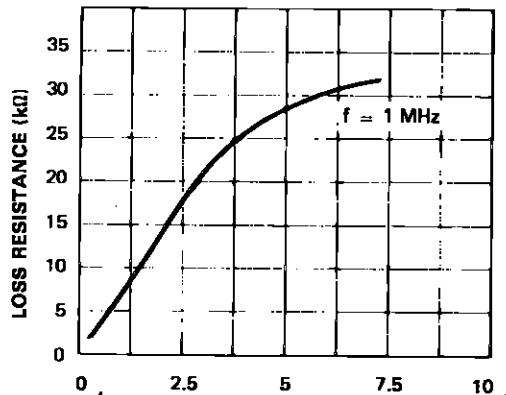

**MILD STEEL**

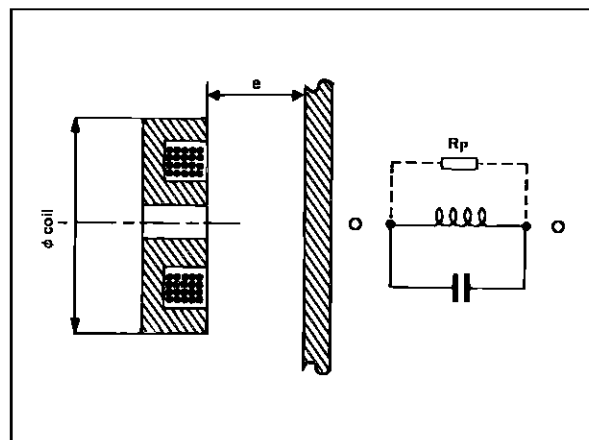

TYPICAL APPLICATION DIAGRAMS

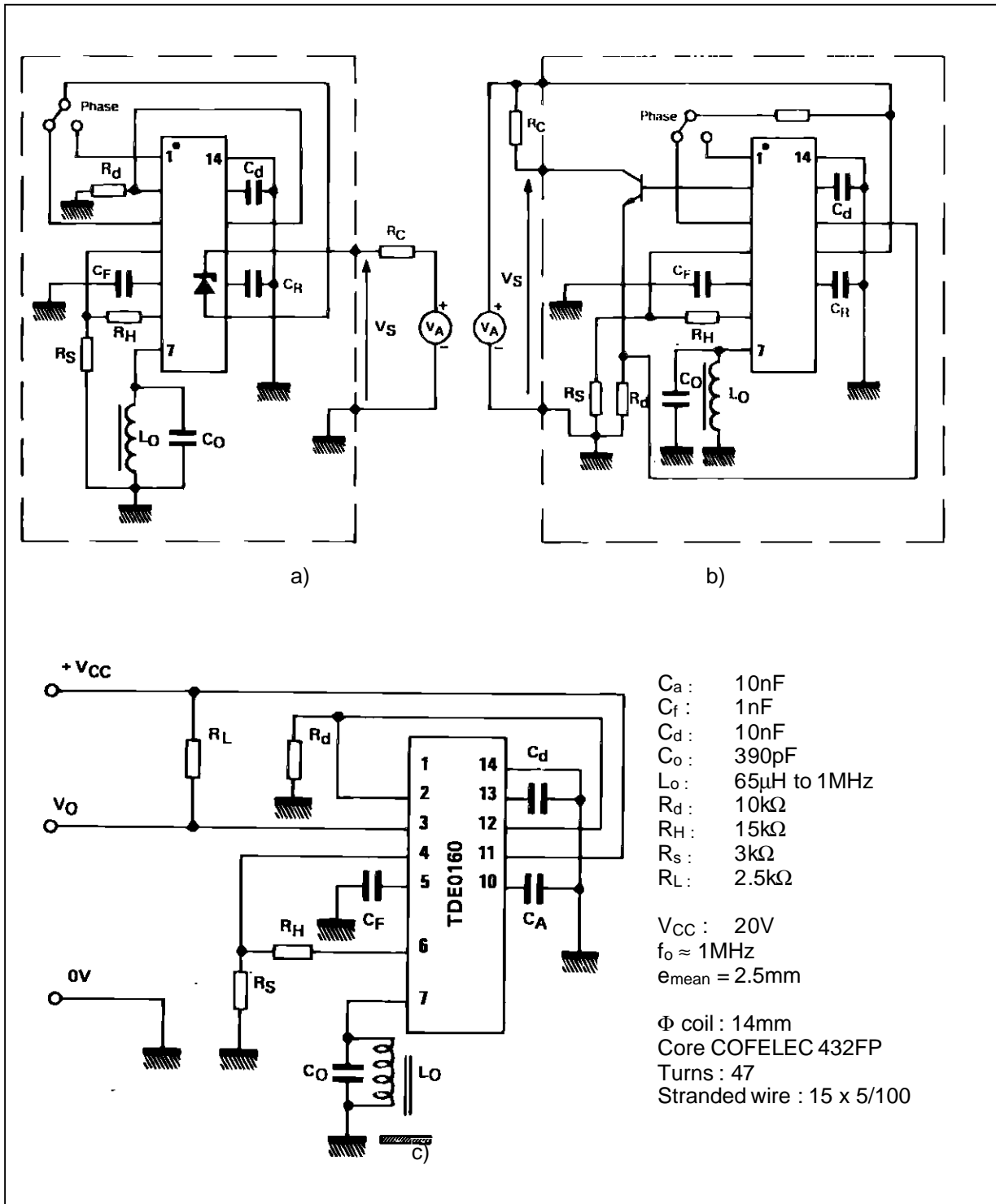

SO14 PACKAGE MECHANICAL DATA

DIM.	mm			inch		
	MIN.	TYP.	MAX.	MIN.	TYP.	MAX.
A			1.75			0.069
a1	0.1		0.25	0.004		0.009
a2			1.6			0.063
b	0.35		0.46	0.014		0.018
b1	0.19		0.25	0.007		0.010
C		0.5			0.020	
c1	45 (typ.)					
D	8.55		8.75	0.336		0.344
E	5.8		6.2	0.228		0.244
e		1.27			0.050	
e3		7.62			0.300	
F	3.8		4.0	0.15		0.157
L	0.4		1.27	0.016		0.050
M			0.68			0.027
S	8 (max.)					

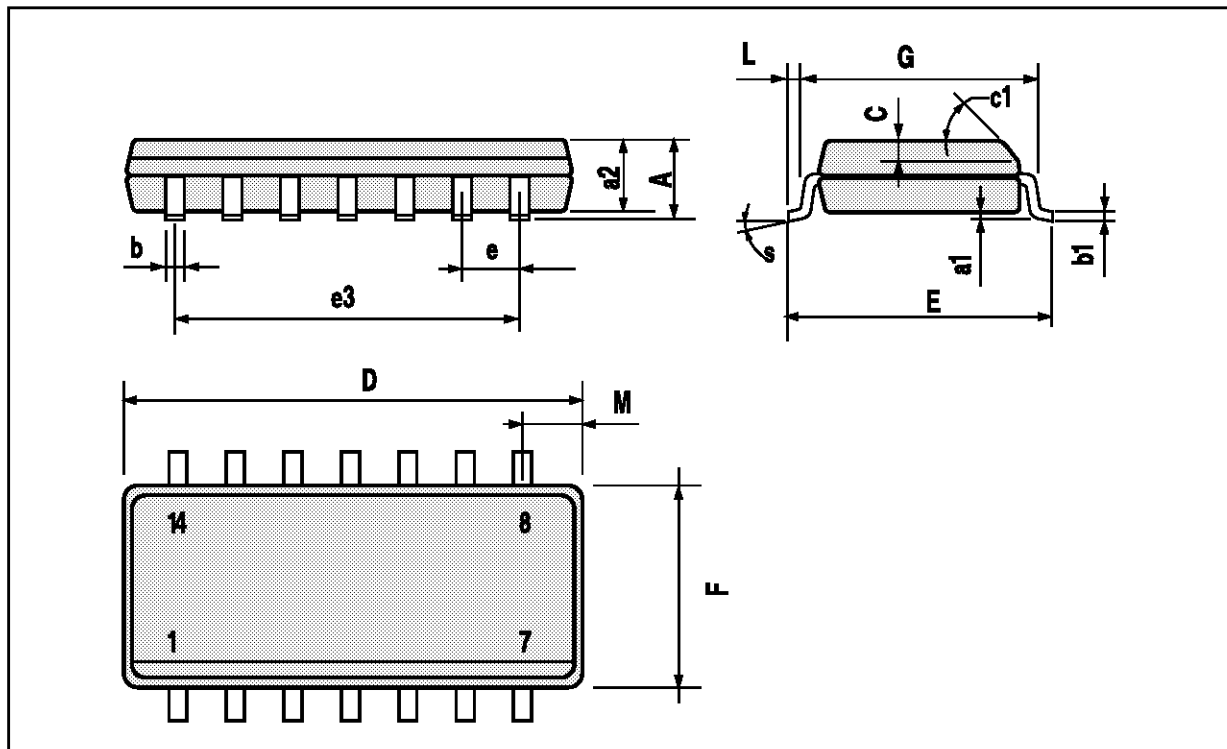

## DIP14 PACKAGE MECHANICAL DATA

DIM.	mm			inch		
	MIN.	TYP.	MAX.	MIN.	TYP.	MAX.
a1	0.51			0.020		
B	1.39		1.65	0.055		0.065
b		0.5			0.020	
b1		0.25			0.010	
D			20			0.787
E		8.5			0.335	
e		2.54			0.100	
e3		15.24			0.600	
F			7.1			0.280
I			5.1			0.201
L		3.3			0.130	
Z	1.27		2.54	0.050		0.100

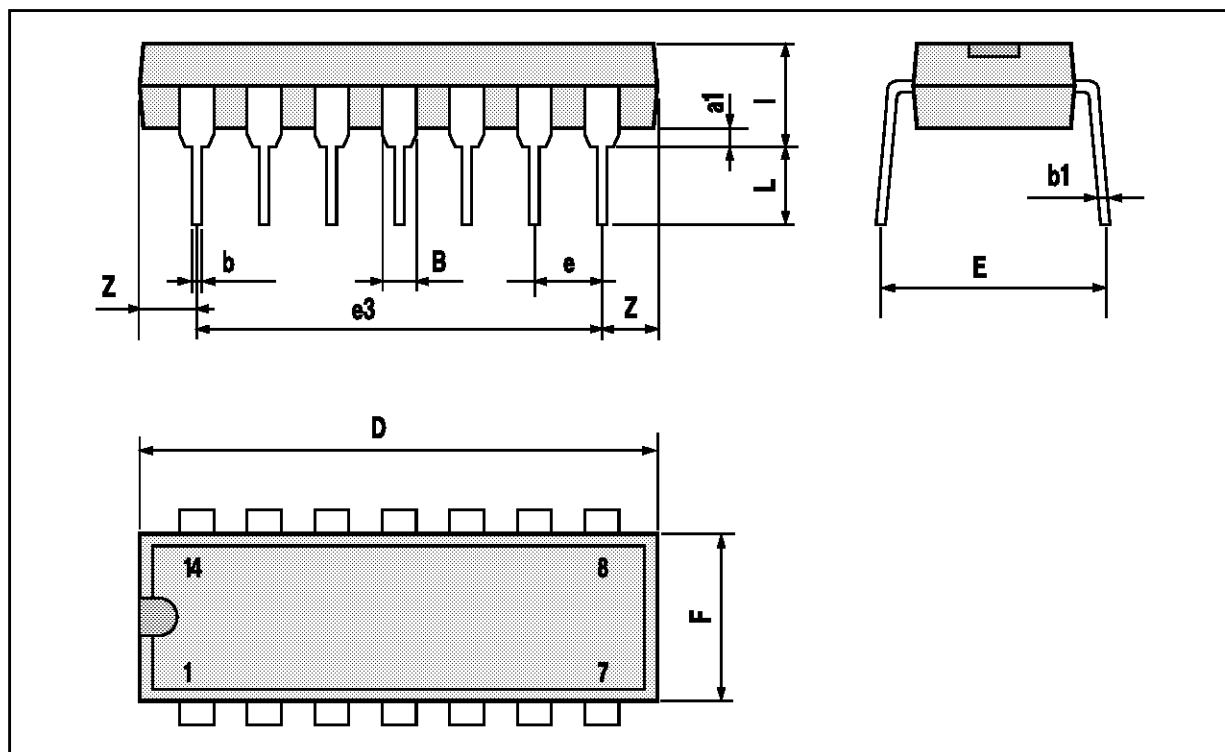

Information furnished is believed to be accurate and reliable. However, SGS-THOMSON Microelectronics assumes no responsibility for the consequences of use of such information nor for any infringement of patents or other rights of third parties which may result from its use. No license is granted by implication or otherwise under any patent or patent rights of SGS-THOMSON Microelectronics. Specifications mentioned in this publication are subject to change without notice. This publication supersedes and replaces all information previously supplied. SGS-THOMSON Microelectronics products are not authorized for use as critical components in life support devices or systems without express written approval of SGS-THOMSON Microelectronics.

© 1994 SGS-THOMSON Microelectronics - All Rights Reserved

SGS-THOMSON Microelectronics GROUP OF COMPANIES

Australia - Brazil - France - Germany - Hong Kong - Italy - Japan - Korea - Malaysia - Malta - Morocco - The Netherlands - Singapore - Spain - Sweden - Switzerland - Taiwan - Thailand - United Kingdom - U.S.A.