

High-Voltage Switchmode Controllers with MOSFET

Ordering Information

$+V_{IN}$		Feedback Voltage	Max Duty Cycle	MOSFET Switch		Package Options	
Min	Max			BV_{DSS}	$R_{DS(ON)}$	14 Pin Plastic DIP	20 Pin Plastic PLCC
10V	70V	$\pm 1.0\%$	49%	150V	5.0 Ω	HV9100P	HV9100PJ
10V	120V	$\pm 1.0\%$	49%	200V	7.0 Ω	HV9102P	HV9102PJ
10V	120V	$\pm 1.0\%$	99%	200V	7.0 Ω	HV9103P	HV9103PJ

Standard temperature range for all parts is industrial (-40° to +85°C).

Features

- 10 to 120V input range
- 200V, 7.0 Ω output MOSFET
- Current-Mode Control
- High Efficiency
- Up to 1MHz Internal Oscillator
- Internal Start-up Circuit

Applications

- DC/DC Converters
- Distributed Power Systems
- ISDN Equipment
- PBX Systems
- Modems

Absolute Maximum Ratings

$+V_{IN}$, Input Voltage	120V
V_{DS}	200V
V_{DD} , Logic Voltage	15.0V
Input Voltage Logic, Linear, FB and Sense	-0.3V to $V_{DD}+0.3V$
I_D (Peak)	2.5A
Storage Temperature	-65°C to 150°C
Power Dissipation, Plastic DIP	750mW
Power Dissipation, PLCC	1400mW

General Description

The Supertex HV9100 through HV9103 are a series of BiCMOS/DMOS single-output, pulse width modulator ICs intended for use in high-speed high-efficiency switchmode power supplies. They provide all the functions necessary to implement a single-switch current-mode PWM, in any topology, with a minimum of external parts.

Utilization of Supertex proprietary BiCMOS/DMOS technology results in a device with one tenth of the operating power of conventional bipolar PWM ICs, which can operate at more than twice their switching frequency. Dynamic range for regulation is also increased, to approximately 8 times that of similar bipolar parts. They start directly from any DC input voltage between 10 and 70VDC for the HV9100 or 10 to 120VDC for the HV9102 and HV9103, requiring no external power resistor. The output stage for the HV9100 is a 150V, 5.0 ohm MOSFET and for the HV9102 and HV9103 is a 200V, 7.0 ohm MOSFET. The clock frequency is set with a single external resistor.

Accessory functions are included to permit fast remote shutdown (latching or nonlatching), and undervoltage shutdown.

For detailed circuit and application information, please refer to application notes AN-H13 and AN-H21 to AN-H24.

Electrical Characteristics

($V_{DD} = 10V$, $+V_{IN} = 48V$, Discharge = $-V_{IN} = 0V$, $R_{BIAS} = 390K\Omega$, $R_{OSC} = 330K\Omega$, $T_A = 25^\circ C$, unless otherwise specified)

Symbol	Parameters	Min	Typ	Max	Unit	Conditions
--------	------------	-----	-----	-----	------	------------

Reference

V_{REF}	Output Voltage	HV9100/02/03	3.92	4.00	4.08	V	$R_L = 10M\Omega$
		HV9102/03	3.86	4.00	4.14	V	$I_N = V_{IN}$, $R_L = 10M\Omega$ $T_A = -55^\circ C$ to $125^\circ C$
Z_{OUT}	Output Impedance ¹	15	30	45	K Ω		
I_{SHORT}	Short Circuit Current		100	250	μA	$V_{REF} = -V_{IN}$	
ΔV_{REF}	Change in V_{REF} with Temperature		0.25		mV/ $^\circ C$		

Oscillator

f_{MAX}	Oscillator Frequency	1.0	3.0		MHz	$R_{OSC} = 0\Omega$
f_{OSC}	Initial Accuracy ²	80	100	120	KHz	$R_{OSC} = 330K\Omega$
		160	200	240		$R_{OSC} = 150K\Omega$
	Voltage Stability			15	%	$9.5V < V_{DD} < 13.5V$
	Temperature Coefficient		170		ppm/ $^\circ C$	

PWM

D_{MAX}	Maximum Duty Cycle	HV9100/02	49.0	49.4	49.6	%	
		HV9103	99.0	99.4	99.6		
	Deadtime	HV9103		100		nsec	
D_{MIN}	Minimum Duty Cycle				0	%	
				110	175	nsec	

Error Amplifier

V_{FB}	Feedback Voltage	HV9100/02/03	3.96	4.00	4.04	V	V_{FB} Shorted to Comp
I_{IN}	Input Bias Current			25	500	nA	$V_{FB} = 4.0V$
V_{OS}	Input Offset Voltage		nulled at trim			mV	Except 9101
A_{VOL}	Open Loop Voltage Gain ¹		60	80		dB	
gbw	Unity Gain Bandwidth ¹		1.0	1.3		MHz	
Z_{OUT}	Output Impedance ¹		See Fig. 2			Ω	
I_{SOURCE}	Output Source Current			-2.0	-1.4	mA	$V_{FB} = 3.4V$
I_{SINK}	Output Sink Current		0.12	0.15		mA	$V_{FB} = 4.5V$
PSRR	Power Supply Rejection		See Fig. 1				

Current Limit

V_{SOURCE}	Threshold Voltage		1.0	1.2	1.4	V	$V_{FB} = 0V$, $R_L = 100\Omega$
t_d	Delay to Output ¹				150	ns	$V_{SOURCE} = 1.5V$, $R_L = 100\Omega$

Notes:

1. Guaranteed by design. Not subject to production test.
2. Stray capacitance on OSC In pin $\leq 5pF$.

Electrical Characteristics (Continued)

($V_{DD} = 10V$, $+V_{IN} = 48V$, Discharge = $-V_{IN} = 0V$, $R_{BIAS} = 390K\Omega$, $R_{OSC} = 330K\Omega$, $T_A = 25^\circ C$, unless otherwise specified)

Symbol	Parameters	Min	Typ	Max	Unit	Conditions
--------	------------	-----	-----	-----	------	------------

Pre-Regulator/Startup

$+V_{IN}$	Allowable Input Voltage	HV9100		70	V	$I_{IN} = 10\mu A$
		HV9102/03		120		
	Input Leakage Current			10	μA	$V_{DD} > 9.4V$
V_{TH}	V_{DD} Pre-regulator Turn-off Threshold Voltage	7.8	8.6	9.4	V	$I_{PREREG} = 10\mu A$
V_{LOCK}	Undervoltage Lockout	7.0	8.1	8.9	V	$R_L = 100\Omega$ from Drain to V_{DD}

Supply

I_{DD}	Supply Current		0.60	1.0	mA	
			0.55		mA	Shutdown = $-V_{IN}$
I_{BIAS}	Bias Current		20		μA	
V_{DD}	Operating Range	9.0		13.5	V	

Logic

t_{SD}	Shutdown Delay Time ¹		50	100	ns	$V_{SOURCE} = -V_{IN}$
t_{SW}	Shutdown Pulse Width ¹	50			ns	
t_{RW}	RESET Pulse Width ¹	50			ns	
t_{LW}	Latching Pulse Width ¹	25			ns	
V_{IL}	Input Low Voltage			2.0	V	
V_{IH}	Input High Voltage	7.0			V	
I_{IH}	Input High Current		1.0	5.0	μA	$V_{IN} = 10V$
I_{IL}	Input Low Current		-25	-35	μA	$V_{IN} = 0V$

MOSFET Switch

BV_{DSS}	Breakdown Voltage	HV9100	150		V	$V_{SOURCE} = \overline{\text{Shutdown}} = 0V$, $I_D = 100\mu A$, $T_A = -55^\circ C$ to $125^\circ C$	
		HV9102/03	200				
$R_{DS(ON)}$	Drain-to-Source On-resistance	HV9100		3.5	5.0	Ω	$V_{SOURCE} = 0V$, $I_D = 100mA$
		HV9102/03			7.0	Ω	
I_{DSS}	OFF State Drain Leakage Current				10	μA	$V_{SOURCE} = \overline{\text{Shutdown}} = 0V$, $V_{DRAIN} = 100V$
C_{DS}	Drain Capacitance		35			pF	$V_{DS} = 25V$, $\overline{\text{Shutdown}} = 0V$

Note:

1. Guaranteed by design. Not subject to production test.

Truth Table

Shutdown	Reset	Output
H	H	Normal Operation
H	H → L	Normal Operation, No Change
L	H	Off, Not Latched
L	L	Off, Latched
L → H	L	Off, Latched, No Change

Switching Waveforms

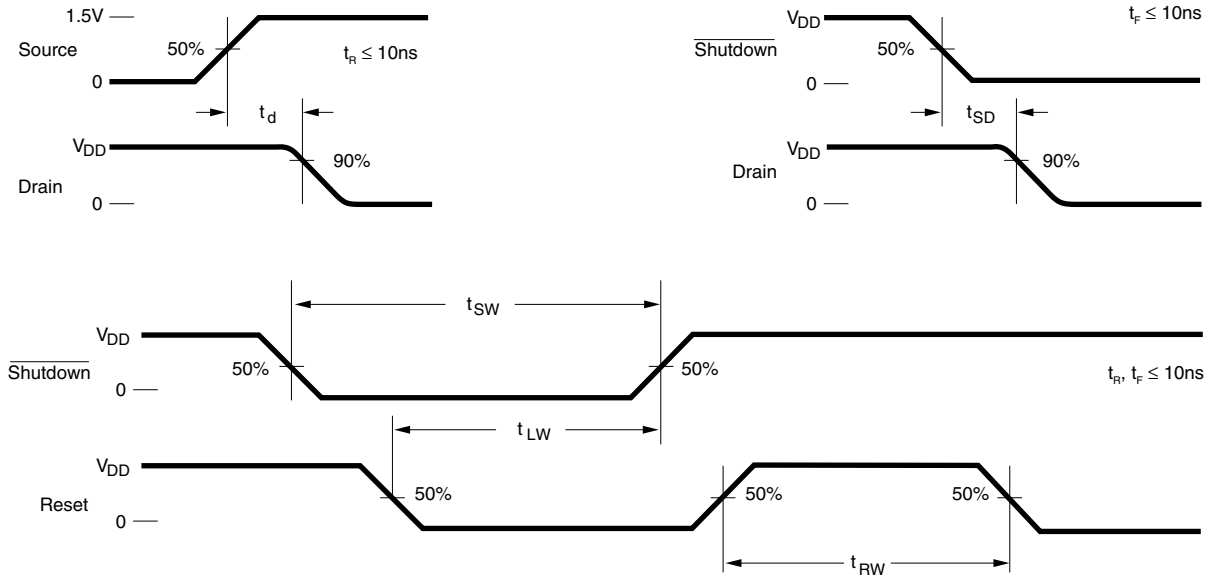

Functional Block Diagram

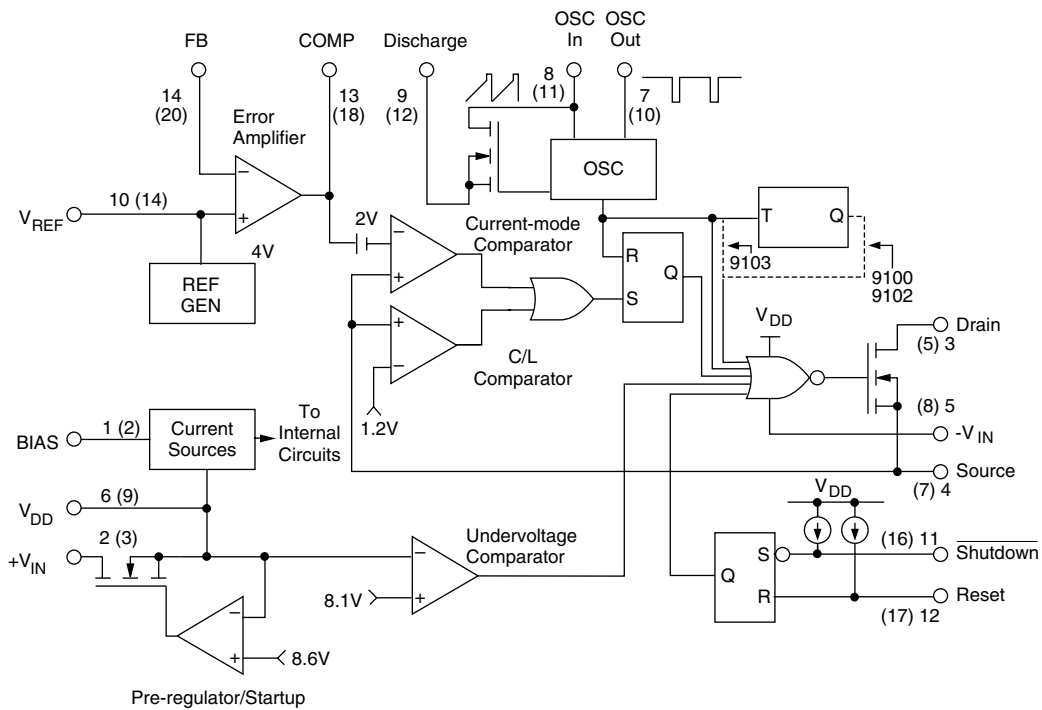

Pin numbers in parentheses are for PLCC package.

Typical Performance Curves

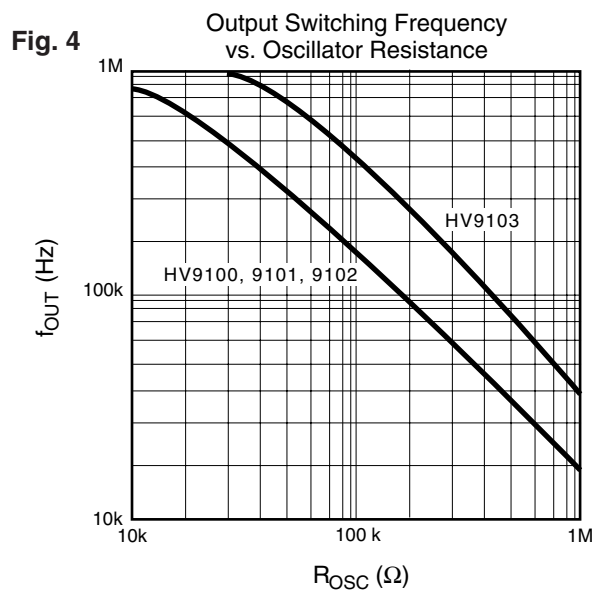
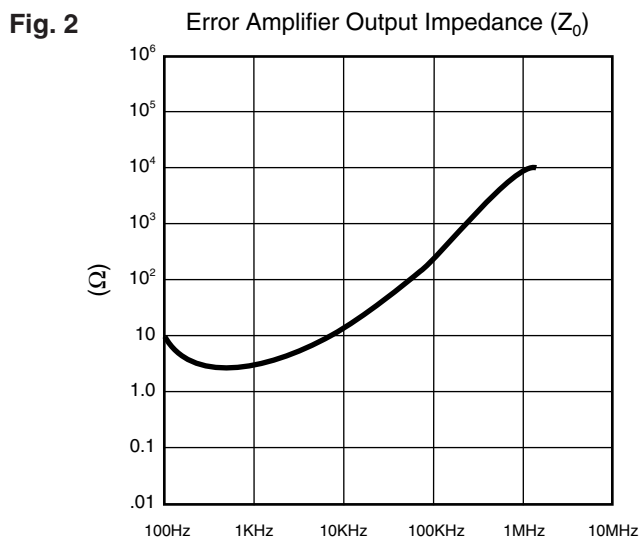
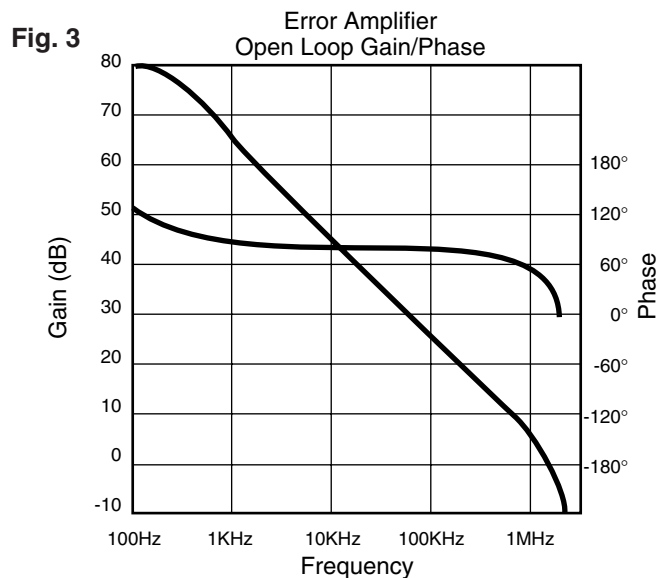
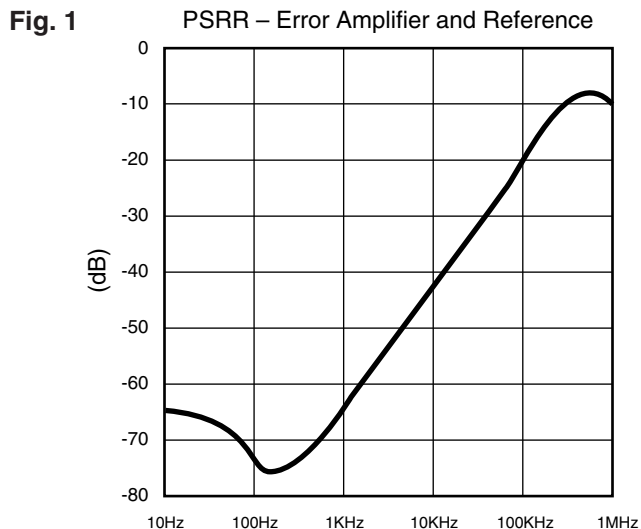

Test Circuits

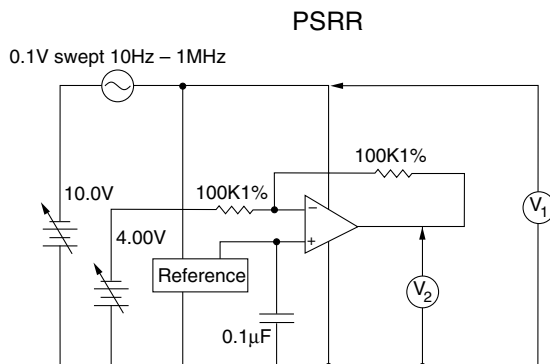
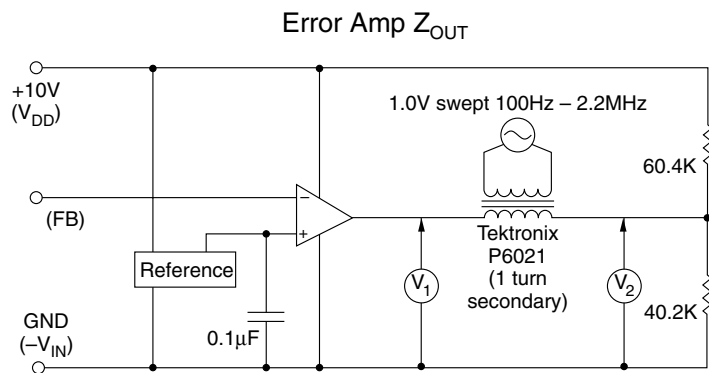

NOTE: Set Feedback Voltage so that $V_{COMP} = V_{DIVIDE} \pm 1mV$ before connecting transformer

Technical Description

Preregulator

The preregulator/startup circuit for the HV910x consists of a high-voltage N-channel depletion-mode DMOS transistor driven by an error amplifier to form a controlled current path between the V_{IN} terminal and the V_{DD} terminal. Maximum current (about 20 mA) occurs when $V_{DD} = 0$, with current reducing as V_{DD} rises. This path shuts off altogether when V_{DD} rises to somewhere between 7.8 and 9.4V, so that if V_{DD} is held at 10 or 12V by an external source (generally the supply the chip is controlling) no current other than leakage is drawn through the high voltage transistor. This minimizes dissipation.

An external capacitor between V_{DD} and V_{SS} is generally required to store energy used by the chip during the time between shutoff of the high voltage path and the V_{DD} supply's output rising enough to take over the powering of the chip. This capacitor generally also serves as the output filter capacitor for that output from the supply. 1 μ F is generally sufficient to assure against double-starting. Capacitors as small as 0.1 μ F can work when faster response from the V_{DD} line is required. Whatever capacitor is chosen should have very good high frequency characteristics. Stacked polyester or ceramic capacitors work well. Electrolytic capacitors are generally not suitable.

A common resistor divider string is used to monitor V_{DD} for both the undervoltage lockout circuit and the shutoff circuit of the high voltage FET. Setting the undervoltage sense point about 0.6V lower on the string than the FET shutoff point guarantees that the undervoltage lockout always releases before the FET shuts off.

Bias Circuit

An external bias resistor, connected between the bias pin and V_{SS} is required to set currents in a series of current mirrors used by the analog sections of the chip. Nominal external bias current requirement is 15 to 20 μ A, which can be set by a 390K Ω to 510K Ω resistor if a 10V V_{DD} is used, or a 510K Ω to 680K Ω resistor if a 12V V_{DD} is used. A precision resistor is NOT required; $\pm 5\%$ is fine.

For extremely low power operation, the value of bias current can be reduced to as low as 5 μ A by further increases in the value of the bias resistor. This will reduce quiescent current by about a third, reduce bandwidth of the error amp by about half, and slow the current sense comparator by about 30%.

Clock Oscillator

The clock oscillator of the HV910x consists of a ring of CMOS inverters, timing capacitors, a capacitor discharge FET, and, in the 50% maximum duty cycle versions, a frequency dividing flip-flop. A single external resistor between the OSC In and OSC Out pins is required to set oscillator frequency (see Fig. 4). For the 50% maximum duty cycle versions the 'Discharge' pin is internally connected to GND. For the 99% duty cycle version, 'Discharge' can either be connected to V_{SS} directly or connected to V_{SS} through a resistor used to set a deadtime.

One difference exists between the Supertex HV910x and competitive parts. The oscillator of the HV910x is shut off when a shutoff command is received. This saves about 150 μ A of quiescent current, which aids in situations where an absolute minimum of quiescent power dissipation is required.

Reference

The reference consists of a stable bandgap reference followed by a buffer amplifier which scales the voltage up to approximately 4.0V. The scaling resistors of the reference buffer amplifier are trimmed during manufacture so that the output of the error amplifier when connected in a gain of -1 configuration is as close to 4.000V as possible. This nulls out any input offset of the error amplifier. As a consequence, even though the observed reference voltage of a specific part may not be exactly 4V, the feedback voltage required for proper regulation will be 4V.

A resistor of approximately 50K Ω is placed internally between the output of the reference buffer amplifier and the circuitry it feeds (reference output pin and NON-INVERTING input to the error amplifier). This allows overriding the internal reference with a low-impedance voltage source $\leq 6V$. Using an external reference reinstates the input offset voltage of the error amplifier, and its effect of the exact value of feedback voltage required. In general, because the reference voltage of the Supertex HV910x is not noisy, as some previous devices have been, overriding the reference should seldom be necessary.

Because the reference is a high impedance node, and usually there will be significant electrical noise near it, a bypass capacitor between the reference pin and V_{SS} is strongly recommended. The reference buffer amplifier is intentionally compensated to be stable with a capacitive load of 0.01 to 0.1 μ F.

Error Amplifier

The error amplifier is a true low-power differential input operational amplifier intended for around-the-amplifier compensation. It is of mixed CMOS-bipolar construction: a PMOS input stage is used so the common-mode range includes ground and the input impedance is very high. This is followed by bipolar gain stages which provide high gain without the electrical noise of all-MOS amplifiers. The amplifier is unity-gain stable.

Current Sense Comparators

The HV910x uses a true dual comparator system with independent comparators for modulation and current limiting. This allows the designer greater latitude in compensation design, as there are no clamps (except ESD protection) on the compensation pin. Like the error amplifier, the comparators are of low-noise BiCMOS construction.

Remote Shutdown

The shutdown and reset pins can be used to perform either latching or non-latching shutdown of a converter as required. These pins have internal current source pull-ups so they can be driven from open-drain logic. When not used, they should be left open, or connected to V_{DD} .

Main Switch

The main switch is a normal N-channel power MOSFET. Unlike the situation with competitive devices, the body diode can be used if desired without destroying the chip.



LittleDiode supplies new, hard to find or obsolete electronic components and semiconductors all over the world.

With over two million different components listed you are sure to find the part you need.

Feel free to visit us today at our online store:

LittleDiode.com

Looking forward to providing you with the best possible service.