

3213 AND 3214

MICROPOWER, ULTRA-SENSITIVE HALL-EFFECT SWITCHES

Package Designator 'LH' Pinning (SOT23W)

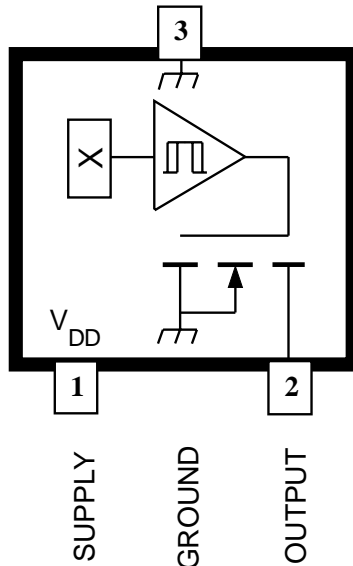

Dwg. PH-016-1

Pinning is shown viewed from branded side.

ABSOLUTE MAXIMUM RATINGS at $T_A = +25^\circ\text{C}$

Supply Voltage, V_{DD}	6 V
Magnetic Flux Density, B	Unlimited
Output Off Voltage, V_{OUT}	6 V
Output Current, I_{OUT}	1 mA
Junction Temperature, T_J	+170°C
Operating Temperature Range, T_A	
Suffix 'Ex'	-40°C to +85°C
Suffix 'Lx'	-40°C to +150°C
Storage Temperature Range,	
T_S	-65°C to +170°C

Caution: These CMOS devices have input static protection (Class 3) but are still susceptible to damage if exposed to extremely high static electrical charges.

The A3213xx and A3214xx integrated circuits are ultra-sensitive, pole independent Hall-effect switches with a latched digital output. They are especially suited for operation in battery-operated, hand-held equipment such as cellular and cordless telephones, pagers, and palmtop computers. A 2.4 volt to 5.5 volt operation and a unique clocking scheme reduce the average operating power requirements – the A3213xx to 825 μW , the A3214xx to 14 μW (typical at 2.75 V)! Except for operating duty cycle and average operating current, the A3213xx and A3214xx are identical.

Unlike other Hall-effect switches, either a north or south pole of sufficient strength will turn the output on; in the absence of a magnetic field, the output is off. The polarity independence and minimal power requirement allows these devices to easily replace reed switches for superior reliability and ease of manufacturing, while eliminating the requirement for signal conditioning.

Improved stability is made possible through chopper stabilization (dynamic offset cancellation), which reduces the residual offset voltage normally caused by device overmolding, temperature dependencies, and thermal stress.

These devices include on a single silicon chip a Hall-voltage generator, small-signal amplifier, chopper stabilization, a latch, and a MOSFET output. Advanced BiCMOS processing is used to take advantage of low-voltage and low-power requirements, component matching, very low input-offset errors, and small component geometries.

Suffix 'Ex' devices are rated for operation over a temperature range of -40°C to +85°C; suffix 'Lx' devices are rated for operation over a temperature range of -40°C to +150°C. Two package styles provide a magnetically optimized package for most applications. Package designator 'LH' is a miniature low-profile surface-mount package while designator 'UA' is a three-lead SIP for through-hole mounting.

FEATURES

- Micropower Operation
- Operate With North or South Pole
- 2.4 V to 5.5 V Battery Operation
- Chopper Stabilized
 - Superior Temperature Stability
 - Extremely Low Switch-Point Drift
 - Insensitive to Physical Stress
- ESD Protected to 5 kV
- Solid-State Reliability
- Small Size
- Easily Manufacturable With Magnet Pole Independence

Always order by complete part number: the prefix 'A' + the basic four-digit part number + a suffix letter to indicate operating temperature range + a two-letter suffix to indicate package style, e.g., **A3214ELH** .

3213 AND 3214 MICROPOWER, ULTRA-SENSITIVE HALL-EFFECT SWITCHES

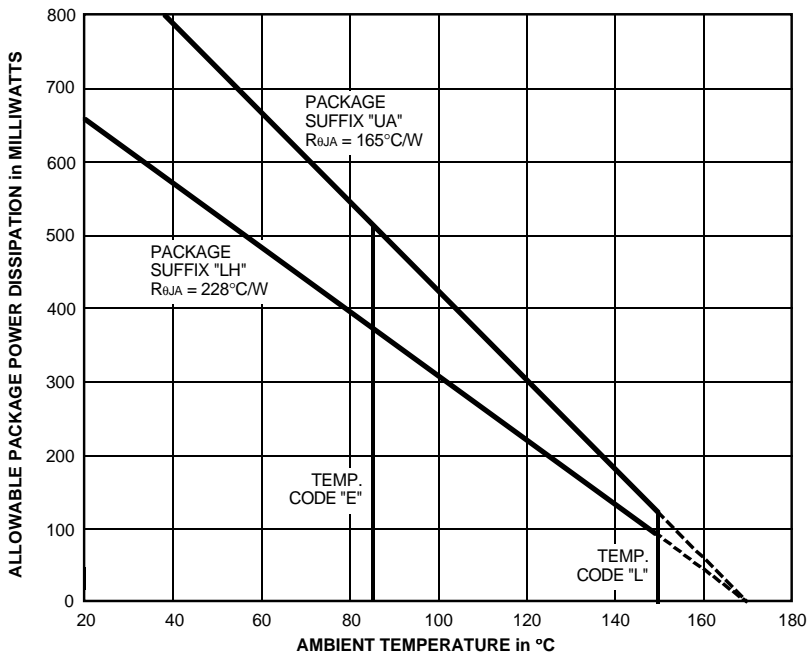
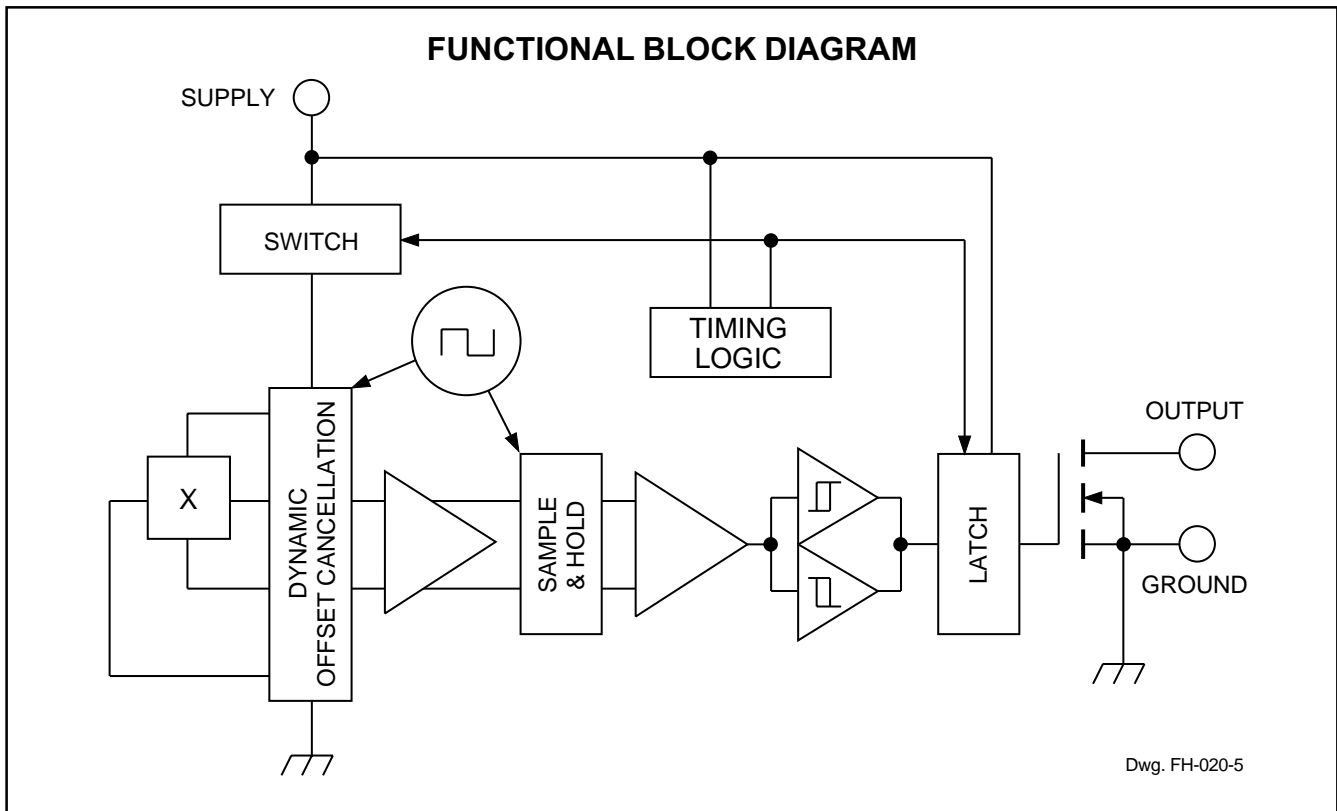

NOTE – Allowable package power dissipation will not be exceeded unless Absolute Maximum Ratings (page 1) are exceeded.

Package Designator 'UA' Pinning (SIP)

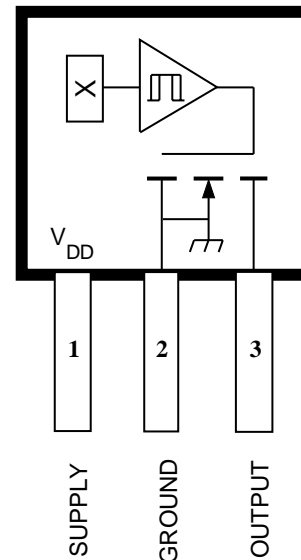

Pinning is shown viewed from branded side.

3213 AND 3214 MICROPOWER, ULTRA-SENSITIVE HALL-EFFECT SWITCHES

ELECTRICAL CHARACTERISTICS: unless otherwise noted over operating voltage and temperature range.

Characteristic	Symbol	Test Conditions	Limits			
			Min.	Typ.	Max.	Units
Supply Voltage Range	V_{DD}	Operating ¹⁾	2.4	3.0	5.5	V
Output Leakage Current	I_{OFF}	$V_{OUT} = 5.5\text{ V}$, $B_{RPN} < B < B_{RPS}$	–	<1.0	1.0	μA
Output On Voltage	V_{OUT}	$I_{OUT} = 1\text{ mA}$, $V_{DD} = 3.0\text{ V}$	–	100	300	mV
Awake Time	t_{awake}		–	60	90	μs
Period	t_{period}	A3213xx	–	240	360	μs
		A3214xx	–	60	90	ms
Duty Cycle	d.c.	A3213xx	–	25	–	%
		A3214xx	–	0.10	–	%
Chopping Frequency	f_C		–	340	–	kHz
Supply Current	$I_{DD(EN)}$	Chip awake (enabled)	–	–	2.0	mA
	$I_{DD(DIS)}$	Chip asleep (disabled)	–	–	8.0	μA
	$I_{DD(AVG)}$	A3213xx, $V_{DD} = 3.0\text{ V}$	–	295	500	μA
		A3213xx, $V_{DD} = 5.5\text{ V}$	–	460	700	μA
		A3214xx, $V_{DD} = 3.0\text{ V}$	–	5.0	10	μA
		A3214xx, $V_{DD} = 5.5\text{ V}$	–	11	15	μA
ESD, Human Body Model	–	Per CDF-AEC-Q100-002	5.0	–	–	kV
ESD, Machine Model	–	Per JESD22-A115	350	–	–	V

- NOTES: 1. Operate and release points will vary with supply voltage.
 2. B_{OPx} = operate point (output turns ON); B_{RPx} = release point (output turns OFF).
 3. Typical Data is at $T_A = +25^\circ\text{C}$ and $V_{DD} = 3.0\text{ V}$ and is for design information only.

MAGNETIC CHARACTERISTICS: over operating voltage and temperature range.

Characteristic	Symbol	Test Conditions	Limits			
			Min.	Typ.	Max.	Units
Operate Points	B_{OPS}	South pole to branded side	–	42	70	G
	B_{OPN}	North pole to branded side	-70	-48	–	G
Release Points	B_{RPS}	South pole to branded side	10	32	–	G
	B_{RPN}	North pole to branded side	–	-38	-10	G
Hysteresis	B_{hys}	$ B_{OPx} - B_{RPx} $	–	10	–	G

- NOTES: 1. As used here, negative flux densities are defined as less than zero (algebraic convention) and -50 G is less than +10 G.
 2. B_{OPx} = operate point (output turns ON); B_{RPx} = release point (output turns OFF).
 3. Typical Data is at $T_A = +25^\circ\text{C}$ and $V_{DD} = 3.0\text{ V}$ and is for design information only.
 4. 1 gauss (G) is exactly equal to 0.1 millitesla (mT).

**3213 AND 3214
MICROPOWER,
ULTRA-SENSITIVE
HALL-EFFECT SWITCHES**

**TYPICAL OPERATING CHARACTERISTICS
as a function of temperature ($V_{DD} = 3\text{ V}$)**

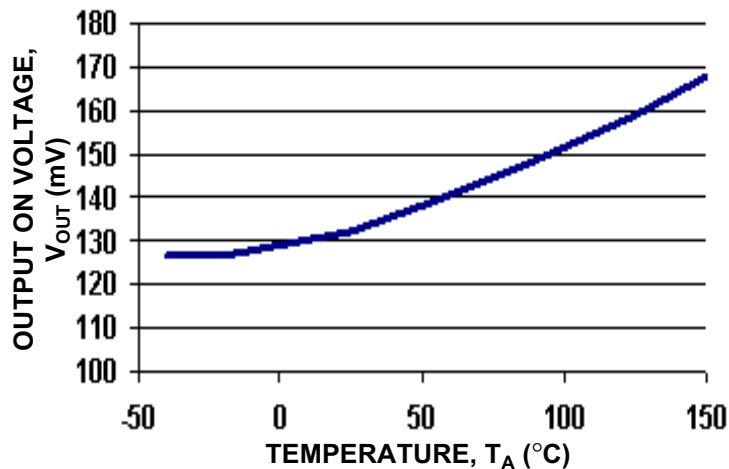
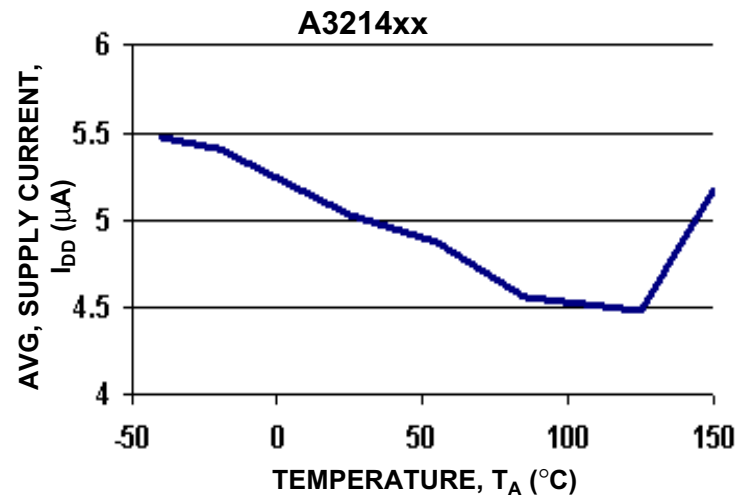
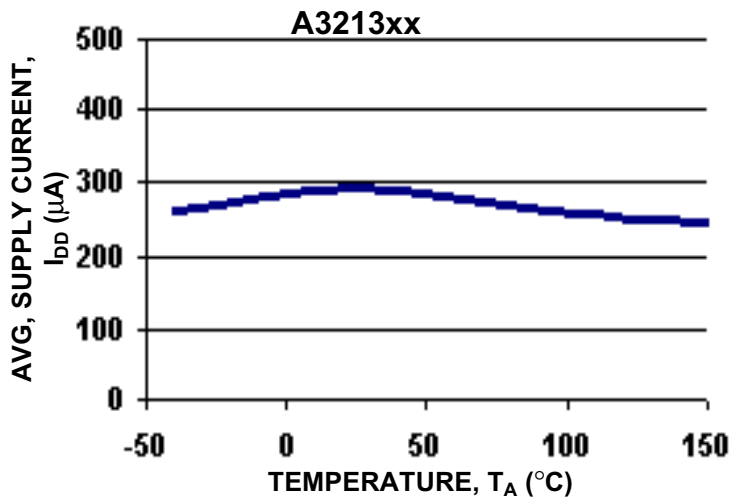
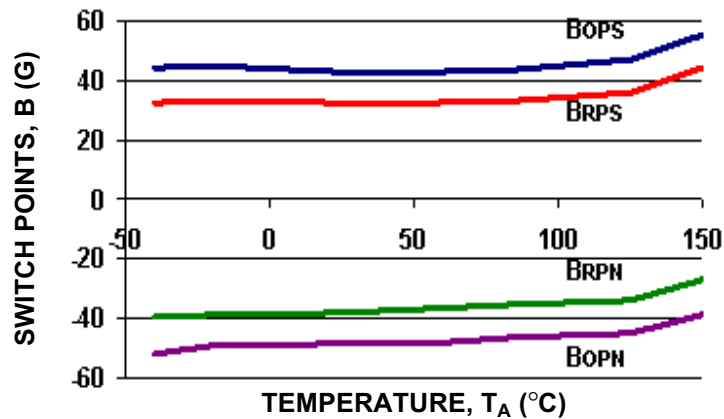

**3213 AND 3214
MICROPOWER,
ULTRA-SENSITIVE
HALL-EFFECT SWITCHES**

**TYPICAL OPERATING CHARACTERISTICS
as a function of supply voltage ($T_A = 25^\circ\text{C}$)**

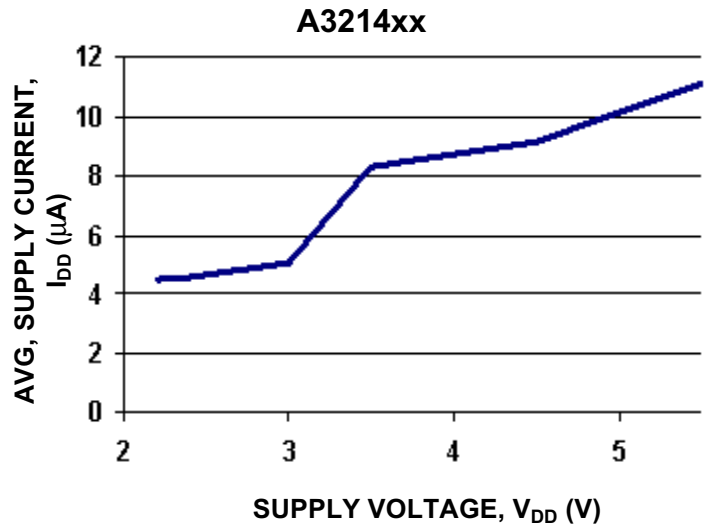
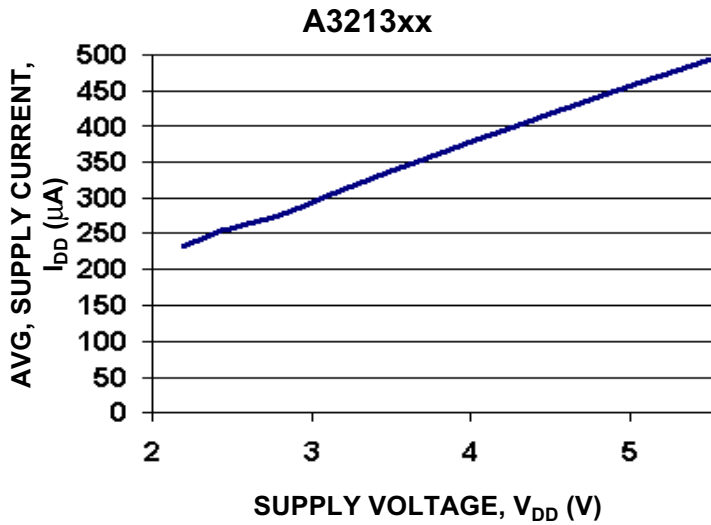
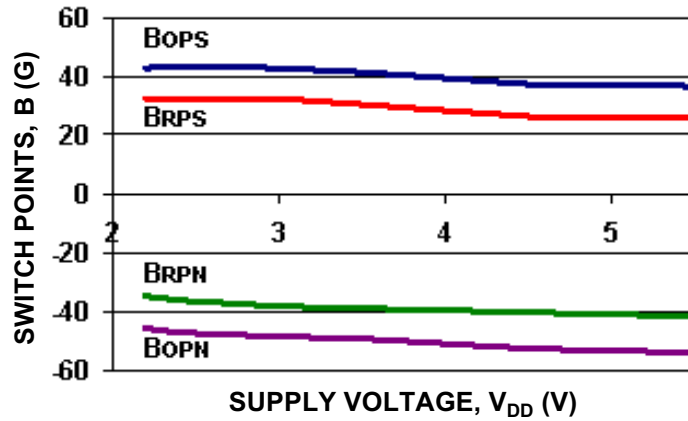

3213 AND 3214 MICROPOWER, ULTRA-SENSITIVE HALL-EFFECT SWITCHES

FUNCTIONAL DESCRIPTION

Low Average Power. Internal timing circuitry activates the sensor for 60 μs and deactivates it for the remainder of the period (240 μs for the A3213xx and 60 ms for the A3214xx). A short "awake" time allows for stabilization prior to the sensor sampling and data latching on the falling edge of the timing pulse. The output during the "sleep" time is latched in the last sampled state. The supply current is not affected by the output state.

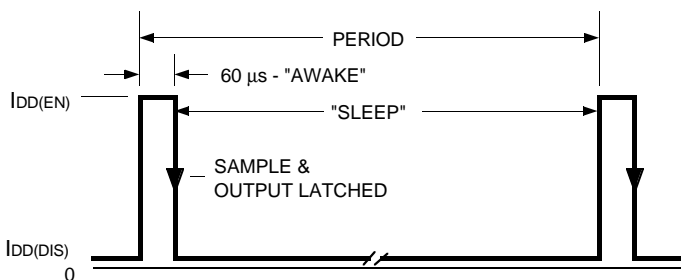

Dwg. WH-017-1

Chopper-Stabilized Technique. The Hall element can be considered as a resistor array similar to a Wheatstone bridge. A large portion of the offset is a result of the mismatching of these resistors. These devices use a proprietary dynamic offset cancellation technique, with an internal high-frequency clock to reduce the residual offset voltage of the Hall element that is normally caused by device overmolding, temperature dependencies, and thermal stress. The chopper-stabilizing technique cancels the mismatching of the resistor circuit by changing the direction of the current flowing through the Hall plate using CMOS switches and Hall voltage measurement taps, while maintaining the Hall-voltage signal that is induced by the external magnetic flux. The signal is then captured by a sample-and-hold circuit and further processed using low-offset bipolar circuitry. This technique produces devices that have an extremely stable quiescent Hall output voltage, are immune to thermal stress, and have precise recoverability after temperature cycling. This technique will also slightly degrade the device output repeatability. A relatively high sampling frequency is used in order that faster signals can be processed.

More detailed descriptions of the circuit operation can be found in Technical Paper STP 97-10, *Monolithic Magnetic Hall Sensor Using Dynamic Quadrature Offset Cancellation* and Technical Paper STP 99-1, *Chopper-Stabilized Amplifiers With A Track-and-Hold Signal Demodulator*.

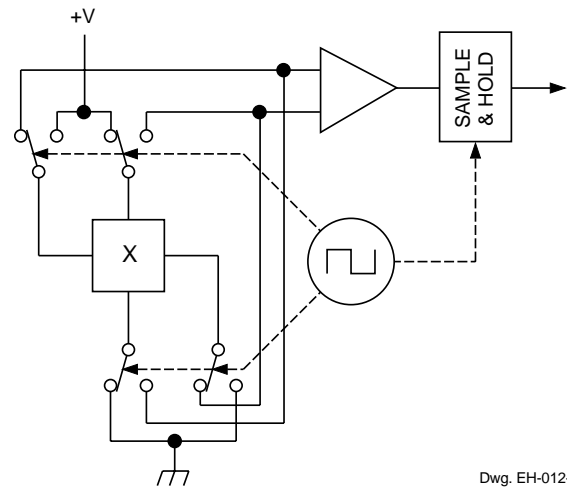

Dwg. EH-012-1

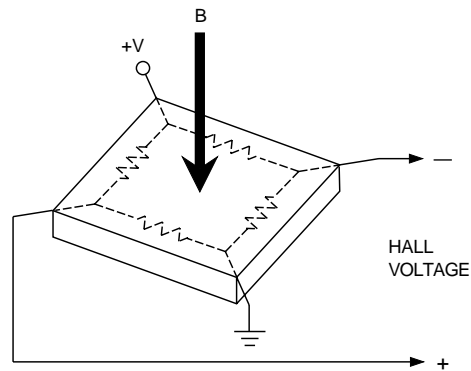

Dwg. AH-011-2

Operation. The output of this device switches low (turns on) when a magnetic field perpendicular to the Hall sensor exceeds the operate point B_{OPS} (or is less than B_{OPN}). After turn-on, the output is capable of sinking up to 1 mA and the output voltage is $V_{OUT(ON)}$. When the magnetic field is reduced below the release point B_{RPS} (or increased above B_{RPN}), the device output switches high (turns off). The difference in the magnetic operate and release points is the hysteresis (B_{HYS}) of the device. This built-in hysteresis allows clean switching of the output even in the presence of external mechanical vibration and electrical noise.

As used here, negative flux densities are defined as less than zero (algebraic convention) and -50 G is less than +10 G.

3213 AND 3214 MICROPOWER, ULTRA-SENSITIVE HALL-EFFECT SWITCHES

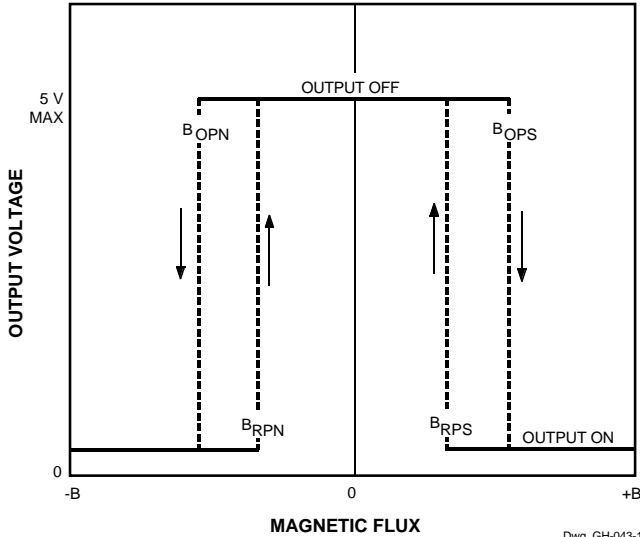

Applications. Allegro's pole-independent sensing technique allows for operation with either a north pole or south pole magnet orientation, enhancing the manufacturability of the device. The state-of-the-art technology provides the same output polarity for either pole face.

It is strongly recommended that an external bypass capacitor be connected (in close proximity to the Hall sensor) between the supply and ground of the device to reduce both external noise and noise generated by the chopper-stabilization technique. This is especially true due to the relatively high impedance of battery supplies.

The simplest form of magnet that will operate these devices is a bar magnet with either pole near the branded surface of the device. Many other methods of operation are possible. Extensive applications information on magnets and Hall-effect sensors is also available in the *Allegro Electronic Data Book AMS-702* or *Application Note 27701*, or at

www.allegromicro.com

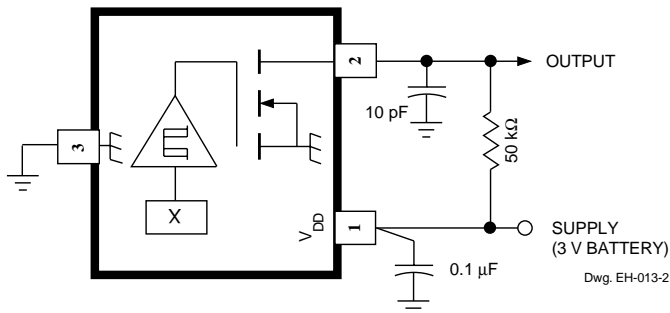

SENSOR LOCATIONS

Package Designator 'LH'

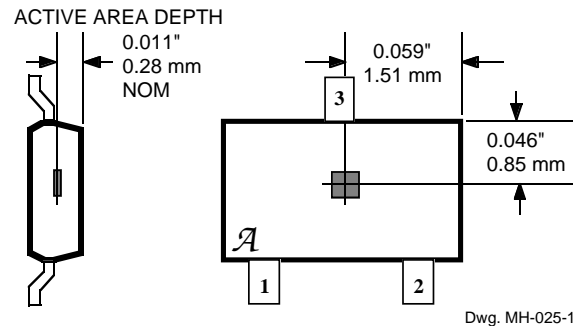

Package Designator 'UA'

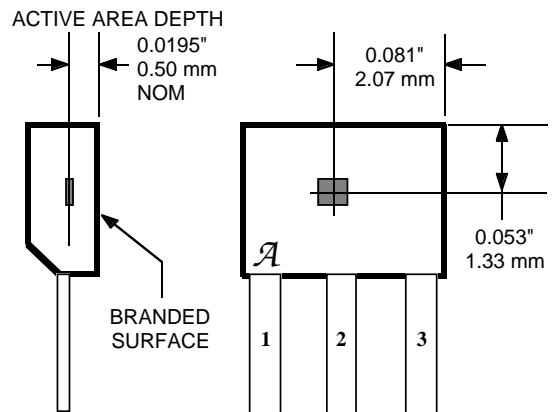

3213 AND 3214 MICROPOWER, ULTRA-SENSITIVE HALL-EFFECT SWITCHES

PACKAGE DESIGNATOR 'LH' (SOT23W, fits SC-59A solder-pad layout)

Dimensions in Inches
(for reference only)

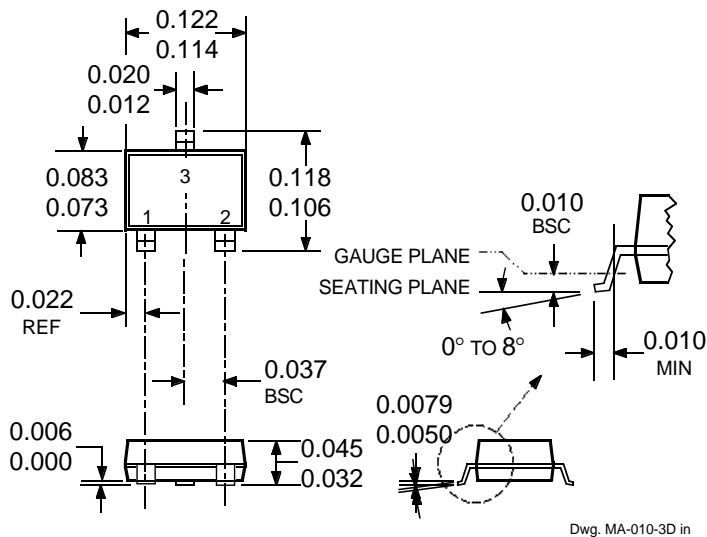

Dimensions in Millimeters
(controlling dimensions)

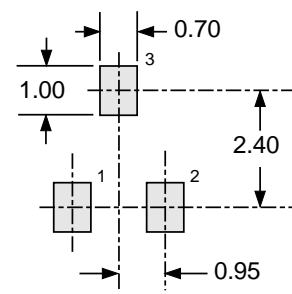
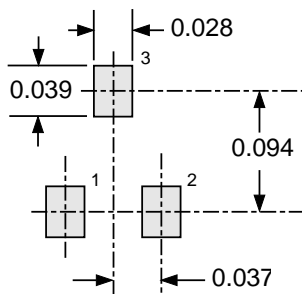
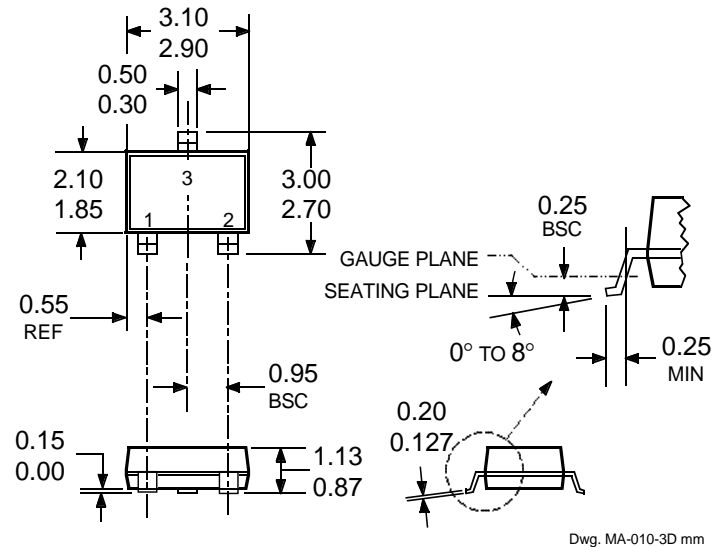

- NOTES: 1. Tolerances on package height and width represent allowable mold offsets. Dimensions given are measured at the widest point (parting line).
2. Exact body and lead configuration at vendor's option within limits shown.
3. Height does not include mold gate flash.
4. Where no tolerance is specified, dimension is nominal.
5. Add "LT" to part number for tape and reel.

3213 AND 3214 MICROPOWER, ULTRA-SENSITIVE HALL-EFFECT SWITCHES

PACKAGE DESIGNATOR 'UA'

Dimensions in Inches
(controlling dimensions)

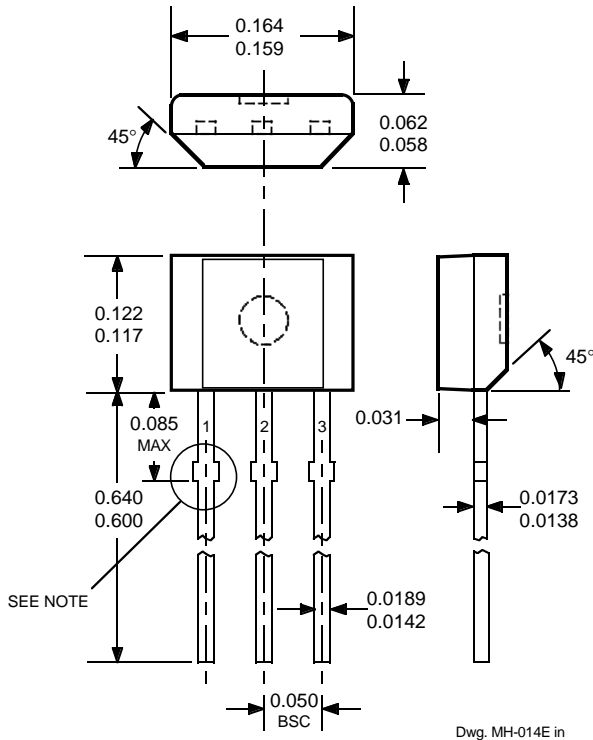

Dimensions in Millimeters
(for reference only)

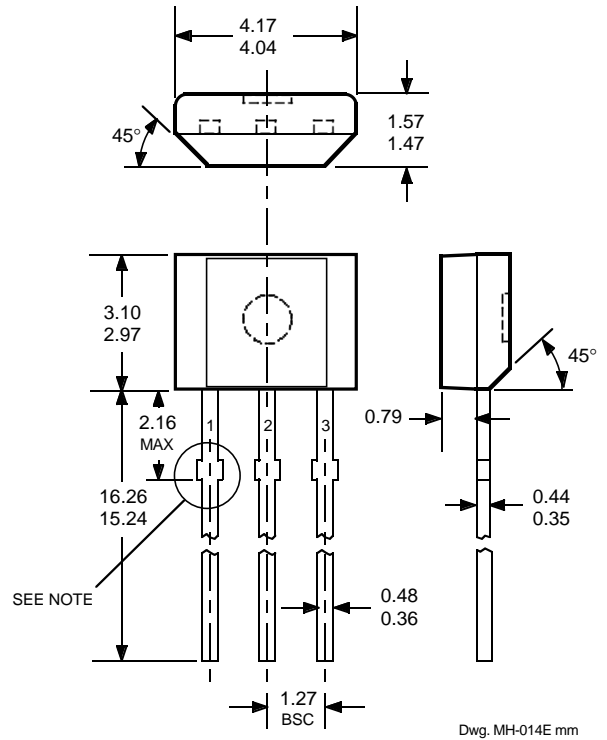

- NOTES: 1. Tolerances on package height and width represent allowable mold offsets. Dimensions given are measured at the widest point (parting line).
2. Exact body and lead configuration at vendor's option within limits shown.
3. Height does not include mold gate flash.
4. Recommended minimum PWB hole diameter to clear transition area is 0.035" (0.89 mm).
5. Where no tolerance is specified, dimension is nominal.
6. Supplied in bulk pack (500 pieces per bag).

Radial Lead Form (order A321xxUA-LC)

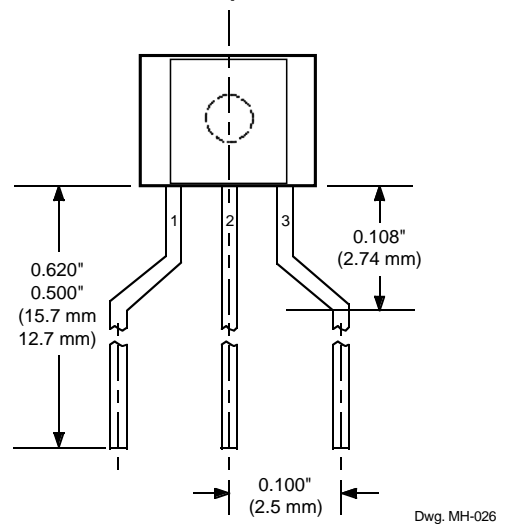

NOTE: Lead-form dimensions are the nominals produced on the forming equipment. No dimensional tolerance is implied or guaranteed for bulk packaging (500 pieces per bag).

**3213 AND 3214
MICROPOWER,
ULTRA-SENSITIVE
HALL-EFFECT SWITCHES**

The products described herein are manufactured under one or more of the following U.S. patents: 4,761,569; 5,619,137; 5,621,319. In addition, a patent is pending for Allegro's magnetic pole-independent feature. Allegro has several foreign counterpart patents as well. Allegro has not licensed any of these patents to any third party.

Allegro MicroSystems, Inc. reserves the right to make, from time to time, such departures from the detail specifications as may be required to permit improvements in the performance, reliability, or manufacturability of its products. Before placing an order, the user is cautioned to verify that the information being relied upon is current.

Allegro products are not authorized for use as critical components in life-support appliances, devices, or systems without express written approval.

The information included herein is believed to be accurate and reliable. However, Allegro MicroSystems, Inc. assumes no responsibility for its use; nor for any infringements of patents or other rights of third parties that may result from its use.



LittleDiode supplies new, hard to find or obsolete electronic components and semiconductors all over the world.

With over two million different components listed you are sure to find the part you need.

Feel free to visit us today at our online store:

LittleDiode.com

Looking forward to providing you with the best possible service.