

**Dual, 4.5MHz, BiMOS Operational Amplifier with MOSFET Input/Bipolar Output**

The CA3240A and CA3240 are dual versions of the popular CA3140 series integrated circuit operational amplifiers. They combine the advantages of MOS and bipolar transistors on the same monolithic chip. The gate-protected MOSFET (PMOS) input transistors provide high input impedance and a wide common-mode input voltage range (typically to 0.5V below the negative supply rail). The bipolar output transistors allow a wide output voltage swing and provide a high output current capability.

The CA3240A and CA3240 are compatible with the industry standard 1458 operational amplifiers in similar packages. The offset null feature is available only when these types are supplied in the 14 lead PDIP package (E1 suffix).

**Ordering Information**

PART NUMBER	TEMP. RANGE (°C)	PACKAGE	PKG. NO.
CA3240AE	-40 to 85	8 Ld PDIP	E8.3
CA3240AE1	-40 to 85	14 Ld PDIP	E14.3
CA3240E	-40 to 85	8 Ld PDIP	E8.3

**Functional Diagram**

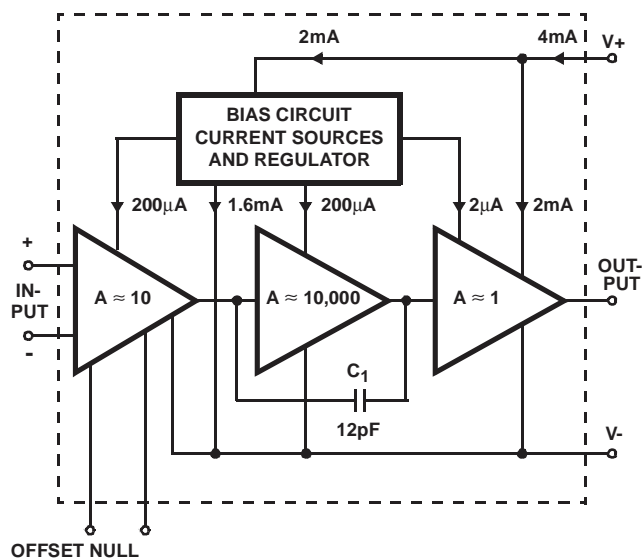

NOTE: Only available with 14 lead DIP (E1 Suffix).

**Features**

- Dual Version of CA3140
- Internally Compensated
- MOSFET Input Stage
  - Very High Input Impedance ( $Z_{IN}$ ) 1.5TΩ (Typ)
  - Very Low Input Current ( $I_I$ ) 10pA (Typ) at ±15V
  - Wide Common-Mode Input Voltage Range ( $V_{ICR}$ ): Can Be Swung 0.5V Below Negative Supply Voltage Rail
- Directly Replaces Industry Type 741 in Most Applications

**Applications**

- Ground Referenced Single Amplifiers in Automobile and Portable Instrumentation
- Sample and Hold Amplifiers
- Long Duration Timers/Multivibrators (Microseconds-Minutes-Hours)
- Photocurrent Instrumentation
- Intrusion Alarm System
- Comparators
- Instrumentation Amplifiers
- Active Filters
- Function Generators
- Power Supplies

**Pinouts**

**CA3240, CA3240A (PDIP) TOP VIEW**

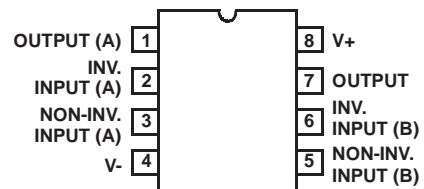

**CA3240A (PDIP) TOP VIEW**

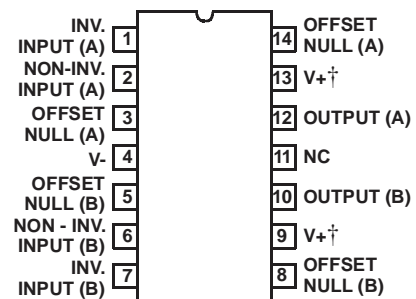

† Pins 9 and 13 internally connected through approximately 3Ω.

# CA3240, CA3240A

## Absolute Maximum Ratings

Supply Voltage (Between V+ and V-)	36V
Differential Input Voltage	8V
Input Voltage	(V+ +8V) to (V- -0.5V)
Input Current	1mA
Output Short Circuit Duration (Note 1)	Indefinite

## Thermal Information

Thermal Resistance (Typical, Note 2)	$\theta_{JA}$ (°C/W)
8 Lead PDIP Package	100
14 Lead PDIP Package	100
Maximum Junction Temperature (Plastic Package)	150°C
Maximum Storage Temperature Range	-65°C to 150°C
Maximum Lead Temperature (Soldering 10s)	300°C

## Operating Conditions

Temperature Range	-40°C to 85°C
Voltage Range	4V to 36V or ±2V to ±18V

CAUTION: Stresses above those listed in "Absolute Maximum Ratings" may cause permanent damage to the device. This is a stress only rating and operation of the device at these or any other conditions above those indicated in the operational sections of this specification is not implied.

### NOTES:

- Short circuit may be applied to ground or to either supply. Temperatures and/or supply voltages must be limited to keep dissipation within maximum rating.
- $\theta_{JA}$  is measured with the component mounted on an evaluation PC board in free air.

## Electrical Specifications For Equipment Design, $V_{SUPPLY} = \pm 15V$ , $T_A = 25^\circ C$ , Unless Otherwise Specified

PARAMETER	SYMBOL	CA3240			CA3240A			UNITS
		MIN	TYP	MAX	MIN	TYP	MAX	
Input Offset Voltage	$V_{IO}$	-	5	15	-	2	5	mV
Input Offset Current	$I_{IO}$	-	0.5	30	-	0.5	20	pA
Input Current	$I_I$	-	10	50	-	10	40	pA
Large-Signal Voltage Gain (See Figures 13, 28) (Note 3)	$A_{OL}$	20	100	-	20	100	-	kV/V
		86	100	-	86	100	-	dB
Common Mode Rejection Ratio (See Figure 18)	CMRR	-	32	320	-	32	320	$\mu V/V$
		70	90	-	70	90	-	dB
Common Mode Input Voltage Range (See Figure 25)	$V_{ICR}$	-15	-15.5 to +12.5	11	-15	-15.5 to +12.5	12	V
Power Supply Rejection Ratio (See Figure 20)	PSRR ( $\Delta V_{IO}/\Delta V_{\pm}$ )	-	100	150	-	100	150	$\mu V/V$
		76	80	-	76	80	-	dB
Maximum Output Voltage (Note 4) (See Figures 24, 25)	$V_{OM+}$	12	13	-	12	13	-	V
	$V_{OM-}$	-14	-14.4	-	-14	-14.4	-	V
Maximum Output Voltage (Note 5)	$V_{OM-}$	0.4	0.13	-	0.4	0.13	-	V
Total Supply Current (See Figure 16) For Both Amps	$I+$	-	8	12	-	8	12	mA
Total Device Dissipation	$P_D$	-	240	360	-	240	360	mW

### NOTES:

- At  $V_O = 26V_{P-P}$ , +12V, -14V and  $R_L = 2k\Omega$ .
- At  $R_L = 2k\Omega$ .
- At  $V+ = 5V$ ,  $V- = GND$ ,  $I_{SINK} = 200\mu A$ .

## Electrical Specifications For Equipment Design, $V_{SUPPLY} = \pm 15V$ , $T_A = 25^\circ C$ , Unless Otherwise Specified

PARAMETER	SYMBOL	TEST CONDITIONS	TYPICAL VALUES		UNITS
			CA3240A	CA3240	
Input Offset Voltage Adjustment Resistor (E1 Package Only)		Typical Value of Resistor Between Terminals 4 and 3(5) or Between 4 and 14(8) to Adjust Maximum $V_{IO}$	18	4.7	$k\Omega$
Input Resistance	$R_I$		1.5	1.5	$T\Omega$
Input Capacitance	$C_I$		4	4	pF
Output Resistance	$R_O$		60	60	$\Omega$
Equivalent Wideband Input Noise Voltage (See Figure 2)	$e_N$	BW = 140kHz, $R_S = 1M\Omega$	48	48	$\mu V$

## CA3240, CA3240A

### Electrical Specifications For Equipment Design, $V_{SUPPLY} = \pm 15V$ , $T_A = 25^\circ C$ , Unless Otherwise Specified (Continued)

PARAMETER	SYMBOL	TEST CONDITIONS	TYPICAL VALUES		UNITS	
			CA3240A	CA3240		
Equivalent Input Noise Voltage (See Figure 19)	$e_N$	$f = 1kHz, R_S = 100\Omega$	40	40	$nV/\sqrt{Hz}$	
		$f = 10kHz, R_S = 100\Omega$	12	12	$nV/\sqrt{Hz}$	
Short-Circuit Current to Opposite Supply	$I_{OM+}$	Source	40	40	mA	
	$I_{OM-}$	Sink	11	11	mA	
Gain Bandwidth Product (See Figures 14, 28)	$f_T$		4.5	4.5	MHz	
Slew Rate (See Figure 15)	SR		9	9	$V/\mu s$	
Transient Response (See Figure 1)	$t_r$	$R_L = 2k\Omega, C_L = 100pF$	Rise Time	0.08	0.08	$\mu s$
	OS	$R_L = 2k\Omega, C_L = 100pF$	Overshoot	10	10	%
Settling Time at $10V_{P-P}$ (See Figure 26)	$t_S$	$A_V = +1, R_L = 2k\Omega, C_L = 100pF,$ Voltage Follower	To 1mV	4.5	4.5	$\mu s$
			To 10mV	1.4	1.4	$\mu s$
Crosstalk (See Figure 23)		$f = 1kHz$		120	120	dB

### Electrical Specifications For Equipment Design, at $V_{SUPPLY} = \pm 15V$ , $T_A = -40$ to $85^\circ C$ , Unless Otherwise Specified

PARAMETER	SYMBOL	TYPICAL VALUES		UNITS
		CA3240A	CA3240	
Input Offset Voltage	$ V_{IO} $	3	10	mV
Input Offset Current (Note 8)	$ I_{IO} $	32	32	pA
Input Current (Note 8)	$I_I$	640	640	pA
Large Signal Voltage Gain (See Figures 13, 28), (Note 6)	$A_{OL}$	63	63	kV/V
		96	96	dB
Common Mode Rejection Ratio (See Figure 18)	CMRR	32	32	$\mu V/V$
		90	90	dB
Common Mode Input Voltage Range (See Figure 25)	$V_{ICR}$	-15 to +12.3	-15 to +12.3	V
Power Supply Rejection Ratio (See Figure 20)	PSRR ( $\Delta V_{IO}/\Delta V_{\pm}$ )	150	150	$\mu V/V$
		76	76	dB
Maximum Output Voltage (Note 7) (See Figures 24, 25)	$V_{OM+}$	12.4	12.4	V
	$V_{OM-}$	-14.2	-14.2	V
Supply Current (See Figure 16) Total For Both Amps	$I_+$	8.4	8.4	mA
Total Device Dissipation	$P_D$	252	252	mW
Temperature Coefficient of Input Offset Voltage	$\Delta V_{IO}/\Delta T$	15	15	$\mu V/^\circ C$

NOTES:

6. At  $V_O = 26V_{P-P}$ , +12V, -14V and  $R_L = 2k\Omega$ .
7. At  $R_L = 2k\Omega$ .
8. At  $T_A = 85^\circ C$ .

### Electrical Specifications For Equipment Design, at $V_+ = 5V$ , $V_- = 0V$ , $T_A = 25^\circ C$ , Unless Otherwise Specified

PARAMETER	SYMBOL	TYPICAL VALUES		UNITS
		CA3240A	CA3240	
Input Offset Voltage	$ V_{IO} $	2	5	mV
Input Offset Current	$ I_{IO} $	0.1	0.1	pA
Input Current	$I_I$	2	2	pA
Input Resistance	$R_{IN}$	1	1	$T\Omega$
Large Signal Voltage Gain (See Figures 13, 28)	$A_{OL}$	100	100	kV/V
		100	100	dB

# CA3240, CA3240A

**Electrical Specifications** For Equipment Design, at  $V_+ = 5V$ ,  $V_- = 0V$ ,  $T_A = 25^\circ C$ , Unless Otherwise Specified **(Continued)**

PARAMETER	SYMBOL	TYPICAL VALUES		UNITS	
		CA3240A	CA3240		
Common-Mode Rejection Ratio	CMRR	32	32	$\mu V/V$	
		90	90	dB	
Common-Mode Input Voltage Range (See Figure 25)	$V_{ICR}$	-0.5	-0.5	V	
		2.6	2.6	V	
Power Supply Rejection Ratio	PSRR	31.6	31.6	$\mu V/V$	
		90	90	dB	
Maximum Output Voltage (See Figures 24, 25)	$V_{OM+}$	3	3	V	
	$V_{OM-}$	0.3	0.3	V	
Maximum Output Current	Source	$I_{OM+}$	20	20	mA
	Sink	$I_{OM-}$	1	1	mA
Slew Rate (See Figure 15)	SR	7	7	$V/\mu s$	
Gain Bandwidth Product (See Figure 14)	$f_T$	4.5	4.5	MHz	
Supply Current (See Figure 16)	$I_+$	4	4	mA	
Device Dissipation	$P_D$	20	20	mW	

## Test Circuits and Waveforms

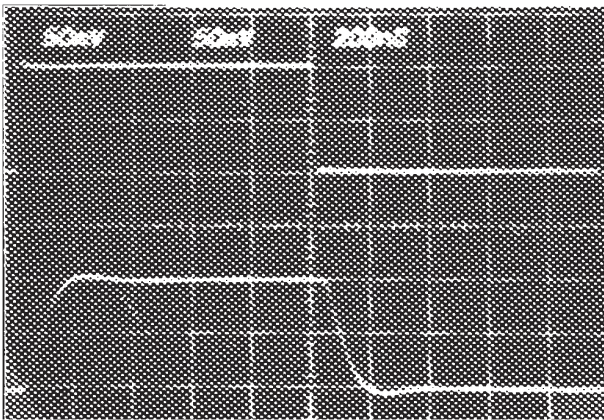

50mV/Div., 200ns/Div.  
Top Trace: Input, Bottom Trace: Output

**FIGURE 1A. SMALL SIGNAL RESPONSE**

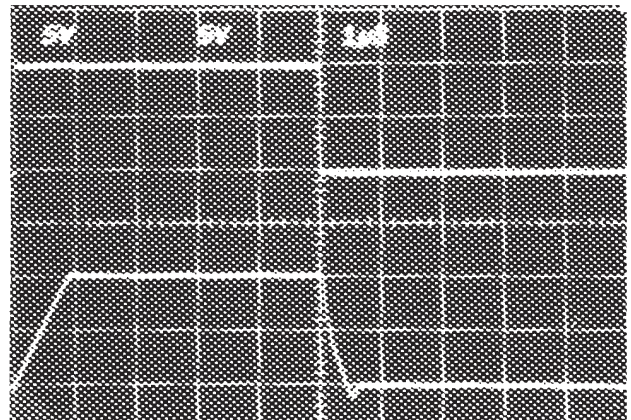

5V/Div., 1μs/Div.  
Top Trace: Input, Bottom Trace: Output

**FIGURE 1B. LARGE SIGNAL RESPONSE**

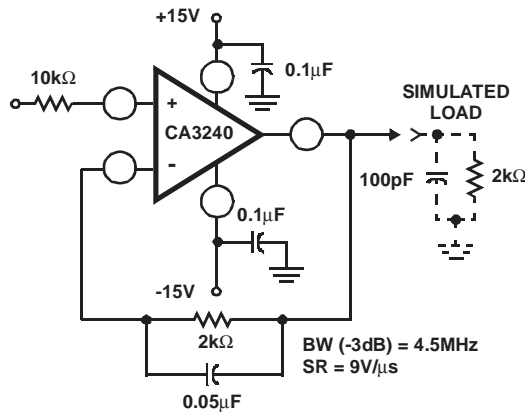

**FIGURE 1C. TEST CIRCUIT**

**FIGURE 1. SPLIT-SUPPLY VOLTAGE FOLLOWER TEST CIRCUIT AND ASSOCIATED WAVEFORMS**

Test Circuits and Waveforms (Continued)

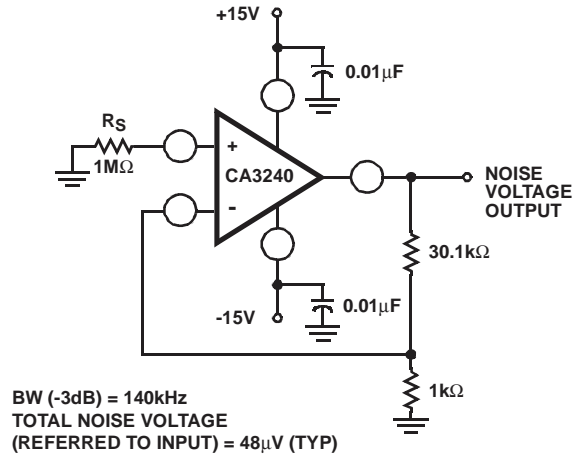
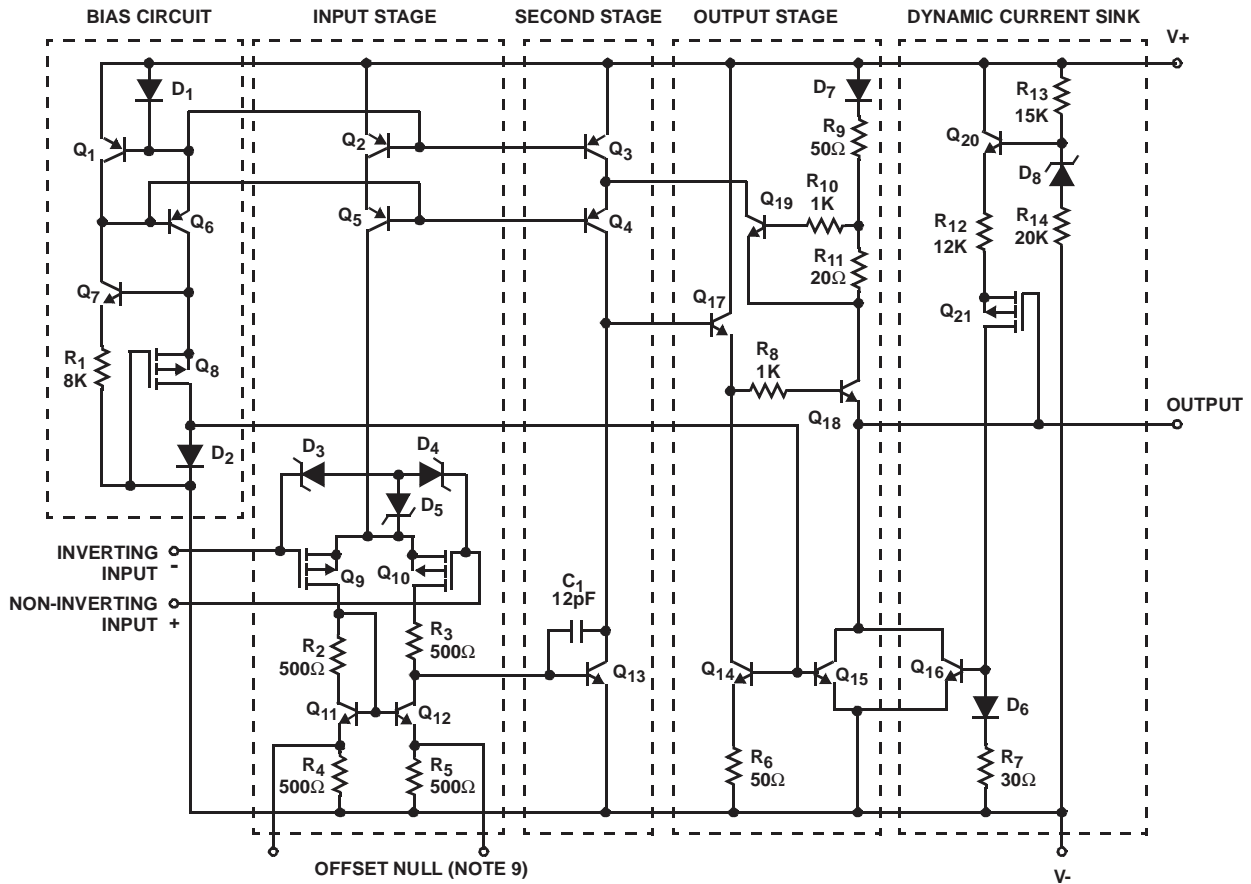

FIGURE 2. TEST CIRCUIT AMPLIFIER (30dB GAIN) USED FOR WIDEBAND NOISE MEASUREMENT

Schematic Diagram (One Amplifier of Two)



NOTES:

- 9. Only available with 14 Lead DIP (E1 Suffix).
- 10. All resistance values are in ohms.

## Application Information

### Circuit Description

The schematic diagram details one amplifier section of the CA3240. It consists of a differential amplifier stage using PMOS transistors ( $Q_9$  and  $Q_{10}$ ) with gate-to-source protection against static discharge damage provided by zener diodes  $D_3$ ,  $D_4$ , and  $D_5$ . Constant current bias is applied to the differential amplifier from transistors  $Q_2$  and  $Q_5$  connected as a constant current source. This assures a high common-mode rejection ratio. The output of the differential amplifier is coupled to the base of gain stage transistor  $Q_{13}$  by means of an NPN current mirror that supplies the required differential-to-single-ended conversion. Provision for offset null for types in the 14 lead plastic package (E1 suffix) is provided through the use of this current mirror.

The gain stage transistor  $Q_{13}$  has a high impedance active load ( $Q_3$  and  $Q_4$ ) to provide maximum open-loop gain. The collector of  $Q_{13}$  directly drives the base of the compound emitter-follower output stage. Pull-down for the output stage is provided by two independent circuits: (1) constant-current-connected transistors  $Q_{14}$  and  $Q_{15}$  and (2) dynamic current-sink transistor  $Q_{16}$  and its associated circuitry. *The level of pull-down current is constant at about 1mA for  $Q_{15}$  and varies from 0 to 18mA for  $Q_{16}$  depending on the magnitude of the voltage between the output terminal and  $V_+$ .* The dynamic current sink becomes active whenever the output terminal is more negative than  $V_+$  by about 15V. When this condition exists, transistors  $Q_{21}$  and  $Q_{16}$  are turned on causing  $Q_{16}$  to sink current from the output terminal to  $V_-$ . This current always flows when the output is in the linear region, either from the load resistor or from the emitter of  $Q_{18}$  if no load resistor is present. The purpose of this dynamic sink is to permit the output to go within 0.2V ( $V_{CE(sat)}$ ) of  $V_-$  with a 2k $\Omega$  load to ground. *When the load is returned to  $V_+$ , it may be necessary to supplement the 1mA of current from  $Q_{15}$  in order to turn on the dynamic current sink ( $Q_{16}$ ).* This may be accomplished by placing a resistor (Approx. 2k $\Omega$ ) between the output and  $V_-$ .

### Output Circuit Considerations

Figure 24 shows output current-sinking capabilities of the CA3240 at various supply voltages. Output voltage swing to the negative supply rail permits this device to operate both power transistors and thyristors directly without the need for level-shifting circuitry usually associated with the 741 series of operational amplifiers.

Figure 3 shows some typical configurations. Note that a series resistor,  $R_L$ , is used in both cases to limit the drive available to the driven device. Moreover, it is recommended that a series diode and shunt diode be used at the thyristor input to prevent large negative transient surges that can appear at the gate of thyristors, from damaging the integrated circuit.

### Input Circuit Considerations

As indicated by the typical VICR, this device will accept inputs as low as 0.5V below  $V_-$ . However, a series current-limiting resistor is recommended to limit the maximum input terminal current to less than 1mA to prevent damage to the input protection circuitry.

Moreover, some current-limiting resistance should be provided between the inverting input and the output when the CA3240 is used as a unity-gain voltage follower. This resistance prevents the possibility of extremely large input-signal transients from forcing a signal through the input-protection network and directly driving the internal constant-current source which could result in positive feedback via the output terminal. A 3.9k $\Omega$  resistor is sufficient.

The typical input current is on the order of 10pA when the inputs are centered at nominal device dissipation. As the output supplies load current, device dissipation will increase, raising the chip temperature and resulting in increased input current. Figure 4 shows typical input-terminal current versus ambient temperature for the CA3240.

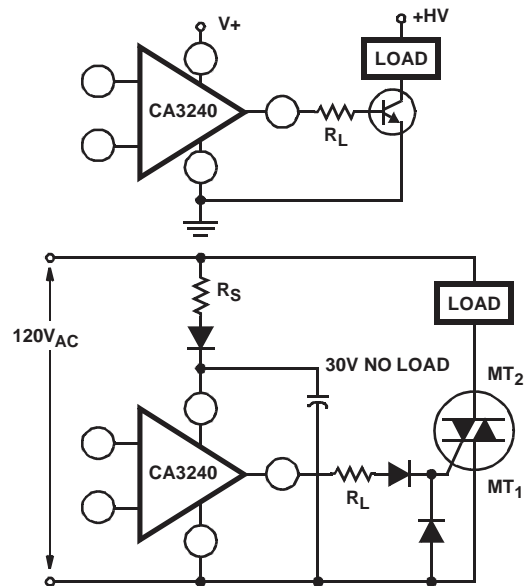

FIGURE 3. METHODS OF UTILIZING THE  $V_{CE(sat)}$  SINKING CURRENT CAPABILITY OF THE CA3240 SERIES

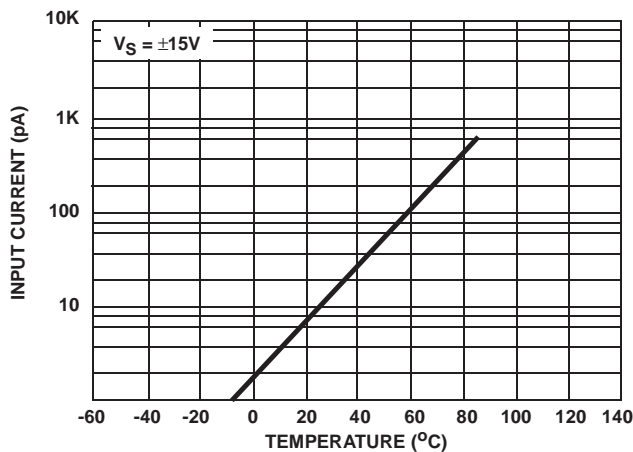

FIGURE 4. INPUT CURRENT vs TEMPERATURE

It is well known that MOSFET devices can exhibit slight changes in characteristics (for example, small changes in input offset voltage) due to the application of large differential input voltages that are sustained over long periods at elevated temperatures.

Both applied voltage and temperature accelerate these changes. The process is reversible and offset voltage shifts of the opposite polarity reverse the offset. In typical linear applications, where the differential voltage is small and symmetrical, these incremental changes are of about the same magnitude as those encountered in an operational amplifier employing a bipolar transistor input stage.

#### Offset-Voltage Nulling

The input offset voltage of the CA3240AE1 and CA3240E1 can be nulled by connecting a 10k $\Omega$  potentiometer between Terminals 3 and 14 or 5 and 8 and returning its wiper arm to Terminal 4, see Figure 5A. This technique, however, gives more adjustment range than required and therefore, a considerable portion of the potentiometer rotation is not fully utilized. Typical values of series resistors that may be placed at either end of the potentiometer, see Figure 5B, to optimize its utilization range are given in the table "Electrical Specifications for Equipment Design" shown on third page of this data sheet. An alternate system is shown in Figure 5C. This circuit uses only one additional resistor of approximately the value shown in the table. For potentiometers, in which the resistance does not drop to 0 $\Omega$  at either end of rotation, a value of resistance 10% lower than the values shown in the table should be used.

### Typical Applications

#### On/Off Touch Switch

The on/off touch switch shown in Figure 6 uses the CA3240E to sense small currents flowing between two contact points on a touch plate consisting of a PC board metallization "grid". When the "on" plate is touched, current flows between the two halves of the grid causing a positive

shift in the output voltage (Terminal 7) of the CA3240E. These positive transitions are fed into the CA3059, which is used as a latching circuit and zero-crossing TRIAC driver. When a positive pulse occurs at Terminal 7 of the CA3240E, the TRIAC is turned on and held on by the CA3059 and its associated positive feedback circuitry (51k $\Omega$  resistor and 36k $\Omega$ /42k $\Omega$  voltage divider). When the positive pulse occurs at Terminal 1 (CA3240E), the TRIAC is turned off and held off in a similar manner. Note that power for the CA3240E is supplied by the CA3059 internal power supply.

The advantage of using the CA3240E in this circuit is that it can sense the small currents associated with skin conduction while allowing sufficiently high circuit impedance to provide protection against electrical shock.

#### Dual Level Detector (Window Comparator)

Figure 7 illustrates a simple dual liquid level detector using the CA3240E as the sensing amplifier. This circuit operates on the principle that most liquids contain enough ions in solution to sustain a small amount of current flow between two electrodes submerged in the liquid. The current, induced by an 0.5V potential applied between two halves of a PC board grid, is converted to a voltage level by the CA3240E in a circuit similar to that of the on/off touch switch shown in Figure 6. The changes in voltage for both the upper and lower level sensors are processed by the CA3140 to activate an LED whenever the liquid level is above the upper sensor or below the lower sensor.

#### Constant-Voltage/Constant-Current Power Supply

The constant-voltage/constant-current power supply shown in Figure 8 uses the CA3240E1 as a voltage-error and current-sensing amplifier. The CA3240E1 is ideal for this application because its input common-mode voltage range includes ground, allowing the supply to adjust from 20mV to 25V without requiring a negative supply voltage. Also, the ground reference capability of the CA3240E1 allows it to sense the voltage across the 1 $\Omega$  current-sensing resistor in the negative output lead of the power supply. The CA3086 transistor array functions as a reference for both constant-voltage and constant-current limiting. The 2N6385 power Darlington is used as the pass element and may be required to dissipate as much as 40W. Figure 9 shows the transient response of the supply during a 100mA to 1A load transition.

#### Precision Differential Amplifier

Figure 10 shows the CA3240E in the classical precision differential amplifier circuit. The CA3240E is ideally suited for biomedical applications because of its extremely high input impedance. To insure patient safety, an extremely high electrode series resistance is required to limit any current that might result in patient discomfort in the event of a fault condition. In this case, 10M $\Omega$  resistors have been used to limit the current to less than 2 $\mu$ A without affecting the performance of the circuit. Figure 11 shows a typical electrocardiogram waveform obtained with this circuit.

# CA3240, CA3240A

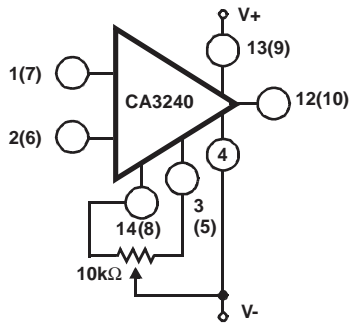

FIGURE 5A. BASIC

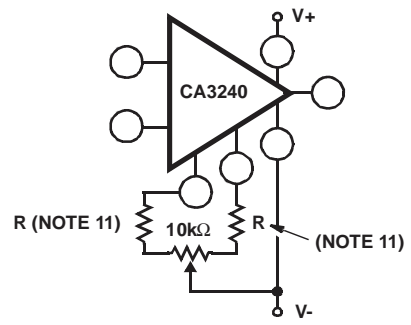

FIGURE 5B. IMPROVED RESOLUTION

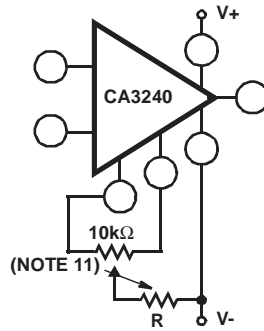
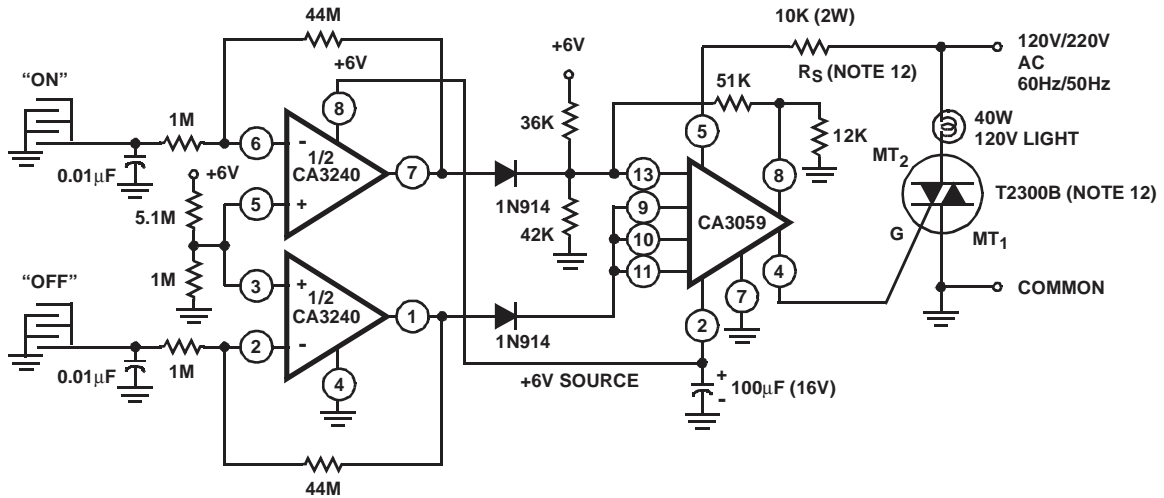

FIGURE 5C. SIMPLER IMPROVED RESOLUTION

NOTE:

11. See Electrical Specification Table for value of R.

FIGURE 5. THREE OFFSET-VOLTAGE NULLING METHODS, (CA3240AE1 ONLY)



NOTE:

12. At 220V operation, TRIAC should be T2300D,  $R_S = 18K$ , 5W.

FIGURE 6. ON/OFF TOUCH SWITCH

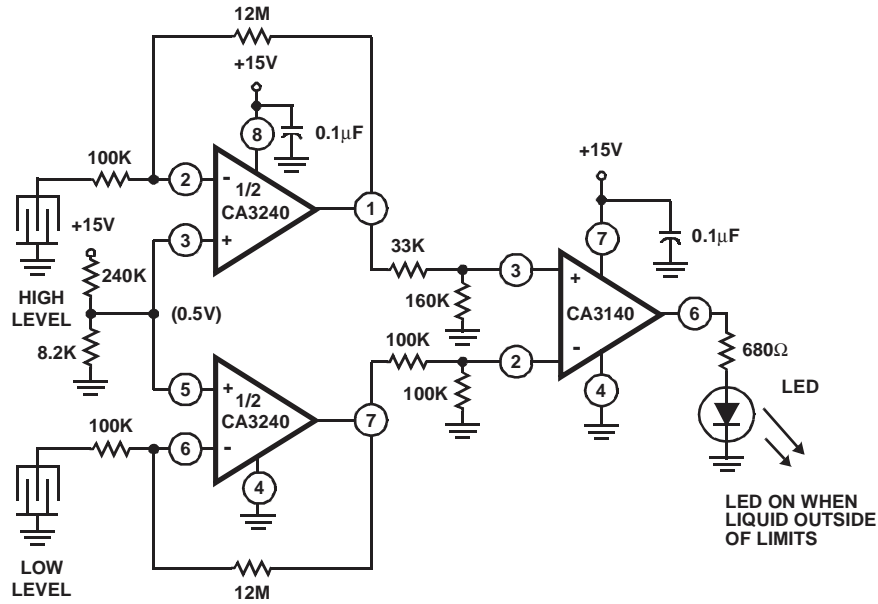

FIGURE 7. DUAL LEVEL DETECTOR

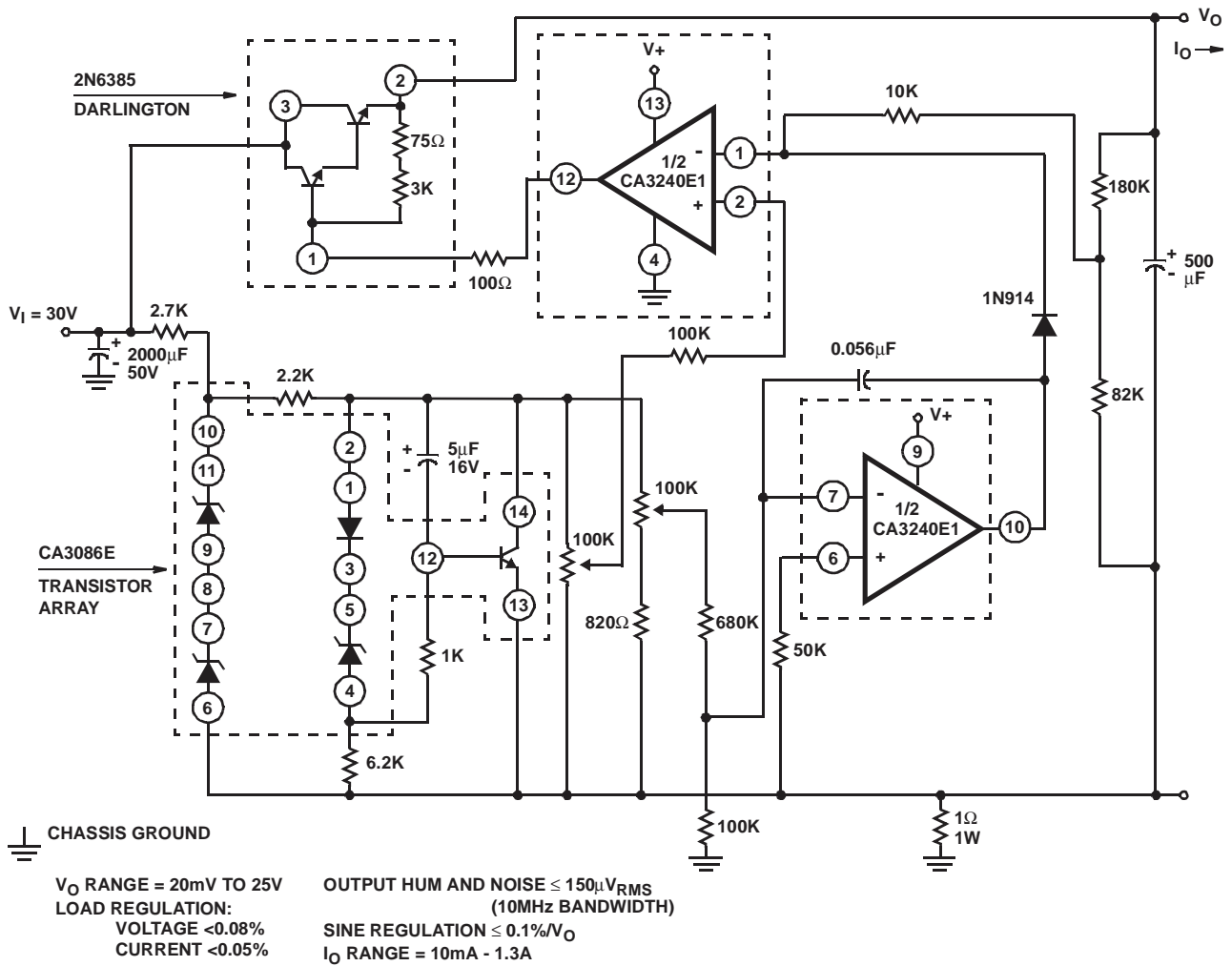
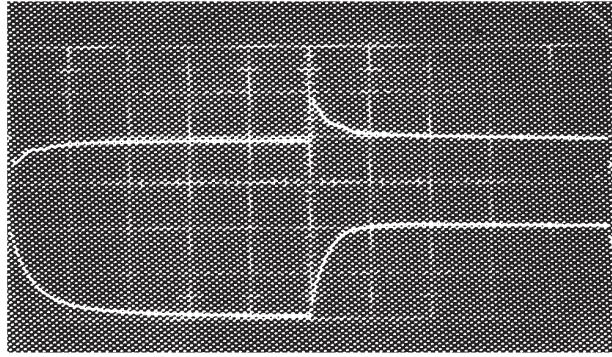

FIGURE 8. CONSTANT-VOLTAGE/CONSTANT-CURRENT POWER SUPPLY



Top Trace: Output Voltage;  
500mV/Div., 5 $\mu$ s/Div.

Bottom Trace: Collector Of Load Switching Transistor  
Load = 100mA to 1A; 5V/Div., 5 $\mu$ s/Div.

FIGURE 9. TRANSIENT RESPONSE

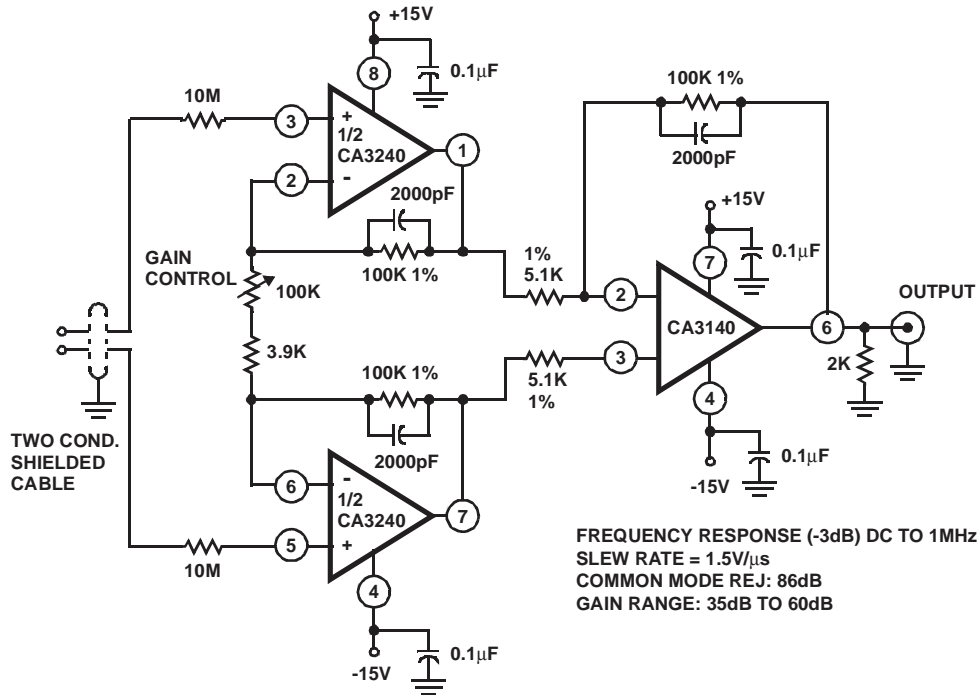
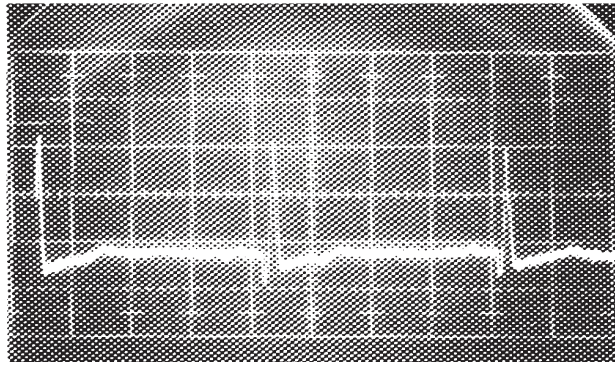

FIGURE 10. PRECISION DIFFERENTIAL AMPLIFIER



Vertical: 1.0mV/Div.  
 Amplifier Gain = 100X  
 Scope Sensitivity = 0.1V/Div.  
 Horizontal: >0.2s/Div. (Uncal)

FIGURE 11. TYPICAL ELECTROCARDIOGRAM WAVEFORM

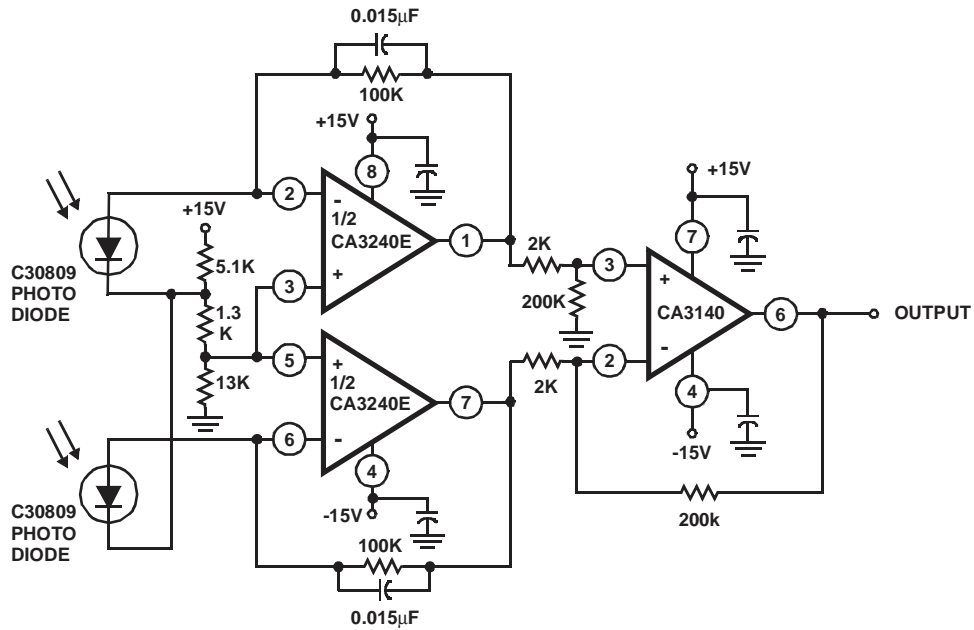

FIGURE 12. DIFFERENTIAL LIGHT DETECTOR

**Differential Light Detector**

In the circuit shown in Figure 12, the CA3240E converts the current from two photo diodes to voltage, and applies 1V of reverse bias to the diodes. The voltages from the CA3240E outputs are subtracted in the second stage (CA3140) so that

only the difference is amplified. In this manner, the circuit can be used over a wide range of ambient light conditions without circuit component adjustment. Also, when used with a light source, the circuit will not be sensitive to changes in light level as the source ages.

Typical Performance Curves

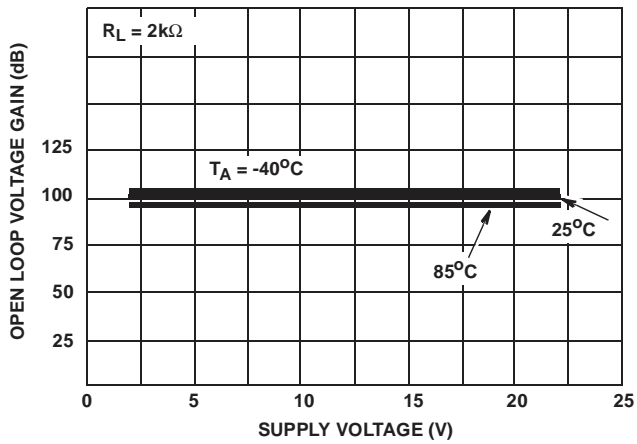

FIGURE 13. OPEN LOOP VOLTAGE GAIN vs SUPPLY VOLTAGE

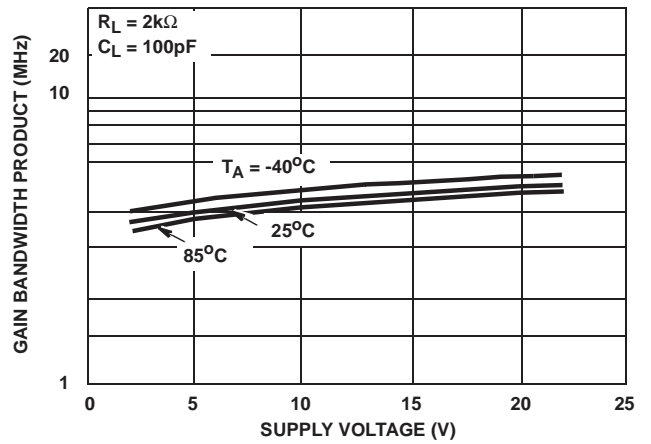

FIGURE 14. GAIN BANDWIDTH PRODUCT vs SUPPLY VOLTAGE

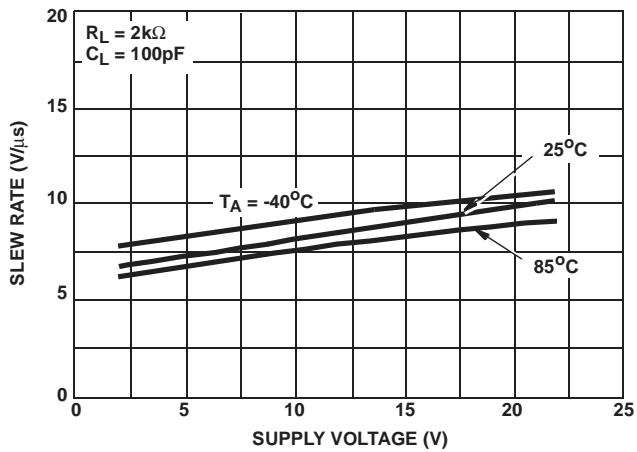

FIGURE 15. SLEW RATE vs SUPPLY VOLTAGE

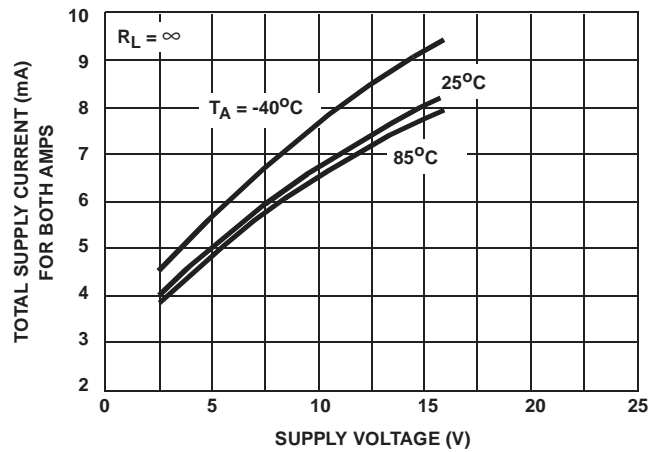

FIGURE 16. QUIESCENT SUPPLY CURRENT vs SUPPLY VOLTAGE

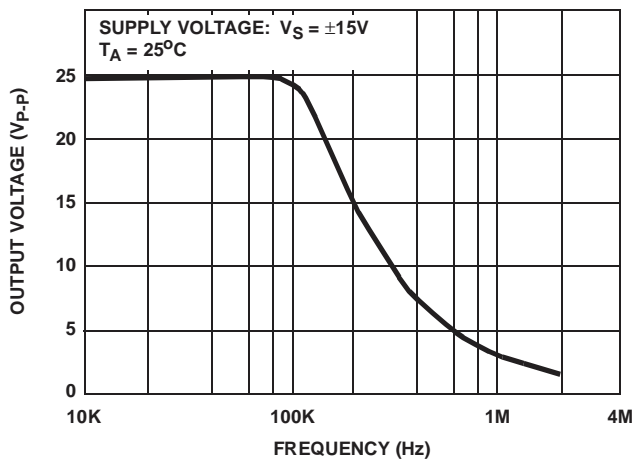

FIGURE 17. MAXIMUM OUTPUT VOLTAGE SWING vs FREQUENCY

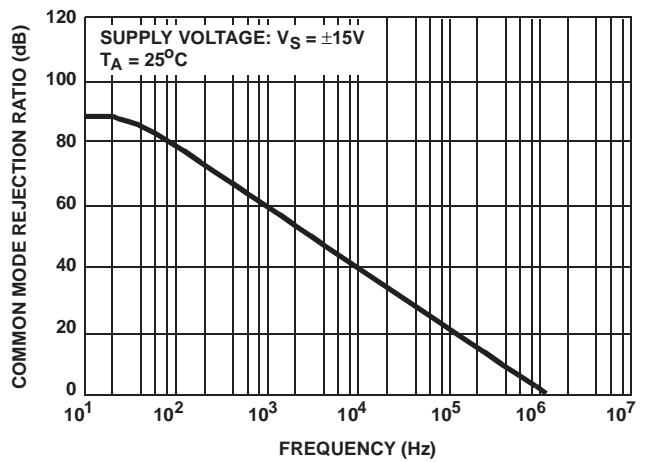

FIGURE 18. COMMON MODE REJECTION RATIO vs FREQUENCY

Typical Performance Curves (Continued)

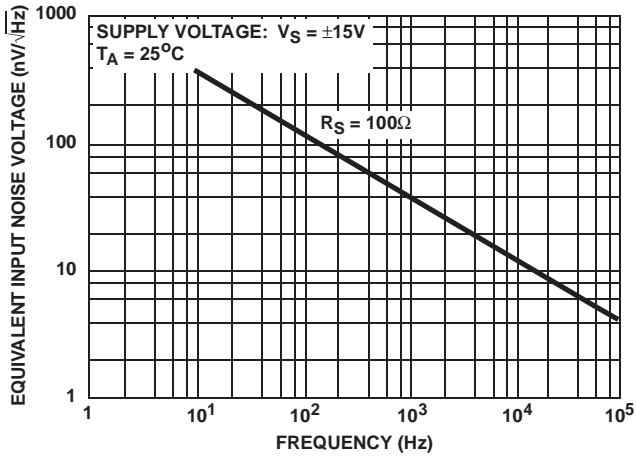

FIGURE 19. EQUIVALENT INPUT NOISE VOLTAGE vs FREQUENCY

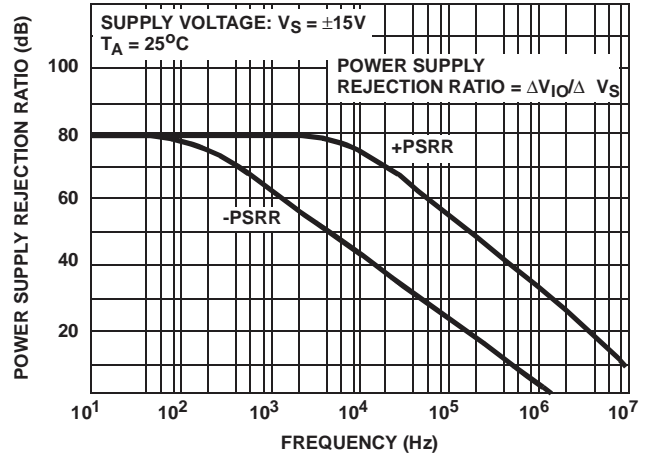

FIGURE 20. POWER SUPPLY REJECTION RATIO vs FREQUENCY

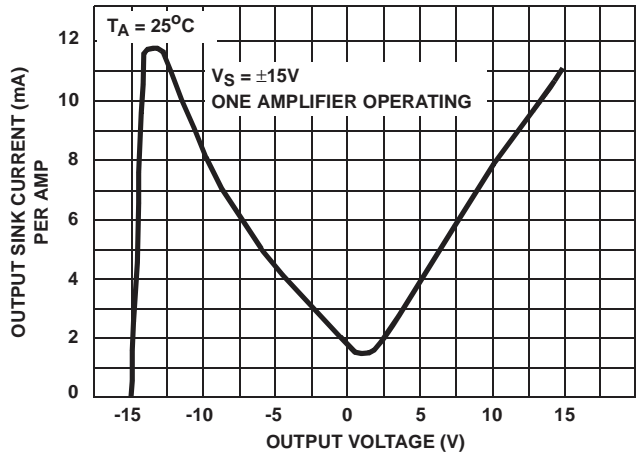

FIGURE 21. OUTPUT SINK CURRENT vs OUTPUT VOLTAGE

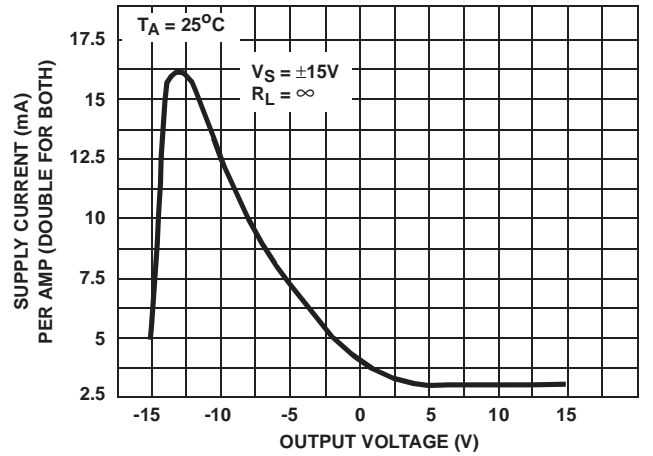

FIGURE 22. SUPPLY CURRENT vs OUTPUT VOLTAGE

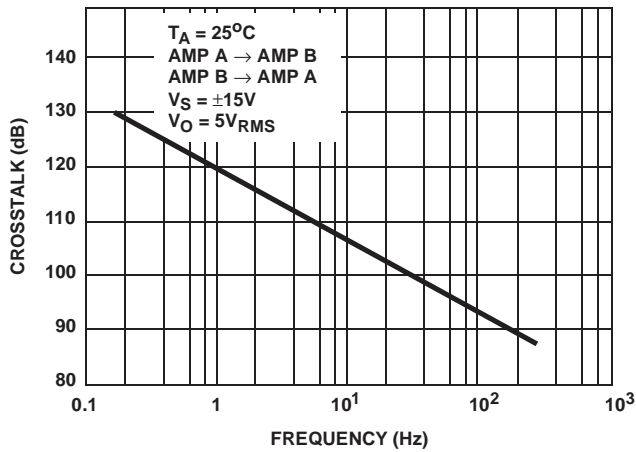

FIGURE 23. CROSSTALK vs FREQUENCY

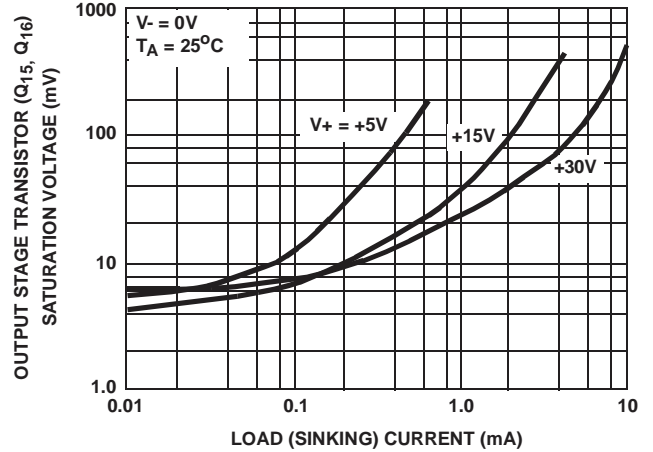

FIGURE 24. VOLTAGE ACROSS OUTPUT TRANSISTORS Q<sub>15</sub> AND Q<sub>16</sub> vs LOAD CURRENT

Typical Performance Curves (Continued)

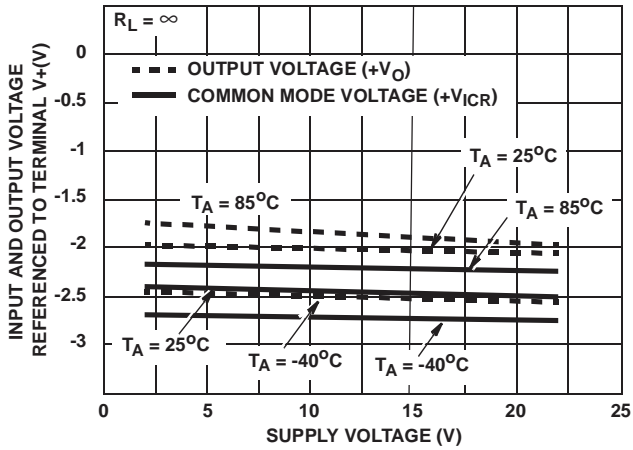

FIGURE 25A.

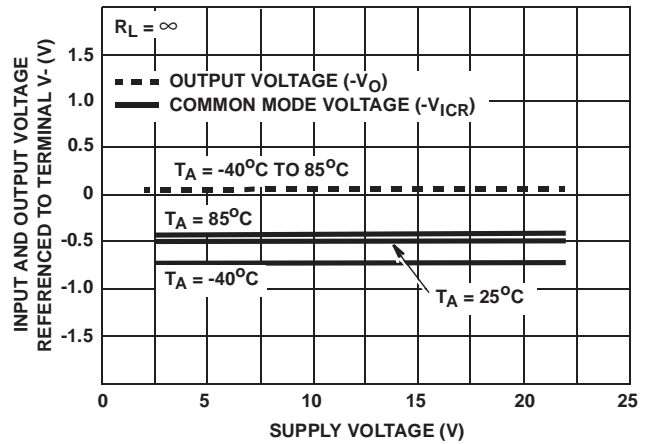

FIGURE 25B.

FIGURE 25. OUTPUT VOLTAGE SWING CAPABILITY AND COMMON MODE INPUT VOLTAGE RANGE vs SUPPLY VOLTAGE

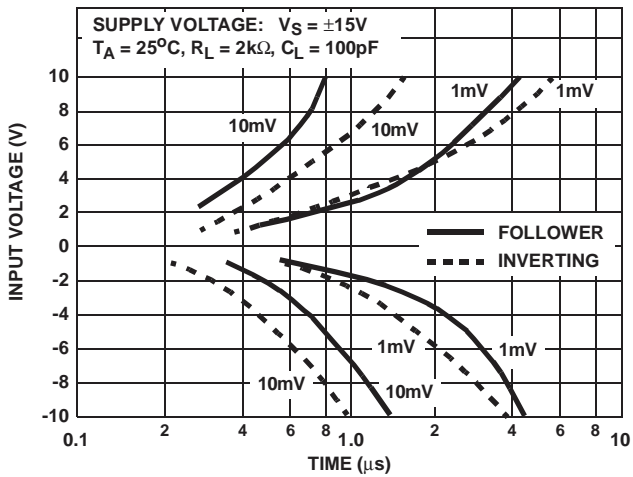

FIGURE 26A. SETTLING TIME vs INPUT VOLTAGE

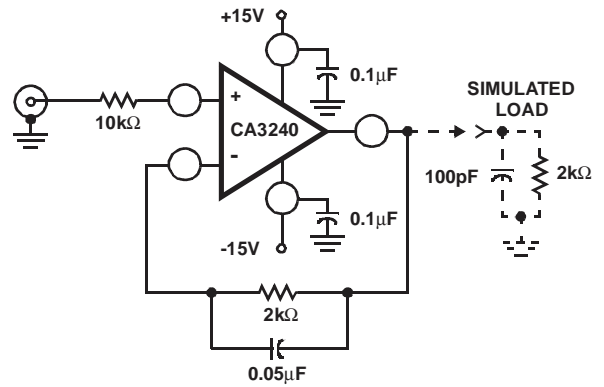

FIGURE 26B. TEST CIRCUIT (FOLLOWER)

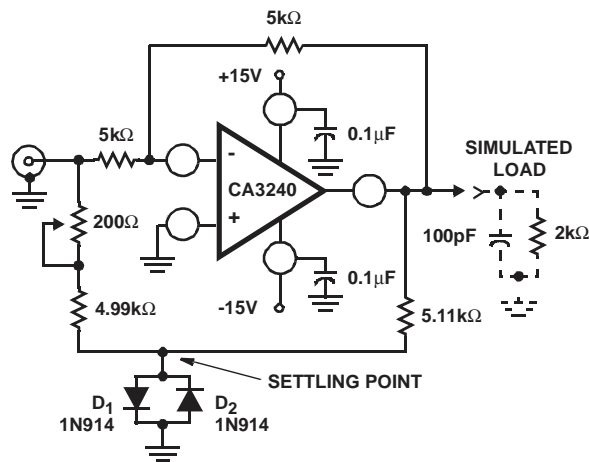

FIGURE 26C. TEST CIRCUIT (INVERTING)

FIGURE 26. INPUT VOLTAGE vs SETTLING TIME

Typical Performance Curves (Continued)

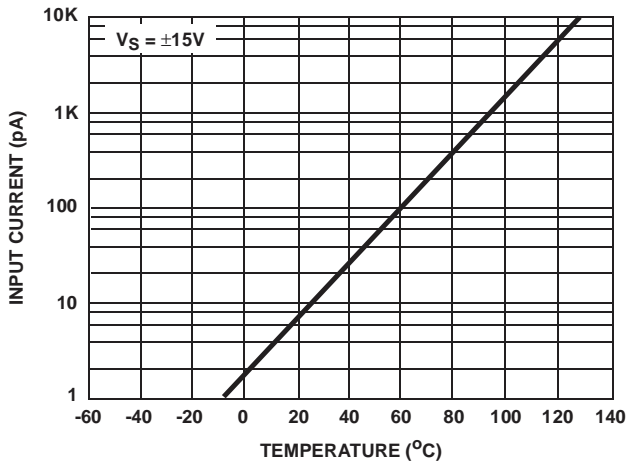

FIGURE 27. INPUT CURRENT vs TEMPERATURE

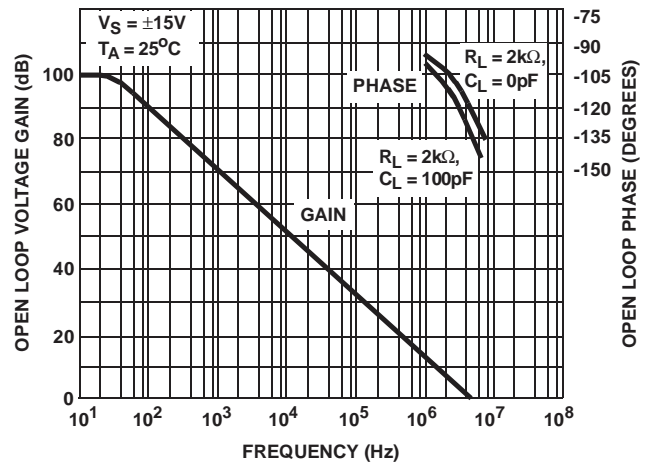

FIGURE 28. OPEN LOOP VOLTAGE GAIN AND PHASE vs FREQUENCY

All Intersil products are manufactured, assembled and tested utilizing ISO9000 quality systems. Intersil Corporation's quality certifications can be viewed at [www.intersil.com/design/quality](http://www.intersil.com/design/quality)

*Intersil products are sold by description only. Intersil Corporation reserves the right to make changes in circuit design and/or specifications at any time without notice. Accordingly, the reader is cautioned to verify that data sheets are current before placing orders. Information furnished by Intersil is believed to be accurate and reliable. However, no responsibility is assumed by Intersil or its subsidiaries for its use; nor for any infringements of patents or other rights of third parties which may result from its use. No license is granted by implication or otherwise under any patent or patent rights of Intersil or its subsidiaries.*

For information regarding Intersil Corporation and its products, see [www.intersil.com](http://www.intersil.com)

**Sales Office Headquarters**

**NORTH AMERICA**

Intersil Corporation  
7585 Irvine Center Drive  
Suite 100  
Irvine, CA 92618  
TEL: (949) 341-7000  
FAX: (949) 341-7123

Intersil Corporation  
2401 Palm Bay Rd.  
Palm Bay, FL 32905  
TEL: (321) 724-7000  
FAX: (321) 724-7946

**EUROPE**

Intersil Europe Sarl  
Ave. C - F Ramuz 43  
CH-1009 Pully  
Switzerland  
TEL: +41 21 7293637  
FAX: +41 21 7293684

**ASIA**

Intersil Corporation  
Unit 1804 18/F Guangdong Water Building  
83 Austin Road  
TST, Kowloon Hong Kong  
TEL: +852 2723 6339  
FAX: +852 2730 1433



LittleDiode supplies new, hard to find or obsolete electronic components and semiconductors all over the world.

With over two million different components listed you are sure to find the part you need.

Feel free to visit us today at our online store:

[LittleDiode.com](http://LittleDiode.com)

Looking forward to providing you with the best possible service.