

## 54157/DM54157/DM74157 Quad 2-Line to 1-Line Data Selectors/Multiplexers

### General Description

These data selectors/multiplexers contain inverters and drivers to supply full on-chip data selection to the four output gates. A separate strobe input is provided. A 4-bit word is selected from one of two sources and is routed to the four outputs.

### Applications

- Expand any data input point
- Multiplex dual data buses
- Generate four functions of two variables (one variable is common)
- Source programmable counters

### Features

- Buffered inputs and outputs
- Typical propagation time 9 ns
- Typical power dissipation 150 mW
- Alternate Military/Aerospace device (54157) is available. Contact a National Semiconductor Sales Office/Distributor for specifications.

### Connection Diagram

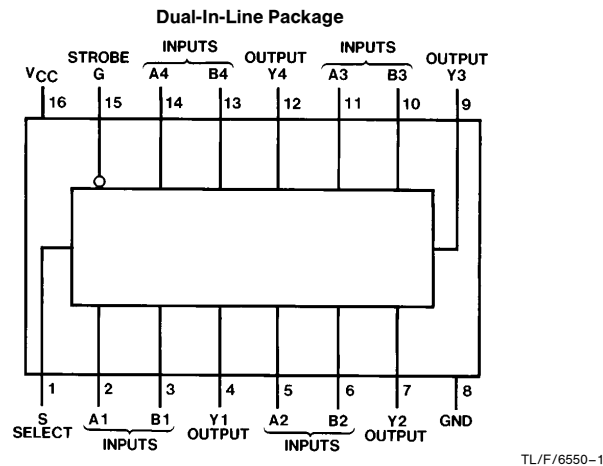

Order Number 54157DMQB, 54157FMQB, DM54157J, DM54157W or DM74157N  
See NS Package Number J16A, N16E or W16A

### Function Table

Inputs				Output Y
Strobe	Select	A	B	
H	X	X	X	L
L	L	L	X	L
L	L	H	X	H
L	H	X	L	L
L	H	X	H	H

H = High Level, L = Low Level, X = Don't Care

## Absolute Maximum Ratings (Note)

If Military/Aerospace specified devices are required, please contact the National Semiconductor Sales Office/Distributors for availability and specifications.

Supply Voltage	7V
Input Voltage	5.5V
Operating Free Air Temperature Range	
DM54 and 54	−55°C to +125°C
DM74	0°C to +70°C
Storage Temperature Range	−65°C to +150°C

Note: The "Absolute Maximum Ratings" are those values beyond which the safety of the device cannot be guaranteed. The device should not be operated at these limits. The parametric values defined in the "Electrical Characteristics" table are not guaranteed at the absolute maximum ratings. The "Recommended Operating Conditions" table will define the conditions for actual device operation.

## Recommended Operating Conditions

Symbol	Parameter	DM54157			DM74157			Units
		Min	Nom	Max	Min	Nom	Max	
V <sub>CC</sub>	Supply Voltage	4.5	5	5.5	4.75	5	5.25	V
V <sub>IH</sub>	High Level Input Voltage	2			2			V
V <sub>IL</sub>	Low Level Input Voltage			0.8			0.8	V
I <sub>OH</sub>	High Level Output Current			−0.8			−0.8	mA
I <sub>OL</sub>	Low Level Output Current			16			16	mA
T <sub>A</sub>	Free Air Operating Temperature	−55		125	0		70	°C

## Electrical Characteristics over recommended operating free air temperature range (unless otherwise noted)

Symbol	Parameter	Conditions	Min	Typ (Note 1)	Max	Units
V <sub>I</sub>	Input Clamp Voltage	V <sub>CC</sub> = Min, I <sub>I</sub> = −12 mA			−1.5	V
V <sub>OH</sub>	High Level Output Voltage	V <sub>CC</sub> = Min, I <sub>OH</sub> = Max V <sub>IL</sub> = Max, V <sub>IH</sub> = Min	2.4	3.4		V
V <sub>OL</sub>	Low Level Output Voltage	V <sub>CC</sub> = Min, I <sub>OL</sub> = Max V <sub>IH</sub> = Min, V <sub>IL</sub> = Max			0.4	V
I <sub>I</sub>	Input Current @ Max Input Voltage	V <sub>CC</sub> = Max, V <sub>I</sub> = 5.5V			1	mA
I <sub>IH</sub>	High Level Input Current	V <sub>CC</sub> = Max, V <sub>I</sub> = 2.4V			40	μA
I <sub>IL</sub>	Low Level Input Current	V <sub>CC</sub> = Max, V <sub>I</sub> = 0.4V			−1.6	mA
I <sub>OS</sub>	Short Circuit Output Current	V <sub>CC</sub> = Max (Note 2)			−55	mA
		DM54	−20		−55	
		DM74	−18		−55	
I <sub>CC</sub>	Supply Current	V <sub>CC</sub> = Max (Note 3)		30	48	mA

Note 1: All typicals are at V<sub>CC</sub> = 5V, T<sub>A</sub> = 25°C.

Note 2: Not more than one output should be shorted at a time.

Note 3: I<sub>CC</sub> is measured with 4.5V applied to all inputs and all outputs open.

**Switching Characteristics** at  $V_{CC} = 5V$  and  $T_A = 25^\circ C$  (See Section 1 for Test Waveforms and Output Load)

Symbol	Parameter	From (Input) To (Output)	$R_L = 400\Omega, C_L = 15\text{ pF}$		Units
			Min	Max	
$t_{PLH}$	Propagation Delay Time Low to High Level Output	Data to Y		14	ns
$t_{PHL}$	Propagation Delay Time High to Low Level Output	Data to Y		14	ns
$t_{PLH}$	Propagation Delay Time Low to High Level Output	Strobe to Y		20	ns
$t_{PHL}$	Propagation Delay Time High to Low Level Output	Strobe to Y		21	ns
$t_{PLH}$	Propagation Delay Time Low to High Level Output	Select to Y		23	ns
$t_{PHL}$	Propagation Delay Time High to Low Level Output	Select to Y		27	ns

**Logic Diagram**

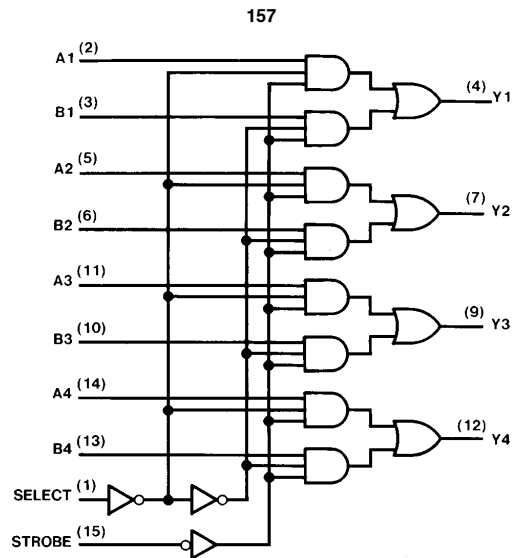

TL/F/6550-2



**Physical Dimensions** inches (millimeters)

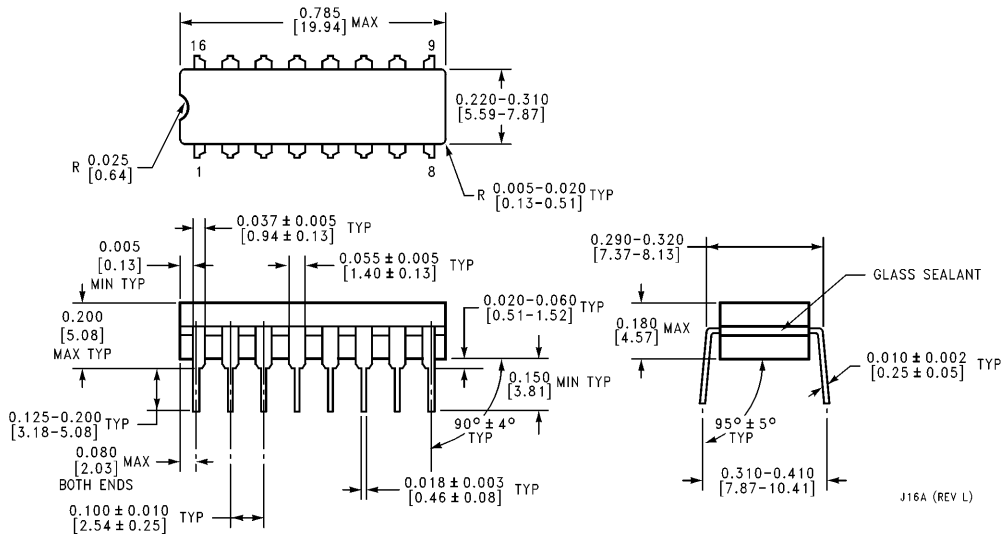

**16-Lead Ceramic Dual-In-Line Package (J)**  
**Order Number 54157W or DM54157J**  
**NS Package Number J16A**

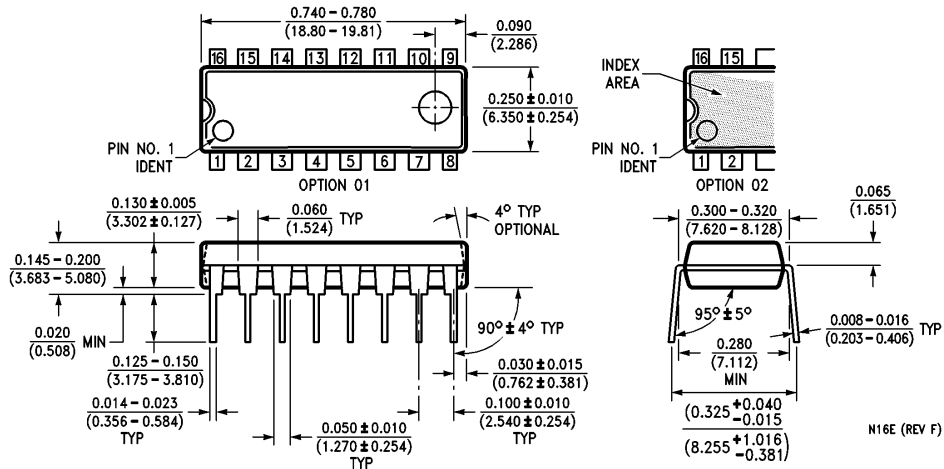

**16-Lead Molded Dual-In-Line Package (N)**  
**Order Number DM74157N**  
**NS Package Number N16E**

**Physical Dimensions** inches (millimeters) (Continued)

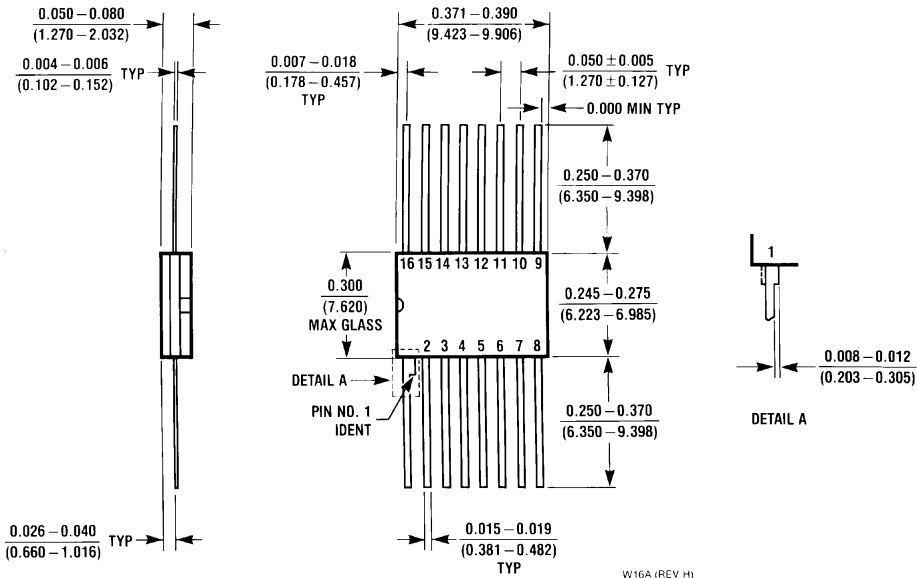

**16-Lead Ceramic Flat Package (W)**  
**Order Number 54157FMQB or DM54157W**  
**NS Package Number W16A**

**LIFE SUPPORT POLICY**

NATIONAL'S PRODUCTS ARE NOT AUTHORIZED FOR USE AS CRITICAL COMPONENTS IN LIFE SUPPORT DEVICES OR SYSTEMS WITHOUT THE EXPRESS WRITTEN APPROVAL OF THE PRESIDENT OF NATIONAL SEMICONDUCTOR CORPORATION. As used herein:

1. Life support devices or systems are devices or systems which, (a) are intended for surgical implant into the body, or (b) support or sustain life, and whose failure to perform, when properly used in accordance with instructions for use provided in the labeling, can be reasonably expected to result in a significant injury to the user.
2. A critical component is any component of a life support device or system whose failure to perform can be reasonably expected to cause the failure of the life support device or system, or to affect its safety or effectiveness.



**National Semiconductor Corporation**  
 1111 West Bardin Road  
 Arlington, TX 76017  
 Tel: 1(800) 272-9959  
 Fax: 1(800) 737-7018

**National Semiconductor Europe**  
 Fax: (+49) 0-180-530 85 86  
 Email: onjwge@tevm2.nsc.com  
 Deutsch Tel: (+49) 0-180-530 85 85  
 English Tel: (+49) 0-180-532 78 32  
 Français Tel: (+49) 0-180-532 93 58  
 Italiano Tel: (+49) 0-180-534 16 80

**National Semiconductor Hong Kong Ltd.**  
 13th Floor, Straight Block,  
 Ocean Centre, 5 Canton Rd.  
 Tsimshatsui, Kowloon  
 Hong Kong  
 Tel: (852) 2737-1600  
 Fax: (852) 2736-9960

**National Semiconductor Japan Ltd.**  
 Tel: 81-043-299-2309  
 Fax: 81-043-299-2408

National does not assume any responsibility for use of any circuitry described, no circuit patent licenses are implied and National reserves the right at any time without notice to change said circuitry and specifications.

This datasheet has been downloaded from:

[www.DatasheetCatalog.com](http://www.DatasheetCatalog.com)

Datasheets for electronic components.

# National Semiconductor was acquired by Texas Instruments.

[http://www.ti.com/corp/docs/investor\\_relations/pr\\_09\\_23\\_2011\\_national\\_semiconductor.html](http://www.ti.com/corp/docs/investor_relations/pr_09_23_2011_national_semiconductor.html)

This file is the datasheet for the following electronic components:

54157FMQB - <http://www.ti.com/product/54157fmqb?HQS=TI-null-null-dscatalog-df-pf-null-wwe>

DM74157N - <http://www.ti.com/product/dm74157n?HQS=TI-null-null-dscatalog-df-pf-null-wwe>

74157 - <http://www.ti.com/product/74157?HQS=TI-null-null-dscatalog-df-pf-null-wwe>

DM54157J - <http://www.ti.com/product/dm54157j?HQS=TI-null-null-dscatalog-df-pf-null-wwe>

54157DMQB - <http://www.ti.com/product/54157dmqb?HQS=TI-null-null-dscatalog-df-pf-null-wwe>

DM54157W - <http://www.ti.com/product/dm54157w?HQS=TI-null-null-dscatalog-df-pf-null-wwe>



LittleDiode supplies new, hard to find or obsolete electronic components and semiconductors all over the world.

With over two million different components listed you are sure to find the part you need.

Feel free to visit us today at our online store:

[LittleDiode.com](http://LittleDiode.com)

Looking forward to providing you with the best possible service.