



Not recommended for new designs –
Please use 93LC46C, 93LC56C or 93LC66C.

93LC46/56/66

1K/2K/4K 2.5V Microwire Serial EEPROM

Features:

- Single supply with programming operation down to 2.5V
- Low-power CMOS technology
- 100 μ A typical active read current at 2.5V
- 3 μ A typical standby current at 2.5V
- ORG pin selectable memory configuration
- 128 x 8- or 64 x 16-bit organization (93LC46)
- 256 x 8- or 128 x 16-bit organization (93LC56)
- 512 x 8 or 256 x 16 bit organization (93LC66)
- Self-timed erase and write cycles (including auto-erase)
- Automatic ERAL before WRAL
- Power on/off data protection circuitry
- Industry standard 3-wire serial I/O
- Device status signal during erase/write cycles
- Sequential read function
- 1,000,000 E/W cycles ensured
- Data retention > 200 years
- 8-pin PDIP/SOIC (SOIC in JEDEC standards)
- Temperature ranges supported:
 - Industrial (I): -40°C to +85°C

Description:

The Microchip Technology Inc. 93LC46/56/66 are 1K, 2K and 4K low voltage serial Electrically Erasable PROMs (EEPROM). The device memory is configured as x8 or x16 bits depending on the external logic of levels of the ORG pin. Advanced CMOS technology makes these devices ideal for low power nonvolatile memory applications. The 93LC Series is available in standard 8-pin PDIP and surface mount SOIC packages. The rotated pin-out 93LC46X/56X/66X are offered in the "SN" package only.

Package Types

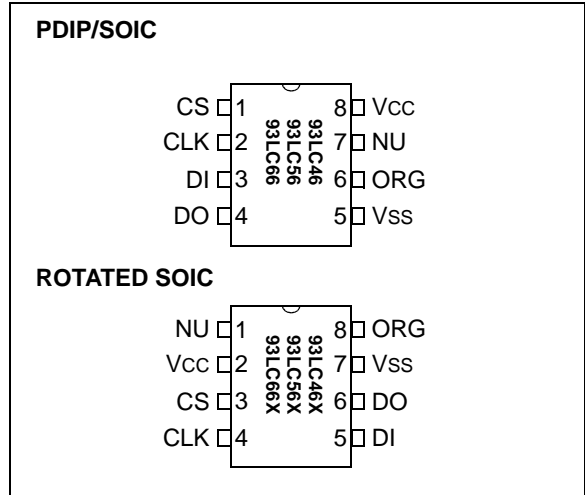

Block Diagram

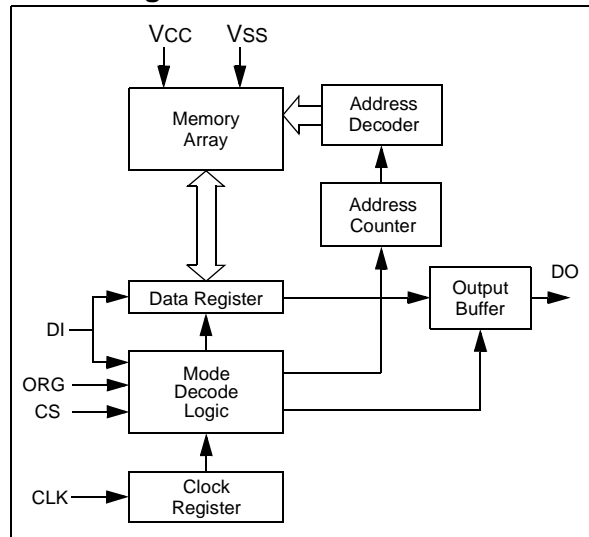

93LC46/56/66

1.0 ELECTRICAL CHARACTERISTICS

Absolute Maximum Ratings^(†)

V _{CC}	6.5V
All inputs and outputs w.r.t. V _{SS}	-0.6V to V _{CC} + 1.0V
Storage temperature	-65°C to +150°C
Ambient temperature with power applied.....	-40°C to +125°C
ESD protection on all pins	≥ 4 kV

† **NOTICE:** Stresses above those listed under "Maximum ratings" may cause permanent damage to the device. This is a stress rating only and functional operation of the device at those or any other conditions above those indicated in the operational listings of this specification is not implied. Exposure to maximum rating conditions for extended periods may affect device reliability.

DC CHARACTERISTICS

DC CHARACTERISTICS			V _{CC} = +2.5V to +5.5V Industrial (I): T _A = -40°C to +85°C				
Param. No.	Sym	Characteristic	Min	Typ	Max	Units	Conditions
D1	V _{IH1}	High-level input voltage	2.0	—	V _{CC} +1	V	V _{CC} ≥ 2.7V
	V _{IH2}		0.7 V _{CC}	—	V _{CC} +1	V	V _{CC} ≥ 2.7V
D2	V _{IL1}	Low-level input voltage	-0.3	—	0.8	V	V _{CC} ≥ 2.7V
	V _{IL2}		-0.3	—	0.2 V _{CC}	V	V _{CC} ≥ 2.7V
D3	V _{OL1}	Low-level output voltage	—	—	0.4	V	I _{OL} = 2.1 mA, V _{CC} = 4.5V
	V _{OL2}		—	—	0.3	V	I _{OL} = 100 μA, V _{CC} = 2.5V
D4	V _{OH1}	High-level output voltage	2.4	—	—	V	I _{OL} = 400 μA, V _{CC} = 4.5V
	V _{OH2}		V _{CC} -0.2	—	—	V	I _{OL} = 100 μA, V _{CC} = 2.5V
D5	I _{LI}	Input leakage current	—	—	±10	μA	V _{IN} = 0.1V to V _{CC}
D6	I _{LO}	Output leakage current	—	—	±10	μA	V _{OUT} = 0.1V to V _{CC}
D7	C _{IN} , C _{OUT}	Pin capacitance (all inputs/outputs)	—	—	7	pF	V _{IN} /V _{OUT} = 0V (Note 1 & 2) T _A = 25°C, F _{CLK} = 1 MHz
D8	I _{CC} write	Operating current	—	—	3	mA	F _{CLK} = 2 MHz, V _{CC} = 5.5V (Note 2)
D9	I _{CC} read		—	—	1	mA	F _{CLK} = 2 MHz, V _{CC} = 5.5V
			—	—	500	μA	F _{CLK} = 1 MHz, V _{CC} = 3.0V
D10	I _{CCS}	—	—	—	μA	F _{CLK} = 1 MHz, V _{CC} = 2.5V	
		—	—	100	μA	CLK = CS = 0V; V _{CC} = 5.5V	
		—	3	—	μA	CLK = CS = 0V; V _{CC} = 3.0V CLK = CS = 0V; V _{CC} = 2.5V ORG, DI = V _{SS} or V _{CC}	

Note 1: This parameter is tested at T_A = 25°C and F_{CLK} = 1 MHz.

2: This parameter is periodically sampled and not 100% tested.

AC CHARACTERISTICS

AC CHARACTERISTICS			VCC = +2.5V to +5.5V Industrial (I): TA = -40°C to +85°C				
Param. No.	Sym	Characteristic	Min	Typ	Max	Units	Conditions
1	FCLK	Clock frequency	—	—	2	MHz	VCC ≥ 4.5V
			—	—	1	MHz	VCC < 4.5V
2	TCKH	Clock high time	250	—	—	ns	
3	TCKL	Clock low time	250	—	—	ns	
4	TCSS	Chip select setup time	50	—	—	ns	Relative to CLK
5	TCSH	Chip select hold time	0	—	—	ns	Relative to CLK
6	TCSL	Chip select low time	250	—	—	ns	
7	TDIS	Data input setup time	100	—	—	ns	Relative to CLK
8	TDIH	Data input hold time	100	—	—	ns	Relative to CLK
9	TPD	Data output delay time	—	—	400	ns	CL = 100 pF
10	TCZ	Data output disable time	—	—	100	ns	CL = 100 pf (Note 2)
11	Tsv	Status valid time	—	—	500	ns	CL = 100 pF
12	TWC	Program cycle time	—	4	10	ms	Erase/Write mode
13	TEC		—	8	15	ms	ERAL mode (VCC=5V ±10%)
14	TWL		—	16	30	ms	WRAL mode (VCC=5V ±10%)
15	—	Endurance	1M	—	1M	cycles	25°C, VCC = 5.0V, Block mode (Note 3)

Note 1: This parameter is tested at TA = 25°C and FCLK = 1 MHz.

2: This parameter is periodically sampled and not 100% tested.

3: This parameter is not tested but ensured by characterization. For endurance estimates in a specific application, please consult the Total Endurance™ Model which can be obtained from Microchip's web site at: www.microchip.com.

FIGURE 1-1: SYNCHRONOUS DATA TIMING

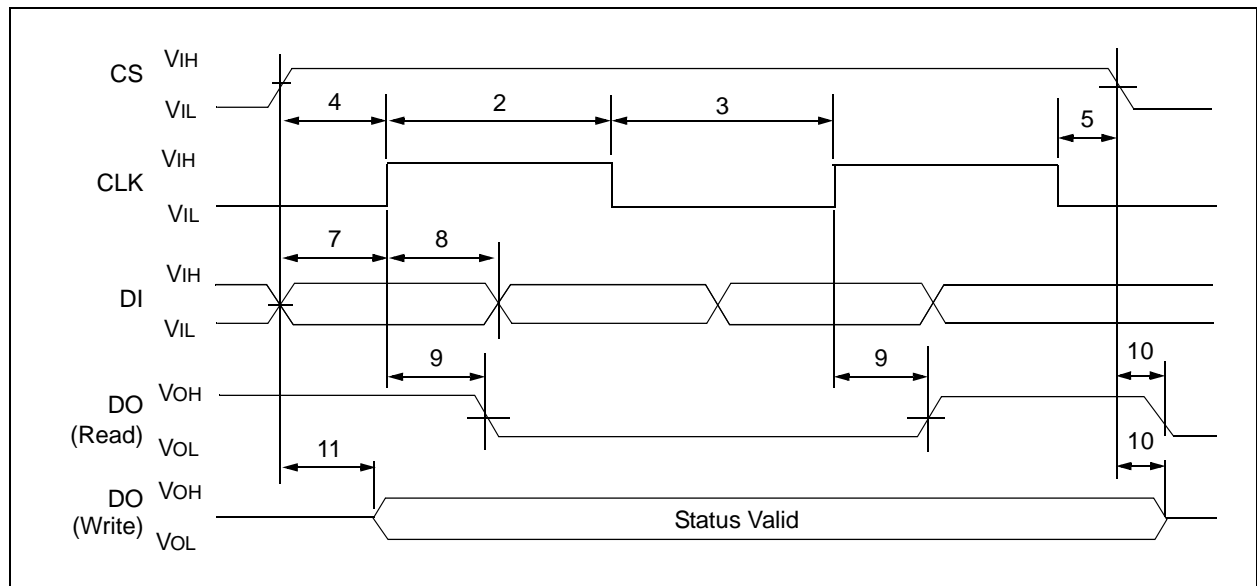

93LC46/56/66

TABLE 1-1: INSTRUCTION SET FOR 93LC46: ORG = 1 (X 16 ORGANIZATION)

Instruction	SB	Opcode	Address	Data In	Data Out	Req. CLK Cycles
READ	1	10	A5 A4 A3 A2 A1 A0	—	D15 - D0	25
EWEN	1	00	1 1 XXXX	—	High-Z	9
ERASE	1	11	A5 A4 A3 A2 A1 A0	—	(RDY/BSY)	9
ERAL	1	00	1 0 XXXX	—	(RDY/BSY)	9
WRITE	1	01	A5 A4 A3 A2 A1 A0	D15 - D0	(RDY/BSY)	25
WRAL	1	00	0 1 XXXX	D15 - D0	(RDY/BSY)	25
EWDS	1	00	0 0 XXXX	—	High-Z	9

TABLE 1-2: INSTRUCTION SET FOR 93LC46: ORG = 0 (X 8 ORGANIZATION)

Instruction	SB	Opcode	Address	Data In	Data Out	Req. CLK Cycles
READ	1	10	A6 A5 A4 A3 A2 A1 A0	—	D7 - D0	18
EWEN	1	00	1 1 X X X X X	—	High-Z	10
ERASE	1	11	A6 A5 A4 A3 A2 A1 A0	—	(RDY/BSY)	10
ERAL	1	00	1 0 X X X X X	—	(RDY/BSY)	10
WRITE	1	01	A6 A5 A4 A3 A2 A1 A0	D7 - D0	(RDY/BSY)	18
WRAL	1	00	0 1 X X X X X	D7 - D0	(RDY/BSY)	18
EWDS	1	00	0 0 X X X X X	—	High-Z	10

TABLE 1-3: INSTRUCTION SET FOR 93LC56: ORG = 1 (X 16 ORGANIZATION)

Instruction	SB	Opcode	Address	Data In	Data Out	Req. CLK Cycles
READ	1	10	X A6 A5 A4 A3 A2 A1 A0	—	D15 - D0	27
EWEN	1	00	1 1 X X X X X X	—	High-Z	11
ERASE	1	11	X A6 A5 A4 A3 A2 A1 A0	—	(RDY/BSY)	11
ERAL	1	00	1 0 X X X X X X	—	(RDY/BSY)	11
WRITE	1	01	X A6 A5 A4 A3 A2 A1 A0	D15 - D0	(RDY/BSY)	27
WRAL	1	00	0 1 X X X X X X	D15 - D0	(RDY/BSY)	27
EWDS	1	00	0 0 X X X X X X	—	High-Z	11

TABLE 1-4: INSTRUCTION SET FOR 93LC56: ORG = 0 (X 8 ORGANIZATION)

Instruction	SB	Opcode	Address	Data In	Data Out	Req. CLK Cycles
READ	1	10	X A7 A6 A5 A4 A3 A2 A1 A0	—	D7 - D0	20
EWEN	1	00	1 1 X X X X X X X	—	High-Z	12
ERASE	1	11	X A7 A6 A5 A4 A3 A2 A1 A0	—	(RDY/BSY)	12
ERAL	1	00	1 0 X X X X X X X	—	(RDY/BSY)	12
WRITE	1	01	X A7 A6 A5 A4 A3 A2 A1 A0	D7 - D0	(RDY/BSY)	20
WRAL	1	00	0 1 X X X X X X X	D7 - D0	(RDY/BSY)	20
EWDS	1	00	0 0 X X X X X X X	—	High-Z	12

TABLE 1-5: INSTRUCTION SET FOR 93LC66: ORG = 1 (X 16 ORGANIZATION)

Instruction	SB	Opcode	Address	Data In	Data Out	Req. CLK Cycles
READ	1	10	A7 A6 A5 A4 A3 A2 A1 A0	—	D15 - D0	27
EWEN	1	00	1 1 X X X X X X	—	High-Z	11
ERASE	1	11	A7 A6 A5 A4 A3 A2 A1 A0	—	(RDY/BSY)	11
ERAL	1	00	1 0 X X X X X X	—	(RDY/BSY)	11
WRITE	1	01	A7 A6 A5 A4 A3 A2 A1 A0	D15 - D0	(RDY/BSY)	27
WRAL	1	00	0 1 X X X X X X	D15 - D0	(RDY/BSY)	27
EWDS	1	00	0 0 X X X X X X	—	High-Z	11

TABLE 1-6: INSTRUCTION SET FOR 93LC66: ORG = 0 (X 8 ORGANIZATION)

Instruction	SB	Opcode	Address	Data In	Data Out	Req. CLK Cycles
READ	1	10	A8 A7 A6 A5 A4 A3 A2 A1 A0	—	D7 - D0	20
EWEN	1	00	1 1 X X X X X X X	—	High-Z	12
ERASE	1	11	A8 A7 A6 A5 A4 A3 A2 A1 A0	—	(RDY/BSY)	12
ERAL	1	00	1 0 X X X X X X X	—	(RDY/BSY)	12
WRITE	1	01	A8 A7 A6 A5 A4 A3 A2 A1 A0	D7 - D0	(RDY/BSY)	20
WRAL	1	00	0 1 X X X X X X X	D7 - D0	(RDY/BSY)	20
EWDS	1	00	0 0 X X X X X X X	—	High-Z	12

2.0 FUNCTIONAL DESCRIPTION

When the ORG pin is connected to VCC, the (x16) organization is selected. When it is connected to ground, the (x8) organization is selected. Instructions, addresses and write data are clocked into the DI pin on the rising edge of the clock (CLK). The DO pin is normally held in a high-Z state except when reading data from the device, or when checking the Ready/Busy status during a programming operation. The Ready/Busy status can be verified during an erase/write operation by polling the DO pin; DO low indicates that programming is still in progress, while DO high indicates the device is ready. The DO will enter the high-Z state on the falling edge of the CS.

2.1 Start Condition

The Start bit is detected by the device if CS and DI are both high with respect to the positive edge of CLK for the first time.

Before a Start condition is detected, CS, CLK and DI may change in any combination (except to that of a Start condition), without resulting in any device operation (Read, Write, Erase, EWEN, EWDS, ERAL and WRAL). As soon as CS is high, the device is no longer in the Standby mode.

An instruction following a Start condition will only be executed if the required amount of opcode, address and data bits for any particular instruction is clocked in.

After execution of an instruction (i.e., clock in or out of the last required address or data bit) CLK and DI become “don't care” bits until a new Start condition is detected.

2.2 Data In/Data Out (DI/DO)

It is possible to connect the Data In and Data Out pins together. However, with this configuration it is possible for a “bus conflict” to occur during the “dummy zero” that precedes the read operation, if A0 is a logic high level. Under such a condition the voltage level seen at Data Out is undefined and will depend upon the relative impedances of Data Out and the signal source driving A0. The higher the current sourcing capability of A0, the higher the voltage at the Data Out pin.

2.3 Data Protection

During power-up, all programming modes of operation are inhibited until VCC has reached a level greater than 1.4V. During power-down, the source data protection circuitry acts to inhibit all programming modes when VCC has fallen below 1.4V at nominal conditions.

The EWEN and EWDS commands give additional protection against accidentally programming during normal operation.

After power-up, the device is automatically in the EWDS mode. Therefore, an EWEN instruction must be performed before any ERASE or WRITE instruction can be executed.

2.4 Read

The READ instruction outputs the serial data of the addressed memory location on the DO pin. A dummy zero bit precedes the 16-bit (x16 organization) or 8-bit (x8 organization) output string. The output data bits will toggle on the rising edge of the CLK and are stable after the specified time delay (TPD). Sequential read is possible when CS is held high. The memory data will automatically cycle to the next register and output sequentially.

2.5 Erase/Write Enable and Disable (EWEN, EWDS)

The 93LC46/56/66 power up in the Erase/Write Disable (EWDS) state. All programming modes must be preceded by an Erase/Write Enable (EWEN) instruction. Once the EWEN instruction is executed, programming remains enabled until an EWDS instruction is executed or VCC is removed from the device. To protect against accidental data disturb, the EWDS instruction can be used to disable all erase/write functions and should follow all programming operations. Execution of a READ instruction is independent of both the EWEN and EWDS instructions.

2.6 Erase

The ERASE instruction forces all data bits of the specified address to the logical “1” state. CS is brought low following the loading of the last address bit. This falling edge of the CS pin initiates the self-timed programming cycle.

The DO pin indicates the Ready/Busy status of the device if CS is brought high after a minimum of 250 ns low (TCSL). DO at logical “0” indicates that programming is still in progress. DO at logical “1” indicates that the register at the specified address has been erased and the device is ready for another instruction.

The erase cycle takes 4 ms per word typical.

2.7 Write

The `WRITE` instruction is followed by 16 bits (or by 8 bits) of data which are written into the specified address. After the last data bit is put on the DI pin, CS must be brought low before the next rising edge of the CLK clock. This falling edge of CS initiates the self-timed auto-erase and programming cycle.

The DO pin indicates the Ready/ $\overline{\text{Busy}}$ status of the device if CS is brought high after a minimum of 250 ns low (TCSL) and before the entire write cycle is complete. DO at logical "0" indicates that programming is still in progress. DO at logical "1" indicates that the register at the specified address has been written with the data specified and the device is ready for another instruction.

The write cycle takes 4 ms per word typical.

2.8 Erase All (ERAL)

The `ERAL` instruction will erase the entire memory array to the logical "1" state. The `ERAL` cycle is identical to the `ERASE` cycle except for the different opcode. The `ERAL` cycle is completely self-timed and commences at the falling edge of the CS. Clocking of the CLK pin is not necessary after the device has entered the self clocking mode. The `ERAL` instruction is ensured at 5V $\pm 10\%$.

The DO pin indicates the Ready/ $\overline{\text{Busy}}$ status of the device if CS is brought high after a minimum of 250 ns low (TCSL) and before the entire write cycle is complete.

The `ERAL` cycle takes (8 ms typical).

2.9 Write All (WRAL)

The `WRAL` instruction will write the entire memory array with the data specified in the command. The `WRAL` cycle is completely self-timed and commences at the falling edge of the CS. Clocking of the CLK pin is not necessary after the device has entered the self clocking mode. The `WRAL` command does include an automatic `ERAL` cycle for the device. Therefore, the `WRAL` instruction does not require an `ERAL` instruction but the chip must be in the `EWEN` status. The `WRAL` instruction is ensured at 5V $\pm 10\%$.

The DO pin indicates the Ready/ $\overline{\text{Busy}}$ status of the device if CS is brought high after a minimum of 250 ns low (TCSL).

The `WRAL` cycle takes 16 ms typical.

FIGURE 2-1: READ TIMING

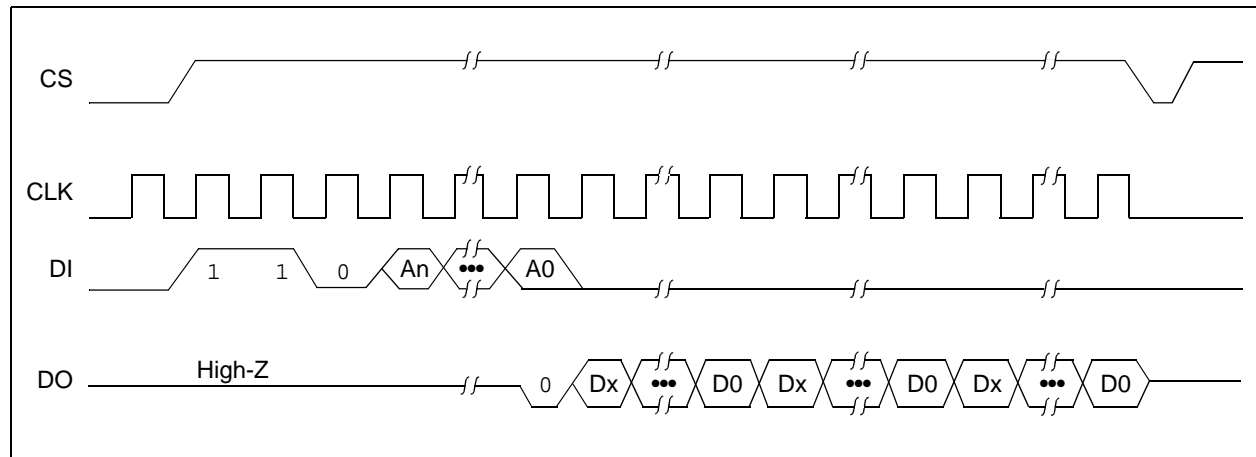

93LC46/56/66

FIGURE 2-2: EWEN TIMING

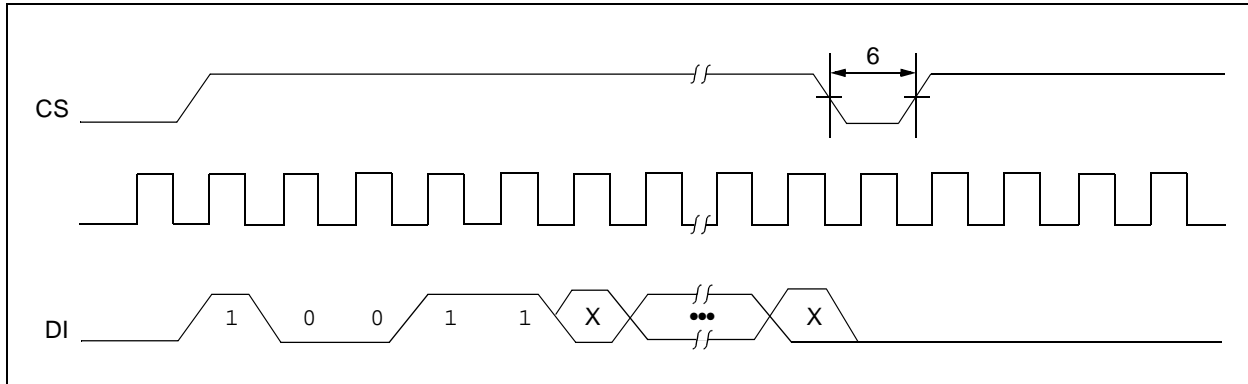

FIGURE 2-3: EWDS TIMING

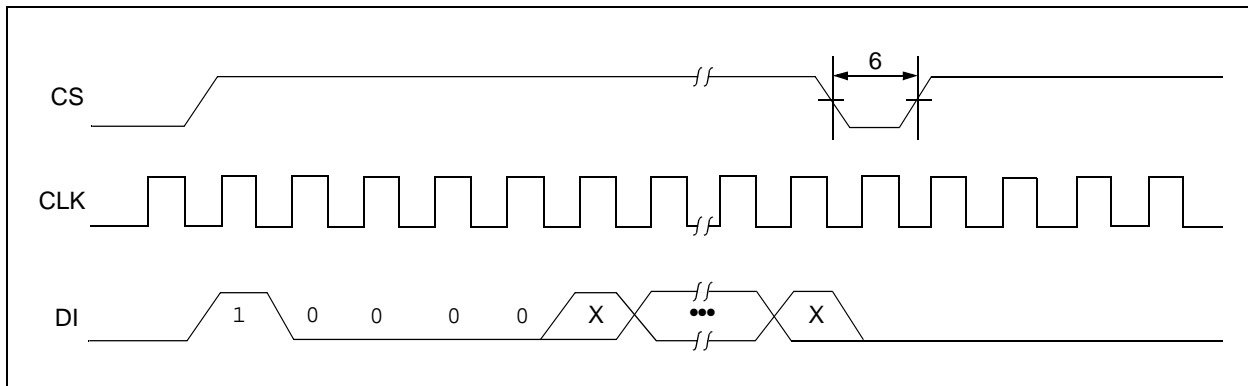

FIGURE 2-4: WRITE TIMING

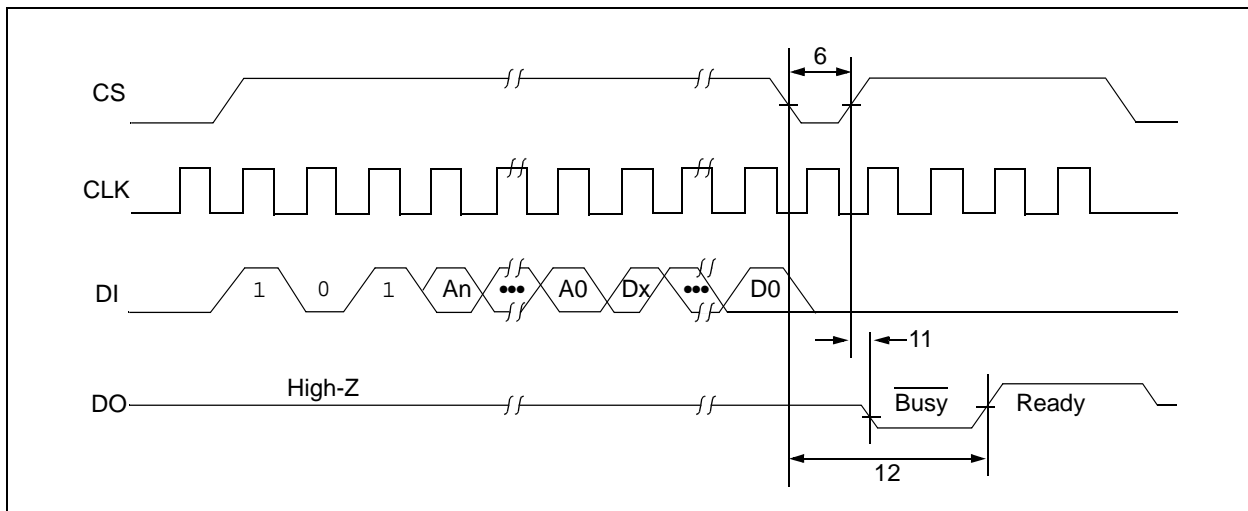

FIGURE 2-5: WRAL TIMING

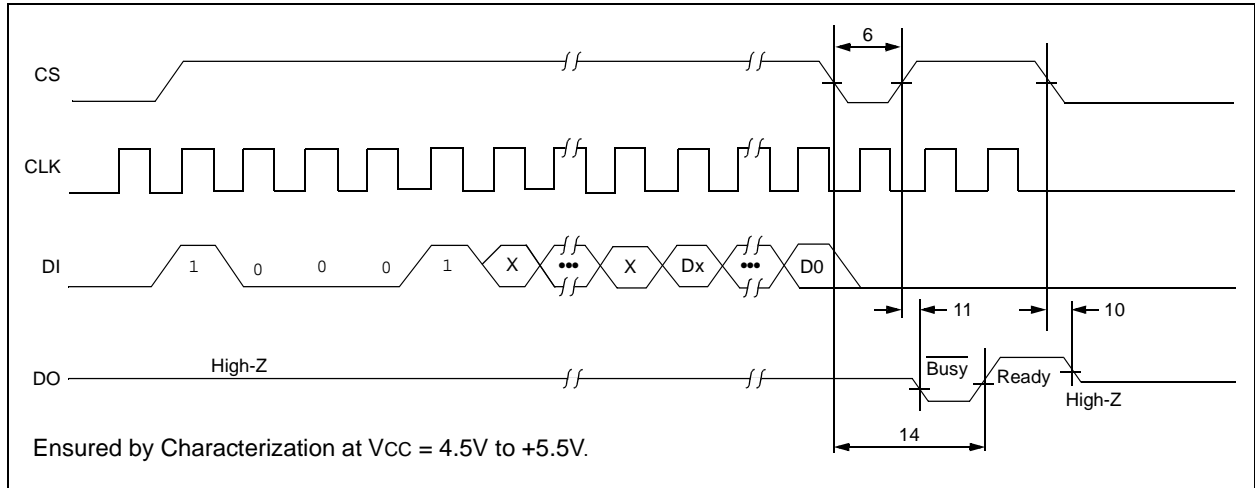

FIGURE 2-6: ERASE TIMING

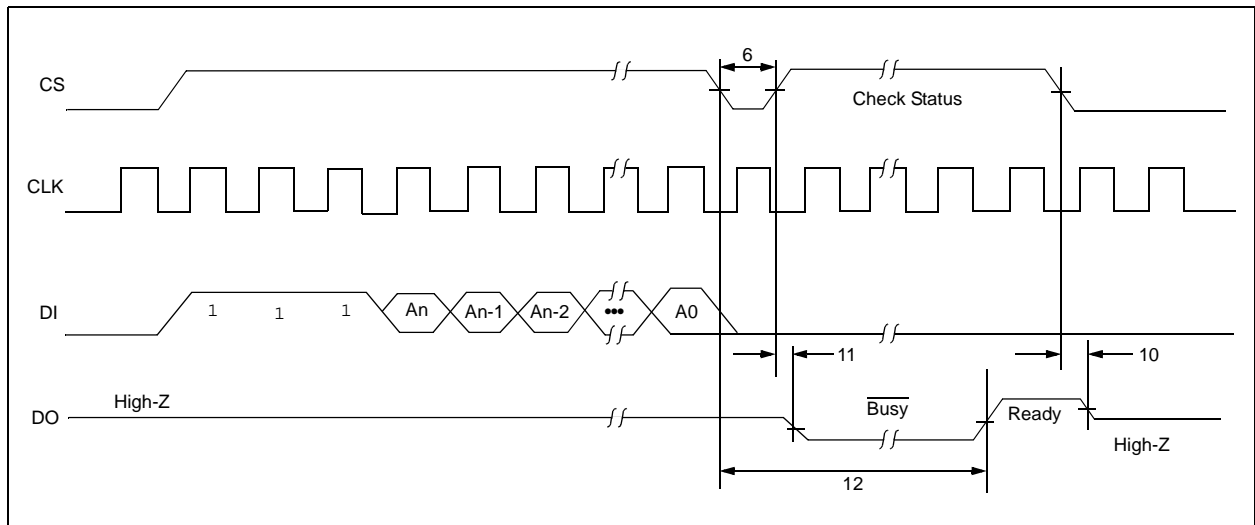
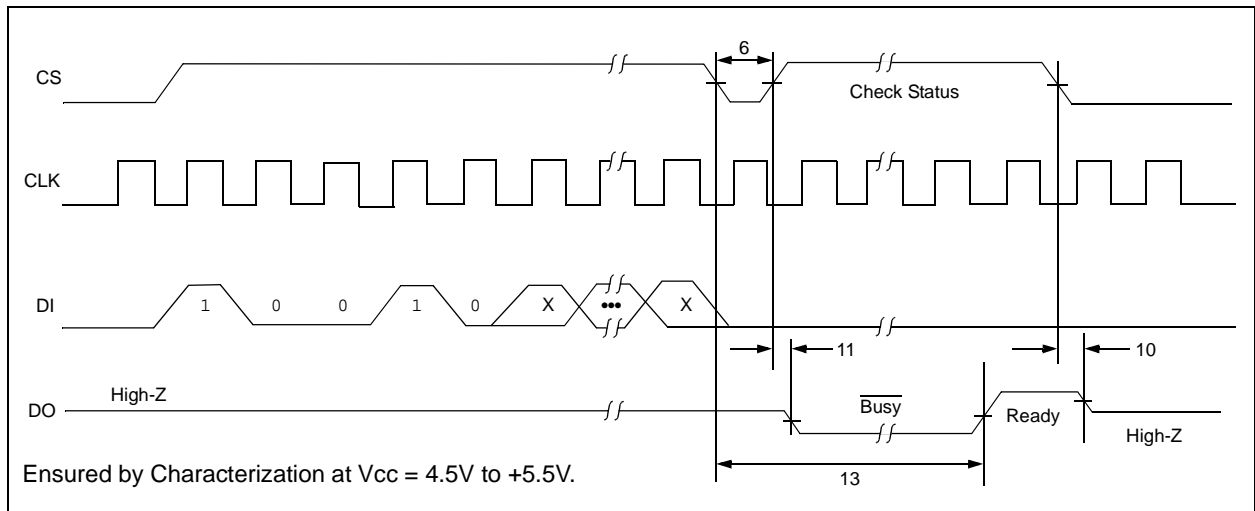

FIGURE 2-7: ERAL TIMING



93LC46/56/66

3.0 PIN DESCRIPTION

The descriptions of the pins are listed in Table 3-1.

TABLE 3-1: PIN FUNCTION TABLE

Name	PDIP	SOIC	ROTATED TSSOP	Description
CS	1	1	3	Chip Select
CLK	2	2	4	Serial Data Clock
DI	3	3	5	Serial Data Input
DO	4	4	6	Serial Data Output
Vss	5	5	7	Ground
ORG	6	6	8	Memory Configuration
NU	7	7	1	Not Utilized
Vcc	8	8	2	+1.8V to 5.5V Power Supply

3.1 Chip Select (CS)

A high level selects the device. A low level deselects the device and forces it into Standby mode. However, a programming cycle which is already initiated and/or in progress will be completed, regardless of the CS input signal. If CS is brought low during a program cycle, the device will go into Standby mode as soon as the programming cycle is completed.

CS must be low for 250 ns minimum (T_{CSL}) between consecutive instructions. If CS is low, the internal control logic is held in a Reset status.

3.2 Serial Clock (CLK)

The serial clock is used to synchronize the communication between a master device and the 93LC46/56/66. Opcode, address and data bits are clocked in on the positive edge of CLK. Data bits are also clocked out on the positive edge of CLK.

CLK can be stopped anywhere in the transmission sequence (at high or low level) and can be continued anytime with respect to clock high time (T_{CKH}) and clock low time (T_{CKL}). This gives the controlling master freedom in preparing opcode, address and data.

CLK is a “don't care” if CS is low (device deselected). If CS is high, but Start condition has not been detected, any number of clock cycles can be received by the device without changing its status (i.e., waiting for Start condition).

CLK cycles are not required during the self-timed write (i.e., auto erase/write) cycle.

After detection of a Start condition the specified number of clock cycles (respectively low-to-high transitions of CLK) must be provided. These clock cycles are required to clock in all required opcode, address and data bits before an instruction is executed (see instruction set truth table). CLK and DI then become “don't care” inputs waiting for a new Start condition to be detected.

Note: CS must go low between consecutive instructions.

3.3 Data In (DI)

Data In is used to clock in a Start bit, opcode, address and data synchronously with the CLK input.

3.4 Data Out (DO)

Data Out is used in the Read mode to output data synchronously with the CLK input (T_{PD} after the positive edge of CLK).

This pin also provides Ready/Busy status information during erase and write cycles. Ready/Busy status information is available on the DO pin if CS is brought high after being low for minimum chip select low time (T_{CSL}) and an erase or write operation has been initiated.

The Status signal is not available on DO, if CS is held low or high during the entire write or erase cycle. In all other cases DO is in the High-Z mode. If status is checked after the write/erase cycle, a pull-up resistor on DO is required to read the Ready signal.

3.5 Organization (ORG)

When ORG is connected to V_{CC}, the (x16) memory organization is selected. When ORG is tied to V_{SS}, the (x8) memory organization is selected. ORG can only be floated for clock speeds of 1 MHz or less for the (x16) memory organization. For clock speeds greater than 1 MHz, ORG must be tied to V_{CC} or V_{SS}.

4.0 PACKAGING INFORMATION

4.1 Package Marking Information

8-Lead PDIP (300 mil)

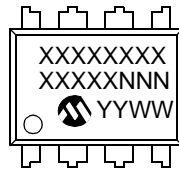

Example:

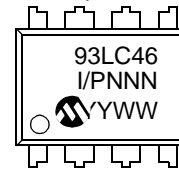

8-Lead SOIC (150 mil)

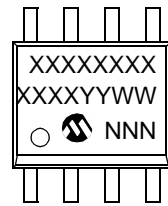

Example:

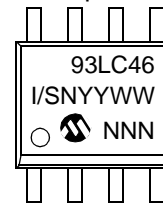

8-Lead Rotated SOIC (150 mil)

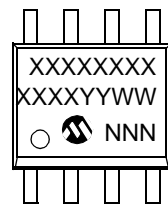

Example:

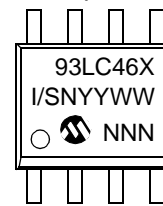

Legend:	XX...X	Customer specific information*
	YY	Year code (last 2 digits of calendar year)
	WW	Week code (week of January 1 is week '01')
	NNN	Alphanumeric traceability code
Note:	In the event the full Microchip part number cannot be marked on one line, it will be carried over to the next line thus limiting the number of available characters for customer specific information.	

* Standard OTP marking consists of Microchip part number, year code, week code, and traceability code.

93LC46/56/66

8-Lead Plastic Dual In-line (P) – 300 mil (PDIP)

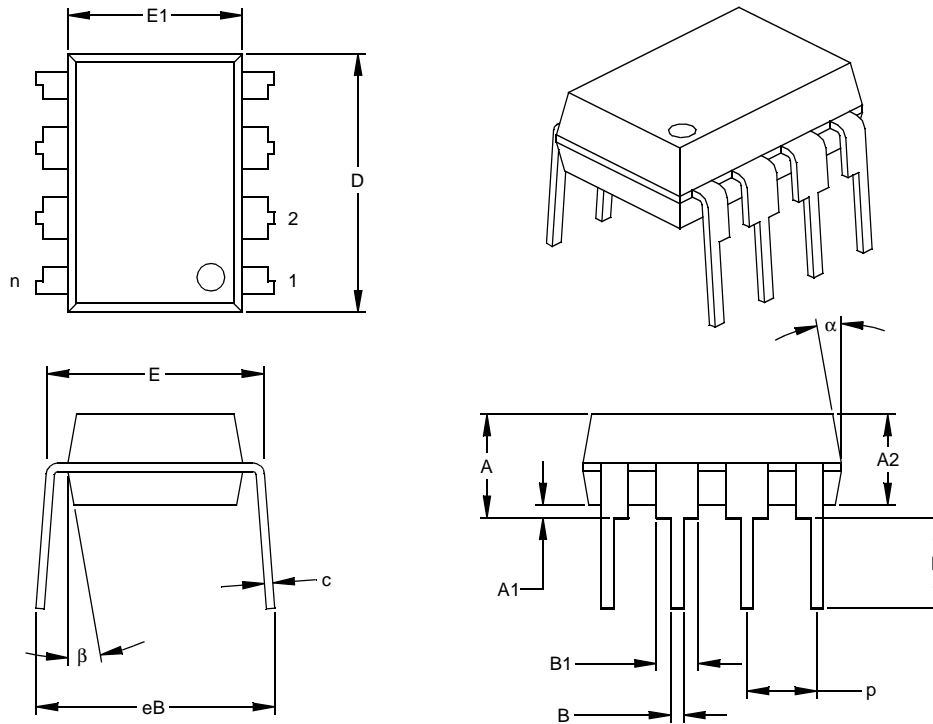

Dimension Limits	Units	INCHES*			MILLIMETERS		
		MIN	NOM	MAX	MIN	NOM	MAX
Number of Pins	n		8			8	
Pitch	p		.100			2.54	
Top to Seating Plane	A	.140	.155	.170	3.56	3.94	4.32
Molded Package Thickness	A2	.115	.130	.145	2.92	3.30	3.68
Base to Seating Plane	A1	.015			0.38		
Shoulder to Shoulder Width	E	.300	.313	.325	7.62	7.94	8.26
Molded Package Width	E1	.240	.250	.260	6.10	6.35	6.60
Overall Length	D	.360	.373	.385	9.14	9.46	9.78
Tip to Seating Plane	L	.125	.130	.135	3.18	3.30	3.43
Lead Thickness	c	.008	.012	.015	0.20	0.29	0.38
Upper Lead Width	B1	.045	.058	.070	1.14	1.46	1.78
Lower Lead Width	B	.014	.018	.022	0.36	0.46	0.56
Overall Row Spacing	§ eB	.310	.370	.430	7.87	9.40	10.92
Mold Draft Angle Top	α	5	10	15	5	10	15
Mold Draft Angle Bottom	β	5	10	15	5	10	15

* Controlling Parameter

§ Significant Characteristic

Notes:

Dimensions D and E1 do not include mold flash or protrusions. Mold flash or protrusions shall not exceed .010" (0.254mm) per side.

JEDEC Equivalent: MS-001

Drawing No. C04-018

8-Lead Plastic Small Outline (SN) – Narrow, 150 mil (SOIC)

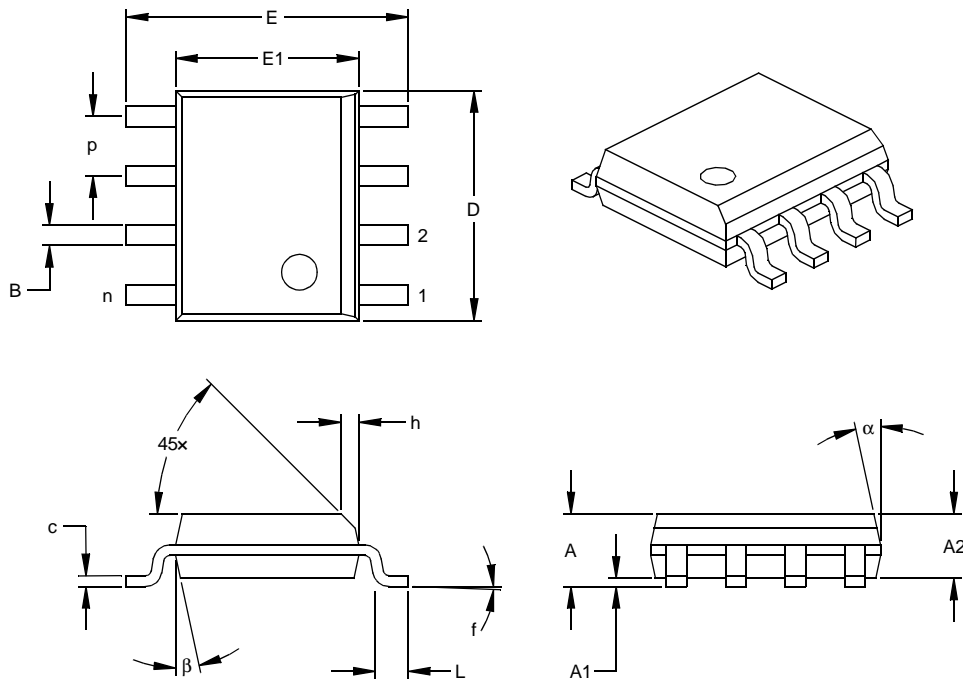

Units		INCHES*			MILLIMETERS		
Dimension	Limits	MIN	NOM	MAX	MIN	NOM	MAX
Number of Pins	n		8			8	
Pitch	p		.050			1.27	
Overall Height	A	.053	.061	.069	1.35	1.55	1.75
Molded Package Thickness	A2	.052	.056	.061	1.32	1.42	1.55
Standoff §	A1	.004	.007	.010	0.10	0.18	0.25
Overall Width	E	.228	.237	.244	5.79	6.02	6.20
Molded Package Width	E1	.146	.154	.157	3.71	3.91	3.99
Overall Length	D	.189	.193	.197	4.80	4.90	5.00
Chamfer Distance	h	.010	.015	.020	0.25	0.38	0.51
Foot Length	L	.019	.025	.030	0.48	0.62	0.76
Foot Angle	f	0	4	8	0	4	8
Lead Thickness	c	.008	.009	.010	0.20	0.23	0.25
Lead Width	B	.013	.017	.020	0.33	0.42	0.51
Mold Draft Angle Top	α	0	12	15	0	12	15
Mold Draft Angle Bottom	β	0	12	15	0	12	15

* Controlling Parameter
 § Significant Characteristic

Notes:

Dimensions D and E1 do not include mold flash or protrusions. Mold flash or protrusions shall not exceed .010" (0.254mm) per side.
 JEDEC Equivalent: MS-012
 Drawing No. C04-057

APPENDIX A: REVISION HISTORY

Revision B

Added note to page 1 header (Not recommended for new designs).

Updated document format.

ON-LINE SUPPORT

Microchip provides on-line support on the Microchip World Wide Web site.

The web site is used by Microchip as a means to make files and information easily available to customers. To view the site, the user must have access to the Internet and a web browser, such as Netscape® or Microsoft® Internet Explorer. Files are also available for FTP download from our FTP site.

Connecting to the Microchip Internet Web Site

The Microchip web site is available at the following URL:

www.microchip.com

The file transfer site is available by using an FTP service to connect to:

<ftp://ftp.microchip.com>

The web site and file transfer site provide a variety of services. Users may download files for the latest Development Tools, Data Sheets, Application Notes, User's Guides, Articles and Sample Programs. A variety of Microchip specific business information is also available, including listings of Microchip sales offices, distributors and factory representatives. Other data available for consideration is:

- Latest Microchip Press Releases
- Technical Support Section with Frequently Asked Questions
- Design Tips
- Device Errata
- Job Postings
- Microchip Consultant Program Member Listing
- Links to other useful web sites related to Microchip Products
- Conferences for products, Development Systems, technical information and more
- Listing of seminars and events

SYSTEMS INFORMATION AND UPGRADE HOT LINE

The Systems Information and Upgrade Line provides system users a listing of the latest versions of all of Microchip's development systems software products. Plus, this line provides information on how customers can receive the most current upgrade kits. The Hot Line Numbers are:

1-800-755-2345 for U.S. and most of Canada, and

1-480-792-7302 for the rest of the world.

042003

93LC46/56/66

READER RESPONSE

It is our intention to provide you with the best documentation possible to ensure successful use of your Microchip product. If you wish to provide your comments on organization, clarity, subject matter, and ways in which our documentation can better serve you, please FAX your comments to the Technical Publications Manager at (480) 792-4150.

Please list the following information, and use this outline to provide us with your comments about this document.

To: Technical Publications Manager
RE: Reader Response
From: Name _____
Company _____
Address _____
City / State / ZIP / Country _____
Telephone: (_____) _____ - _____ FAX: (_____) _____ - _____

Application (optional):

Would you like a reply? ___Y ___N

Device: 93LC46/56/66

Literature Number: DS21712B

Questions:

1. What are the best features of this document?

2. How does this document meet your hardware and software development needs?

3. Do you find the organization of this document easy to follow? If not, why?

4. What additions to the document do you think would enhance the structure and subject?

5. What deletions from the document could be made without affecting the overall usefulness?

6. Is there any incorrect or misleading information (what and where)?

7. How would you improve this document?

PRODUCT IDENTIFICATION SYSTEM

To order or obtain information, e.g., on pricing or delivery, refer to the factory or the listed sales office.

<u>PART NO.</u>	<u>X</u>	<u>/XX</u>	<u>XXX</u>	
Device	Temperature Range	Package	Pattern	
Device	93LC46:	1K 2.5V Microwire Serial EEPROM		
	93LC46X:	1K 2.5V Microwire Serial EEPROM in alternate pinouts (SN package only)		
	93LC46T:	1K 2.5V Microwire Serial EEPROM (Tape and Reel)		
	93LC46XT:	1K 2.5V Microwire Serial EEPROM (Tape and Reel)		
	93LC56:	2K 2.5V Microwire Serial EEPROM		
	93LC56X:	2K 2.5V Microwire Serial EEPROM in alternate pinouts (SN package only)		
	93LC56T:	2K 2.5V Microwire Serial EEPROM (Tape and Reel)		
	93LC56XT:	2K 2.5V Microwire Serial EEPROM (Tape and Reel)		
	93LC66:	4K 2.5V Microwire Serial EEPROM		
	93LC66X:	4K 2.5V Microwire Serial EEPROM in alternate pinouts (SN package only)		
	93LC66T:	4K 2.5V Microwire Serial EEPROM (Tape and Reel)		
	93LC66XT:	4K 2.5V Microwire Serial EEPROM (Tape and Reel)		
Temperature Range	I	= -40°C to +85°C		
Package	P	= Plastic DIP (300 mil body), 8-lead		
	SN	= Plastic SOIC (150 mil body), 8-lead		

Examples:

- a) 93LC46-I/P: 1K, 128x8 or 64x16 Serial EEPROM, PDIP package
- b) 93LC46-I/SN: 1K, 128x8 or 64x16 Serial EEPROM, SOIC package
- c) 93LC46T-I/SN: 1K, 128x8 or 64x16 Serial EEPROM, SOIC package, tape and reel
- d) 93LC46X-I/SN: 1K, 128x8 or 64x16 Serial EEPROM, Rotated SOIC package
- e) 93LC56-I/P: 2K, 256x8 or 128x16 Serial EEPROM, PDIP package
- f) 93LC56-I/SN: 2K, 256x8 or 128x16 Serial EEPROM, SOIC package
- g) 93LC56T-I/SN: 2K, 256x8 or 128x16 Serial EEPROM, SOIC package, tape and reel
- h) 93LC56X-I/SN: 2K, 256x8 or 128x16 Serial EEPROM, Rotated SOIC package
- i) 93LC66-I/P: 4K, 512x8 or 256x16 Serial EEPROM, PDIP package
- j) 93LC66-I/SN: 4K, 512x8 or 256x16 Serial EEPROM, SOIC package
- k) 93LC66T-I/SN: 4K, 512x8 or 256x16 Serial EEPROM, SOIC package, tape and reel
- l) 93LC66X-I/SN: 4K, 512x8 or 256x16 Serial EEPROM, Rotated SOIC package

Sales and Support

Data Sheets

Products supported by a preliminary Data Sheet may have an errata sheet describing minor operational differences and recommended workarounds. To determine if an errata sheet exists for a particular device, please contact one of the following:

1. Your local Microchip sales office
2. The Microchip Corporate Literature Center U.S. FAX: (480) 792-7277
3. The Microchip Worldwide Site (www.microchip.com)

Please specify which device, revision of silicon and Data Sheet (include Literature #) you are using.

New Customer Notification System

Register on our web site (www.microchip.com/cn) to receive the most current information on our products.

93LC46/56/66

NOTES:

Note the following details of the code protection feature on Microchip devices:

- Microchip products meet the specification contained in their particular Microchip Data Sheet.
- Microchip believes that its family of products is one of the most secure families of its kind on the market today, when used in the intended manner and under normal conditions.
- There are dishonest and possibly illegal methods used to breach the code protection feature. All of these methods, to our knowledge, require using the Microchip products in a manner outside the operating specifications contained in Microchip's Data Sheets. Most likely, the person doing so is engaged in theft of intellectual property.
- Microchip is willing to work with the customer who is concerned about the integrity of their code.
- Neither Microchip nor any other semiconductor manufacturer can guarantee the security of their code. Code protection does not mean that we are guaranteeing the product as "unbreakable."

Code protection is constantly evolving. We at Microchip are committed to continuously improving the code protection features of our products. Attempts to break Microchip's code protection feature may be a violation of the Digital Millennium Copyright Act. If such acts allow unauthorized access to your software or other copyrighted work, you may have a right to sue for relief under that Act.

Information contained in this publication regarding device applications and the like is intended through suggestion only and may be superseded by updates. It is your responsibility to ensure that your application meets with your specifications. No representation or warranty is given and no liability is assumed by Microchip Technology Incorporated with respect to the accuracy or use of such information, or infringement of patents or other intellectual property rights arising from such use or otherwise. Use of Microchip's products as critical components in life support systems is not authorized except with express written approval by Microchip. No licenses are conveyed, implicitly or otherwise, under any intellectual property rights.

Trademarks

The Microchip name and logo, the Microchip logo, Accuron, dsPIC, KEELOQ, microID, MPLAB, PIC, PICmicro, PICSTART, PRO MATE, PowerSmart, rfPIC, and SmartShunt are registered trademarks of Microchip Technology Incorporated in the U.S.A. and other countries.

AmpLab, FilterLab, MXDEV, MXLAB, PICMASTER, SEEVAL, SmartSensor and The Embedded Control Solutions Company are registered trademarks of Microchip Technology Incorporated in the U.S.A.

Analog-for-the-Digital Age, Application Maestro, dsPICDEM, dsPICDEM.net, dsPICworks, ECAN, ECONOMONITOR, FanSense, FlexROM, fuzzyLAB, In-Circuit Serial Programming, ICSP, ICEPIC, Migratable Memory, MPASM, MPLIB, MPLINK, MPSIM, PICkit, PICDEM, PICDEM.net, PICLAB, PICtail, PowerCal, PowerInfo, PowerMate, PowerTool, rLAB, rfPICDEM, Select Mode, Smart Serial, SmartTel and Total Endurance are trademarks of Microchip Technology Incorporated in the U.S.A. and other countries.

SQTP is a service mark of Microchip Technology Incorporated in the U.S.A.

All other trademarks mentioned herein are property of their respective companies.

© 2004, Microchip Technology Incorporated, Printed in the U.S.A., All Rights Reserved.

 Printed on recycled paper.

**QUALITY MANAGEMENT SYSTEM
CERTIFIED BY DNV
== ISO/TS 16949:2002 ==**

Microchip received ISO/TS-16949:2002 quality system certification for its worldwide headquarters, design and wafer fabrication facilities in Chandler and Tempe, Arizona and Mountain View, California in October 2003. The Company's quality system processes and procedures are for its PICmicro® 8-bit MCUs, KEELOQ® code hopping devices, Serial EEPROMs, microperipherals, nonvolatile memory and analog products. In addition, Microchip's quality system for the design and manufacture of development systems is ISO 9001:2000 certified.



WORLDWIDE SALES AND SERVICE

AMERICAS

Corporate Office

2355 West Chandler Blvd.
Chandler, AZ 85224-6199
Tel: 480-792-7200
Fax: 480-792-7277
Technical Support: 480-792-7627
Web Address: www.microchip.com

Atlanta

3780 Mansell Road, Suite 130
Alpharetta, GA 30022
Tel: 770-640-0034
Fax: 770-640-0307

Boston

2 Lan Drive, Suite 120
Westford, MA 01886
Tel: 978-692-3848
Fax: 978-692-3821

Chicago

333 Pierce Road, Suite 180
Itasca, IL 60143
Tel: 630-285-0071
Fax: 630-285-0075

Dallas

16200 Addison Road, Suite 255
Addison Plaza
Addison, TX 75001
Tel: 972-818-7423
Fax: 972-818-2924

Detroit

Tri-Atria Office Building
32255 Northwestern Highway, Suite 190
Farmington Hills, MI 48334
Tel: 248-538-2250
Fax: 248-538-2260

Kokomo

2767 S. Albright Road
Kokomo, IN 46902
Tel: 765-864-8360
Fax: 765-864-8387

Los Angeles

25950 Acero St., Suite 200
Mission Viejo, CA 92691
Tel: 949-462-9523
Fax: 949-462-9608

San Jose

1300 Terra Bella Avenue
Mountain View, CA 94043
Tel: 650-215-1444
Fax: 650-961-0286

Toronto

6285 Northam Drive, Suite 108
Mississauga, Ontario L4V 1X5, Canada
Tel: 905-673-0699
Fax: 905-673-6509

ASIA/PACIFIC

Australia

Microchip Technology Australia Pty Ltd
Unit 32 41 Rawson Street
Epping 2121, NSW
Sydney, Australia
Tel: 61-2-9868-6733
Fax: 61-2-9868-6755

China - Beijing

Unit 706B
Wan Tai Bei Hai Bldg.
No. 6 Chaoyangmen Bei Str.
Beijing, 100027, China
Tel: 86-10-85282100
Fax: 86-10-85282104

China - Chengdu

Rm. 2401-2402, 24th Floor,
Ming Xing Financial Tower
No. 88 TIDU Street
Chengdu 610016, China
Tel: 86-28-86766200
Fax: 86-28-86766599

China - Fuzhou

Unit 28F, World Trade Plaza
No. 71 Wusi Road
Fuzhou 350001, China
Tel: 86-591-7503506
Fax: 86-591-7503521

China - Hong Kong SAR

Unit 901-6, Tower 2, Metroplaza
223 Hing Fong Road
Kwai Fong, N.T., Hong Kong
Tel: 852-2401-1200
Fax: 852-2401-3431

China - Shanghai

Room 701, Bldg. B
Far East International Plaza
No. 317 Xian Xia Road
Shanghai, 200051
Tel: 86-21-6275-5700
Fax: 86-21-6275-5060

China - Shenzhen

Rm. 1812, 18/F, Building A, United Plaza
No. 5022 Binhe Road, Futian District
Shenzhen 518033, China
Tel: 86-755-82901380
Fax: 86-755-82951393

China - Shunde

Room 401, Hongjian Building, No. 2
Fengxiangnan Road, Ronggui Town, Shunde
District, Foshan City, Guangdong 528303, China
Tel: 86-757-28395507 Fax: 86-757-28395571

China - Qingdao

Rm. B505A, Fullhope Plaza,
No. 12 Hong Kong Central Rd.
Qingdao 266071, China
Tel: 86-532-5027355 Fax: 86-532-5027205

India

Divyasree Chambers
1 Floor, Wing A (A3/A4)
No. 11, O'Shaughnessey Road
Bangalore, 560 025, India
Tel: 91-80-22290061 Fax: 91-80-22290062

Japan

Yusen Shin Yokohama Building 10F
3-17-2, Shin Yokohama, Kohoku-ku,
Yokohama, Kanagawa, 222-0033, Japan
Tel: 81-45-471-6166 Fax: 81-45-471-6122

Korea

168-1, Youngbo Bldg. 3 Floor
Samsung-Dong, Kangnam-Ku
Seoul, Korea 135-882
Tel: 82-2-554-7200 Fax: 82-2-558-5932 or
82-2-558-5934

Singapore

200 Middle Road
#07-02 Prime Centre
Singapore, 188980
Tel: 65-6334-8870 Fax: 65-6334-8850

Taiwan

Kaohsiung Branch
30F - 1 No. 8
Min Chuan 2nd Road
Kaohsiung 806, Taiwan
Tel: 886-7-536-4816
Fax: 886-7-536-4817

Taiwan

Taiwan Branch
11F-3, No. 207
Tung Hua North Road
Taipei, 105, Taiwan
Tel: 886-2-2717-7175 Fax: 886-2-2545-0139

Taiwan

Taiwan Branch
13F-3, No. 295, Sec. 2, Kung Fu Road
Hsinchu City 300, Taiwan
Tel: 886-3-572-9526
Fax: 886-3-572-6459

EUROPE

Austria

Durisolstrasse 2
A-4600 Wels
Austria
Tel: 43-7242-2244-399
Fax: 43-7242-2244-393

Denmark

Regus Business Centre
Lautrup hoj 1-3
Ballerup DK-2750 Denmark
Tel: 45-4420-9895 Fax: 45-4420-9910

France

Parc d'Activite du Moulin de Massy
43 Rue du Saule Trapu
Batiment A - ler Etage
91300 Massy, France
Tel: 33-1-69-53-63-20
Fax: 33-1-69-30-90-79

Germany

Steinheilstrasse 10
D-85737 Ismaning, Germany
Tel: 49-89-627-144-0
Fax: 49-89-627-144-44

Italy

Via Salvatore Quasimodo, 12
20025 Legnano (MI)
Milan, Italy
Tel: 39-0331-742611
Fax: 39-0331-466781

Netherlands

Waegenburghtplein 4
NL-5152 JR, Drunen, Netherlands
Tel: 31-416-690399
Fax: 31-416-690340

United Kingdom

505 Eskdale Road
Winnersh Triangle
Wokingham
Berkshire, England RG41 5TU
Tel: 44-118-921-5869
Fax: 44-118-921-5820

07/12/04



LittleDiode supplies new, hard to find or obsolete electronic components and semiconductors all over the world.

With over two million different components listed you are sure to find the part you need.

Feel free to visit us today at our online store:

LittleDiode.com

Looking forward to providing you with the best possible service.