

THREE TERMINAL ADJUSTABLE CURRENT SOURCES

- OPERATES from 1V to 40V
- 0.02% V CURRENT REGULATION
- PROGRAMMABLE from 1 μ A to 10mA
- \pm 3% INITIAL ACCURACY

DESCRIPTION

The LM134/LM234/LM334 are 3-terminal adjustable current sources characterized by :

- an operating current range of 10000 : 1
- an excellent current regulation
- a wide dynamic voltage range of 1V to 40V

The current is determined by an external resistor without requiring other external components.

Reverse voltages of up to 20V will only draw a current of several microamperes. This enables the circuit to operate as a rectifier and as a source of current in a.c. applications.

For the LM134/LM234/LM334, the voltage on the control pin is 64mV at +25°C and is directly proportional to the absolute temperature ($^{\circ}$ K). The simplest external resistor connection generates a current with \approx 0.33%/ $^{\circ}$ C temperature dependence. Zero drift can be obtained by adding an additional resistor and a diode to the external circuit.

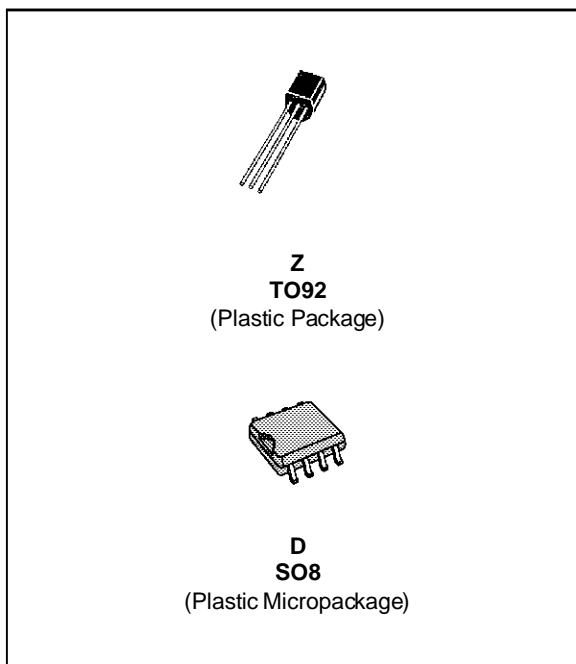

ORDER CODES

| Part Number | Temperature Range | Package | |
|-------------|-------------------|---------|---|
| | | Z | D |
| LM134 | -55°C, +125°C | • | • |
| LM234 | -25°C, +100°C | • | • |
| LM334 | 0°C, +70°C | • | • |

Example : LM134Z

134-01.TBL

PIN CONNECTIONS

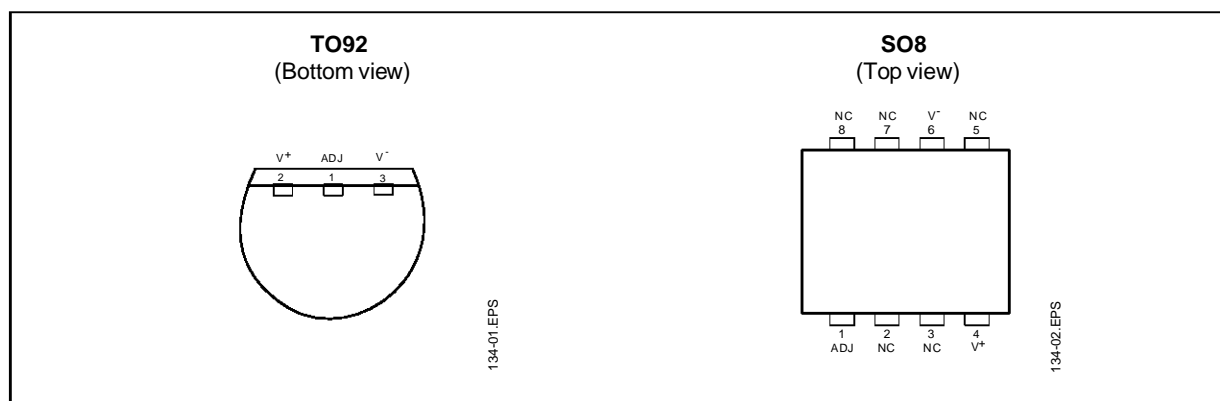

SCHEMATIC DIAGRAM

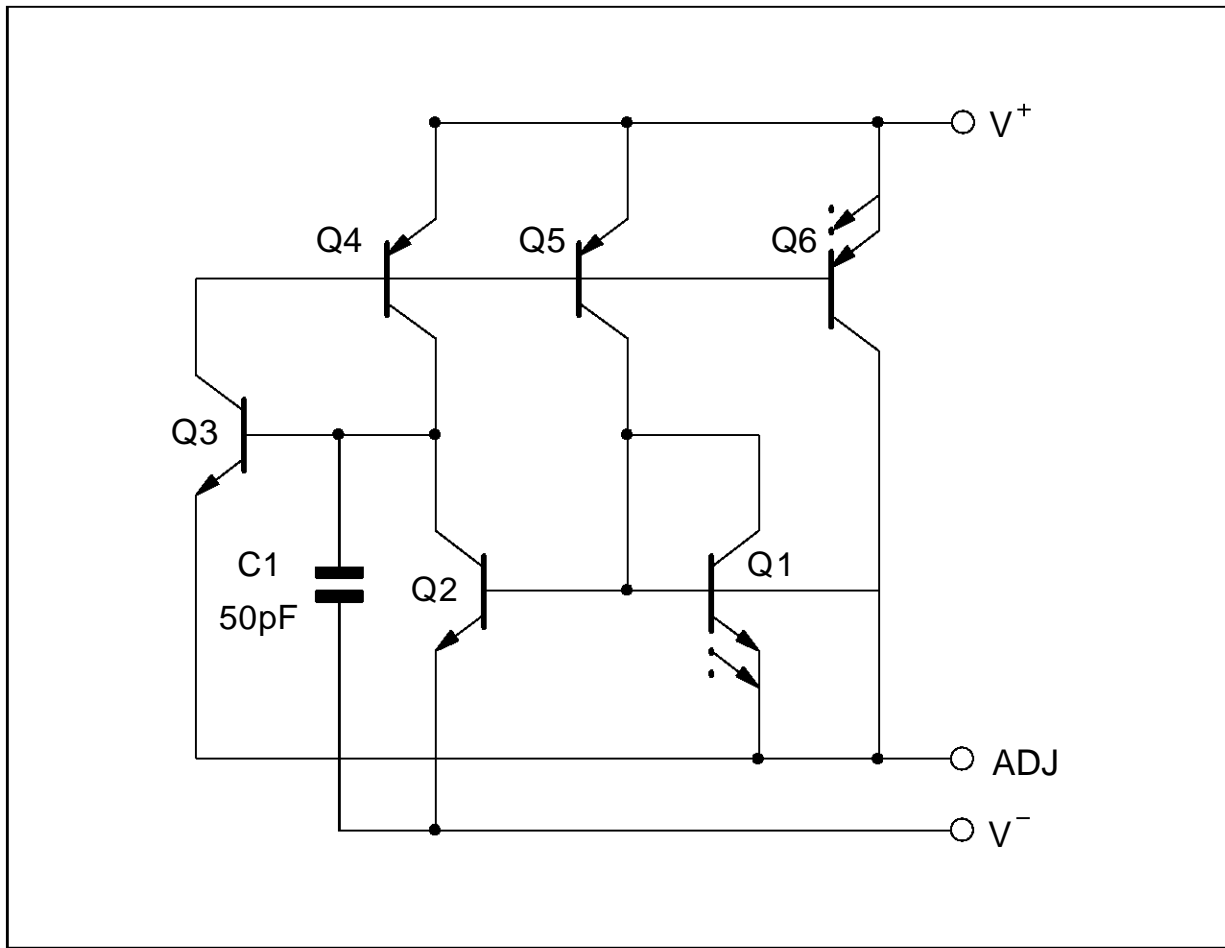

134-03.EPS

ABSOLUTE MAXIMUM RATING

| Symbol | Parameter | LM134 - LM234 | LM334 | Unit |
|------------|--|-------------------------|--|------|
| | Voltage V^+ to V^- Forward Reverse | 40 20 | 30 20 | V |
| V_{ADJ} | ADJ Pin to V^- Voltage | 5 | 5 | V |
| I_{SET} | Set Current | 10 | 10 | mA |
| P_{tot} | Power Dissipation | 400 | 400 | mW |
| T_{stg} | Storage Temperature Range | -65 to +150 | | °C |
| T_{oper} | Operating Free-air Temperature Range | LM134 LM234 LM334 | -55 to +125 -25 to +100 0 to +70 | °C |

134-02.TBL

ELECTRICAL CHARACTERISTICS

$T_j = +25^\circ\text{C}$ with pulse testing so that junction temperature does not change during testing (unless otherwise specified)

| Parameter | LM134 - LM234 | | | LM334 | | | Unit |
|--|---------------|-----------------|--------------|--------|-----------------|--------------|-------|
| | Min. | Typ. | Max. | Min. | Typ. | Max. | |
| Set Current Error ($V^+ = +2.5\text{V}$) - (note 1) $10\mu\text{A} \leq I_{\text{SET}} \leq 1\text{mA}$ $1\text{mA} \leq I_{\text{SET}} \leq 5\text{mA}$ $2\mu\text{A} \leq I_{\text{SET}} \leq 10\mu\text{A}$ | | | 3 5 8 | | | 6 8 12 | % |
| Ratio of Set Current to V^- Current $10\mu\text{A} \leq I_{\text{SET}} \leq 1\text{mA}$ $1\text{mA} \leq I_{\text{SET}} \leq 5\text{mA}$ $2\mu\text{A} \leq I_{\text{SET}} \leq 10\mu\text{A}$ | 14 | 18 14 14 | 23 | 14 | 18 14 14 | 26 | |
| Minimum Operating Voltage $2\mu\text{A} \leq I_{\text{SET}} \leq 100\mu\text{A}$ $100\mu\text{A} \leq I_{\text{SET}} \leq 1\text{mA}$ $1\text{mA} \leq I_{\text{SET}} \leq 5\text{mA}$ | | 0.8 0.9 1 | | | 0.8 0.9 1 | | V |
| Average change in set current with input voltage $2\mu\text{A} \leq I_{\text{SET}} \leq 1\text{mA}$ $+1.5\text{V} \leq V^+ \leq +5\text{V}$ $+5\text{V} \leq V^+ \leq +40\text{V}$ $1\text{mA} \leq I_{\text{SET}} \leq 5\text{mA}$ $+1.5\text{V} \leq V^+ \leq +5\text{V}$ $+5\text{V} \leq V^+ \leq +40\text{V}$ | | 0.02 0.01 | 0.05 0.03 | | 0.02 0.01 | 0.1 0.05 | % / V |
| Temperature Dependence of set current - (note 2) $25\mu\text{A} \leq I_{\text{SET}} \leq 1\text{mA}$ | 0.96 T | T | 1.04 T | 0.96 T | T | 1.04 T | |
| Effective Shunt Capacitance | | 15 | | | 15 | | pF |

134-03.TBL

- Notes :**
- Set current is the current flowing into the V^+ pin. It is determined by the following formula $I_{\text{set}} = 67.7\text{mV}/R_{\text{set}}$ ($T_j = +25^\circ\text{C}$). Set current error is expressed as a percent deviation from this amount.
 - I_{set} is directly proportional to absolute temperature ($^\circ\text{K}$). I_{set} at any temperature can be calculated from $I_{\text{set}} = I_0 (T/T_0)$ where I_0 is I_{set} measured at T_0 ($^\circ\text{K}$).

OUTPUT IMPEDANCE

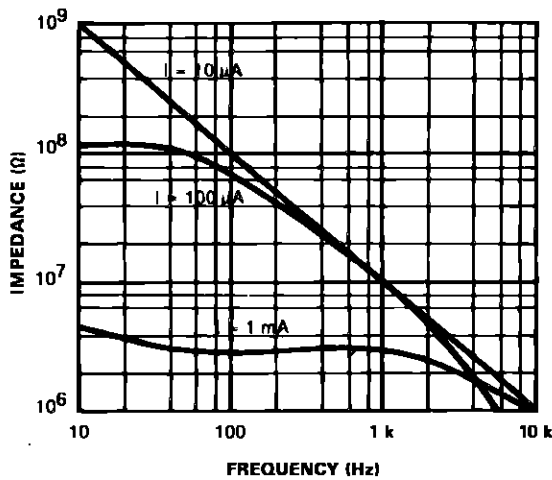

134-04.EPS

MAXIMUM SLEW RATE FOR LINEAR OPERATION

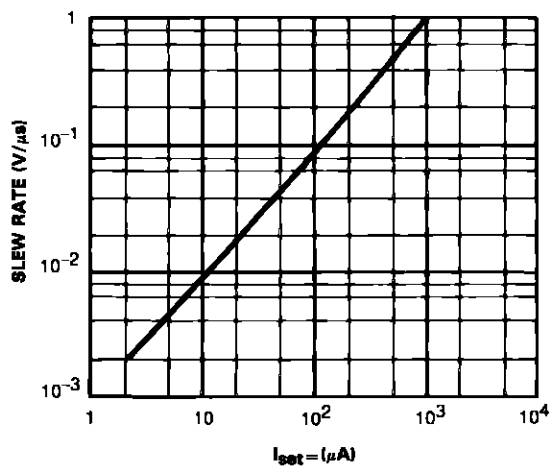

134-05.EPS

START UP

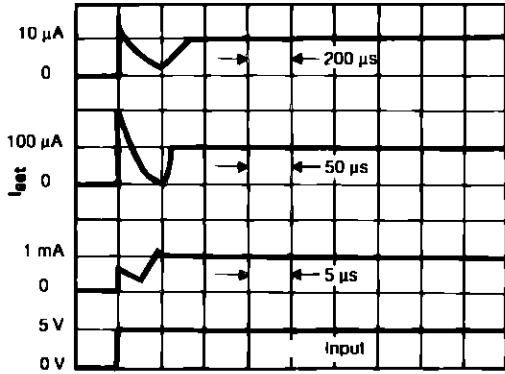

TIME (SCALE CHANGES AT EACH CURRENT LEVEL).

134-06.EPS

TRANSIENT RESPONSE

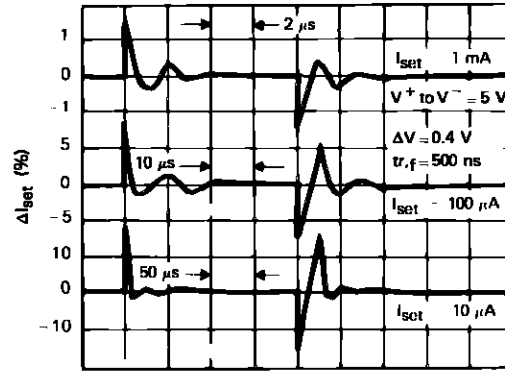

TIME (SCALE CHANGES AT EACH CURRENT LEVEL).

134-07.EPS

VOLTAGE ACROSS R_{set}

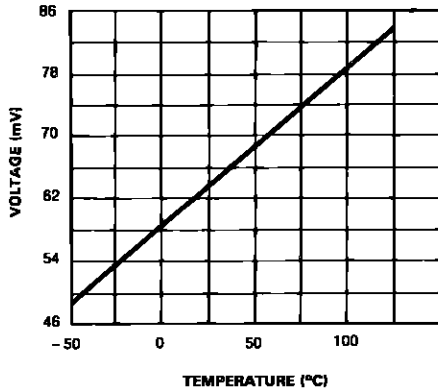

134-08.EPS

CURRENT NOISE

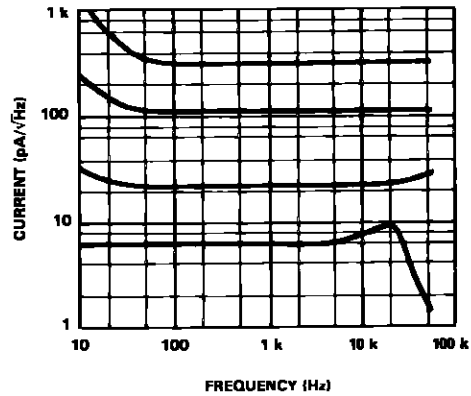

134-09.EPS

TURN-ON VOLTAGE

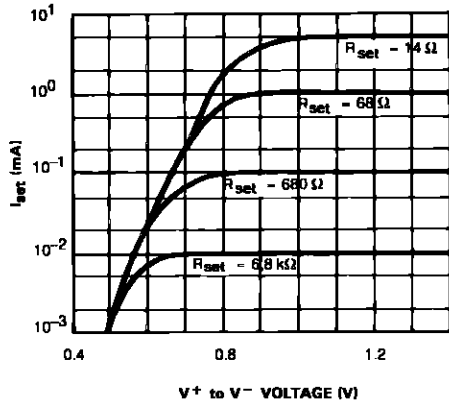

134-10.EPS

RATIO OF I_{set} to V^- CURRENT

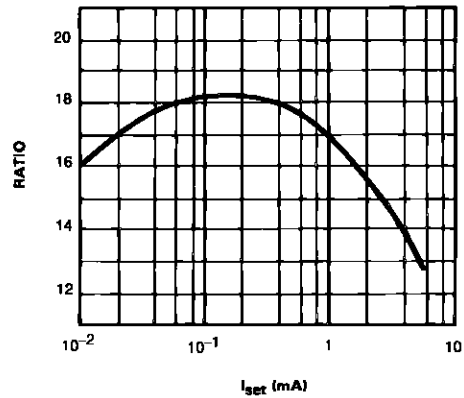

135-11.EPS

APPLICATION HINT

SLEW RATE

At slew rates above a threshold (see curve) the LM134, LM234, LM334 can have a non-linear current characteristic. The slew rate at which this takes place is directly proportional to I_{set} . At $I_{set} = 10\mu A$, $dv/dt \text{ max.} = 0.01V/\mu S$; at $I_{set} = 1mA$, $dv/dt \text{ max.} = 1V/\mu S$. Slew rates of more than $1V/\mu S$ do not damage the circuit nor do they produce high currents.

THERMAL EFFECTS

Internal heating can have a significant effect on current regulation for an I_{set} above $100\mu A$. For example, each increase of 1V in the voltage across the LM134 at $I_{set} = 1mA$ will increase the junction temperature by $\approx 0.4^\circ C$ (in still air). The output current (I_{set}) has a temperature coefficient of about $0.33\%/^\circ C$. Thus the change in current due to the increase in temperature will be $(0.4)(0.33) = 0.132\%$. This is a degradation of 10 : 1 in regulation versus the true electrical effects. Thermal effects should be taken into account when d.c. regulation is critical and I_{set} is higher than $100\mu A$. The dissipation of the connections of CB-97 package can reduce this thermal effect by a coefficient of more than 3.

SHUNT CAPACITANCE

In certain applications, the 15pF value for the shunt capacitance should be reduced :

- because of loading problems,
- because of limitation of the output impedance of the current source in a.c. applications. This reduction of the capacitance can be easily carried out by adding a FET as indicated in the typical applications. The value of this capacitance can be reduced by at least 3pF and regulation can be improved by an order of magnitude without any modification of the d.c. characteristics (except for the minimum input voltage).

NOISE

The current noise produced by LM134, LM234, LM334 is about 4 times that of a transistor. If the LM134, LM234, LM334 is utilized as an active load for a transistor amplifier, the noise at the input will increase by about 12dB. In most cases this is acceptable, and a single amplifier can be built with a voltage gain higher than 2000.

LEAD RESISTANCE

The sense voltage which determines the current of the LM134, LM234, LM334, is less than 100mV. At this level, the effects of the thermocouple and the

connection resistance should be reduced by locating the current setting resistor close to the device. Do not use sockets for the ICs. A contact resistance of 0.7Ω is sufficient to decrease the output current by 1% at the 1mA level.

SENSING TEMPERATURE

The LM134, LM234, LM334 are excellent remote controlled temperature sensors because their operation as sources of current preserves their accuracy even in the case of long connecting wires. The output current is directly proportional to the absolute temperature in degrees Kelvin according to the following equation.

$$I_{set} = \frac{(227\mu V/^\circ K) (T)}{R_{set}}$$

The calibration of the LM134, LM234, LM334 is simplified by the fact that most of the initial accuracy is due to gain limitation (slope error) and not an offset. Gain adjustment is a one point trim because the output of the device extrapolates to zero at $0^\circ K$.

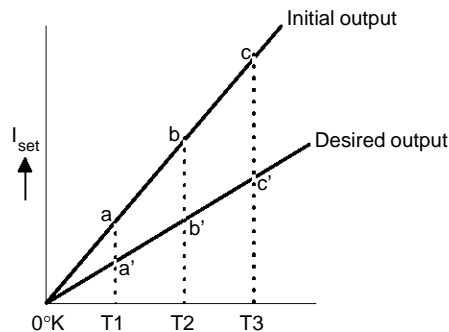

134-12.EPS

This particularity of the LM134, LM234, LM334 is illustrated in the above diagram. Line abc represents the sensor current before adjustment and line a'b'c' represents the desired output. An adjustment of the gain provided at T2 will move the output from b to b' and will correct the slope at the same time so that the output at T1 and T3 will be correct. This gain adjustment can be carried out by means of R_{set} or the load resistor utilized in the circuit. After adjustment, the slope error should be less than 1%. A low temperature coefficient for R_{set} is necessary to keep this accuracy. A $33ppm/^\circ C$ temperature drift of R_{set} will give an error of 1% on the slope because the resistance follows the same temperature variations as the LM134, LM234, LM334. Three wires are required to isolate R_{set} from the LM134, LM234, LM334. Since this solution is not recommended. Metal-film resistors with a drift less than $20ppm/^\circ C$ are now available. Wirewound resistors can be utilized when very high stability is required.

TYPICAL APPLICATIONS

Figure 1 : Basic 2-terminal Current Source

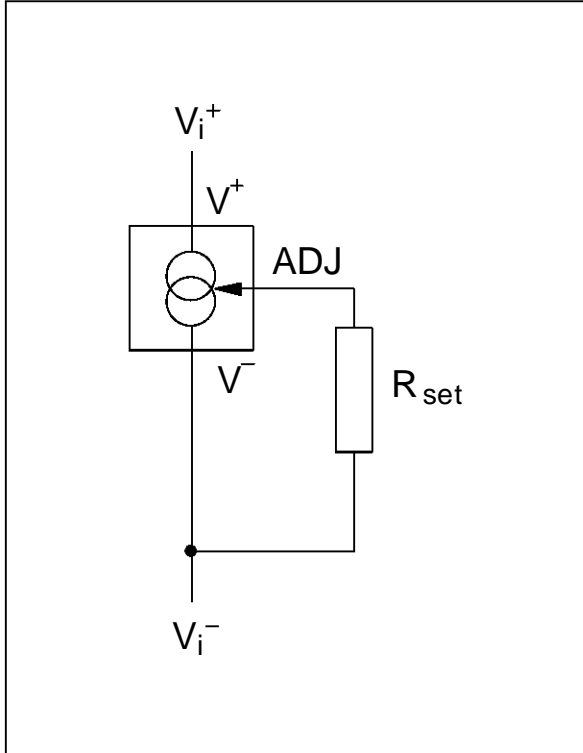

134-13.EPS

Figure 2 : Alternate Trimming Technique

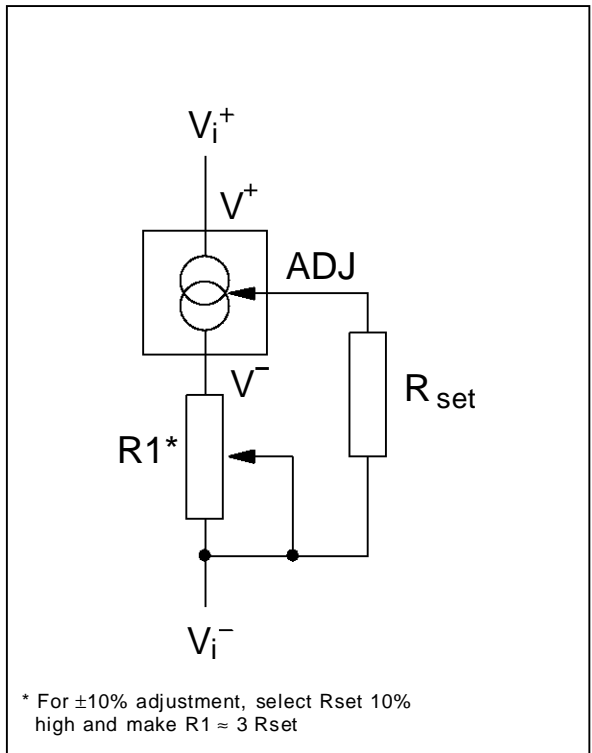

* For $\pm 10\%$ adjustment, select R_{set} 10% high and make $R1 \approx 3 R_{set}$

134-14.EPS

Figure 3 : Terminating Remote Sensor for Voltage Output

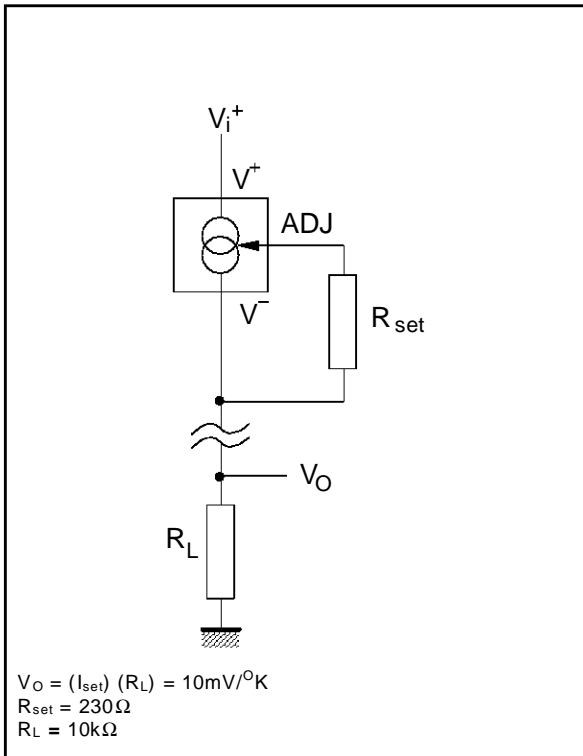

$V_O = (I_{set})(R_L) = 10mV/^\circ K$
 $R_{set} = 230\Omega$
 $R_L = 10k\Omega$

134-15.EPS

Figure 4 : Zero Temperature Coefficient Current Source

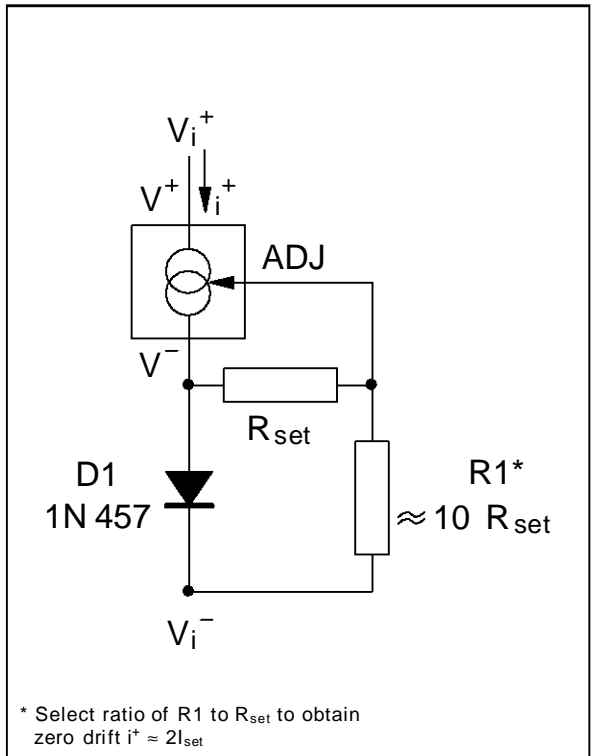

* Select ratio of $R1$ to R_{set} to obtain zero drift $i^+ \approx 2I_{set}$

134-16.EPS

Figure 5 : Low Output Impedance Thermometer

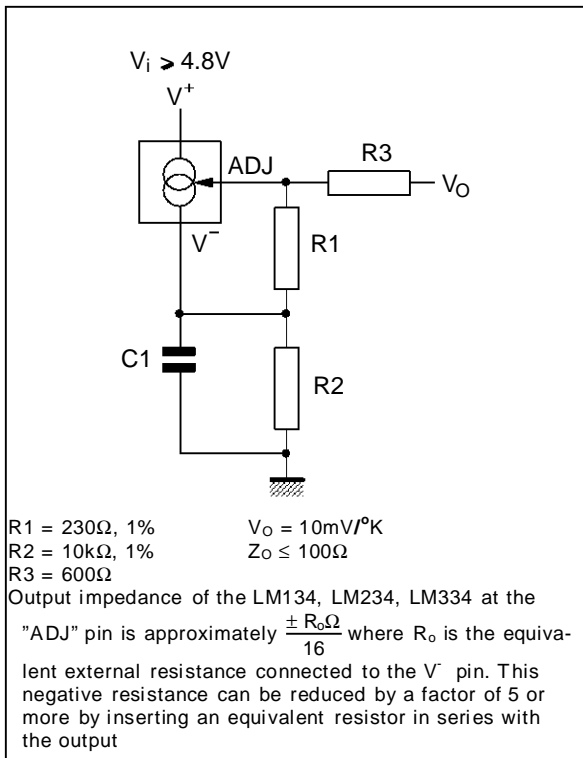

Figure 6 : Low Output Impedance Thermometer

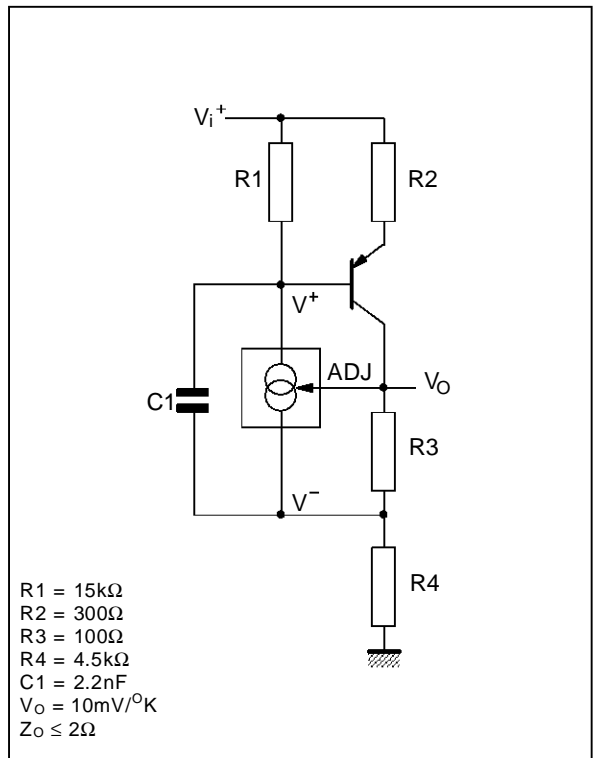

Figure 7 : Micropower Bias

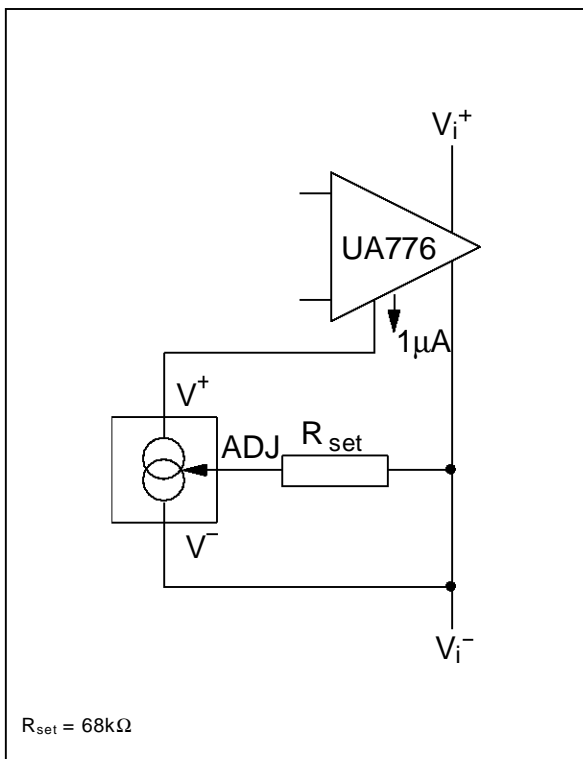

Figure 8 : Low Input Voltage Reference Driver

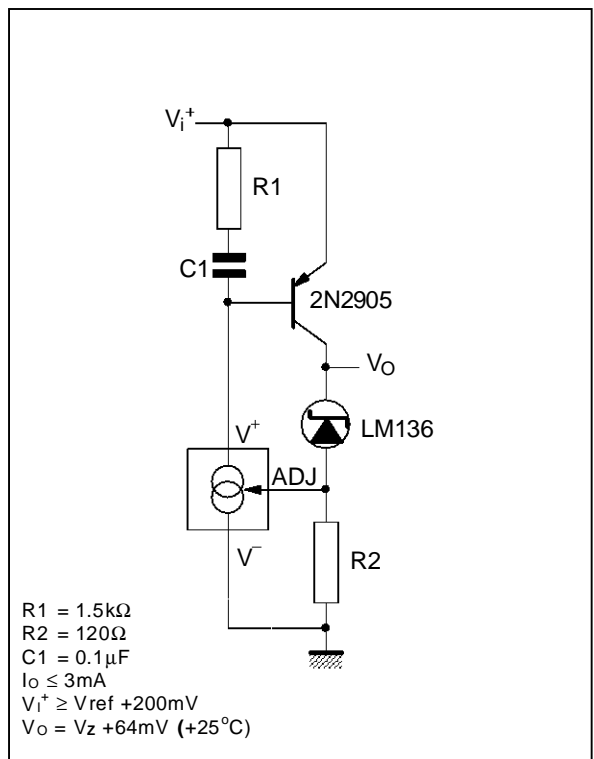

Figure 9 : In-line Current Limiter

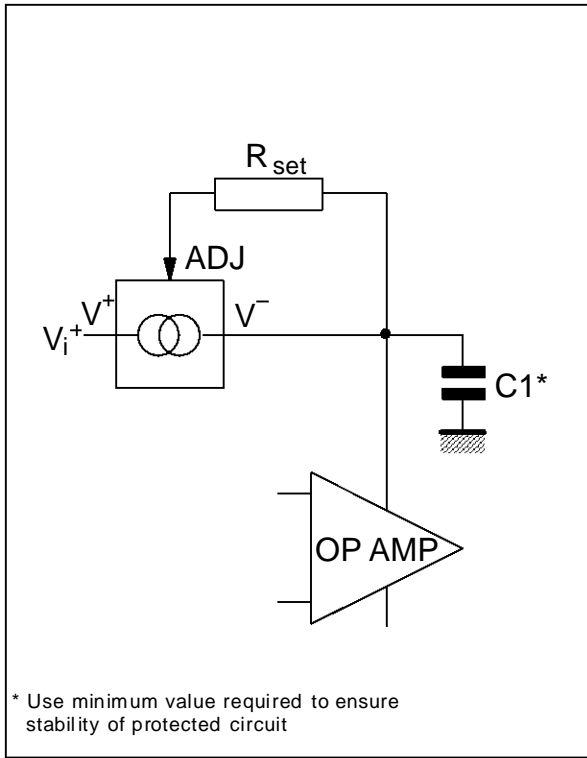
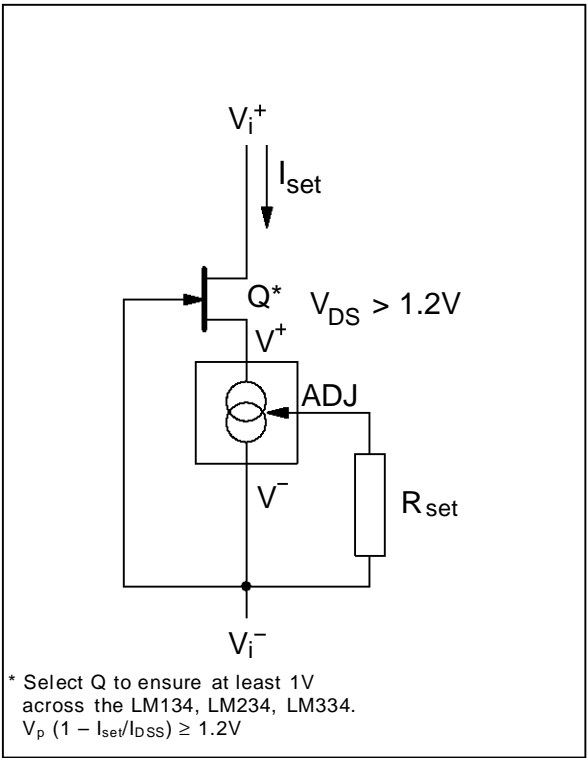
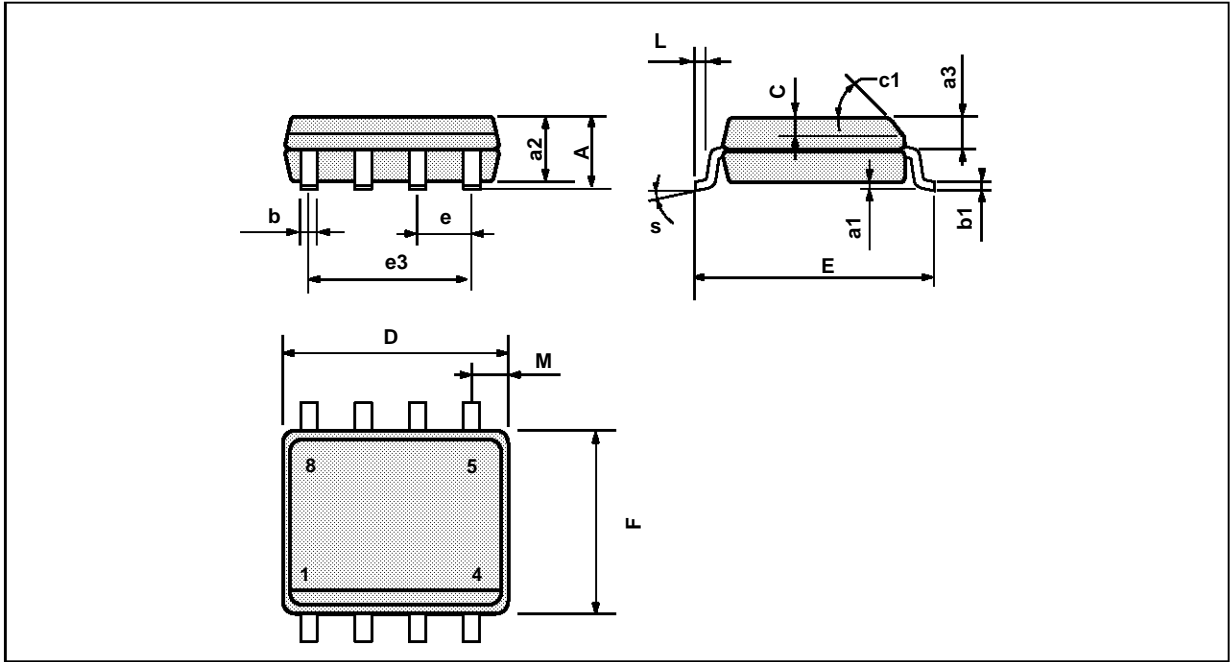

Figure 10 : Fet Cascading for Low Capacitance



PACKAGE MECHANICAL DATA
8 PINS - PLASTIC MICROPACKAGE (SO)



PM-SO8.EPS

| Dimensions | Millimeters | | | Inches | | |
|------------|-------------|------|------|--------|-------|-------|
| | Min. | Typ. | Max. | Min. | Typ. | Max. |
| A | | | 1.75 | | | 0.069 |
| a1 | 0.1 | | 0.25 | 0.004 | | 0.010 |
| a2 | | | 1.65 | | | 0.065 |
| a3 | 0.65 | | 0.85 | 0.026 | | 0.033 |
| b | 0.35 | | 0.48 | 0.014 | | 0.019 |
| b1 | 0.19 | | 0.25 | 0.007 | | 0.010 |
| C | 0.25 | | 0.5 | 0.010 | | 0.020 |
| c1 | 45° (typ.) | | | | | |
| D | 4.8 | | 5.0 | 0.189 | | 0.197 |
| E | 5.8 | | 6.2 | 0.228 | | 0.244 |
| e | | 1.27 | | | 0.050 | |
| e3 | | 3.81 | | | 0.150 | |
| F | 3.8 | | 4.0 | 0.150 | | 0.157 |
| L | 0.4 | | 1.27 | 0.016 | | 0.050 |
| M | | | 0.6 | | | 0.024 |
| S | 8° (max.) | | | | | |

SO8.TBL

LM134-LM234-LM334

PACKAGE MECHANICAL DATA 3 PINS - PLASTIC PACKAGE TO92

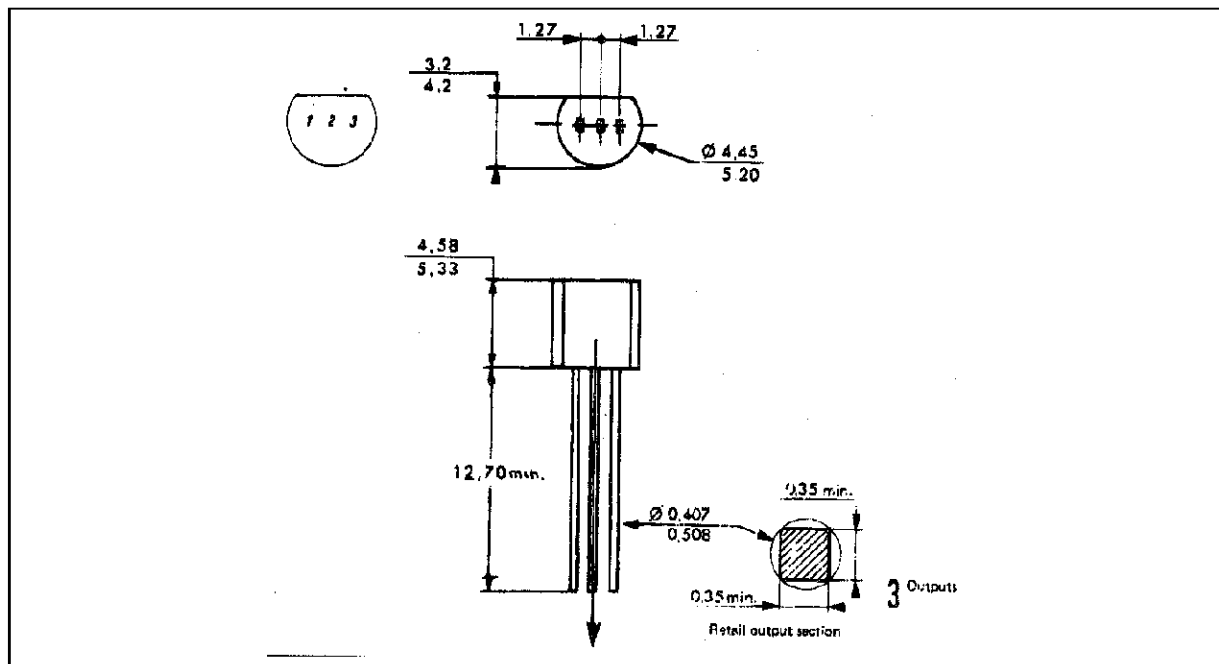

| Dimensions | Millimeters | | | Inches | | |
|------------|-------------|------|-------|--------|--------|--------|
| | Min. | Typ. | Max. | Min. | Typ. | Max. |
| L | | 1.27 | | | 0.05 | |
| B | 3.2 | 3.7 | 4.2 | 0.126 | 0.1457 | 0.1654 |
| O1 | 4.45 | 5.00 | 5.2 | 0.1752 | 0.1969 | 0.2047 |
| C | 4.58 | 5.03 | 5.33 | 0.1803 | 0.198 | 0.2098 |
| K | 12.7 | | | 0.5 | | |
| O2 | 0.407 | 0.5 | 0.508 | 0.016 | 0.0197 | 0.02 |
| a | 0.35 | | | 0.0138 | | |

Information furnished is believed to be accurate and reliable. However, SGS-THOMSON Microelectronics assumes no responsibility for the consequences of use of such information nor for any infringement of patents or other rights of third parties which may result from its use. No licence is granted by implication or otherwise under any patent or patent rights of SGS-THOMSON Microelectronics. Specifications mentioned in this publication are subject to change without notice. This publication supersedes and replaces all information previously supplied. SGS-THOMSON Microelectronics products are not authorized for use as critical components in life support devices or systems without express written approval of SGS-THOMSON Microelectronics.

© 1994 SGS-THOMSON Microelectronics - All Rights Reserved

SGS-THOMSON Microelectronics GROUP OF COMPANIES

Australia - Brazil - France - Germany - Hong Kong - Italy - Japan - Korea - Malaysia - Malta - Morocco - The Netherlands
Singapore - Spain - Sweden - Switzerland - Taiwan - Thailand - United Kingdom - U.S.A.