

MOTOR SPEED REGULATOR

- EXCELLENT VERSATILITY IN USE
- HIGH OUTPUT CURRENT (UP TO 800mA)
- LOW QUIESCENT CURRENT (1.7mA)
- LOW REFERENCE VOLTAGE (1.2V)
- EXCELLENT PARAMETERS STABILITY VERSUS TEMPERATURE

DESCRIPTION

The TDA1151 is a monolithic integrated circuit in SOT-32 plastic package. It is intended for use as speed regulator for DC motors of record players, tape and cassette recorders, movie cameras, toys etc.

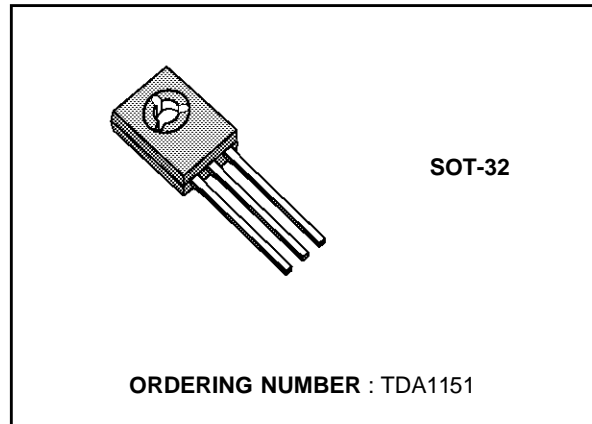

ABSOLUTE MAXIMUM RATINGS

Symbol	Parameter	Value	Unit
V_s	Supply voltage	20	V
P_{tot}	Total power dissipation at $T_{amb} = 70^{\circ}C$	0.8	W
	at $T_{case} = 100^{\circ}C$	5	W
T_{stg}, T_j	Storage and junction temperature	-40 to 150	$^{\circ}C$

APPLICATION CIRCUIT

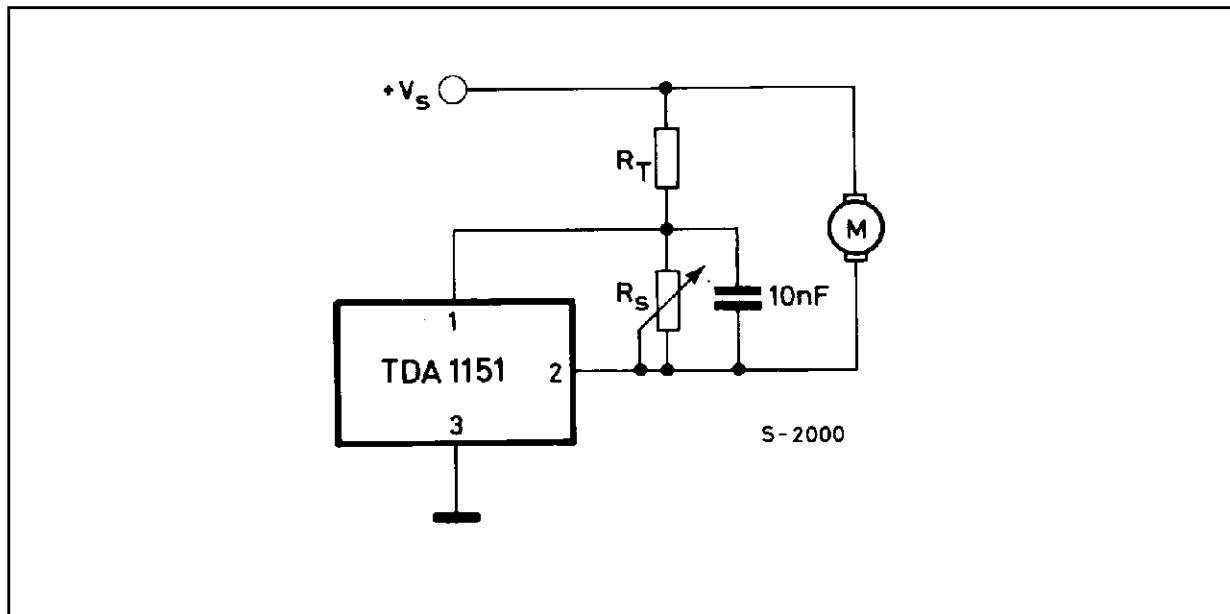

TDA1151

CONNECTION DIAGRAM

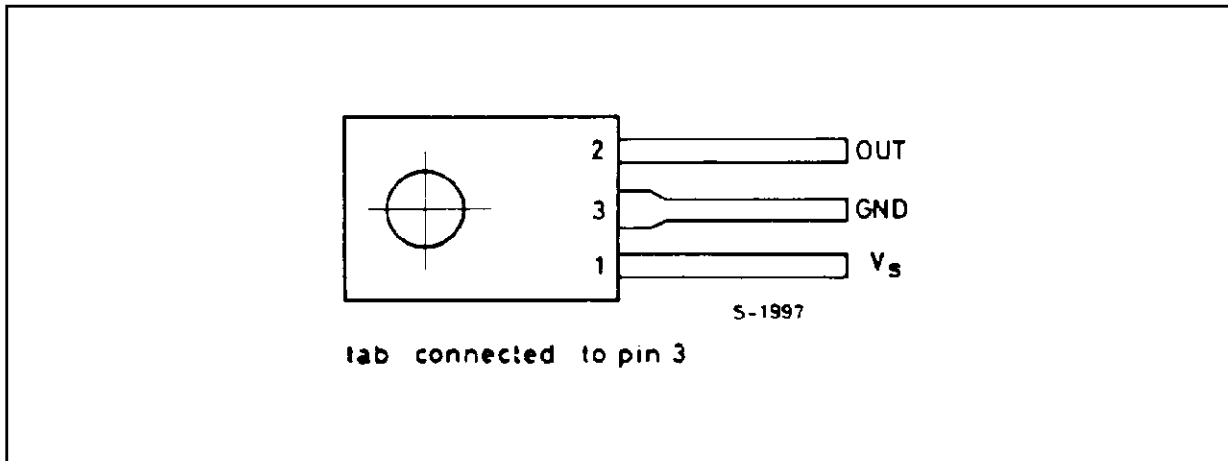

TEST CIRCUIT

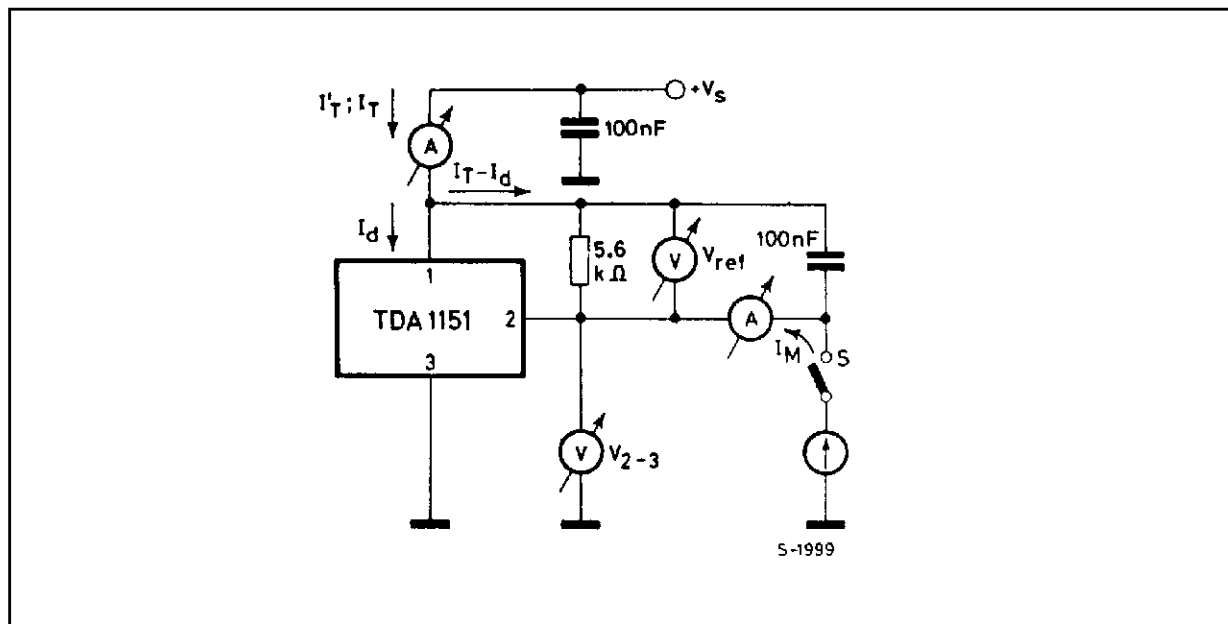

THERMAL DATA

Symbol	Parameter	Value	Unit
$R_{th\ j-case}$	Thermal resistance junction-case	max 10	°C/W
$R_{th\ j-amb}$	Thermal resistance junction-ambient	max 100	°C/W

ELECTRICAL CHARACTERISTICS (Refer to the test circuit, $T_{amb} = 25\text{ °C}$)

Symbol	Parameter	Test conditions	Min.	Typ.	Max.	Unit
V_{ref}	Reference voltage (between pins 1 and 2)	$V_s = 6V$ $I_M = 0.1A$	1.1	1.2	1.3	V
I_d	Quiescent drain current	$V_s = 6V$ $I_M = 100\ \mu A$		1.7		mA
I_{MS}	Starting current	$V_s = 5V$ $\Delta V_{ref}/V_{ref} = -50\%$	0.8			A
V_{1-3}	Minimum supply voltage	$I_m = 0.1A$ $\Delta V_{ref}/V_{ref} = -5\%$			2.5	V
$K=I_m/I_T$	Reflection coefficient	$V_s = 6V$ $I_M = 0.1A$	18	20	22	
$\frac{\Delta K}{K} / \Delta V_s$		$V_s = 6V$ to $18V$ $I_m = 0.1A$		0.45		%/V
$\frac{\Delta K}{K} / \Delta I_M$		$V_s = 6V$ $I_m = 25$ to $400\ mA$		0.005		%/mA
$\frac{\Delta K}{K} / \Delta T$		$V_s = 6V$ $I_m = 0.1A$ $T_{amb} = -20$ to 70 °C		0.02		%/°C
$\frac{\Delta V_{ref}}{V_{ref}} / \Delta V_s$	Line regulation	$V_s = 6V$ to $18V$ $I_M = 0.1A$		0.02		%/V
$\frac{\Delta V_{ref}}{V_{ref}} / \Delta I_M$	Load regulation	$V_s = 6V$ $I_m = 25$ to $400\ mA$		0.009		%/mA
$\frac{\Delta V_{ref}}{V_{ref}} / \Delta T$	Temperature coefficient	$V_s = 6V$ $I_m = 0.1A$ $T_{amb} = -20$ to 70 °C		0.02		%/°C

Figure 1. Quiescent drain current vs. power supply

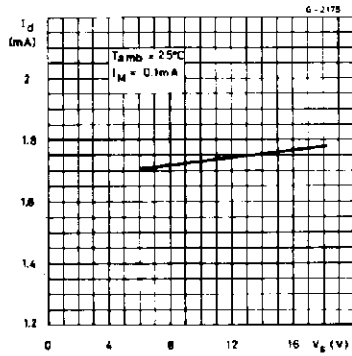

Figure 2. Quiescent drain current vs. ambient temperature

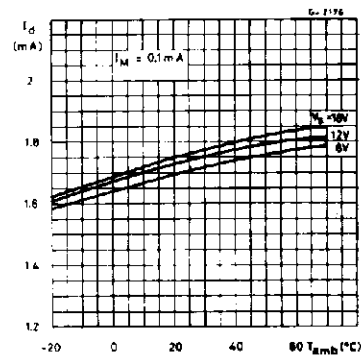

Figure 3. Reference voltage vs. supply voltage

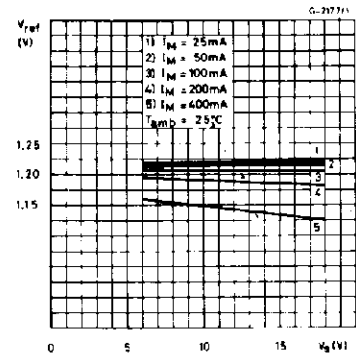

Figure 4. Reference voltage vs. motor current

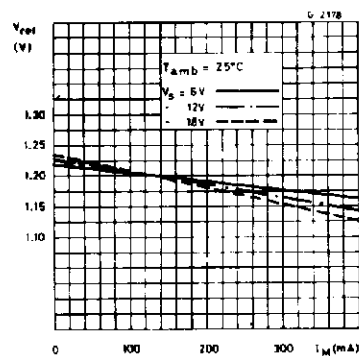

Figure 5. Reference voltage vs. ambient temperature

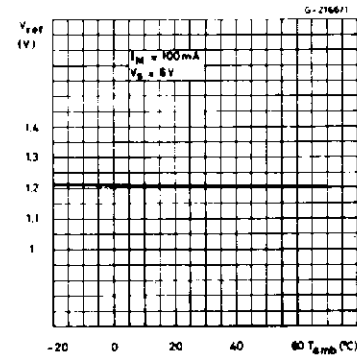

Figure 6. Reflection coefficient vs. supply voltage

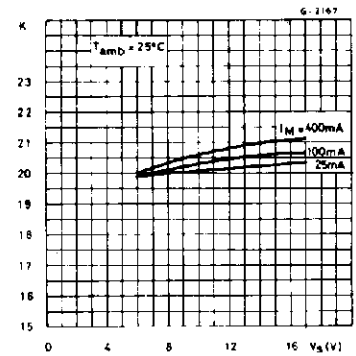

Figure 7. Reflection coefficient vs. motor current

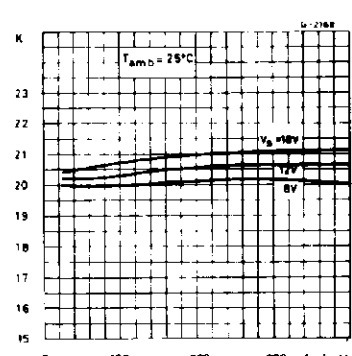

Figure 8. Reflection coefficient vs. ambient temperature

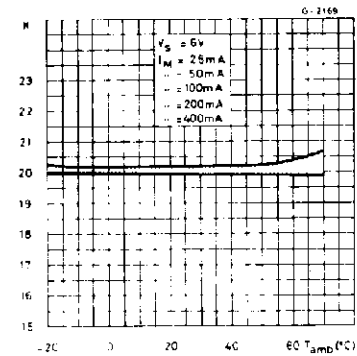

Figure 9. Typical minimum supply voltage vs. motor current

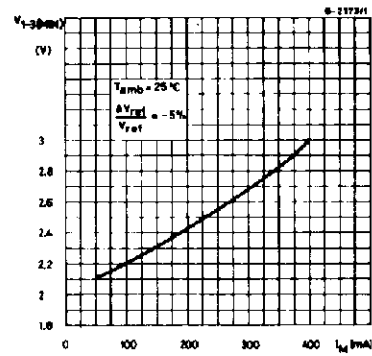
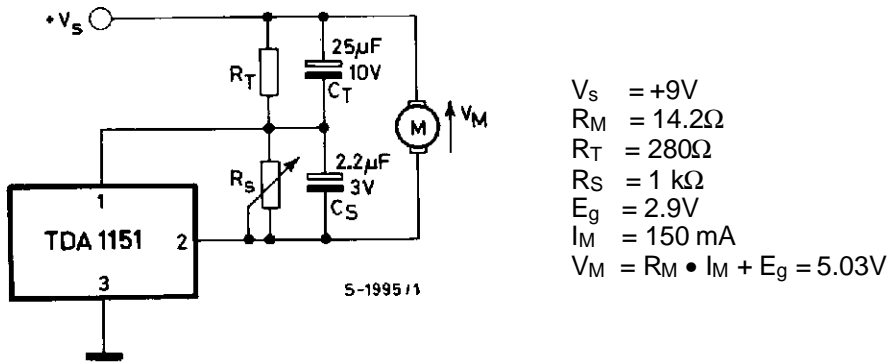

Figure 10. Application circuit



Note: A ceramic capacitor of 10 nF between pins, 1 and 2 improves stability in some applications.

Figure 11. P.C. board and component layout of the circuit of Fig. 10 (1 : 1 scale)

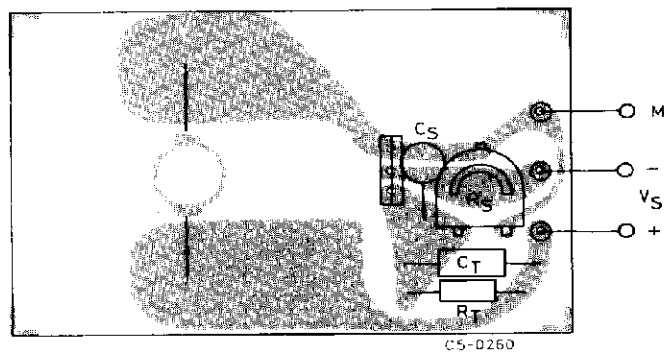

Figure 12. Speed variation vs. supply voltage

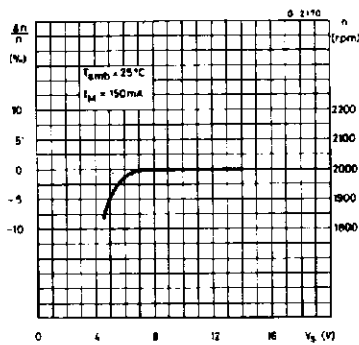

Figure 13. Speed variation vs. motor current

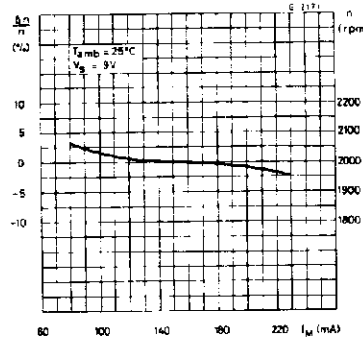

Figure 14. Speed variation vs. ambient temperature

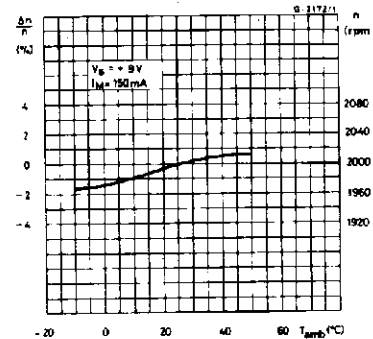

Figure 15. Low cost application circuit

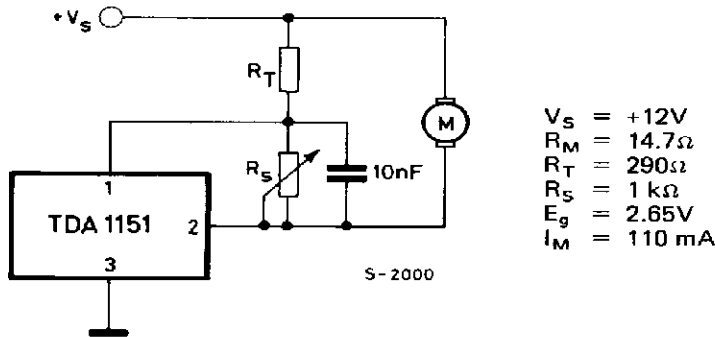

Figure 16. Speed variation vs. supply voltage

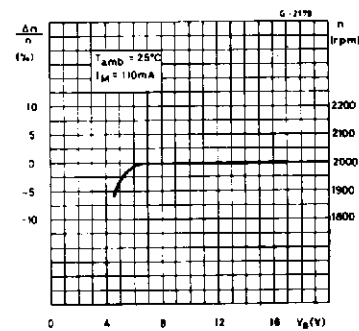

Figure 17. Speed variation vs. motor current

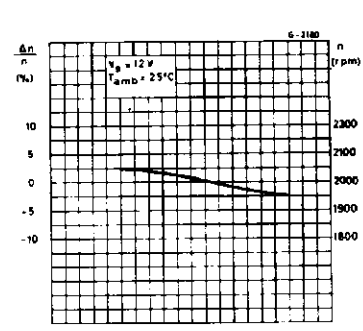
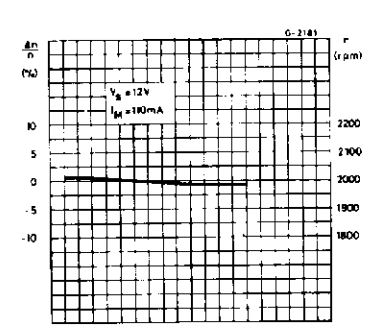
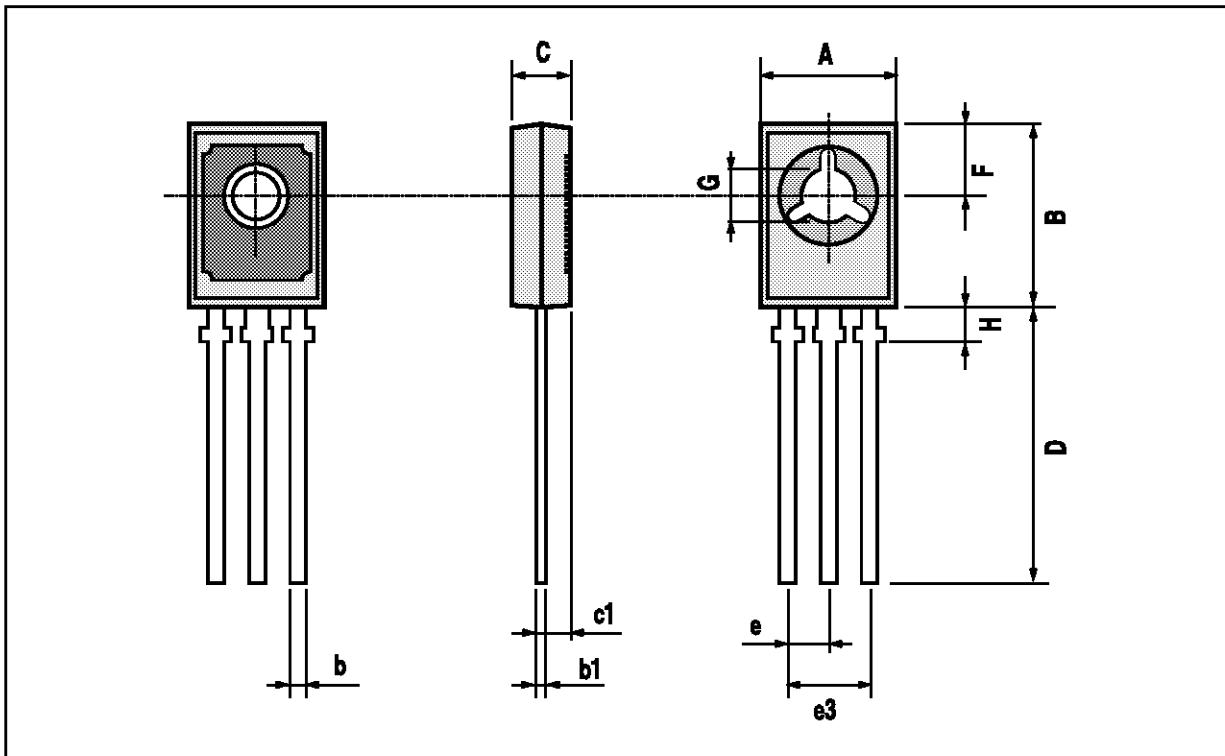

Figure 18. Speed variation vs. ambient temperature



SOT-32 PACKAGE MECHANICAL DATA

DIM.	mm			inch		
	MIN.	TYP.	MAX.	MIN.	TYP.	MAX.
A	7.4		7.8	0.291		0.307
B	10.5		10.8	0.413		0.425
b	0.7		0.9	0.028		0.035
b1	0.49		0.75	0.019		0.030
C	2.4		2.7	0.094		0.106
c1		1.2			0.047	
D		15.7			0.618	
e		2.2			0.087	
e3		4.4			0.173	
F		3.8			0.150	
G	3		3.2	0.118		0.126
H			2.54			0.100



Information furnished is believed to be accurate and reliable. However, SGS-THOMSON Microelectronics assumes no responsibility for the consequences of use of such information nor for any infringement of patents or other rights of third parties which may result from its use. No license is granted by implication or otherwise under any patent or patent rights of SGS-THOMSON Microelectronics. Specifications mentioned in this publication are subject to change without notice. This publication supersedes and replaces all information previously supplied. SGS-THOMSON Microelectronics products are not authorized for use as critical components in life support devices or systems without express written approval of SGS-THOMSON Microelectronics.

© 1994 SGS-THOMSON Microelectronics - All Rights Reserved

SGS-THOMSON Microelectronics GROUP OF COMPANIES

Australia - Brazil - France - Germany - Hong Kong - Italy - Japan - Korea - Malaysia - Malta - Morocco - The Netherlands - Singapore - Spain - Sweden - Switzerland - Taiwan - Thailand - United Kingdom - U.S.A.