

STEREO AMPLIFIER

- WIDE SUPPLY VOLTAGE RANGE (3 to 36V)
- SINGLE OR SPLIT SUPPLY OPERATION
- VERY LOW CURRENT CONSUMPTION (0.8mA)
- VERY LOW DISTORTION
- NO POP-NOISE

DESCRIPTION

The TDA2320A is a stereo class A preamplifier intended for application in portable cassette players and high quality audio systems.

The TDA2320A is a monolithic integrated circuit in a 8 lead plastic dip.

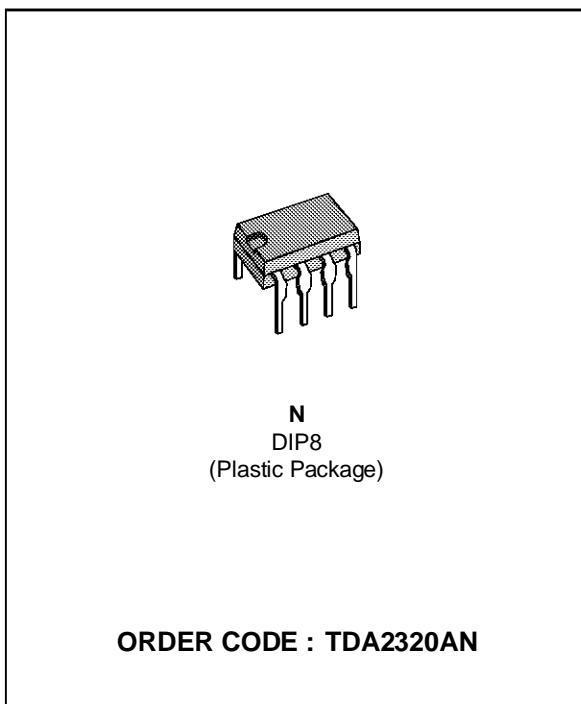

PIN CONNECTIONS (top view)

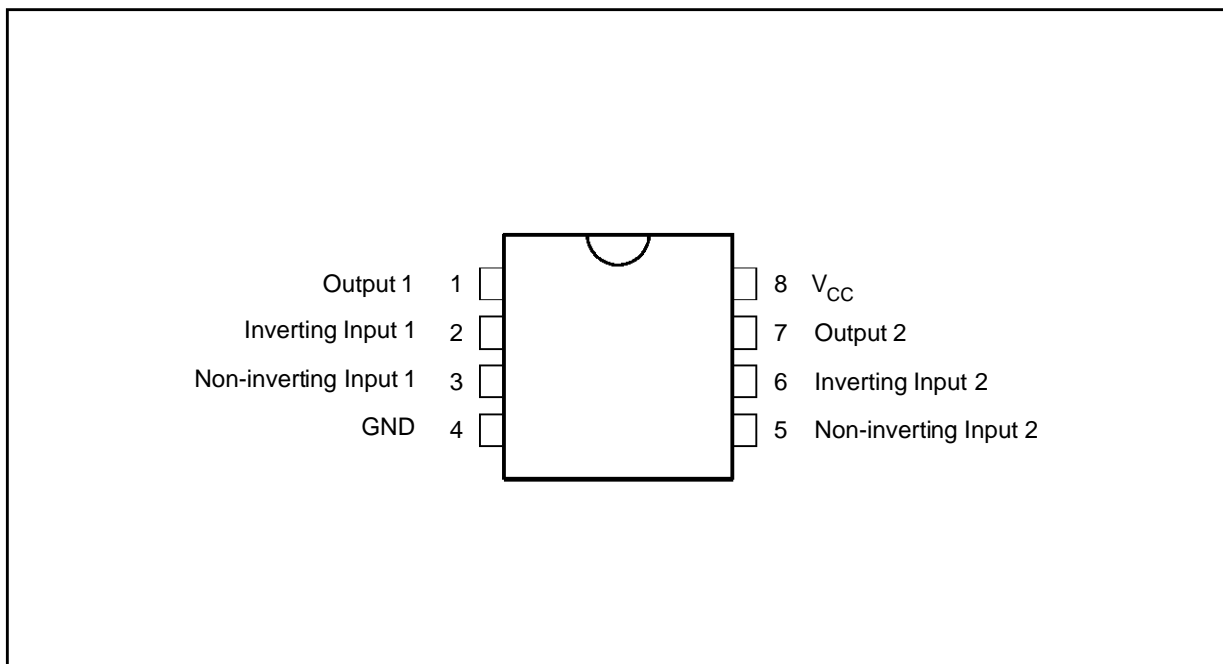

SCHEMATIC DIAGRAM (1/2 TDA2320A)

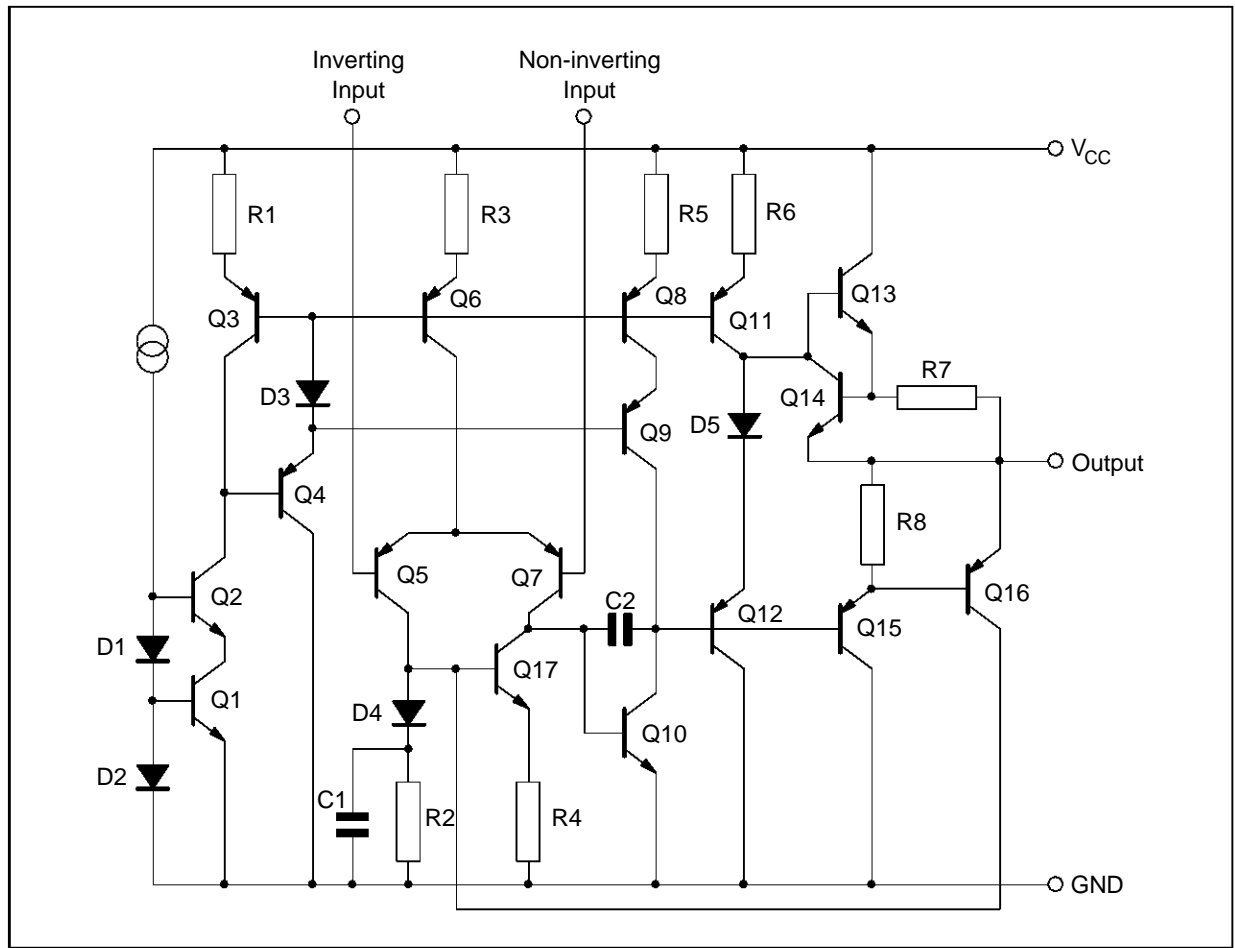

2320A-02.EPS

ABSOLUTE MAXIMUM RATINGS

Symbol	Parameter	Value	Unit
V _{CC}	Supply Voltage	36	V
P _{tot}	Total Power Dissipation at T _{amb} = 70°C	400	mW
T _{stg} , T _j	Storage and Junction Temperature	-40 to 150	°C

2320A-01.TBL

TDA2320A

TYPICAL APPLICATION

STEREO PREAMPLIFIER FOR CASSETTE PLAYERS

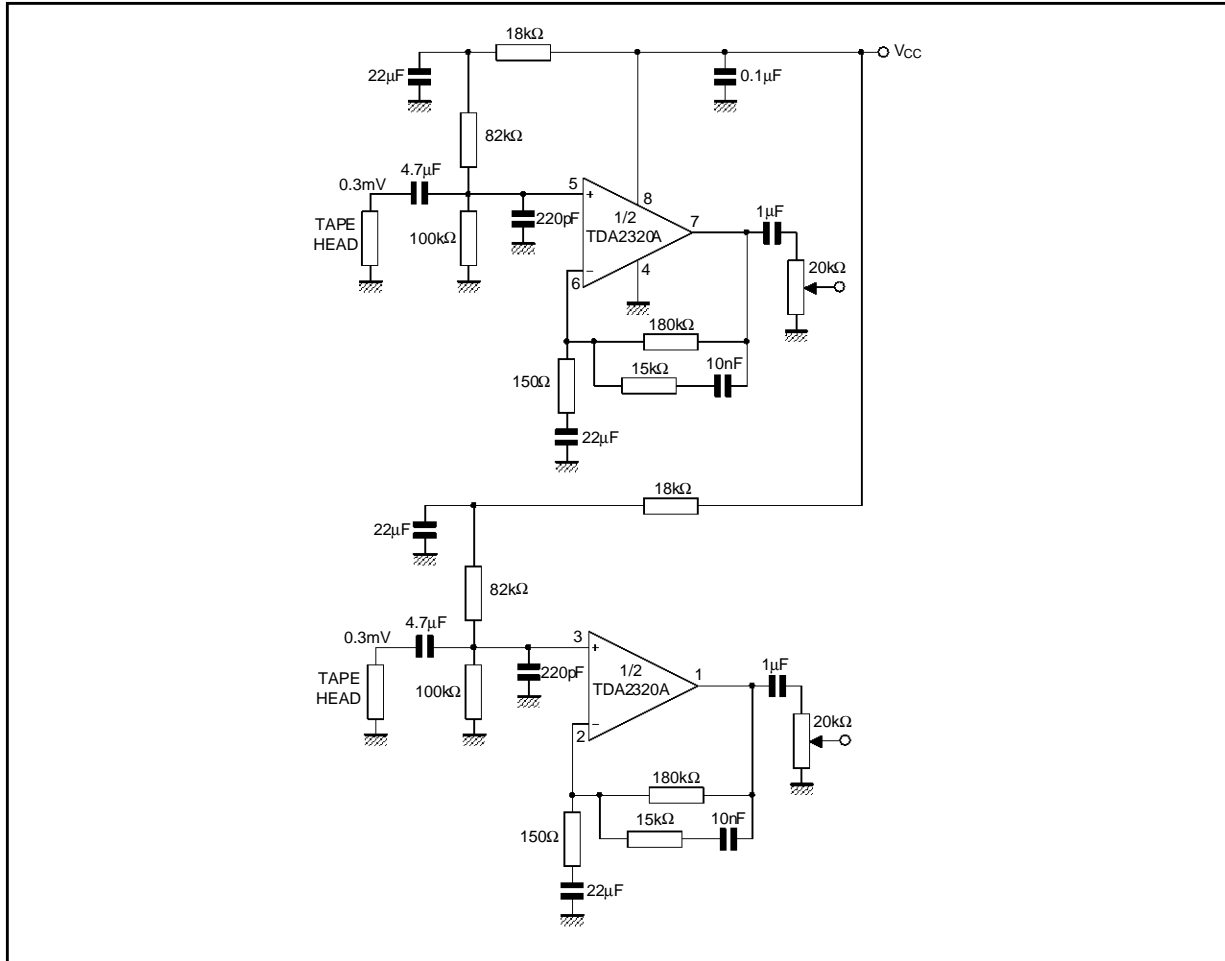

2320A-03.EPS

TEST CIRCUITS

Figure 1

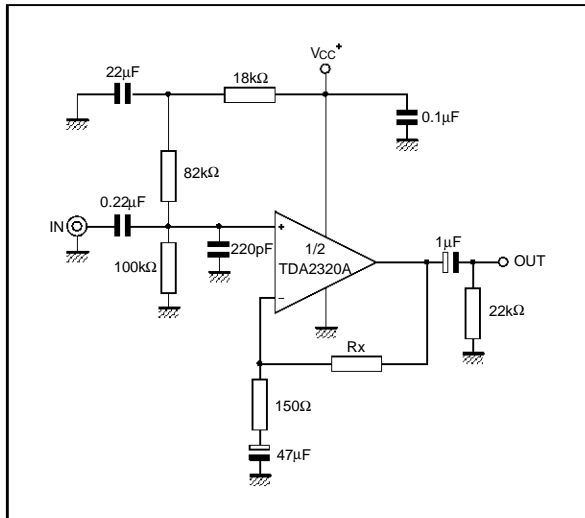

2320A-04.EPS

Figure 2

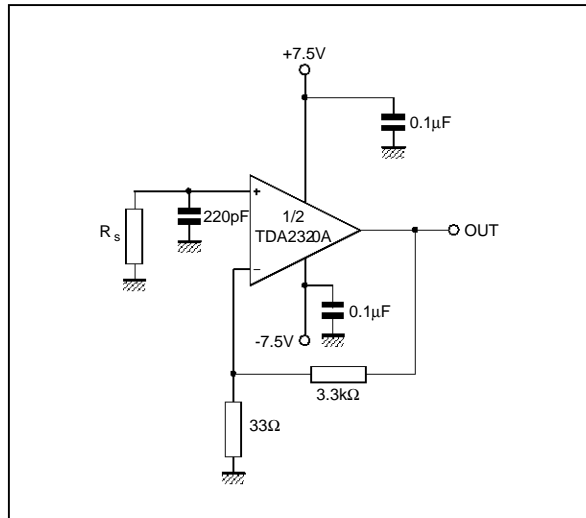

2320A-05.EPS

Figure 3 : Supply Current versus Supply Voltage

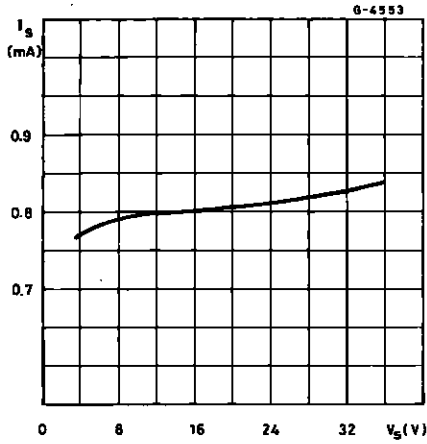

2320A-06.EPS

Figure 4 : Supply Current versus Ambient Temperature

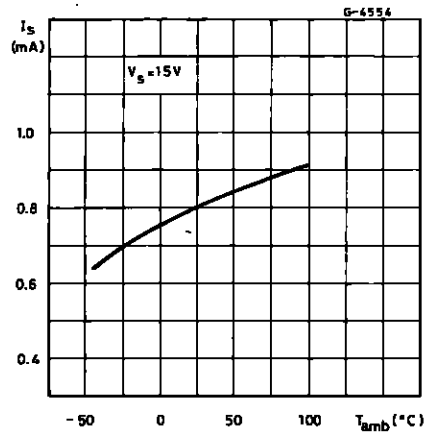

2320A-07.EPS

Figure 5 : Output Voltage Swing versus Load Resistance

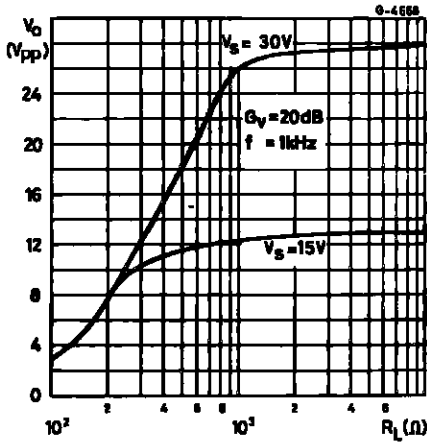

2320A-08.EPS

Figure 6 : Power Bandwidth

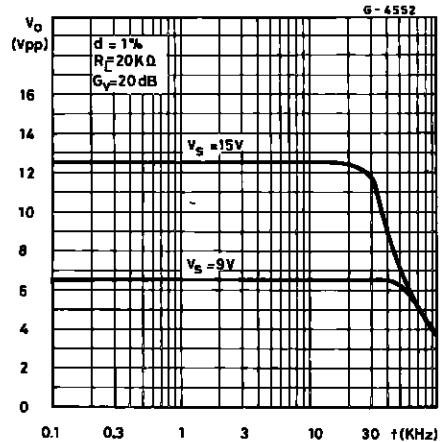

2320A-09.EPS

Figure 7 : Total Harmonic Distortion versus Output Voltage

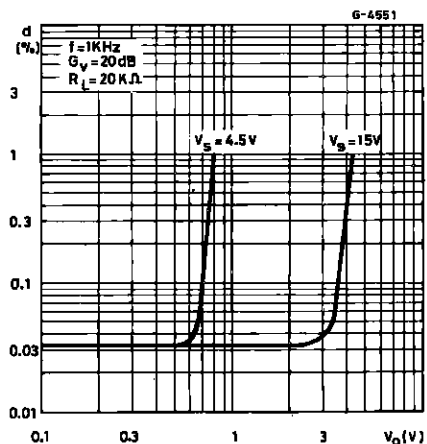

2320A-10.EPS

Figure 8 : Total Input Noise versus Source Resistance

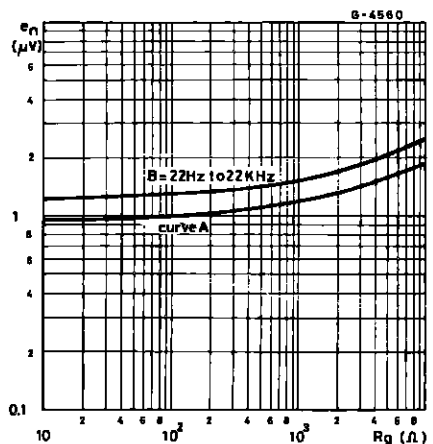

2320A-11.EPS

Figure 9 : Noise Density versus Frequency

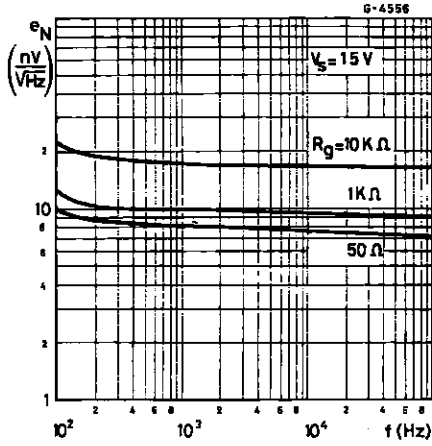

2320A-12.EPS

Figure 10 :RIAA Preamplifier Response

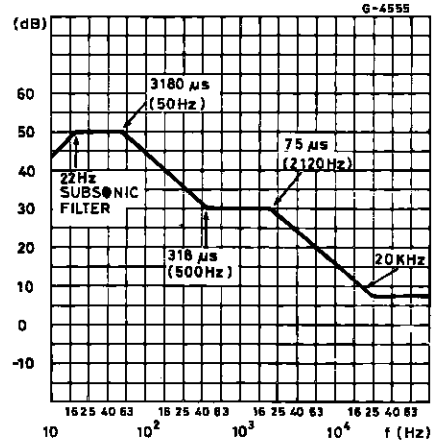

2320A-13.EPS

Figure 11 :Tape Preamplifier Frequency

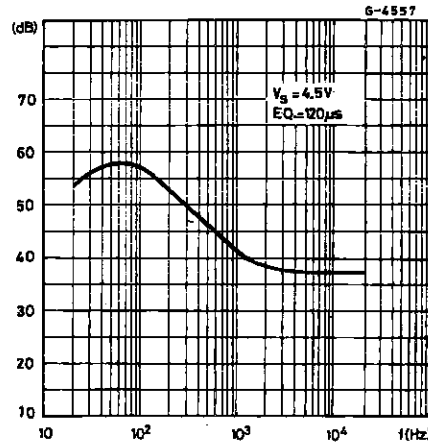

2320A-14.EPS

APPLICATION INFORMATION

Figure 12 : Stereo RIAA Preamplifier

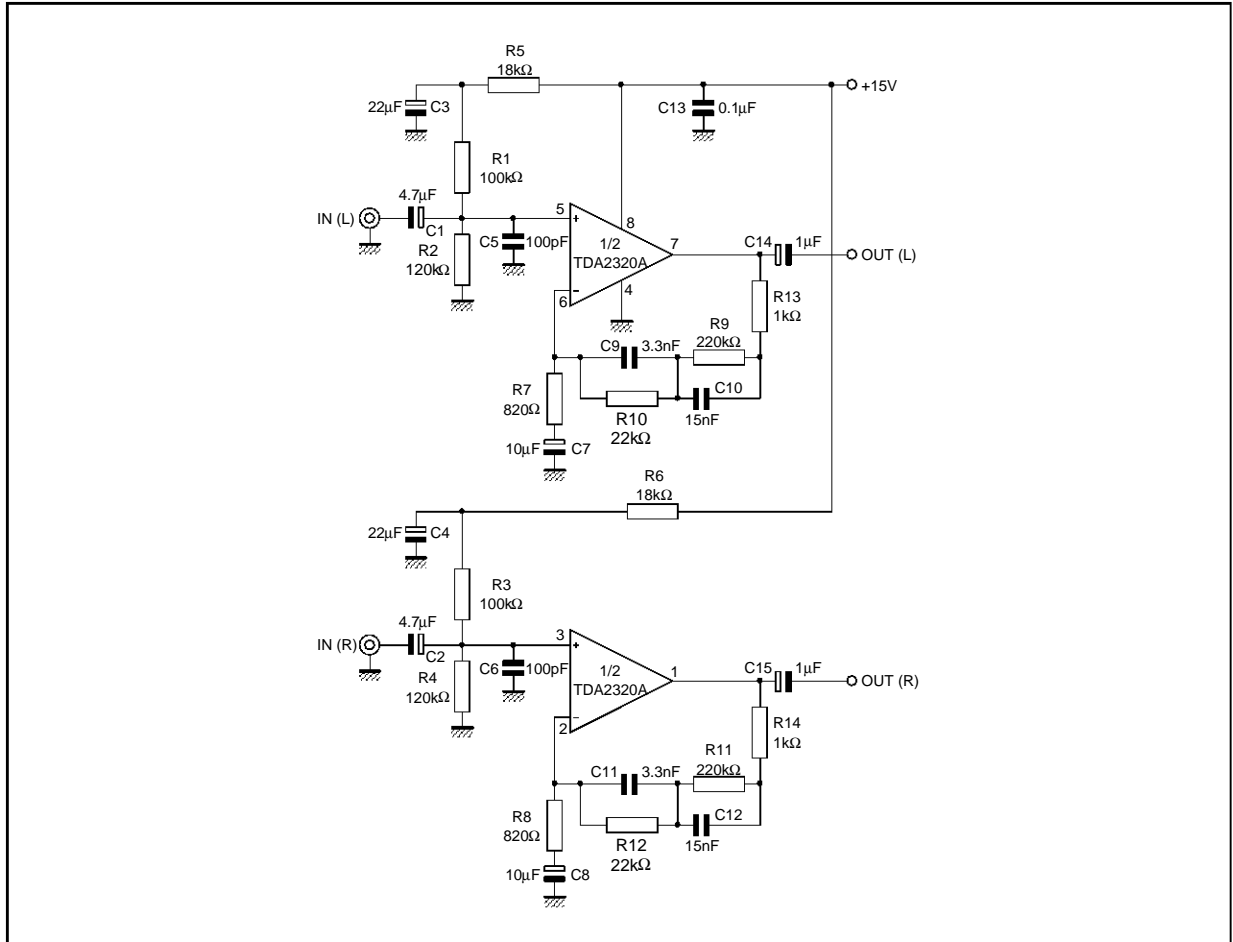

2320A-15.EPS

Figure 13 :P.C. Board and Components layout of the Circuit of figure 12

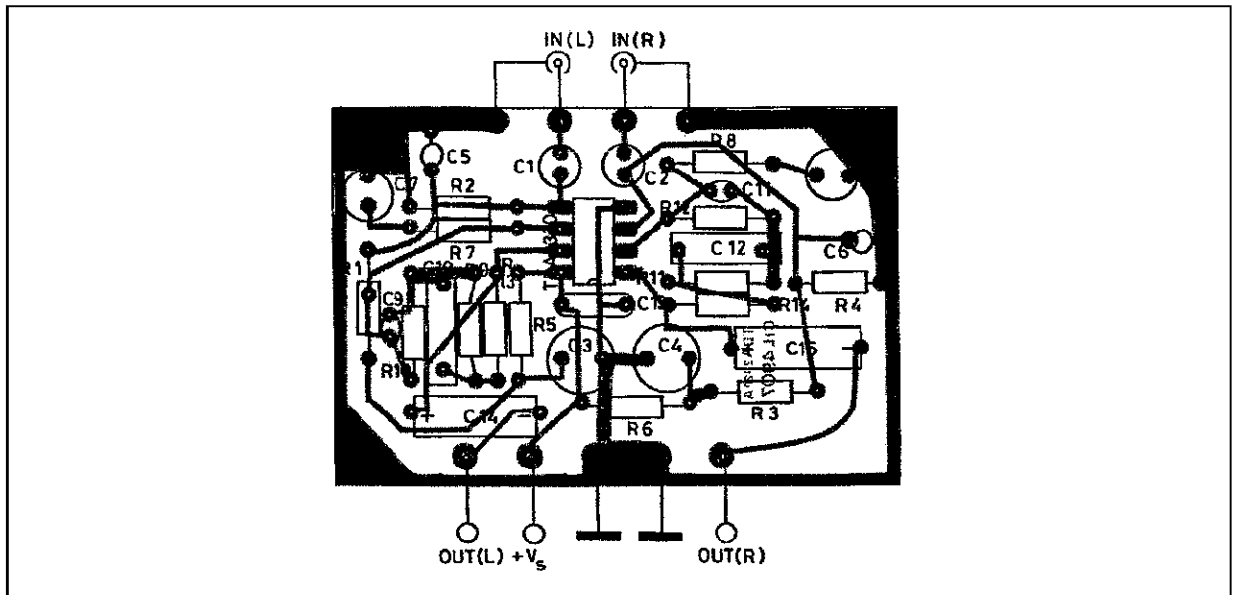

2320A-16.TIF

Figure 14 : Second Order 2kHz Butterworth Crossover Filter for Hi-Fi Active Boxes

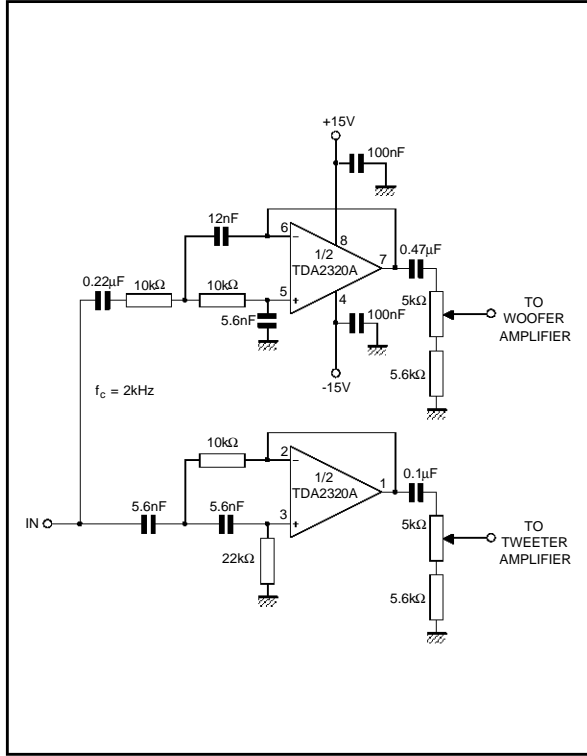

2320A-17.EPS

Figure 15 : Third Order 2.8kHz Bessel Crossover Filter for Hi-Fi Active Boxes

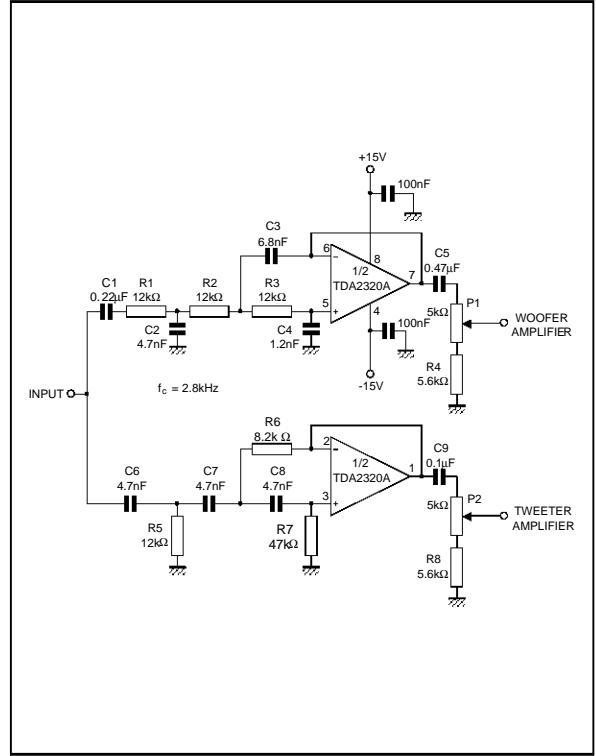

2320A-18.EPS

Figure 16 : Frequency Response (circuit of figure 14)

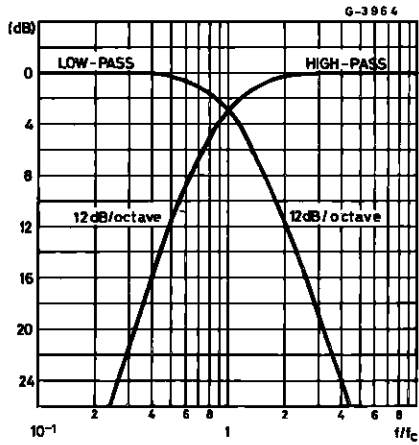

2320A-19.EPS

Figure 17 : Frequency Response (circuit of figure 15)

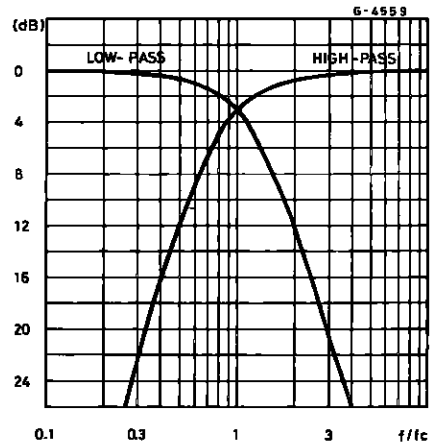

2320A-20.EPS

Figure 18 : 200Hz to 2kHz Active Bandpass Filter for Midrange Speakers

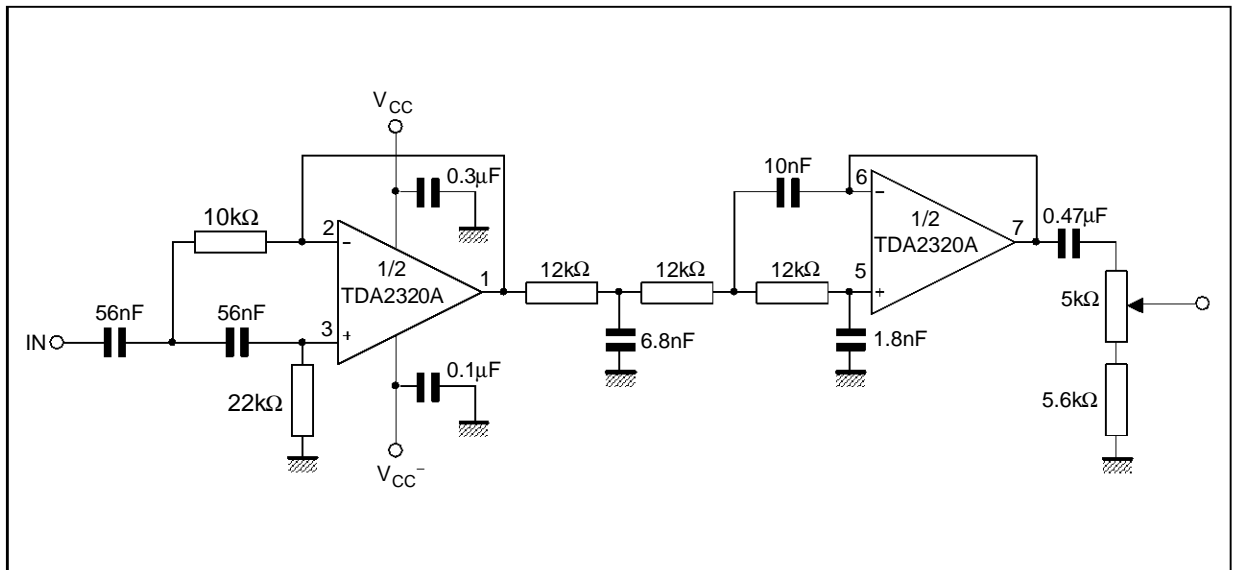

2320A-21.EPS

Figure 19 : Subsonic Filter

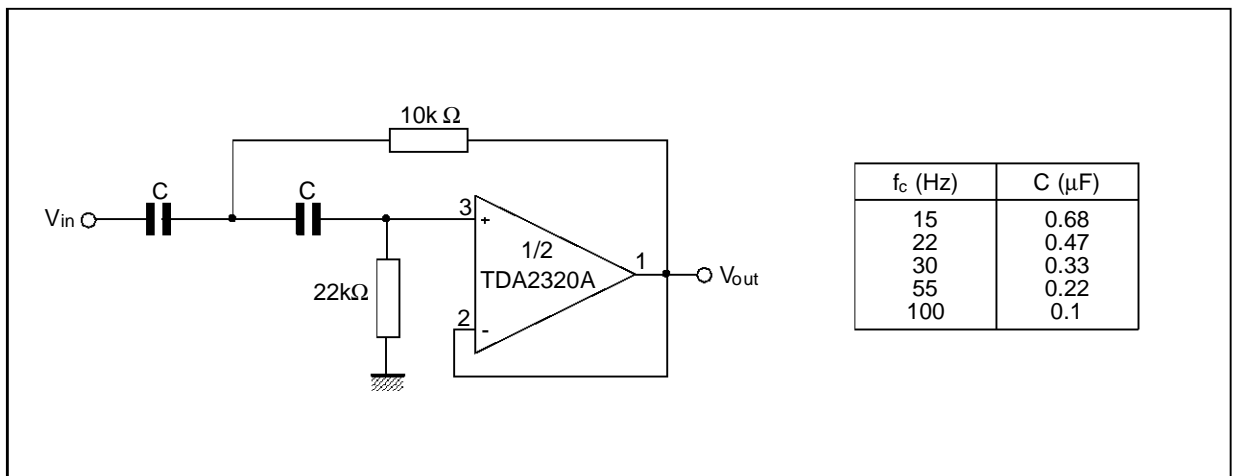

2320A-22.EPS

Figure 20 : High-cut Filter

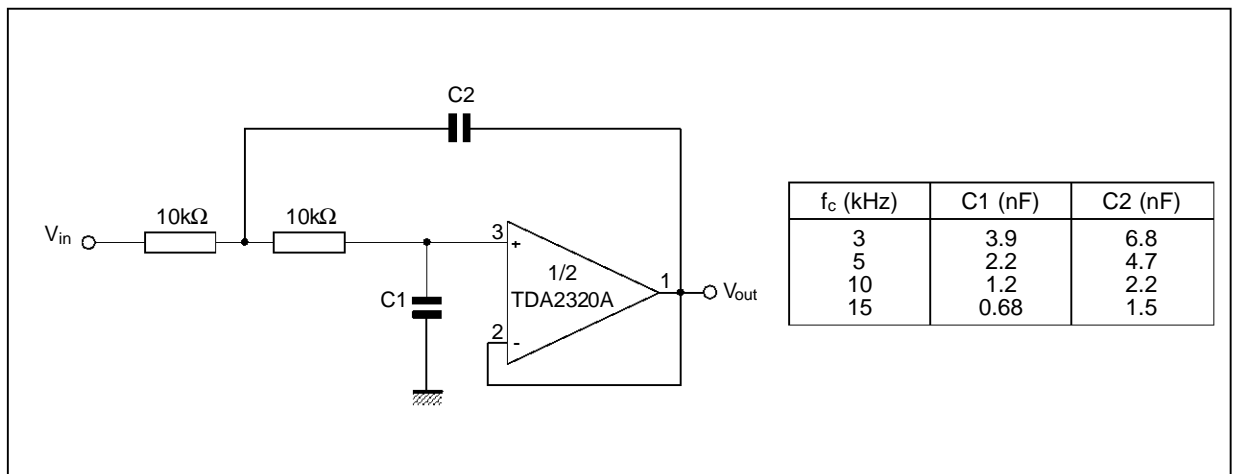

2320A-23.EPS

Figure 21 :Fifth Order 3.4kHz Low-pass Butterworth Filter

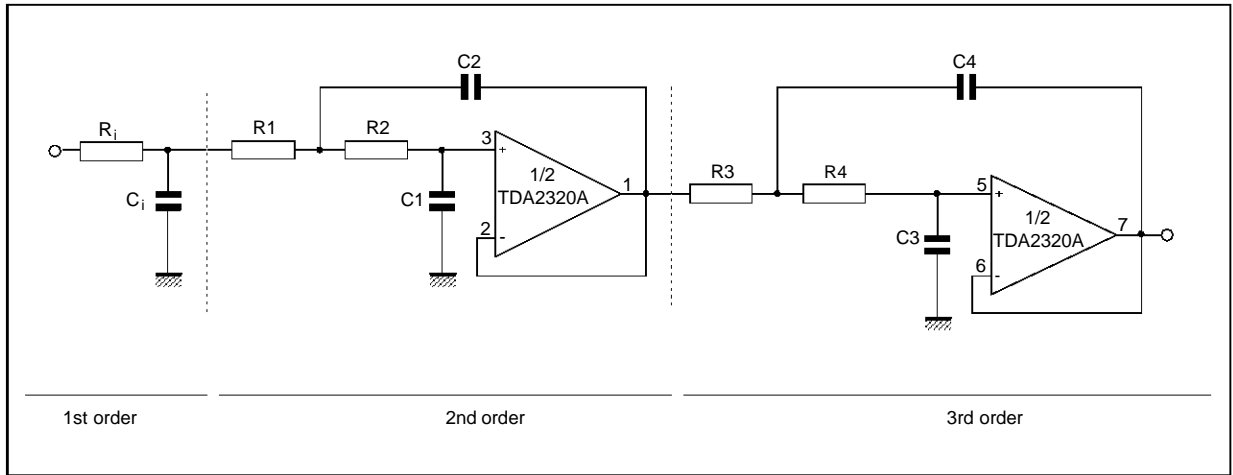

2320A-24.EPS

For $f_c = 3.4\text{kHz}$ and $R_i = R_1 = R_2 = R_3 = R_4 = 10\text{k}\Omega$, we obtain :

$$C_1 = 1.354 \cdot \frac{1}{R} \cdot \frac{1}{2\pi f_c} = 6.33\text{nF}$$

$$C_3 = 0.309 \cdot \frac{1}{R} \cdot \frac{1}{2\pi f_c} = 1.45\text{nF}$$

$$C_1 = 0.421 \cdot \frac{1}{R} \cdot \frac{1}{2\pi f_c} = 1.97\text{nF}$$

$$C_4 = 3.325 \cdot \frac{1}{R} \cdot \frac{1}{2\pi f_c} = 15.14\text{nF}$$

$$C_2 = 1.753 \cdot \frac{1}{R} \cdot \frac{1}{2\pi f_c} = 8.20\text{nF}$$

The attenuation of the filter is 30dB at 6.8kHz and better than 60dB at 15kHz.

Figure 22 :Sixth-pole 355Hz Low-pass Filter (Chebychev type)

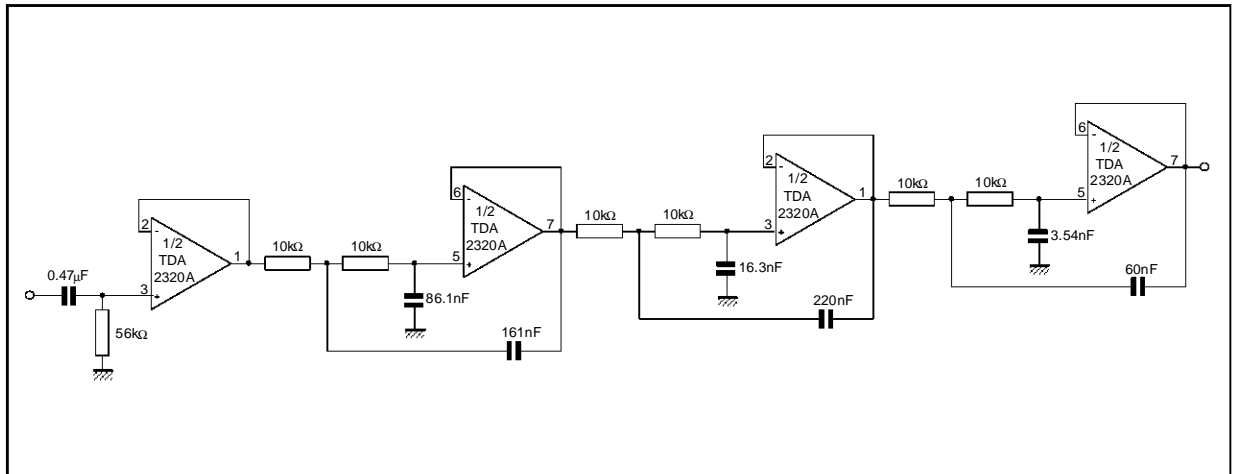

2320A-25.EPS

This is a 6-pole Chebyshev type with $\pm 0.25\text{dB}$ ripple in the passband. A decoupling stage is used to avoid the influence of the input impedance of the filter's characteristics.

The attenuation is about 55dB at 710Hz and reaches 80dB at 1065Hz. The in band attenuation is limited in practice to the $\pm 0.25\text{dB}$ ripple and does not exceed 1/2dB at $0.9f_c$.

Figure 23 : Three Band Tone Control

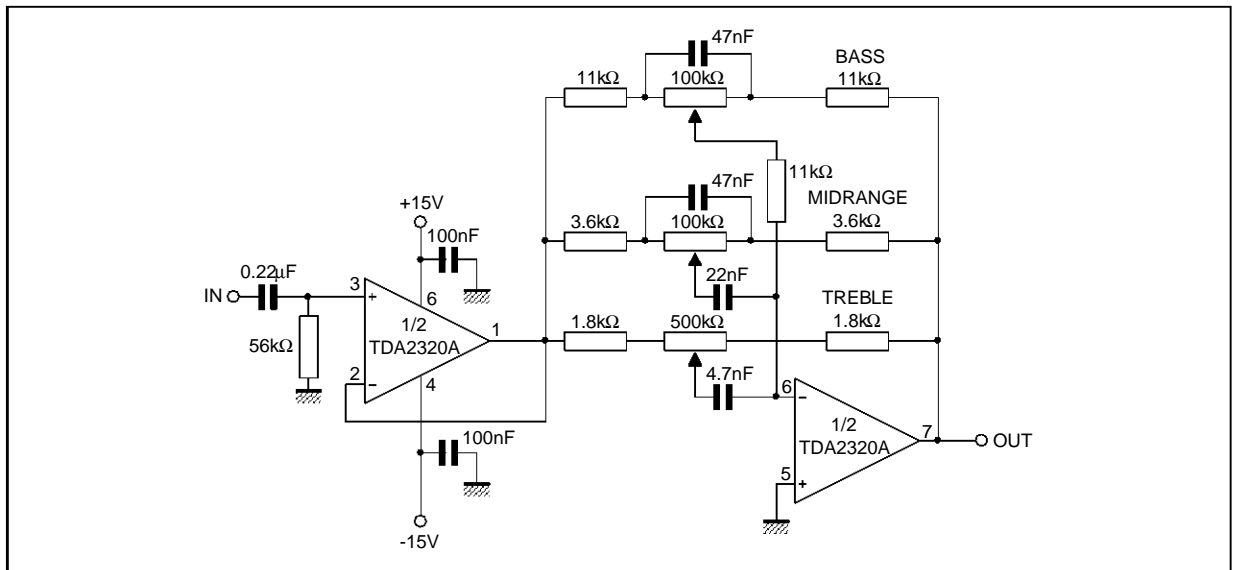

2320A-26.EPS

Figure 24 : Frequency Response of the Circuit of figure 23

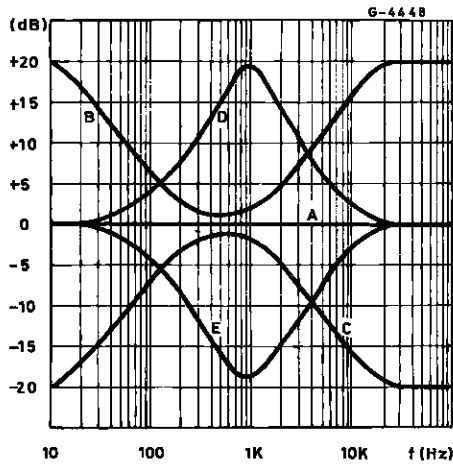

2320A-27.EPS

- A : all controls flat
- B : bass & treble boost, mid flat
- C : bass & treble cut, mid flat
- D : mid boost, bass & treble flat
- E : mid cut, bass treble flat

PACKAGE MECHANICAL DATA
8 PINS -PLASTIC DIP

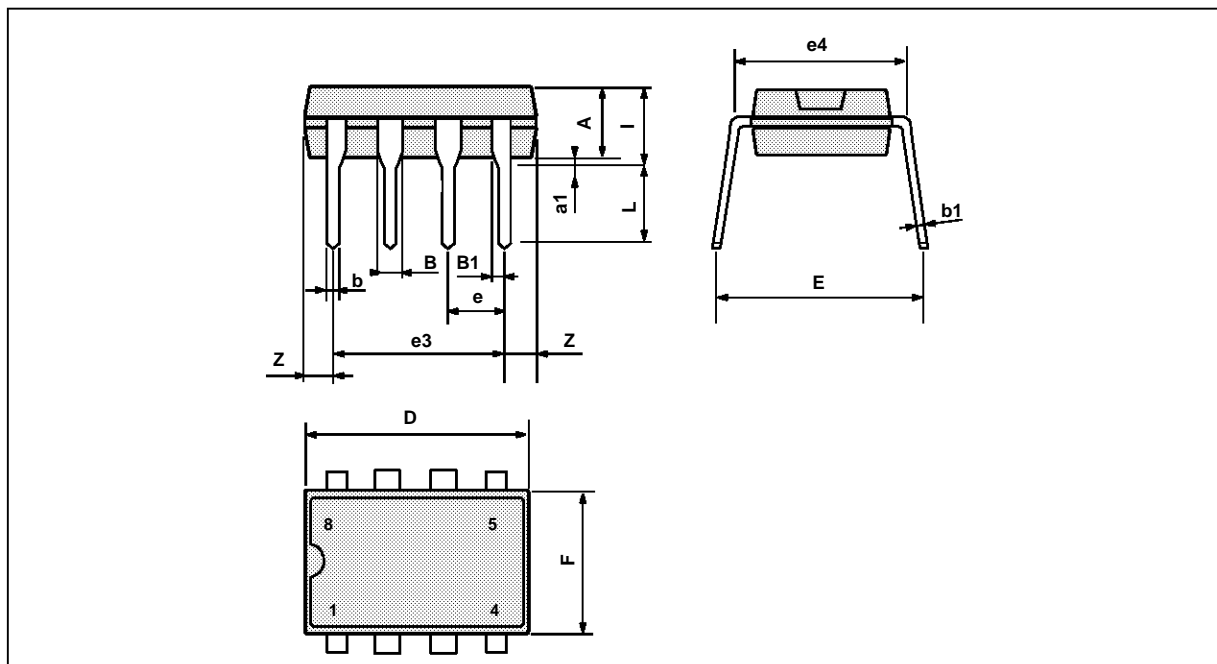

PM-DIP8.EPS

Dimensions	Millimeters			Inches		
	Min.	Typ.	Max.	Min.	Typ.	Max.
A		3.32			0.131	
a1	0.51			0.020		
B	1.15		1.65	0.045		0.065
b	0.356		0.55	0.014		0.022
b1	0.204		0.304	0.008		0.012
D			10.92			0.430
E	7.95		9.75	0.313		0.384
e		2.54			0.100	
e3		7.62			0.300	
e4		7.62			0.300	
F			6.6			0.260
i			5.08			0.200
L	3.18		3.81	0.125		0.150
Z			1.52			0.060

DIP8.TBL

Information furnished is believed to be accurate and reliable. However, SGS-THOMSON Microelectronics assumes no responsibility for the consequences of use of such information nor for any infringement of patents or other rights of third parties which may result from its use. No licence is granted by implication or otherwise under any patent or patent rights of SGS-THOMSON Microelectronics. Specifications mentioned in this publication are subject to change without notice. This publication supersedes and replaces all information previously supplied. SGS-THOMSON Microelectronics products are not authorized for use as critical components in life support devices or systems without express written approval of SGS-THOMSON Microelectronics.

© 1994 SGS-THOMSON Microelectronics - All Rights Reserved

SGS-THOMSON Microelectronics GROUP OF COMPANIES

Australia - Brazil - France - Germany - Hong Kong - Italy - Japan - Korea - Malaysia - Malta - Morocco - The Netherlands
Singapore - Spain - Sweden - Switzerland - Taiwan - Thailand - United Kingdom - U.S.A.

ORDER CODE :