

Am29117

A High-Performance 16-Bit Bipolar Microprocessor

PRELIMINARY

DISTINCTIVE CHARACTERISTICS

- **Optimized for High-Performance Controllers**
Architecture and instruction set optimized for high-performance, intelligent controllers
- **Flow-Through Architecture**
Separate input and output ports avoid bus turnaround for higher throughput
- **32 Working Registers**
Contains 32 working registers with latched outputs
- **Fast**
Supports 100 ns microcycle time/10 MHz data rate for all instructions
- **16-Bit Barrel Shifter**
Contains a 16-bit Barrel Shifter which can shift or rotate a word up to 15 positions in a single instruction cycle
- **68-Pin Pin Grid Array Package**

GENERAL DESCRIPTION

The Am29117 is a microprogrammable 16-bit bipolar microprocessor whose architecture and instruction set are identical to the Am29116's except for the I/O bus structure. Since the device has separate input and output ports, designers can avoid quick bus turnaround requirements.

The architecture and instruction set are not only optimized for high-performance peripheral controllers, but also suitable for microprogrammed processor applications when combined with the Am29517A 16 x 16 Multiplier.

The instruction set contains unique functions besides ordinary logic and arithmetic functions: bit manipulation instructions (set, reset and test), rotate merge/compare instructions, prioritize instruction and CRC instruction.

BLOCK DIAGRAM

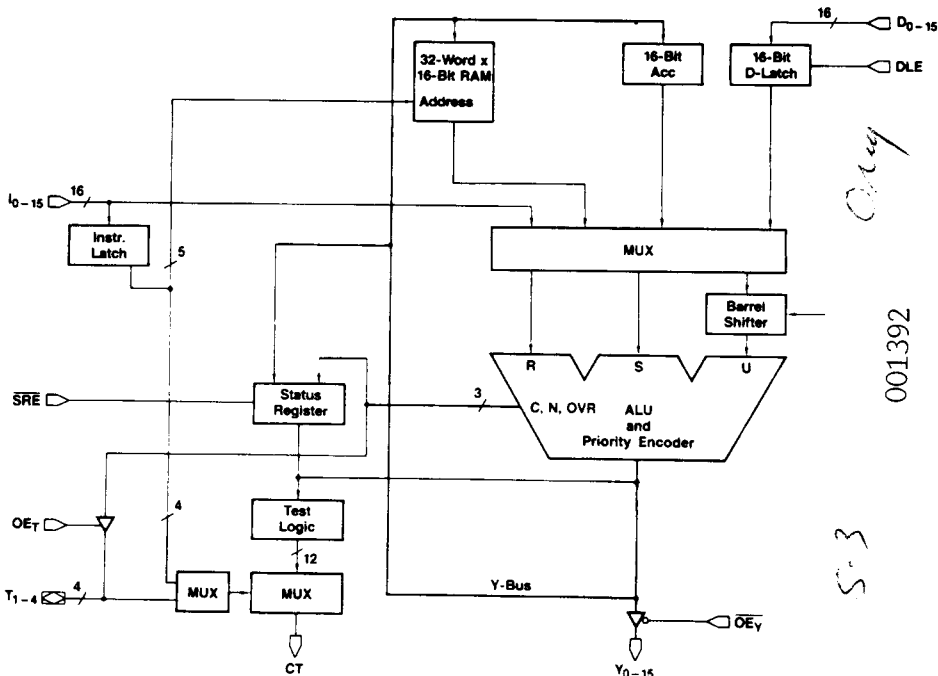

BD001972

Am29117

Advanced Micro Devices

November 1985

CONNECTION DIAGRAM*

PIN GRID ARRAY

Bottom View

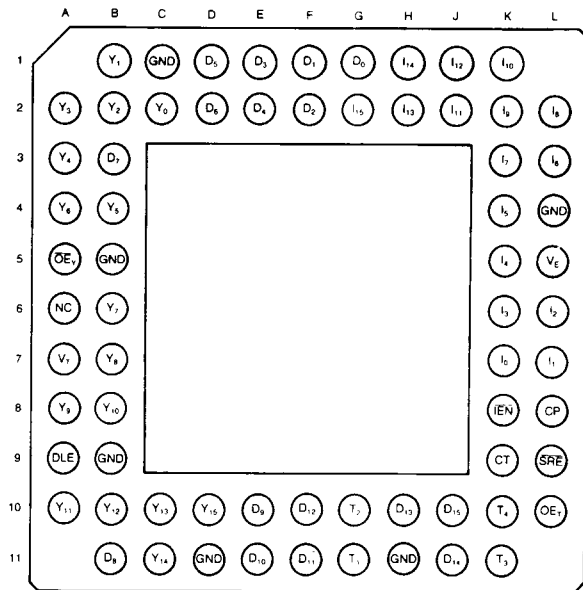

CD009021

Note: Notch indicates orientation.

*Available in 68-pin ceramic LCC

METALLIZATION AND PAD LAYOUT

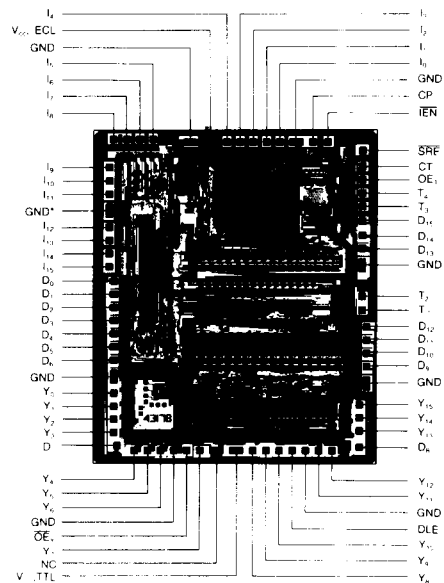

* These GND pads are internally connected inside the package, therefore they do not have external pin numbers.

ORDERING INFORMATION

Standard Products

AMD products are available in several packages and operating ranges. The order number (Valid Combination) is formed by a combination of:

- A. Device Number**
- B. Speed Option** (if applicable)
- C. Package Type**
- D. Temperature Range**
- E. Optional Processing**

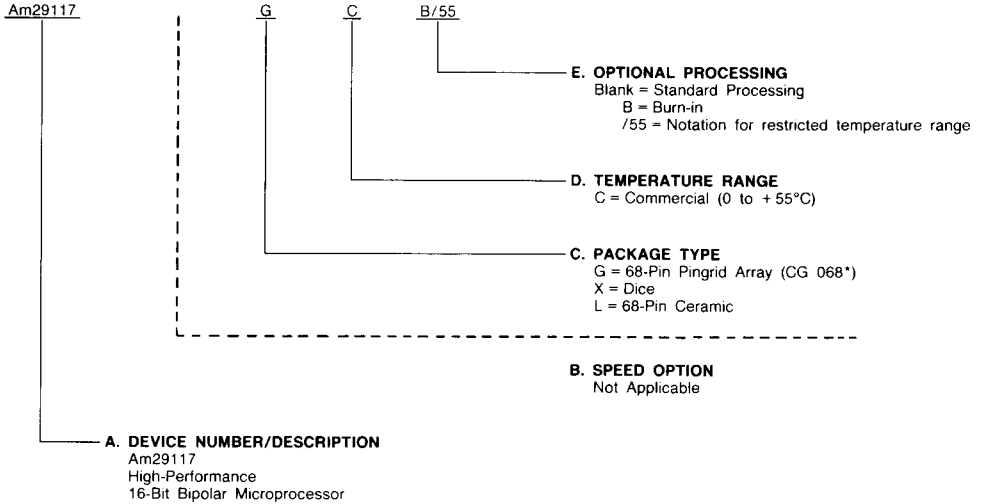

*Preliminary. Subject to Change.

Valid Combinations	
Am29117	GC/55, LC/55 GCB/55, XC/55

Valid Combinations

Consult the local AMD sales office to confirm availability of specific valid combinations, to check on newly released valid combinations, and to obtain additional data on AMD's standard military grade products.

PIN DESCRIPTION

D₀ – D₁₅ Bidirectional Data (Input)

Data Input Lines, D₀ – D₁₅, are used as external data inputs which allow data to be directly loaded into the 16-bit data latch.

Y₀ – Y₁₅ General Output (Output)

Data Output lines. When \overline{OE}_Y is HIGH, the 16-bit Y outputs are disabled (high impedance); having \overline{OE}_Y LOW allows the ALU data to be output on Y₀ – Y₁₅.

DLE Data Latch Enable (Input)

When \overline{OE}_Y is HIGH, the 16-bit data latch is transparent and is latched when DLE is LOW.

\overline{OE}_Y Output Enable (Input)

When \overline{OE}_Y is HIGH, the 16-bit Y outputs are disabled (high impedance); when \overline{OE}_Y is LOW, the 16-bit Y outputs are enabled (HIGH or LOW).

I₀ – I₁₅ Instruction Inputs (Input)

Sixteen Instruction Inputs, used to select the operation to be performed in the Am29117. Also used as data inputs while performing immediate instructions.

\overline{IEN} Instruction Enable (Input)

When \overline{IEN} is LOW, data can be written into RAM when the clock is LOW. The Accumulator can accept data during the LOW-to-HIGH transition of the clock. Having \overline{IEN} LOW, the Status Register can be updated when \overline{SRE} is LOW. With \overline{IEN} is HIGH, the conditional test output, CT, is disabled as a function of the instruction inputs.

\overline{SRE} Status Register Enable (Input)

When \overline{SRE} and \overline{IEN} are both LOW, the Status Register is

updated at the end of all instructions with the exception of NO-OP, Save Status and Test Status. Having either \overline{SRE} or \overline{IEN} HIGH will inhibit the Status Register from changing.

CP Clock Pulse (Input)

The clock input to the Am29117. The RAM latch is transparent when the clock is HIGH. When the clock goes LOW, the RAM output is latched. Data is written into the RAM during the LOW period of the clock, provided \overline{IEN} is LOW, and if the instruction being executed designates the RAM as the destination of operation. The Accumulator and Status Register will accept data on the LOW-to-HIGH transition of the clock if \overline{IEN} is also LOW. The instruction latch becomes transparent when it exits an immediate instruction mode during a LOW-to-HIGH transition of the clock.

T₁ – T₄ Test I/O Pins (Input/Output)

Under the control of OE_T , the four lower status bits, Z, C, N and OVR become outputs on T₁ – T₄, respectively, when OE_T goes HIGH. When OE_T is LOW, T₁ – T₄ are used as inputs to generate the CT output.

OE_T Output Enable (Output)

When OE_T is LOW, 4-bit T outputs are disabled (high impedance); when OE_T is HIGH, the 4-bit T outputs are enabled (HIGH or LOW).

CT Conditional Test (Output)

The condition code multiplexer selects one of the twelve condition code signals and places it on the CT output. A HIGH on the CT output indicates a passed condition and a LOW indicates a failed condition.

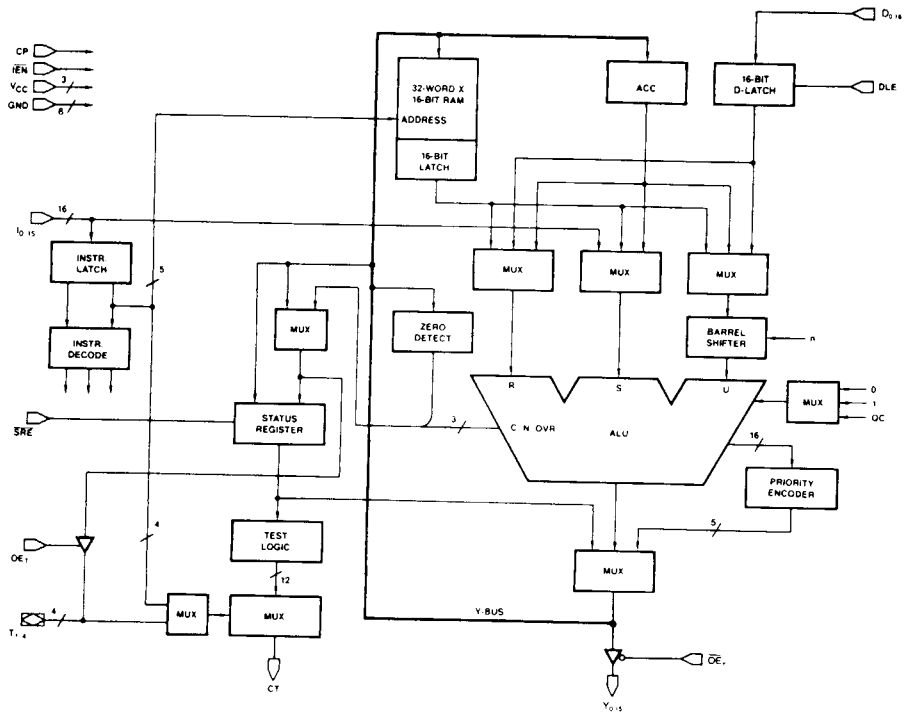

BD001961

Figure 1. Detailed Block Diagram

FUNCTIONAL DESCRIPTION

Architecture of the Am29117

The Am29117 is a high-performance, microprogrammable 16-bit bipolar microprocessor.

As shown in the Detailed Block Diagram (Figure 1), the device consists of the following elements interconnected with 16-bit data paths.

- 32-Word by 16-Bit RAM
- Accumulator
- Data Latch
- Barrel Shifter
- Arithmetic Logic Unit (ALU)
- Priority Encoder
- Status Register
- Condition-Code Generator/Multiplexer
- Three-State Output Buffers
- Instruction Latch and Decoder

32-Word by 16-Bit RAM

The 32-Word by 16-Bit RAM is a single-port RAM with a 16-bit latch at its output. The latches are transparent when the clock input (CP) is HIGH and latched when the clock input is LOW. Data is written into the RAM while the clock is LOW if the \overline{IEN} input is also LOW and if the instruction being executed defines the RAM as the destination of the operation. For byte instructions, only the lower eight RAM bits are written into; for word instructions, all 16 bits are written into. With the use of an external multiplexer on five of the instruction inputs, it is possible to select separate read and write addresses for the same instruction. This two-address operation is not allowed for immediate instructions.

Accumulator

The 16-bit Accumulator is an edge-triggered register. The Accumulator accepts data on the LOW-to-HIGH transition of the clock input if the \overline{IEN} input is LOW and if the instruction being executed defines the Accumulator as the destination of the operation. For byte instructions, only the lower eight bits of the Accumulator are written into; for word instructions, all 16 bits are written into.

Data Latch

The 16-bit Data Latch holds the data input to the Am29117 on the D bus. The latch is transparent when the DLE input is HIGH and latched when the DLE input is LOW.

Barrel Shifter

A 16-bit Barrel Shifter is used as one of the ALU inputs. This permits rotating data from either the RAM, the Accumulator or the Data Latch up to 15 positions. In the word mode, the Barrel Shifter rotates a 16-bit word; in the byte mode, it rotates only the lower eight bits.

Arithmetic Logic Unit

The Am29117 contains a 16-bit ALU with full carry lookahead across all 16 bits in the arithmetic mode. The ALU is capable of operating on either one, two or three operands, depending upon the instruction being executed. It has the ability to execute all conventional one and two operand operations, such as pass, complement, two's complement, add, subtract, AND, NAND, OR, NOR, EXOR, and EX-NOR. In addition, the ALU can also execute three-operand instructions such as rotate and merge and rotate and compare with mask. All ALU operations can be performed on either a word or byte basis, byte operations being performed on the lower eight bits only.

The ALU produces three status outputs, C (carry), N (negative) and OVR (overflow). The appropriate flags are generated at

the byte or word level, depending upon whether the device is executing in the byte or word mode. The Z (zero) flag, although not generated by the ALU, detects zero at both the byte and word level.

The carry input to the ALU is generated by the Carry Multiplexer which can select an input of zero, one, or the stored carry bit from the Status Register, QC. Using QC as the carry input allows execution of multiprecision addition and subtractions.

Priority Encoder

The Priority Encoder produces a binary-weighted code to indicate the locations of the highest order ONE at its input. The input to the Priority Encoder is generated by the ALU which performs an AND operation on the operand to be prioritized and a mask. The mask determines which bit locations to eliminate from prioritization. In the word mode, if no bit is HIGH, the output is a binary zero. If bit 15 is HIGH, the output is a binary one. Bit 14 produces a binary two, etc. Finally, if only bit 0 is HIGH, a binary 16 is produced.

In the byte mode, bits 8 thru 15 do not participate. If none of bits 7 thru 0 are HIGH, the output is a binary zero. If bit 7 is HIGH a binary one is produced. Bit 6 produces a binary two, etc. Finally, if only bit 0 is HIGH, a binary 8 is produced.

Status Register

The Status Register holds the 8-bit status word. With the Status-Register Enable, (\overline{SRE}) input LOW and the \overline{IEN} input LOW, the Status Register is updated at the end of all instructions except NO-OP, Save-Status and Test-Status instructions. \overline{SRE} going HIGH or \overline{IEN} going HIGH inhibits the Status Register from changing.

The lower four bits of the Status Register contain the ALU status bits of Zero (Z), Carry, (C) Negative (N), and Overflow (OVR). The upper four bits contain a Link bit and three user-definable status bits (Flag 1, Flag 2, Flag 3).

With \overline{SRE} LOW and \overline{IEN} LOW, the lower four status bits are updated after each instruction except those mentioned above, NO-OP, Save Status, Status Test and the Status Set/Reset instruction for the upper four bits. Under the same conditions, the upper four status bits are changed only during their respective Status Set/Reset instructions and during Status Load instructions in the word mode. The Link-Status bit is also updated after each shift instruction.

The Status Register can be loaded from the internal Y-bus, and can also be selected as a source for the internal Y-bus. When the Status Register is loaded in the word mode, all 8-bits are updated; in the byte mode, only the lower 4 bits (Z, C, N, OVR) are updated.

When the Status Register is selected as a source in the word mode, all eight bits are loaded into the lower byte of the destination; the upper byte of the destination is loaded with all zeros. In the byte mode, the Status Register again loads into the lower byte of the destination, but the upper byte remains unchanged. This Store and Load combination allows saving the restoring the Status Register for interrupt and subroutine processing. The four lower status bits (Z, C, N, OVR) can be read directly via the bidirectional T bus. These four bits are available as outputs on the T_{1-4} outputs whenever OE_T is HIGH.

Condition-Code Generator/Multiplexer

The Condition-Code Generator/Multiplexer contains the logic necessary to develop the 12 condition-code test signals. The multiplexer portion can select one of these test signals and place it on the CT output for use by the microprogram sequence. The multiplexer may be addressed in two different

ways. One way is through the Test Instruction. This instruction specifies the test condition to be placed in the CT output, but does not allow an ALU operation at the same time. The second method uses the bidirectional T bus as an input. This requires extra bits in the microword, but provides the ability to simultaneously test and execute. The test instruction lines, I₀₋₄, have priority over T₁₋₄, for testing status.

Three-State Output Buffers

There are two sets of Three-State Output Buffers in the Am29117. One set controls the 16-bit Y bus. These outputs are enabled by placing a LOW on the \overline{OE}_Y input. A HIGH puts the Y outputs in the high-impedance state, allowing data to be input to the Data latch from an external source.

The second set of Three-State Output Buffers controls the bidirectional 4-bit T bus and is enabled by placing a HIGH on the OE_T input. This allows storing the four internal ALU status bits (Z, C, N, OVR) externally. A LOW OE_T input forces the T outputs into the high-impedance state. External devices can

then drive the T bus to select a test condition for the CT output.

Instruction Latch and Decoder

The 16-bit Instruction Latch is normally transparent to allow decoding of the Instruction Inputs by the Instruction Decoder into the internal control signals for the Am29117. All instructions except Immediate Instructions are executed in a single clock cycle.

Immediate instructions require two clock cycles for execution. During the first clock cycle, the Instruction Decoder recognizes that an Immediate Instruction is being specified and captures the data on the Instruction Inputs in the Instruction Latch. During the second clock cycle, the data on the Instruction Inputs is used as one of the operands for the function specified during the first clock cycle. At the end of the second clock cycle, the Instruction Latch is returned to its transparent state.

Instruction Set

The instruction set of the Am29117 is very powerful. In addition to the single and two operand logical and arithmetic instructions, the Am29117 instruction set contains functions particularly useful in controller applications: bit set, bit reset, bit test, rotate and merge, rotate and compare, and cyclic-redundancy-check (CRC) generation. Complex instructions.

Three data types are supported by the Am29116.

- Bit
- Byte
- Word (16-bit)

In the byte mode data is written into the lower half of the word and the upper half is unchanged. The special case is when the status register is specified as the destination. In the byte mode the LSH (OVR, N, C, Z) of the status register is updated and in the word mode all eight bits of the status register are updated. The status register does not change for save status and test status instructions. In the test status instructions the CT output has the result and the Y-bus is undefined.

The Am29117 Instruction Set can be divided into eleven types of instructions. These are:

- Single Operand
- Two Operand
- Single Bit Shift
- Rotate and Merge
- Bit Oriented
- Rotate by n Bits
- Rotate and Compare
- Prioritize
- Cyclic-Redundancy-Check
- Status
- No-Op

Each instruction type is arbitrarily divided into quadrants. Two of the sixteen instruction lines decode to four quadrants labelled from 0 to 3. The quadrants were defined mainly for convenience in classification of the instruction set and addressing modes and can be used together with the OP CODES to distinguish the instructions.

The following pages describe each of the instruction types in detail. Table 1 illustrates Operand Source-Destination Combinations for each instruction type.

TABLE 1. OPERAND SOURCE-DESTINATION COMBINATIONS

Instruction Type	Operand Combinations (Note 1)		
	Source (R/S)		Destination
Single Operand	RAM (Note 2)		RAM
	ACC		ACC
	D		Y Bus
	D(0E)		Status
	D(SE)		ACC and Status
Two Operand	Source (R)	Source (S)	Destination
	RAM	ACC	RAM
	RAM	I	ACC
	D	RAM	Y Bus
	D	ACC	Status
Single Bit Shift	Source (U)		Destination
	RAM		RAM
	ACC		ACC
	ACC		Y Bus
	D		RAM
Rotate n Bits	Source (U)		Destination
	RAM		RAM
	ACC		ACC
	D		Y Bus
	Bit Oriented	Source (R/S)	
RAM		RAM	
ACC		ACC	
Rotate and Merge	Rotated Source (U)	Mask (S)	Non-Rotated Source/ Destination (R)
	D	I	ACC
	D	RAM	ACC
	D	I	RAM
	D	ACC	RAM
Rotate and Compare	Rotated Source (U)	Mask (S)	Non-Rotated Source/ Destination (R)
	D	I	RAM
	D	I	RAM
	D	ACC	RAM
	RAM	I	ACC

Instruction Type	Operand Combinations (Note 1)		
	Source (R)	Mask (S)	Destination
Prioritize (Note 3)	RAM	RAM	RAM
	ACC	ACC	ACC
	D	I	Y Bus
Cyclic Redundancy Check	Data In	Destination	Polynomial
	QLINK	RAM	ACC
No Operation	-		
Set Reset Status	Bits Affected		
	OVR, N, C, Z		
	LINK		
	Flag1 Flag2 Flag3		
Store Status	Source	Destination	
	Status	RAM ACC Y Bus	
Status Load	Source (R)	Source (S)	Destination
	D	ACC	Status
	ACC	I	Status and ACC
Test Status	Test Condition (CT)		
	$(N \oplus OVR) + Z$		
	$N \oplus OVR$		
	Z		
	OVR		
Low			
C			
$Z + \bar{C}$			
N			
LINK			
Flag 1			
Flag 2			
Flag 3			

- Notes: 1. When there is no dividing line between the R&S OPERAND or SOURCE and DESTINATION, the two must be used as a given pair. But where there exists such a separation, any combination of them is possible.
2. In the SINGLE OPERAND INSTRUCTION, RAM cannot be used when both ACC and STATUS are designated as a DESTINATION.
3. In the PRIORITIZE INSTRUCTION, OPERAND and MASK must be different sources.

Single Operand Instructions

The Single Operand Instructions contain four indicators: byte or word mode, opcode, source and destination. They are further subdivided into two types. The first type uses RAM as a source or destination or both, and the second type does not use RAM as a source or destination. Both types have different instruction formats as shown below. Under the control of instruction inputs, the desired function is performed on the source and the result is either stored in the specified destination or placed on the Y-bus or both. For a special case where

8-bit to 16-bit conversion is needed, the Am29117 is capable of extending sign bit (D(SE)) or binary zero (D(0E)) over 16-bits in the word mode. The least significant four bits of the Status Register (OVR, N, C, Z) are affected by the function performed in this category. The most significant bits of status register (FLAG1, FLAG2, FLAG3, LINK) are not affected. The only limitation in this type is that the RAM cannot be used as a source when both ACC and the Status Register are specified as a destination.

SINGLE OPERAND FIELD DEFINITIONS

	15	14	13	12	9	8	5	4	0
SOR	B/W		Quad		Opcode		SRC-Dest		RAM Address

SONR	B/W		Quad		Opcode		SRC	Dest
------	-----	--	------	--	--------	--	-----	------

SINGLE OPERAND INSTRUCTION

	15	14	13	12	9	8	5	4	0					
Instruction ¹	B/W ²	Quad ³	Opcode				R/S ⁴ Dest ⁴		RAM Address					
SOR	0 = B 1 = W	10	1100	MOVE	SRC	.Dest	0000	SORA	RAM	ACC	00000	R00	RAM Reg 00	
			1101	COMP	SRC	..Dest	0010	SORY	RAM	Y Bus
			1110	INC	SRC + 1	..Dest	0011	SORS	RAM	Status	11111	R31	RAM Reg 31	
			1111	NEG	SRC + 1	..Dest	0100	SOAR	ACC	RAM				
							0110	SODR	D	RAM				
				0111	SOIR	I	RAM							
				1000	SOZR	0	RAM							
				1001	SOZER	D(0E)	RAM							
				1010	SOSER	D(SE)	RAM							
				1011	SORR	RAM	RAM							
Instruction	B/W	Quad	Opcode				R/S ⁴		Destination					
SONR	0 = B 1 = W	11	1100	MOVE	SRC	..Dest	0100	SOA	ACC	00000	NRY	Y Bus		
			1101	COMP	SRC	..Dest	0110	SOD	D	00001	NRA	ACC		
			1110	INC	SRC + 1	..Dest	0111	SOI	I	00100	NRS	Status ⁵		
			1111	NEG	SRC + 1	..Dest	1000	SOZ	0	00101	NRAS	ACC, Status ⁵		
							1001	SOZE	D(0E)					
				1010	SOSE	D(SE)								

Notes: 1. The instruction mnemonic designates different instruction formats used in the Am29117. They are useful in assembly microcode with the System 29 AMDASM™ meta assembler.
 2. B = Byte Mode, W = Word Mode.
 3. See Instruction Set description.
 4. R = Source; S = Source; Dest = Destination.
 5. When status is destination,
 Status i .. Yi i = 0 to 3 (Byte mode)
 i = 0 to 7 (Word mode)

Y BUS AND STATUS - SINGLE OPERAND INSTRUCTIONS

Instruction	Opcode	Description	B/W	Y - Bus	Flag3	Flag2	Flag1	LINK	OVR	N	C	Z
SOR	MOVE	SRC .Dest	0 = B	Y .. SRC	NC	NC	NC	NC	0	U	0	U
SONR	COMP	SRC ..Dest	1 = W	Y .. SRC	NC	NC	NC	NC	0	U	0	U
	INC	SRC + 1 .. Dest		Y .. SRC + 1	NC	NC	NC	NC	U	U	U	U
	NEG	SRC + 1 ..Dest		Y .. SRC + 1	NC	NC	NC	NC	U	U	U	U

SRC = Source
 U = Update
 NC = No Change

0 = Reset
 1 = Set
 i = 0 to 15 when not specified

AMDASM is a registered trademark of Advanced Micro Devices, Inc.

Two Operand Instructions

The Two Operand Instructions contain five indicators: byte or word mode, opcode, R source, S source, and destination. They are further subdivided into two types. The first type uses RAM as the source and/or destination and the second type does not use RAM as source or destination. The first type has two formats; the only difference is in the quadrant. Under the control of instruction inputs, the desired function is performed on the specified sources and the result is stored in the

specified destination or placed on the Y-bus or both. The least significant four bits of the status register (OVR, N, C, Z) are affected by the arithmetic functions performed and only the N and Z bits are affected by the logical functions performed. The OVR and C bits of the status register are forced to ZERO for logical functions. Add with carry and Subtract with carry instructions are useful for Multiprecision Add or Subtract.

TWO OPERAND FIELD DEFINITIONS

	15	14	13	12	9	8	5	4	0	
TOR1	B/W		Quad		SRC-SRC -Dest		Opcode		RAM Address	
TOR2	B/W		Quad		SRC-SRC -Dest		Opcode		RAM Address	
TONR	B/W		Quad		SRC-SRC		Opcode		Dest	

TWO OPERAND INSTRUCTIONS

Instruction	B/W	Quad	R ¹	S ¹	Dest ¹	Opcode	RAM Address					
TOR1	0 = B 1 = W	00	0000	TORAA	RAM	ACC	0000	SUBR	S minus R	00000	R00	RAM Reg 00
			0010	TORIA	RAM	I	ACC	0001	SUBRC ²	S minus R with carry	11111	R31
	0011	TODRA	D	RAM	ACC	0010	SUBS	R minus S				
	1000	TORAY	RAM	ACC	Y Bus	0011	SUBSC ²	R minus S with carry				
	1010	TORIY	RAM	I	Y Bus	0100	ADD	R plus S				
	1011	TODRY	D	RAM	Y Bus	0101	ADDC	R plus S with carry				
	1100	TORAR	RAM	ACC	RAM	0110	AND	R • S				
	1110	TORIR	RAM	I	RAM	0111	NAND	R • S				
	1111	TODRR	D	RAM	RAM	1000	EXOR	R ⊕ S				
						1001	NOR	R + S				
						1010	OR	R + S				
						1011	EXNOR	R ⊕ S				

Instruction	B/W	Quad	R ¹	S ¹	Dest ¹	Opcode	RAM Address						
TOR2	0 = B 1 = W	10	0001	TODAR	D	ACC	0000	SUBR	S minus R	00000	R00	RAM Reg 00	
			0010	TOAIR	ACC	I	RAM	0001	SUBRC ²	S minus R with carry	11111	R31	RAM Reg 31
			0101	TODIR	D	I	RAM	0010	SUBS	R minus S			
								0011	SUBSC ²	R minus S with carry			
					0100	ADD	R plus S						
					0101	ADDC	R plus S with carry						
					0110	AND	R • S						
					0111	NAND	R • S						
					1000	EXOR	R ⊕ S						
					1001	NOR	R + S						
					1010	OR	R + S						
					1011	EXNOR	R ⊕ S						

- Notes: 1. R = Source
S = Source
Dest = Destination
2. During subtraction the carry is interpreted as borrow.

TWO OPERAND INSTRUCTIONS

Instruction	B/W	Quad	R ¹	S ¹	Opcode	Destination						
TONR	0 = B	11	0001	TODA	D	ACC	0000	SUBR	S minus R	00000	NRY	Y Bus
	1 = W		0010	TOAI	ACC	I	0001	SUBRC ³	S minus R with carry	00001	NRA	ACC
			0101	TODI	D	I	0010	SUBS	R minus S	00100	NRS	Status ²
			0011	SUBSC ³	R minus S with carry	00101	NRAS	ACC, Status ²				
			0100	ADD	R plus S							
			0101	ADDC	R plus S with carry							
			0110	AND	R·S							
			0111	NAND	R·S							
			1000	EXOR	R⊕S							
			1001	NOR	R+S							
			1010	OR	R+S							
			1011	EXNOR	R⊕S							

- Notes: 1. R = Source
 S = Source
 2. When status is destination,
 Status i. Y_i i = 0 to 3 (Byte mode)
 i = 0 to 7 (Word mode)
 3. During subtraction the carry is interpreted as borrow.

Y BUS AND STATUS CONTENTS - TWO OPERAND INSTRUCTIONS

Instruction	Opcode	Description	B/W	Y - Bus	Flag3	Flag2	Flag 1	LINK	OVR	N	C	Z
TOR1 TOR2 TONR	SUBR	S minus R	0 = B	$Y_{i-1} - S + \bar{R} + 1$	NC	NC	NC	NC	U	U	U	U
	SUBRC	S minus R with carry	1 = w	$Y_{i-1} - S + \bar{R} + QC$	NC	NC	NC	NC	U	U	U	U
	SUBS	R minus S		$Y_{i-1} - R + \bar{S} + 1$	NC	NC	NC	NC	U	U	U	U
	SUBSC	R minus S with carry		$Y_{i-1} - R + \bar{S} + QC$	NC	NC	NC	NC	U	U	U	U
	ADD	R plus S		$Y_{i-1} - R + S$	NC	NC	NC	NC	U	U	U	U
	ADDC	R plus S with carry		$Y_{i-1} - R + S + QC$	NC	NC	NC	NC	U	U	U	U
	AND	R·S		$Y_{i-1} - R_i \text{ AND } S_i$	NC	NC	NC	NC	0	U	0	U
	NAND	$\overline{R \cdot S}$		$Y_{i-1} - R_i \text{ NAND } S_i$	NC	NC	NC	NC	0	U	0	U
	EXOR	R⊕S		$Y_{i-1} - R_i \text{ EXOR } S_i$	NC	NC	NC	NC	0	U	0	U
	NOR	$\overline{R + S}$		$Y_{i-1} - R_i \text{ NOR } S_i$	NC	NC	NC	NC	0	U	0	U
	OR	R + S		$Y_{i-1} - R_i \text{ OR } S_i$	NC	NC	NC	NC	0	U	0	U
	EXNOR	$\overline{R \oplus S}$		$Y_{i-1} - R_i \text{ EXNOR } S_i$	NC	NC	NC	NC	0	0	0	U

- U = Update
 NC = No Change
 0 = Reset
 1 = Set
 i = 0 to 15 when not specified

Single Bit Shift Instructions

The Single Bit Shift Instructions contain four indicators: byte or word mode, direction and shift linkage, source and destination. They are further subdivided into two types. The first type uses RAM as the source and/or destination and the second type does not use RAM as source or destination. Under the control of the instruction inputs, the desired shift function is performed on the specified source and the result is stored in the specified destination or placed on the Y-bus or both. The direction and shift linkage indicator defines the direction of the shift (up or down) as well as what will be shifted into the vacant bit. On a shift-up instruction, the LSB may be loaded with ZERO, ONE,

or the Link-Status bit (QLINK). The MSB is loaded into the Link-Status bit as shown in Figure 2. On a shift-down instruction, the MSB may be loaded with ZERO, ONE, the contents of the Status Carry flip-flop, (QC), the Exclusive-OR of the Negative-Status bit and the Overflow-Status bit (QN \oplus QOVR) or the Link-Status bit. The LSB is loaded into the Link-Status bit as shown in Figure 3. The N and Z bits of the Status register are affected but the OVR and C bits are forced to ZERO. The Shift-Down with QN \oplus QOVR is useful for Two's Complement multiplication.

SINGLE BIT SHIFT FIELD DEFINITIONS:

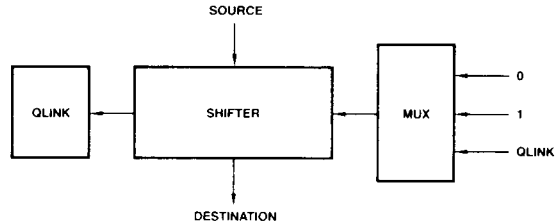
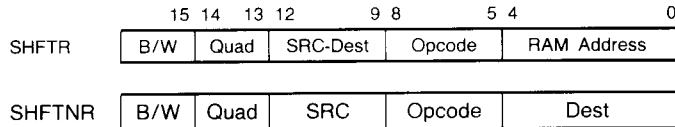

PF000360

Figure 2. Shift Up Function

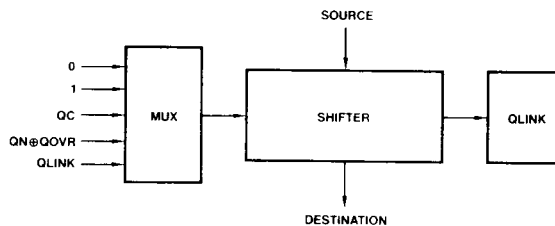

PF000350

Figure 3. Shift Down Function

SINGLE BIT SHIFT INSTRUCTIONS

SINGLE BIT SHIFT

Instruction	B/W	Quad	U ¹			Opcode				RAM Address			
SHFTR	0 = B	10	0110	SHRR	RAM	RAM	0000	SHUPZ	Up	0	00000	R00	RAM Reg 00
	1 = W		0111	SHDR	D	RAM	0001	SHUP1	Up	1
							0010	SHUPL	Up	QLINK	11111	R31	RAM Reg 31
							0100	SHDNZ	Down	0			
							0101	SHDN1	Down	1			
							0110	SHDNL	Down	QLINK			
							0111	SHDNC	Down	QC			
						1000	SHDNOV	Down	QN⊕QOVR				

Instruction	B/W	Quad	U ¹			Opcode				Destination			
SHFTNR	0 = B	11	0110	SHA	ACC	0000	SHUPZ	Up	0	00000	NRY	Y Bus	
	1 = W		0111	SHD	D	0001	SHUP1	Up	1	00001	NRA	ACC	
							0010	SHUPL	Up	QLINK			
							0100	SHDNZ	Down	0			
							0101	SHDN1	Down	1			
							0110	SHDNL	Down	QLINK			
							0111	SHDNC	Down	QC			
						1000	SHDNOV	Down	QN⊕QOVR				

Note 1. U = Source
Dest = Destination

Y BUS AND STATUS - SINGLE BIT SHIFT INSTRUCTIONS

Instruction	Opcode	Description	B/W	Y - Bus	Flag3	Flag2	Flag1	LINK	OVR	N	C	Z
SHR SHNR	SHUPZ SHUP1 SHUPL	Up 0 Up 1 Up QLINK	1 = W	Y _i - SRC _{i-1} , i = 1 to 15; Y ₀ - Shift Input	NC	NC	NC	SRC ₁₅ *	0	SRC ₁₄	0	U
			0 = B	Y _i - SRC _{i-1} , i = 1 to 7; Y ₀ - Shift Input; Y ₈ - SRC ₇ , Y _i - SRC _{i-8} for i = 9 to 15	NC	NC	NC	SRC ₇ *	0	SRC ₆	0	U
	SHDNZ SHDN1 SHDNL SHDNC SHCNOV	Down 0 Down 1 Down QLINK Down QC Down QN⊕QOVR	1 = W	Y _i - SRC _{i+1} , i = 0 to 14; Y ₁₅ - Shift Input	NC	NC	NC	SRC ₀ *	0	Shift Input	0	U
			0 = B	Y _i - SRC _{i+1} , i = 0 to 6; Y _i - SRC _{i-7} , i = 8 to 14; Y _{7,15} - Shift Input	NC	NC	NC	SRC ₀ *	0	Shift Input	0	U

SRC = Source
U = Update
NC = No Change
0 = Reset
1 = Set
i = 0 to 15 when not specified

*Shifted Output is loaded into the QLINK.

Bit Oriented Instructions

The Bit Oriented Instructions contain four indicators: byte or word mode, operation, source/destination, and the bit position of the bit to be operated on (Bit 0 is the least significant bit). They are further subdivided into two types. The first type uses the RAM as both source and destination and has two kinds of formats which differ only by quadrant. The second type does not use the RAM as a source or a destination. Under the control of the instruction inputs, the desired function is performed on the specified source and the result is stored in the specified destination or placed on the Y-bus or both. The operations which can be performed are: Set Bit n which forces the n^{th} bit to a ONE leaving other bits unchanged; Reset Bit n

which forces the n^{th} bit to ZERO leaving the other bits unchanged; Test Bit n , which sets the ZERO Status Bit depending on the state of bit n leaving all the bits unchanged; Load 2^n , which loads ONE in Bit position n and ZERO in all other bit positions; Load $\bar{2}^n$ which loads ZERO in bit position n and ONE in all other bit positions; increment by 2^n , which adds 2^n to the operand; and decrement by 2^n which subtracts 2^n from the operand. For all the Load, Set, Reset and Test instructions, the N and Z bits are affected and OVR and C bit of the Status register are forced to ZERO. For all arithmetic instructions the LSH (OVR, C, N, Z bits) of the Status register is affected.

BIT ORIENTED FIELD DEFINITIONS

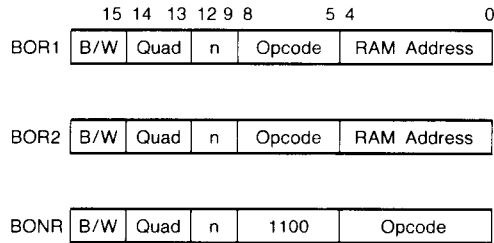

BIT ORIENTED INSTRUCTIONS

Instruction	B/W	Quad	n	Opcode			RAM Address			
BOR1	0 = B 1 = W	11	0 to 15	1101	SETNR	Set RAM, bit n	00000	R00	RAM Reg 00	
				1110	RSTNR	Reset RAM, bit n	
				1111	TSTNR	Test RAM, bit n	11111	R31	RAM Reg 31	
Instruction	B/W	Quad	n	Opcode			RAM Address			
BOR2	0 = B 1 = W	10	0 to 15	1100	LD2NR	2^n ..RAM	00000	R00	RAM Reg 00	
				1101	LDC2NR	$\bar{2}^n$..RAM	
				1110	A2NR	RAM plus 2^n ..RAM	11111	R31	RAM Reg 31	
				1111	S2NR	RAM minus 2^n ..RAM				
Instruction	B/W	Quad	n	Opcode						
BONR	0 = B 1 = W	11	0 to 15	1100	00000	TSTNA		Test ACC, bit n		
					00001	RSTNA		Reset ACC, bit n		
					00010	SETNA		Set ACC, bit n		
					00100	A2NA		ACC plus 2^n ..ACC		
					00101	S2NA		ACC minus 2^n ..ACC		
					00110	LD2NA		2^n ..ACC		
					00111	LDC2NA		$\bar{2}^n$..ACC		
					10000	TSTND		Test D, bit n		
					10001	RSTND		Reset D, bit n		
					10010	SETND		Set D, bit n		
					10100	A2NDY		D plus 2^n .. Y BUS		
					10101	S2NDY		D minus 2^n .. Y Bus		
					10110	LS2NY		2^n .. Y Bus		
10111	LDC2NY		$\bar{2}^n$.. Y Bus							

BIT ORIENTED INSTRUCTIONS
Y BUS AND STATUS - BIT ORIENTED INSTRUCTIONS

Instruction	Opcode	Description	B/W	Y - Bus	Flag3	Flag2	Flag1	LINK	OVR	N	C	Z
BOR1	SETNR	Set RAM Bit n	0 = B	$Y_i - RAM_i$ for $i \neq n$; $Y_n - 1$	NC	NC	NC	NC	0	U	0	0
	RSTNR	Reset RAM, Bit n	1 = W	$Y_i - RAM_i$ for $i \neq n$; $Y_n - 0$	NC	NC	NC	NC	0	U	0	U
	TSTNR	Test Ram, Bit n		$Y_i - 0$ for $i \neq n$; $Y_n - SRC_n$	NC	NC	NC	NC	0	U	0	U
BOR2	LD2NR	$2^n - RAM$		$Y_i - 0$ for $i \neq n$; $Y_n - 1$	NC	NC	NC	NC	0	U	0	0
	LDC2NR	$2^n - RAM$		$Y_i - 1$ for $i \neq n$; $Y_n - 0$	NC	NC	NC	NC	0	U	0	0
	A2NR	$RAM + 2^n - RAM$		$Y_i - RAM + 2^n$	NC	NC	NC	NC	U	U	U	U
	S2NR	$RAM - 2^n - RAM$		$Y_i - RAM - 2^n$	NC	NC	NC	NC	U	U	U	U
BONR	TSTNA	Test ACC, Bit n		$Y_i - 0$ for $i \neq n$; $Y_n - ACC_n$	NC	NC	NC	NC	0	U	0	U
	RSTNA	Reset ACC, Bit n		$Y_i - ACC_i$ for $i \neq n$; $Y_n - 0$	NC	NC	NC	NC	0	U	0	U
	SETNA	Set ACC, Bit n		$Y_i - ACC_i$ for $i \neq n$; $Y_n - 1$	NC	NC	NC	NC	0	U	0	0
	A2NA	$ACC + 2^n - ACC$		$Y_i - ACC + 2^n$	NC	NC	NC	NC	U	U	U	U
	S2NA	$ACC - 2^n - ACC$		$Y_i - ACC - 2^n$	NC	NC	NC	NC	U	U	U	U
	LD2NA	$2^n - ACC$		$Y_i - 0$ for $i \neq n$; $Y_n - 1$	NC	NC	NC	NC	0	U	0	0
	LDC2NA	$2^n - ACC$		$Y_i - 1$ for $i \neq n$; $Y_n - 0$	NC	NC	NC	NC	0	U	0	0
	TSTND	Test D, Bit n		$Y_i - 0$ for $i \neq n$; $Y_n - D_n$	NC	NC	NC	NC	0	U	0	U
	RSTND	Reset D, Bit n*		$Y_i - D_i$ for $i \neq n$; $Y_n - 0$	NC	NC	NC	NC	0	U	0	U
	SETND	Set D, Bit n*		$Y_i - D_i$ for $i \neq n$; $Y_n - 1$	NC	NC	NC	NC	0	U	0	0
	A2NDY	$D + 2^n - Y$ Bus		$Y - D + 2^n$	NC	NC	NC	NC	U	U	U	U
	S2NDY	$D - 2^n - Y$ Bus		$Y - D - 2^n$	NC	NC	NC	NC	U	U	U	U
	LD2NY	$2^n - Y$ Bus		$Y_i - 0$ for $i \neq n$; $Y_n - 1$	NC	NC	NC	NC	0	U	0	0
	LDC2NY	$2^n - Y$ Bus		$Y_i - 1$ for $i \neq n$; $Y_n - 0$	NC	NC	NC	NC	0	U	0	0

SRC = Source
 U = Update
 NC = No Change
 0 = Reset
 1 = Set
 i = 0 to 15 when not specified

*Destination is not D Latch but Y Bus.

Rotate by n Bits Instructions

The Rotate by n Bits Instructions contain four indicators: byte or word mode, source, destination and the number of places the source is to be rotated. They are further subdivided into two types. The first type uses RAM as a source and/or a destination and the second type does not use RAM as a source or destination. The first type has two different formats and the only difference is in the quadrant. The second type has only one format as shown in the table. Under the control of instruction inputs, the n indicator specifies the number of bit positions the source is to be rotated up (0 to 15), and the result

is either stored in the specified destination or placed on the Y-bus or both. An example of this instruction is given in Figure 4. In the Word mode, all 16 bits are rotated up while in the Byte mode, only lower 8 bits (0-7) are rotated up. In the Word mode, a rotate up by n bits is equivalent to a rotate down by (16-n) bits. Similarly, in the Byte mode a rotate up by n bits is equivalent to a rotate down by (8-n) bits. The N and Z bits of the Status Register are affected and OVR and C bits are forced to ZERO.

EXAMPLE: n = 4, Word Mode

Source	0001	0011	0111	1111
Destination	0011	0111	1111	0001

EXAMPLE: n = 4, Byte Mode

Source	0001	0011	0111	1111
Destination	0001	0011	1111	0111

ROTATE BY n BITS FIELD DEFINITIONS

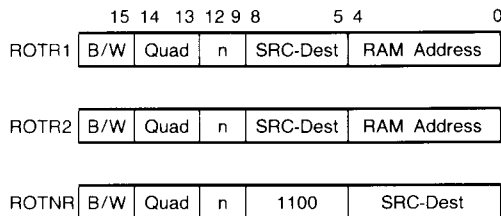

Figure 4. Rotate by n Example

ROTATE BY n BITS INSTRUCTIONS

Instruction	B/W	Quad	n	U ¹			Dest ¹		RAM Address			
ROTR1	0 = B 1 = W	00	0 to 15	1100 1110 1111	RTRA RTRY RTRR	RAM RAM RAM	ACC Y Bus RAM	00000 . . 11111	R00 . . R31	RAM Reg 00 . . RAM Reg 31		
ROTR2	0 = B 1 = W	01	0 to 15	0000 0001	RTAR RTDR	ACC D	RAM RAM	00000 . . 11111	R00 . . R31	RAM Reg 00 . . RAM Reg 31		
Instruction	B/W	Quad	n	U ¹			Dest ¹		RAM Address			
ROTNR	0 = B 1 = W	11	0 to 15	1100					11000 11001 11100 11101	RTDY RTDA RTAY RTAA	D D ACC ACC	Y Bus ACC Y Bus ACC

Note: 1. U = Source
Dest = Destination

Y BUS AND STATUS - ROTATE BY n BITS INSTRUCTIONS

Instruction	Op-code	B/W	Y - Bus	Flag3	Flag2	Flag1	LINK	OVR	N	C	Z
ROTR1 ROTR2 ROTNR		1 = W 0 = B	$Y_i - SRC_{(i-n) \bmod 16}$ $Y_i - SRC_i + 8 = SRC_{(i-n) \bmod 8}$ for $i = 0$ to 7	NC	NC	NC	NC	0	SRC_{15-n} SRC_{8-n}	0	U

SRC = Source
U = No Change
0 = Reset
1 = Set
i = 0 to 15 when not specified

Rotate and Merge Instruction

The Rotate and Merge Instructions contain five indicators: byte or word mode, rotated source, non-rotated source/destination, mask and the number of bit positions a source is to be rotated. The function performed by the Rotate and Merge instruction is illustrated in Figure 5. The rotated source, U, is rotated up by the Barrel Shifter n places. The mask input then selects, on a bit by bit basis, the rotated U input or R

input. A ZERO in bit i of the mask will select the i^{th} bit of the R input as the i^{th} output bit, while ONE in bit i will select the i^{th} rotated U input as the output bit. The output word is stored in the non-rotated operand location. The N and Z bits are affected. The OVR and C bits of the Status register are forced to ZERO. An example of this instruction is given in Figure 6.

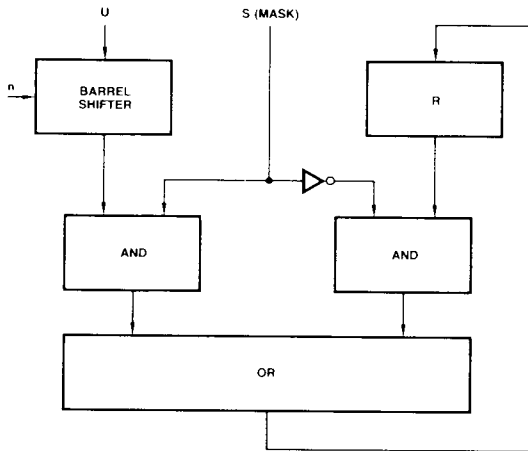

PF000630

Figure 5. Rotate and Merge Function

ROTATE AND MERGE FIELD DEFINITIONS:

	15	14	13	12	9	8	5	4	0
ROTM	B/W		Quad	n	ROT SRC- Non ROT SRC- Mask			RAM Address	

EXAMPLE: n = 4, Word Mode

U	0011	0001	0101	0110
Rotated U	0001	0101	0110	0011
R	1010	1010	1010	1010
Mask (S)	0000	1111	0000	1111
Destination	1010	0101	1010	0011

Figure 6. Rotate and Merge Example

ROTATE AND MERGE INSTRUCTION

Instruction	B/W	Quad	n	U ¹			R/Dest ¹ S ¹			RAM Address			
ROTM	0 = B 1 = W	01	0 to 15	0111	MDAI	D	ACC		00000	R00	RAM Reg 00
				1000	MDAR	D	ACC	RAM					
				1001	MDRI	D	RAM						
				1010	MDRA	D	RAM	ACC					
				1100	MARI	ACC	RAM						
1110	MRAI	RAM	ACC		11111	R31	RAM Reg 31						

U = Rotated Source
R/Dest = Non-Rotated Source and Destination
S = Mask

Y BUS AND STATUS - ROTATE AND MERGE INSTRUCTIONS

Instruction	Opcode	B/W	Y - Bus	Flag3	Flag2	Flag1	LINK	OVR	N	C	Z
ROTM		1=W	$Y_i - (\text{Non Rot Op})_i : (\text{mask})_i + (\text{Rot Op})_{(i-n) \bmod 16} : (\text{mask})_i$	NC	NC	NC	NC	0	U	0	U
		0=B	$Y_i - (\text{Non Rot Op})_i : (\text{mask})_i + (\text{Rot Op})_{(i-n) \bmod 8} : (\text{mask})_i$	NC	NC	NC	NC	0	U	0	U

U = Update
NC = No Change
0 = Reset
1 = Set
i = 0 to 15 when not specified

Rotate and Compare Instructions

The Rotate and Compare Instructions contain five indicators: byte or word mode, rotated source, non-rotated source, mask, and the number of bit positions the rotated source is to be rotated up. Under the control of instruction inputs, the function performed by the Rotate and Compare instruction is illustrated in Figure 7. The rotated operand is rotated by the Barrel Shifter in places. The mask is inverted and ANDed on a bit-by-bit basis

with the output of the Barrel Shifter and R input. Thus, a ONE in the mask input eliminates that bit from the comparison. A ZERO allows the comparison. If the comparison passes, the Zero flag is set. If it fails, the Zero flag is reset. The N and Z bit are affected. The OVR and C bits of the Status register are forced to ZERO. An example of this instruction is given in Figure 8.

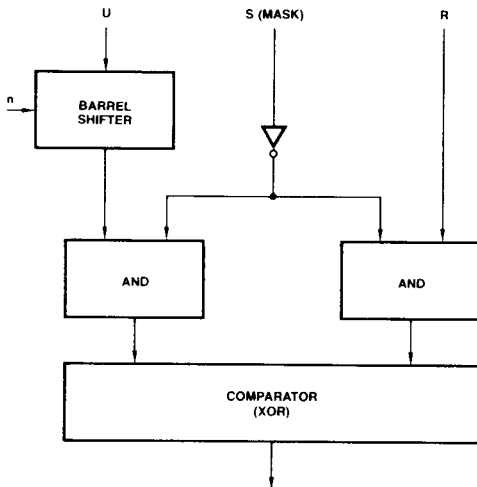

PF000650

Figure 7. Rotate and Compare Function

ROTATE AND COMPARE FIELD DEFINITIONS

	15	14	13	12	9	8	5	4	0
ROTC	B/W		Quad	n	Rot Src- Non Rot Src- Mask		RAM Address		

EXAMPLE: n = 4, Word Mode

U	0011	0001	0101	0110
U Rotated	0001	0101	0110	0011
R	0001	0101	1111	0000
Mask (S)	0000	0000	1111	1111
Z (status) =	1			

Figure 8. Rotate and Compare Examples

ROTATE AND COMPARE INSTRUCTIONS

Instruction	B/W	Quad	n	U ¹ R ¹ S ¹			RAM Address				
ROTC	0 = B 1 = W	01	0 to 15	0010	CDAI	D	ACC		00000	R00	RAM Reg 00
				0011	CDRI	D	RAM	
				0100	CDRA	D	RAM	ACC	11111	R31	RAM Reg 31
				0101	CRAI	RAM	ACC				

U = Rotated Source
R = Non-Rotated Source
S = Mask

Y BUS AND STATUS - ROTATE AND COMPARE INSTRUCTIONS

Instruction	Opcode	B/W	Y - Bus	Flag3	Flag2	Flag1	LINK	OVR	N	C	Z
ROTC		1 = W	$Y_i - (\text{Non Rot Op})_i \cdot (\overline{\text{mask}})_i \oplus (\text{Rot Op})_{(i-n) \bmod 16} \cdot (\text{mask})_i$	NC	NC	NC	NC	0	U	0	U
		0 = B	$Y_i - (\text{Non Rot Op})_i \cdot (\overline{\text{mask}})_i \oplus (\text{Rot Op})_{(i-n) \bmod 8} \cdot (\text{mask})_i$	NC	NC	NC	NC	0	U	0	U

U = Update
NC = No Change
0 = Reset
1 = Set
i = 0 to 15 when not specified

Prioritize Instruction

The Prioritize Instructions contain four indicators: byte or word mode, operand source (R), mask source (S) and destination. They are further subdivided into two types. The function performed by the Prioritize instruction is shown in Figure 9. The R operand is ANDed with the complement of the Mask operand. A ZERO in the Mask operand allows the corresponding bit in the R operand to participate in the priority encoding function. A ONE in the Mask operand forces the corresponding bit in the R operand to a ZERO, eliminating it from participation in the priority encoding function.

The priority encoder accepts a 16-bit input and produces a 5-bit binary-weighted code indicating the bit position of the highest priority active bit. If none of the inputs are active, the output is ZERO. In the Word mode, if input bit 15 is active, the output is 1, etc. Figure 10 lists the output as a function of the highest-priority active-bit position in both the Word and Byte mode. The N and Z bits are affected and the OVR and C bits of the status register are forced to ZERO. The only limitation in this instruction is that the operand and the mask must be from different sources.

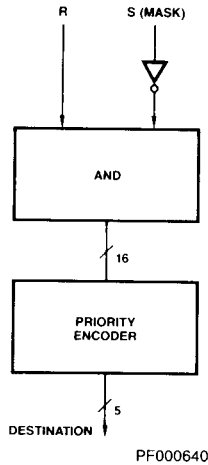

Figure 9. Prioritize Function

PRIORITIZE FIELD DEFINITIONS

		15	14	13	12			9	8			5	4			0
B/W	Quad	Destination				Source (R)				RAM Address/ Mask (S)						
B/W	Quad	Mask (S)				Destination				RAM Address/ Source (R)						
B/W	Quad	Mask (S)				Source (R)				RAM Address/ Destination						
B/W	Quad	Mask (S)				Source (R)				Destination						

WORD MODE

BYTE MODE*

Highest Priority Active Bit	Encoder Output	Highest Priority Active Bit	Encoder Output
None	0	None	0
15	1	7	1
14	2	6	2
.	.	.	.
.	.	.	.
1	15	1	7
0	16	0	8

*Bits 8 through 15 do not participate

Figure 10.

PRIORITIZE INSTRUCTION

Instruction	B/W	Quad	Destination			Source (R)			RAM Address/Mask (S)		
PRT1	0 = B 1 = W	10	1000	PRIA	ACC	0111	RPT1A	ACC	00000	R00	RAM Reg 00
			1010	PR1Y	Y Bus	1001	PR1D	D
			1011	PR1R	RAM			11111	R31	RAM Reg 31	
Instruction	B/W	Quad	Mask (S)			Destination			RAM Address/Source (R)		
PRT2	0 = B 1 = W	10	1000	PRA	Acc	0000	PR2A	ACC	00000	R00	RAM Reg 00
			1010	PRZ	0	0010	PR2Y	Y Bus
			1011	PRI	I			11111	R31	RAM Reg 31	
Instruction	B/W	Quad	Mask (S)			Source (R)			RAM Address/Dest		
PRT3	0 = B 1 = W	10	1000	PRA	ACC	0011	PR3R	RAM	00000	R00	RAM Reg 00
			1010	PRZ	0	0100	PR3A	ACC
			1011	PRI	I	0110	PR3D	D	11111	R31	RAM Reg 31
Instruction	B/W	Quad	Mask (S)			Source (R)			Destination		
PRTNR	0 = B 1 = W	11	1000	PRA	ACC	0100	PRTA	ACC	00000	NRY	Y Bus
			1010	PRZ	0	0110	PRTD	D	00001	NRA	ACC
			1011	PRI	I						

Y BUS AND STATUS - PRIORITIZE INSTRUCTIONS

Instruction	Opcode	B/W	Y - Bus	Flag3	Flag2	Flag1	LINK	OVR	N	C	Z
PRT1 PRT2		1 = W	Y_i - CODE (SCR_n - $mask_n$); Y_m . 0; $i = 0$ to 4 and $n = 0$ to 15 $m = 5$ to 15	NC	NC	NC	NC	0	U	0	U
PRT3 PRTNR		0 = B	Y_i - CODE (SCR_n - $mask_n$); Y_m . 0; $i = 0$ to 3 and $n = 0$ to 7 $m = 4$ to 15	NC	NC	NC	NC	0	U	0	U

SRC = Source NC = No Change 1 = Set
 U = Update 0 = Reset i = 0 to 15 when not specified

Cyclic-Redundancy-Check Instruction

The Cyclic-Redundancy-Check (CRC) Instructions contain one indicator: address of a RAM register to use as the check sum register. The CRC instruction provides a method for generation of the check bits in a CRC calculation. Two CRC instructions are provided – CRC Forward and CRC Reverse. The reason for providing two instructions is that CRC standards do not specify which data bit is to be transmitted first, the LSB or the MSB, but they do specify which check bit must be transmitted first. Figure 11 illustrates the method used to generate these check bits for the CRC Forward function and

Figure 12 illustrates method used for the CRC Reverse function. The ACC serves as a polynomial mask to define the generating polynomial while the RAM register holds the partial result and eventually the calculated check sum. The LINK-bit is used as the serial input. The serial input combines with the MSB of the check-sum register, according to the polynomial defined by the polynomial mask register. When the last input bit has been processed, the check-sum register contains the CRC check bits. The LINK, N and Z bits are affected and the OVR and C bits of the Status register are forced to ZERO.

CYCLIC-REDUNDANCY-CHECK FIELD DEFINITIONS:

		15	14	13	12	9	8	5	4	0
CRCF	1	Quad	0110	0011	RAM Address					
CRCR	1	Quad	0110	1001	RAM Address					

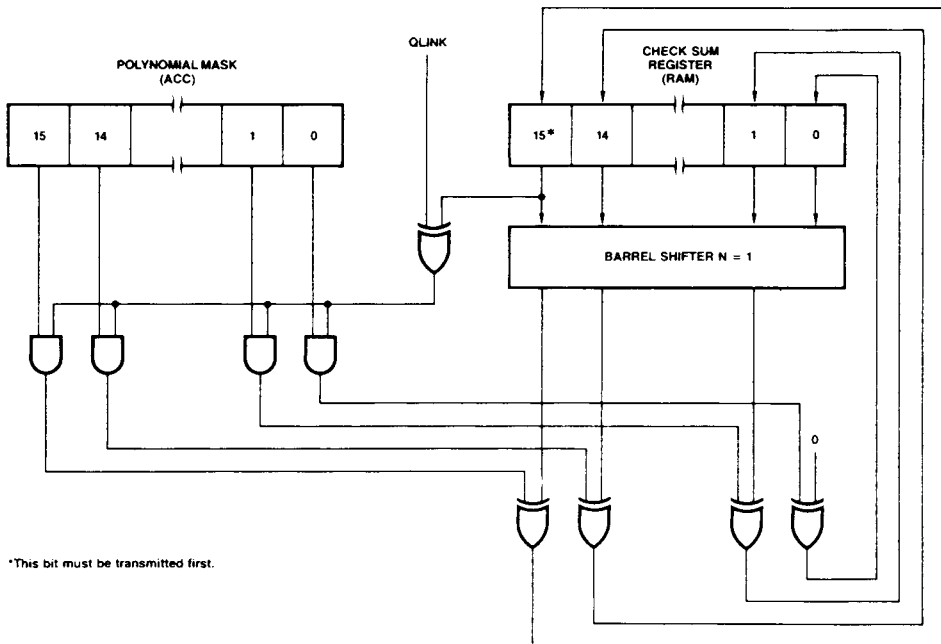

*This bit must be transmitted first.

PF000330

Figure 11. CRC Forward Function

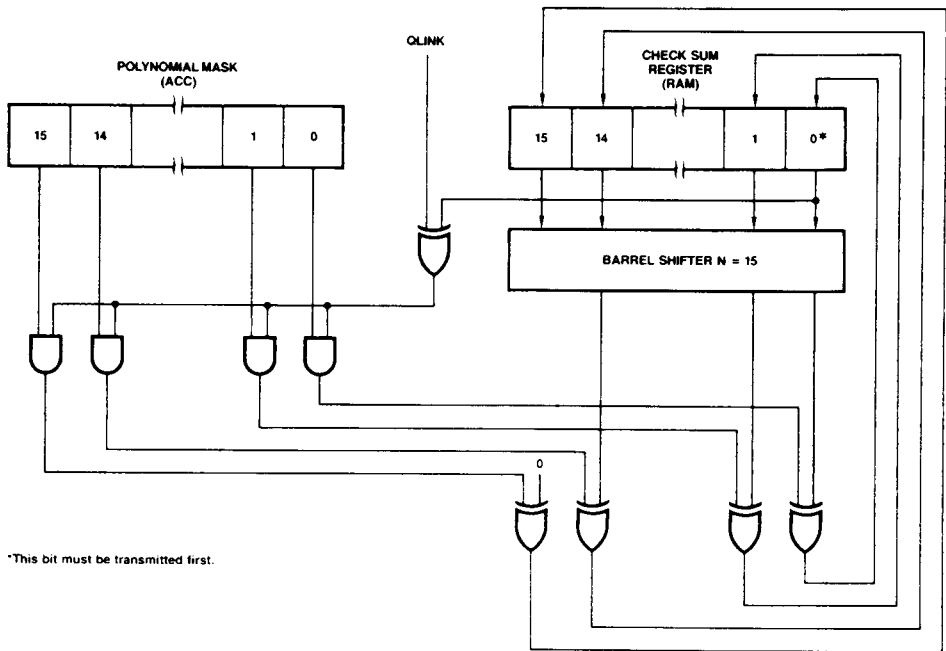

*This bit must be transmitted first.

PF000320

Figure 12. CRC Reverse Function

CYCLIC-REDUNDANCY-CHECK

Instruction	B/W	Quad			RAM Address		
CRCF	1	10	0110	0011	00000	R00	RAM Reg 00
				
					11111	R31	RAM Reg 31
Instruction	B/W	Quad			RAM Address		
CRCR	1	10	0110	1001	00000	R00	RAM Reg 00
				
					11111	R31	RAM Reg 31

Y BUS AND STATUS - CYCLIC-REDUNDANCY-CHECK INSTRUCTION

Instruction	Opcode	B/W	Y - Bus	Flag3	Flag2	Flag1	LINK	OVR	N	C	Z
CRCF		1 = W	$Y_i = [(QLINK \oplus RAM_{15}) \cdot ACC_i]$ $\oplus RAM_{i-1}$ for $i = 15$ to 1 $Y_0 = [(QLINK \oplus RAM_{15}) \cdot ACC_0] \oplus 0$	NC	NC	NC	RAM ₁₅ *	0	U	0	U
CRCR		1 = W	$Y_i = [(QLINK \oplus RAM_0) \cdot ACC_i]$ $\oplus RAM_{i+1}$ for $i = 14$ to 0 $Y_{15} = [(QLINK \oplus RAM_0) \cdot ACC_{15}] \oplus 0$	NC	NC	NC	RAM ₀ *	0	U	0	U

*QLINK is loaded with the shifted out bit from the checksum register.

U = Update
 NC = No Change
 0 = Reset
 1 = Set
 i = 0 to 15 when not specified

Status Instructions

Status Instructions

The Set Status Instruction contains a single indicator. This indicator specifies which bit or group of bits, contained in the status register (Figure 13), are to be set (forced to a ONE).

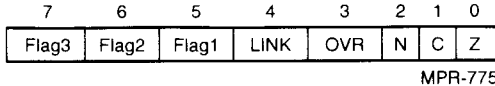

Figure 13. Status Byte

The Reset Status Instruction contains a single indicator. This indicator specifies which bit or group of bits, contained in the status register, are to be reset (forced to ZERO).

The Store Status Instruction contains two indicators; byte/word and a second indicator that specifies the destination of the status register. The Store Status Instruction allows the status of the processor to be saved and restored later, which is an especially useful function for interrupt handling.

The status register is always stored in the lower byte of the RAM or the ACC register. Depending upon byte or word mode the upper byte is unchanged or loaded with all ZEROS respectively.

The Load Status instructions are included in the single operand and two operand instruction types.

The Test Status Instructions contain a single indicator which specifies which one of the 12 possible test conditions are to be placed on the Conditional-Test output. Besides the eight bits in the Status register (QZ, QC, QN, QOVR, QLINK, QFlag1, QFlag 2, and QFlag3), four logical functions ($QN \oplus QOVR$, $(QN \oplus QOVR) + QZ$, $QZ + \overline{QC}$ and LOW may also be selected. These functions are useful in testing results of Two's Complement and unsigned number arithmetic operations. The status register may also be tested via the bidirectional T bus. The code to test the status register via T bus is similar to the code used by instruction lines I_1 to I_4 as shown below. Instruction lines $I_0 - 4$ have priority over T bus for testing the

status register on CT output. See the discussion on the status register for a full description.

T_4 I_4	T_3 I_3	T_2 I_2	T_1 I_1	CT
0	0	0	0	$(N \oplus OVR) + Z$
0	0	0	1	$N \oplus OVR$
0	0	1	0	Z
0	0	1	1	OVR
0	1	0	0	LOW
0	1	0	1	C
0	1	1	0	$Z + \overline{C}$
0	1	1	1	N
1	0	0	0	LINK
1	0	0	1	Flag1
1	0	1	0	Flag2
1	0	1	1	Flag3

STATUS FIELD DEFINITIONS

	15	14	13	12	9	8	5	4	0	
SETST	0	Quad	1011	1010						Opcode
RSTST	0	Quad	1010	1010						Opcode
SVSTR	B/W	Quad	0111	1010						RAM Address/Dest
SVSTNR	B/W	Quad	0111	1010						Destination

STATUS INSTRUCTIONS

Instruction	B/W	Quad			Opcode		
SETST	0	11	1011	1010	00011	SONCZ	Set OVR, N, C, Z
					00101	SL	Set LINK
					00110	SF1	Set Flag1
					01001	SF2	Set Flag2
					01010	SF3	Set Flag3
Instruction	B/W	Quad			Opcode		
RSTST	0	11	1011	1010	00011	RONCZ	Reset OVR, N, C, Z
					00101	RL	Reset LINK
					00110	RF1	Set Flag1
					01001	RF2	Set Flag2
					01010	RF3	Set Flag3
Instruction	B/W	Quad			RAM Address/Dest		
SVSTR	0 = B 1 = W	10	0111	1010	00000	R00	RAM Reg 00
				
					11111	R31	RAM Reg 31
Instruction	B/W	Quad			Destination		
SVSTNR	0 = B 1 = W	11	0111	1010	00000	NRY	Y Bus
					00001	NRA	ACC

STATUS INSTRUCTIONS

Instruction	B/W	Quad			Opcode (CT)		
Test	0	11	1001	1010	00000 00010 00100 00110 01000 01010 01100 01110 10000 10010 10100 10110	TNOZ TNO TZ TOVR TLOW TC TZC TN TL TF1 TF2 TF3	Test (N⊕OVR) + Z Test N⊕OVR Test Z Test OVR Test LOW Test C Test Z + \bar{C} Test N Test LINK Test Flag1 Test Flag2 Test Flag3

Note:

Y BUS AND STATUS - STATUS INSTRUCTIONS

Instruction	Opcode	Description	B/W	Y - Bus	Flag3	Flag2	Flag1	LINK	OVR	N	C	Z	
SETST	SONCZ	Set OVR, N, C, Z	0 = B	$Y_i = 1$ for $i = 0$ to 15	NC	NC	NC	NC	1	1	1	1	
	SL	Set LINK			NC	NC	NC	1	NC	NC	NC	NC	NC
	SF1	Set Flag1			NC	NC	1	NC	NC	NC	NC	NC	NC
	SF2	Set Flag2			NC	1	NC	NC	NC	NC	NC	NC	NC
	SF3	Set Flag3			1	NC	NC	NC	NC	NC	NC	NC	NC
RSTST	RONCZ	Reset OVR, N, C, Z	0 = B	$Y_i = 0$ for $i = 0$ to 15	NC	NC	NC	NC	0	0	0	0	
	RL	Reset LINK			NC	NC	NC	0	NC	NC	NC	NC	
	RF1	Reset Flag1			NC	NC	0	NC	NC	NC	NC	NC	
	RF2	Reset Flag2			NC	0	NC	NC	NC	NC	NC	NC	
	RF3	Reset Flag3			0	NC	NC	NC	NC	NC	NC	NC	
SVSTR SVSTNR		Save Status*	0 = B 1 = W	$Y_i =$ Status for $i = 0$ to 7; $Y_i = 0$ for $i = 8$ to 15	NC	NC	NC	NC	NC	NC	NC		
Test	TNOZ	Test (N⊕OVR) + Z	0 = B	**	NC	NC	NC	NC	NC	NC	NC	NC	
	TNO	Test N⊕OVR			NC	NC	NC	NC	NC	NC	NC	NC	
	TZ	Test Z			NC	NC	NC	NC	NC	NC	NC	NC	
	TOVR	Test OVR			NC	NC	NC	NC	NC	NC	NC	NC	
	TLOW	Test LOW			NC	NC	NC	NC	NC	NC	NC	NC	
	TC	Test C			NC	NC	NC	NC	NC	NC	NC	NC	
	TZC	Test Z + \bar{C}			NC	NC	NC	NC	NC	NC	NC	NC	
	TN	Test N			NC	NC	NC	NC	NC	NC	NC	NC	
	TL	Test LINK			NC	NC	NC	NC	NC	NC	NC	NC	
	TF1	Test Flag1			NC	NC	NC	NC	NC	NC	NC	NC	
	TF2	Test Flag2			NC	NC	NC	NC	NC	NC	NC	NC	
	TF3	Test Flag3			NC	NC	NC	NC	NC	NC	NC	NC	

U = Update
 NC = No Change
 0 = Reset
 1 = Set

$i = 0$ to 15 when not specified

*In byte mode only the lower byte from the Y bus is loaded into the RAM or ACC and in word mode all 16-bits from the Y bus are loaded into the RAM or ACC.

**Y-Bus is Undefined.

NO-OP Instruction

The NO-OP Instruction has a fixed 16-bit code. This instruction does not change any internal registers in the Am291176. It preserves the status register, RAM register and the ACC register.

NO OPERATION FIELD DEFINITION

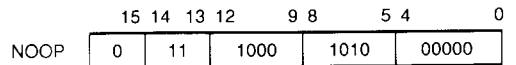

NO-OP INSTRUCTION

Instruction	B/W	Quad			
NOOP	0	11	1000	1010	00000

Y BUS AND STATUS - NO-OP INSTRUCTION

Instruction	Opcode	B/W	Y - Bus	Flag3	Flag2	Flag1	LINK	OVR	N	C	Z
NOOP		0 = B	*	NC	NC	NC	NC	NC	NC	NC	NC

SRC = Source

U = Update

NC = No Change

0 = Reset

1 = Set

i = 0 to 15 when not specified

*Y-Bus is undefined.

SUMMARY OF MNEMONICS

INSTRUCTION TYPE

SOR	Single Operand RAM
SONR	Single Operand Non-RAM
TOR1	Two Operand RAM (Quad 0)
TOR2	Two Operand RAM (Quad 2)
TONR	Two Operand Non-RAM
SHFTR	Single Bit Shift RAM
SHFTNR	Single Bit Shift Non-RAM
ROTR1	Rotate n Bits RAM (Quad 0)
ROTR2	Rotate n Bits RAM (Quad 1)
ROTNR	Rotate n Bits Non-RAM
BOR1	Bit Oriented RAM (Quad 3)
BOR2	Bit Oriented RAM (Quad 2)
BONR	Bit Oriented Non-RAM
ROTM	Rotate and Merge
ROTC	Rotate and Compare
PRT1	Prioritize RAM; Type 1
PRT2	Prioritize RAM; Type 2
PRT3	Prioritize RAM; Type 3
PRTNR	Prioritize Non-RAM
CRCF	Cyclic Redundancy Check Forward
CRCR	Cyclic Redundancy Check Reverse
NOOP	No Operation
SETST	Set Status
RSTST	Reset Status
SVSTR	Save Status RAM
SVSTNR	Save Status Non-RAM
TEST	Test Status

SOURCE AND DESTINATION

Single Operand

SORA	Single Operand RAM to ACC
SORY	Single Operand RAM to Y Bus
SORS	Single Operand RAM to Status
SOAR	Single Operand ACC to RAM
SODR	Single Operand D to RAM
SOIR	Single Operand I to RAM
SOZR	Single Operand 0 to RAM
SOZER	Single Operand D(0E) to RAM
SOSER	Single Operand D(SE) to RAM
SORR	Single Operand RAM to RAM
SOA	Single Operand ACC
SOD	Single Operand D
SOI	Single Operand I
SOZ	Single Operand 0
SOZE	Single Operand D(0E)
SOSE	Single Operand D(SE)
NRY	Non-RAM Y Bus
NRA	Non-RAM ACC
NRS	Non-RAM Status
NRAS	Non-RAM ACC, Status

Two Operand

TORAA	Two Operand RAM, ACC to ACC
TORIA	Two Operand RAM, I to ACC
TODRA	Two Operand D, RAM to ACC
TORAY	Two Operand RAM, ACC to Y Bus
TORIY	Two Operand RAM, I to Y Bus
TODRY	Two Operand D, RAM to Y Bus
TORAR	Two Operand RAM, ACC to RAM
TORIR	Two Operand RAM, I to RAM
TODRR	Two Operand D, RAM to RAM
TODAR	Two Operand D, ACC to RAM
TOAIR	Two Operand ACC, I to RAM
TODIR	Two Operand D, I to RAM
TODA	Two Operand D, ACC
TOAI	Two Operand ACC, I
TODI	Two Operand D, I

Single Bit Shift

SHRR	Shift RAM, Store in RAM
SHDR	Shift D, Store in RAM
SHA	Shift ACC
SHD	Shift D

Rotate n Bits

RTRA	Rotate RAM, Store in ACC
RTRY	Rotate RAM, Place on Y Bus
RTRR	Rotate RAM, Store in RAM
RTAR	Rotate ACC, Store in RAM
RTDR	Rotate D, Store in RAM
RTDY	Rotate D, Place on Y Bus
RTDA	Rotate D, Store in ACC
RTAY	Rotate ACC, Place on Y Bus
RTAA	Rotate ACC, Store in ACC

Rotate and Merge

MDAI	Merge Disjoint Bits of D and ACC Using I as Mask and Store in ACC
MDAR	Merge Disjoint Bits of D and ACC Using RAM as Mask and Store in ACC
MDRI	Merge Disjoint Bits of D and RAM Using I as Mask and Store in RAM
MDRA	Merge Disjoint Bits of D and RAM Using ACC as Mask and Store in RAM
MARI	Merge Disjoint Bits of ACC and RAM Using I as Mask and Store in RAM
MRAI	Merge Disjoint Bits of RAM and ACC Using I as Mask and Store in ACC

Rotate and Compare

CDAI	Compare Unmasked Bits of D and ACC Using I as Mask
------	--

CDRI Compare Unmasked Bits of D and RAM Using I as Mask
 CDRA Compare Unmasked Bits of D and RAM Using ACC as Mask
 CRAI Compare Unmasked Bits of RAM and ACC Using I as Mask

Prioritize

PR1A ACC as Destination for Prioritize Type 1
 PR1Y Y Bus as Destination for Prioritize Type 1
 PR1R RAM as Destination for Prioritize Type 1
 PRT1A ACC as Source for Prioritize Type 1
 PR1D D as Source for Prioritize Type 1
 PR2A ACC as Destination for Prioritize Type 2
 PR2Y Y Bus as Destination for Prioritize Type 2
 PR3R RAM as Source for Prioritize Type 3
 PR3A ACC as Source for Prioritize Type 3
 PR3D D as Source for Prioritize Type 3
 PRTA ACC as source for Prioritize Type Non-RAM
 PRTD D as Source for Prioritize Type Non-RAM
 PRA ACC as Mask for Prioritize Type 2, 3, and Non-RAM
 PRZ Mask Equal to Zero for Prioritize Type 2, 3, and Non-RAM
 PRI I as Mask for Prioritize Type 2, 3, and Non-RAM

OPCODE

Addition

ADD Add without Carry
 ADDC Add with Carry
 A2NA Add 2^n to ACC
 A2NR Add 2^n to RAM
 A2NDY Add 2^n to D, Place on Y Bus

Subtraction

SUBR Subtract R from S without Carry
 SUBRC Subtract R from S with Carry
 SUBS Subtract S from R without Carry
 SUBSC Subtract S from R with Carry
 S2NR Subtract 2^n from RAM
 S2NA Subtract 2^n from ACC
 S2NDY Subtract 2^n from D, Place on Y Bus

Logical Operations

AND Boolean AND
 NAND Boolean NAND
 EXOR Boolean EXOR
 NOR Boolean NOR
 OR Boolean OR
 EXNOR Boolean EXNOR

SHIFTS

SHUPZ Shift Up Towards MSB with 0 Insert
 SHUP1 Shift Up Towards MSB with 1 Insert
 SHUPL Shift Up Towards MSB with LINK Insert

SHDNZ Shift Down Towards LSB with 0 Insert
 SHDN1 Shift Down Towards LSB with 1 Insert
 SHDNL Shift Down Towards LSB with LINK Insert
 SHDNC Shift Down Towards LSB with Carry Insert
 SHDNOV Shift Down Towards LSB with Sign EXOR Overflow Insert

Loads

LD2NR Load 2^n into RAM
 LDC2NR Load 2^n into RAM
 LD2NA Load 2^n into ACC
 LDC2NA Load 2^n into ACC
 LD2NY Place 2^n on Y Bus
 LDC2NY Place 2^n on Y Bus

Bit Oriented

SETNR Set RAM, Bit n
 SETNA Set ACC, Bit n
 SETND Set D, Bit n
 SONGZ Set OVR, N, C, Z, in Status Register
 SL Set LINK Bit in Status Register
 SF1 Set Flag1 Bit in Status Register
 SF2 Set Flag2 Bit in Status Register
 SF3 Set Flag3 Bit in Status Register
 RSTNR Reset RAM, Bit n
 RSTNA Reset ACC, Bit n
 RSTND Reset D, Bit n
 RONCZ Reset OVR, N, C, Z, in Status Register
 RL Reset LINK Bit in Status Register
 RF1 Reset Flag1 Bit in Status Register
 RF2 Reset Flag2 Bit in Status Register
 RF3 Reset Flag3 Bit in Status Register
 TSTNR Test RAM, Bit n
 TSTNA Test ACC, Bit n
 TSTND Test D, Bit n

Arithmetic Operations

MOVE Move and Update Status
 COMP Complement (1's Complement)
 INC Increment
 NEG Two's Complement

Conditional Test

TNOZ Test $(N \oplus OVR) + Z$
 TNO Test $N \oplus OVR$
 TZ Test Zero Bit
 TOVR Test Overflow Bit
 TLOW Test for LOW
 TC Test Carry Bit
 TZC Test $Z + \bar{C}$
 TN Test Negative Bit
 TL Test LINK Bit
 TF1 Test Flag1 Bit
 TF2 Test Flag2 Bit
 TF3 Test Flag3 Bit

ABSOLUTE MAXIMUM RATINGS

Storage Temperature -65 to +150°C
 Case Temperature Under Bias (T_C) -55 to +125°C
 Supply Voltage to Ground Potential -0.5 V to +7.0 V
 DC Voltage Applied to Outputs For
 High Output State -0.5 V to + V_{CC} Max.
 DC Input Voltage -0.5 V to +5.5 V
 DC Output Current, Into Outputs 30 mA
 DC Input Current -30 mA to +5.0 mA

Stresses above those listed under ABSOLUTE MAXIMUM RATINGS may cause permanent device failure. Functionality at or above these limits is not implied. Exposure to absolute maximum ratings for extended periods may affect device reliability.

OPERATING RANGES

Commercial (C) Devices

Temperature (T_A) 0 to +55°C
 Supply Voltage +4.75 V to +5.25 V
 Air Velocity 300 linear feet per minute

Operating ranges define those limits over which the functionality of the device is guaranteed.

DC CHARACTERISTICS over operating range unless otherwise specified

Parameters	Description	Test Conditions (Note 1)		Min.	Max.	Units	
V_{OH}	Output HIGH Voltage	$V_{CC} = \text{Min.}$ $V_{IN} = V_{IH}$ or V_{IL}	Y_{0-15} T_{1-4} CT	$I_{OH} = -1.6$ mA	2.4	Volts	
V_{OL}	Output LOW Voltage	$V_{CC} = \text{Min.}$ $V_{IN} = V_{IH}$ or V_{IL}	Y_{0-15} T_{1-4} CT	$I_{OL} = 16$ mA	0.5	Volts	
V_{IH}	Guaranteed Input Logical HIGH Voltage (Note 5)		All Inputs	2.0		Volts	
V_{IL}	Guaranteed Input Logical LOW Voltage (Note 5)		All Inputs		0.8	Volts	
V_I	Input Clamp Voltage	$V_{CC} = \text{Min.}$	All Inputs	$I_{IN} = -18$ mA	-1.5	Volts	
I_{IL}	Input LOW Current	$V_{CC} = \text{Max.}$ $V_{IN} = 0.5$ Volts (Note 3)	I_{EN} SRE DLE I_{0-4} I_{5-15} OET OEY CP T_{1-4} D $_{0-15}$		-0.50 -0.50 -1.00 -1.00 -0.50 -0.50 -0.50 -1.50 -0.55 -0.50	mA	
I_{IH}	Input HIGH Current	$V_{CC} = \text{Max.}$ $V_{IN} = 2.4$ Volts (Note 3)	I_{EN} SRE DLE I_{0-4} I_{5-15} OET OEY CP T_{1-4} D $_{0-15}$		50 50 100 100 50 50 50 150 100 50	μ A	
I_I	Input HIGH Current	$V_{CC} = \text{Max.}$ $V_{IN} = 5.5$ Volts	All Inputs		1.0	mA	
I_{OZH}	Off State (HIGH Impedance) Output Current	$V_{CC} = \text{Max.}$ $V_O = 2.4$ Volts (Note 3)	T_{1-4} (Note 3) Y_{0-15}		100 50	μ A	
I_{OZL}	Off State (HIGH Impedance) Output Current	$V_{CC} = \text{Max.}$ $V_O = 0.5$ Volts (Note 4)	T_{1-4} (Note 3) Y_{0-15}		-550 -50	μ A	
I_{OS}	Output Short Circuit Current	$V_{CC} = \text{Max.} + 0.5$ Volts $V_O = 0.5$ Volts (Note 2)			-30 -85	mA	
I_{CC}	Power Supply Current (Note 4)	$V_{CC} = \text{Max.}$	COM'L	$T_A = 0$ to 55°C (Note 6) $T_A = 55^\circ\text{C}$		735 535	mA

- Notes: 1. For conditions shown as Min. or Max., use the appropriate value specified under Operating Ranges for the applicable device type.
 2. Not more than one output should be shorted at a time. Duration of the short circuit test should not exceed one second.
 3. Y_{0-15} , T_{1-4} are three-state outputs internally connected to TTL inputs. Input characteristics are measured under conditions such that the outputs are in the OFF state.
 4. Worst case I_{CC} is at minimum temperature.
 5. These input levels provide zero noise immunity and should be tested only in a static, noise-free environment.
 6. Cold start.

SWITCHING CHARACTERISTICS over operating range unless otherwise specified

($T_A = 0$ to $+55^\circ\text{C}$, $V_{CC} = 4.75$ to 5.25 V, $C_L = 50$ pF) (Note 7)

A. Combinational Delays (nsec)

		Outputs		
		Y ₀₋₁₅	T ₁₋₄	CT
	I ₀₋₄ (ADDR)	79	84	-
	I ₀₋₁₅ (DATA)	79	84	-
	I ₀₋₁₅ (INSTR)	79	84	48
Input	DLE	58**	60	-
	T ₁₋₄	-	-	39
	CP	56	62	36
	D ₀₋₁₅	62	64	-
	IEN	-	-	43

B. Enable/Disable Times (nsec)



($C_L = 5\text{pF}$ for disable only)

From Input	To Output	Enable		Disable	
		t _{PZH}	t _{PZL}	t _{PHZ}	t _{PLZ}
$\overline{\text{OE}}_Y$	Y ₀₋₁₅	20	20	20	20
$\overline{\text{OE}}_T$	T ₁₋₄	25	25	25	25

C. Clock and Pulse Requirements (nsec)

Input	Min Low Time	Min High Time
CP	20	30
DLE	-	15
IEN	22	-

D. Setup and Hold Times (nsec)

Input	With Respect to	High-to-Low Transition		Low-to-High Transition		Comment			
		Set-up	Hold	Set-up	Hold				
I ₀₋₄ (RAM ADDR)	CP	(t _{s1}) 24	(t _{h1}) 0	-	-	Single ADDR (Source)			
I ₀₋₄ (RAM ADDR)	CP and IEN both LOW	(t _{s2}) 10	Do Not Change		(t _{h7}) 2	Two ADDR (Destination)			
I ₀₋₁₅ (DATA)	CP	-	-	(t _{s8}) 65	(t _{h8}) 2				
I ₀₋₁₅ (INSTR)	CP	(t _{s3}) 38†	(t _{h3}) † 17	(t _{s9}) 65	(t _{h9}) 2				
I ₀₋₁₅ (INSTR)	IEN 	(t _{s16}) 6	(t _{h16}) 18	-	-	Two ADDR Immediate			
IEN 	CP 	-	-	-	(t _{h15}) 8	Two ADDR Immediate			
IEN HIGH	CP	(t _{s4}) 10	-	-	(t _{h10}) 1	Disable			
IEN LOW	CP	-	(t _{s5}) 20	-	(t _{h5})† 2	(t _{s11}) 22	(t _{h11})†† 1	Enable	Immediate first cycle
SRE	CP	-	-	(t _{s12}) 17	(t _{h12}) 0				
D	CP	-	-	(t _{s13}) 44	(t _{h13}) 1				
D	DLE	(t _{s6}) 10	(t _{h6}) 6	-	-				
DLE	CP	-	-	(t _{s14}) 42	(t _{h14}) 0				

†Timing for immediate instruction for first cycle.

†† Status register and accumulator destination only.

Notes on Testing

Incoming test procedures on this device should be careful planned, taking into account the high complexity and power levels of the part. The following notes may be useful:

1. Insure the part is adequately decoupled at the test head. Large changes in V_{CC} current as the device switches may cause erroneous function failure due to V_{CC} changes.
2. Do not leave inputs floating during any tests, as they may start to oscillate at high frequency.
3. Do not attempt to perform threshold tests at high speed. Following an input transition, ground current may change by as much as 400 mA in 5-8 ns. Inductance in the ground

cable may allow may allow the ground pin at the device to rise by 100s of millivolts momentarily.

4. Use extreme care in defining input levels for AC tests. Many inputs may be changed at once, so there will be significant noise at the device pins and they may not actually reach V_{IL} or V_{IH} until the noise has settled. AMD recommends using $V_{IL} \leq 0$ V and $V_{IH} \geq 3.0$ V for AC tests.
5. To simplify failure analysis, programs should be designed to perform DC, Function, and AC tests as three distinct groups of tests.
6. To assist in testing, AMD offers complete documentation on our test procedures and, in most cases, can provide Fairchild Sentry programs, under license.
7. At air velocity of 300 linear feet per minute.

SWITCHING WAVEFORMS

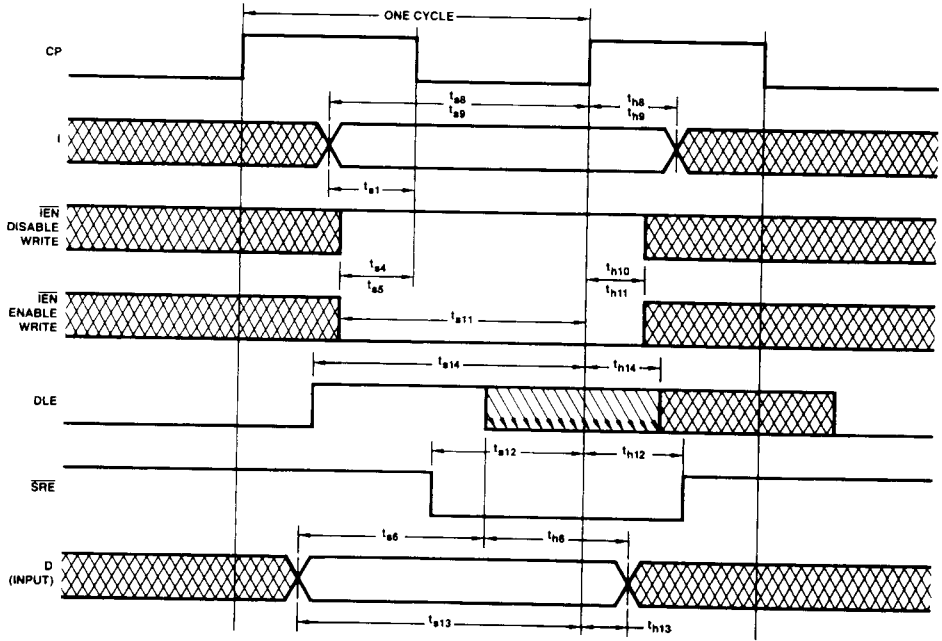

WF002561

Single Address Access Timing

If t_{h6} is satisfied, t_{h13} need not be satisfied.

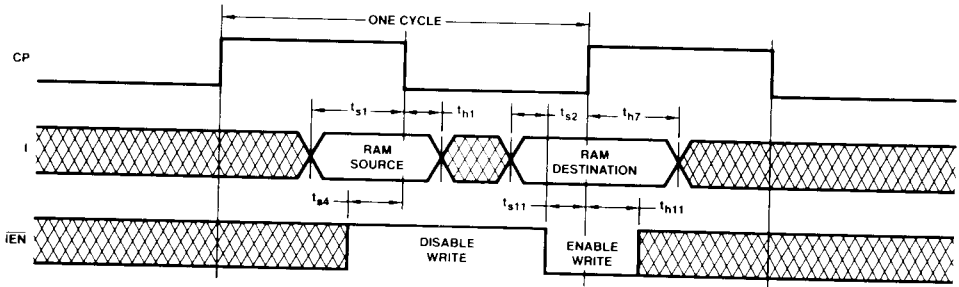

WF002540

Double Address Access Timing

SWITCHING WAVEFORMS (Cont.)

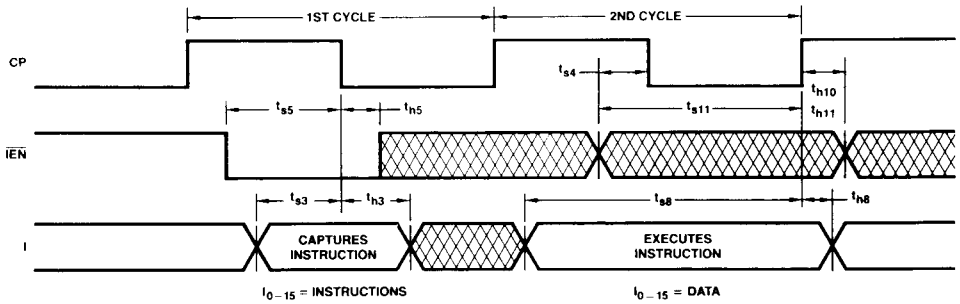

WF002550

One-Address Immediate Instruction Cycle Timing

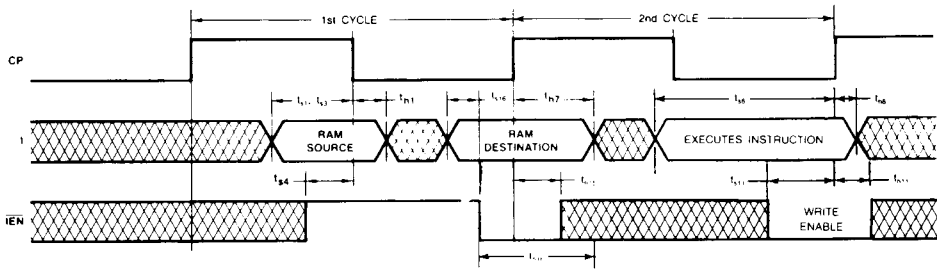

WF002542

Two-Address Immediate Instruction Timing

SWITCHING TEST CIRCUITS

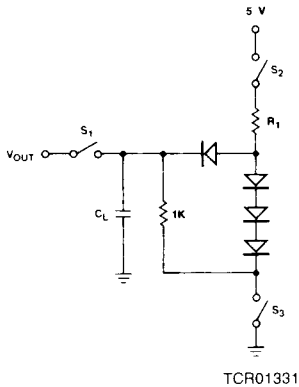

A. Three-State Outputs

$$R_1 = 300 \Omega$$

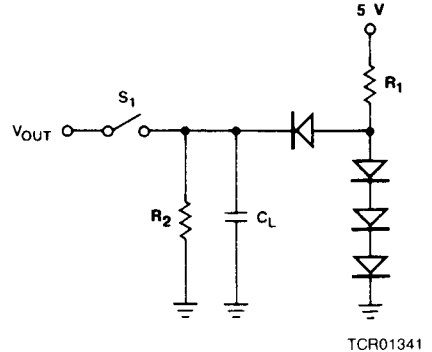

B. Normal Outputs

$$R_1 = 300 \Omega$$

$$R_2 = 3.0 \text{ k}\Omega$$

- Notes:
1. $C_L = 50 \text{ pF}$ includes scope probe, wiring and stray capacitances without device in test fixture.
 2. S_1, S_2, S_3 are closed during function tests and all AC tests except output enable tests.
 3. S_1 and S_3 are closed while S_2 is open for t_{pZH} test.
 S_1 and S_2 are closed while S_3 is open for t_{pZL} test.
 4. $C_L = 5.0 \text{ pF}$ for output disable tests.

SWITCHING TEST WAVEFORMS

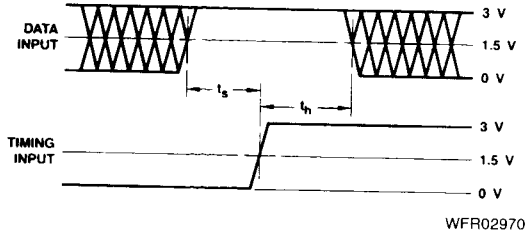

Set-up, Hold, and Release Times

- Notes: 1. Diagram shown for HIGH data only. Output transition may be opposite sense.
 2. Cross hatched area is don't care condition.

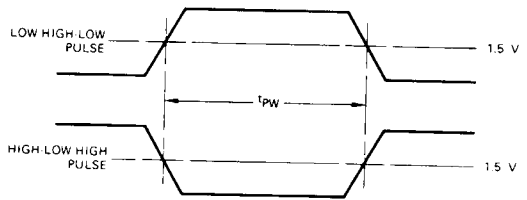

Pulse Width

- Note: 1. Pulse generator for all pulses
 Rate ≤ 1.0 MHz; $Z_O = 50 \Omega$;
 $t_r \leq 2.5$ ns; $t_f \leq 2.5$ ns.

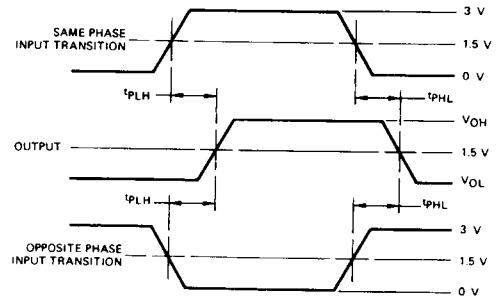

Propagation Delay

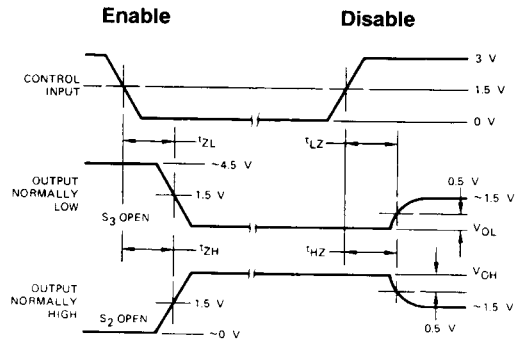

Enable and Disable Times

- Notes: 1. Diagram shown for Input Control Enable-LOW and Input Control Disable-HIGH
 2. S_1 , S_2 and S_3 of Load Circuit are closed except where shown.

INPUT/OUTPUT CURRENT INTERFACE

TTL

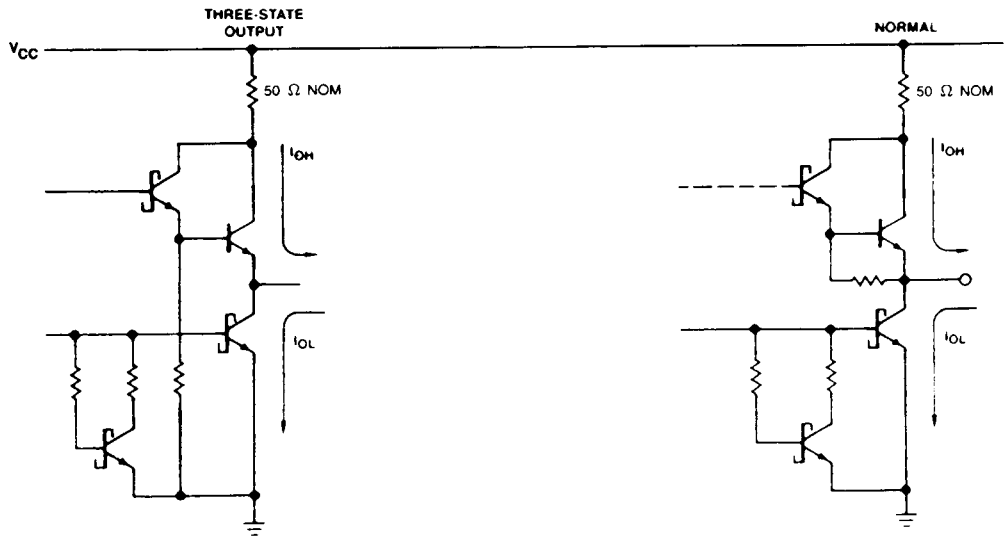

ICR00523

$C_O \cong 5.0$ pF, all outputs

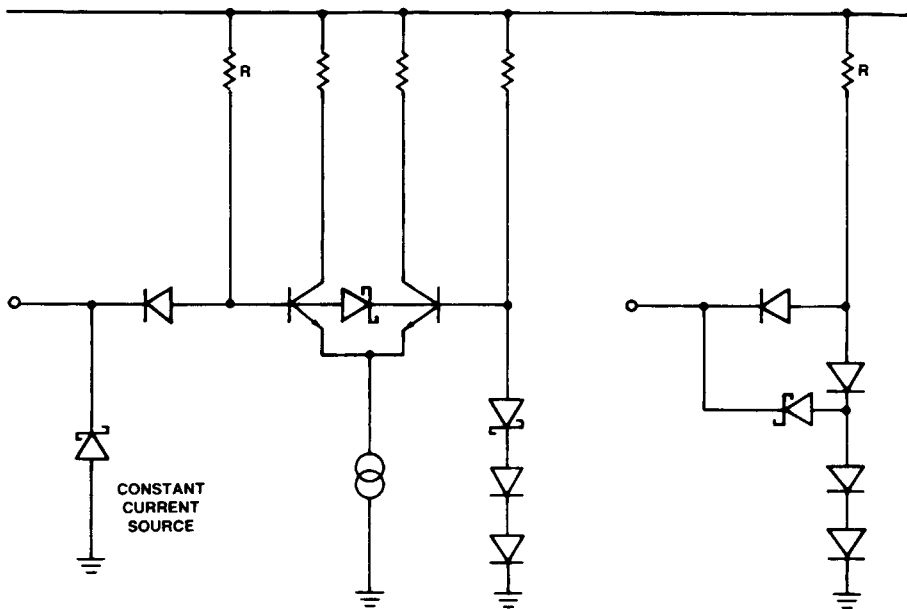

ICR00531

PHYSICAL DIMENSIONS

CG068

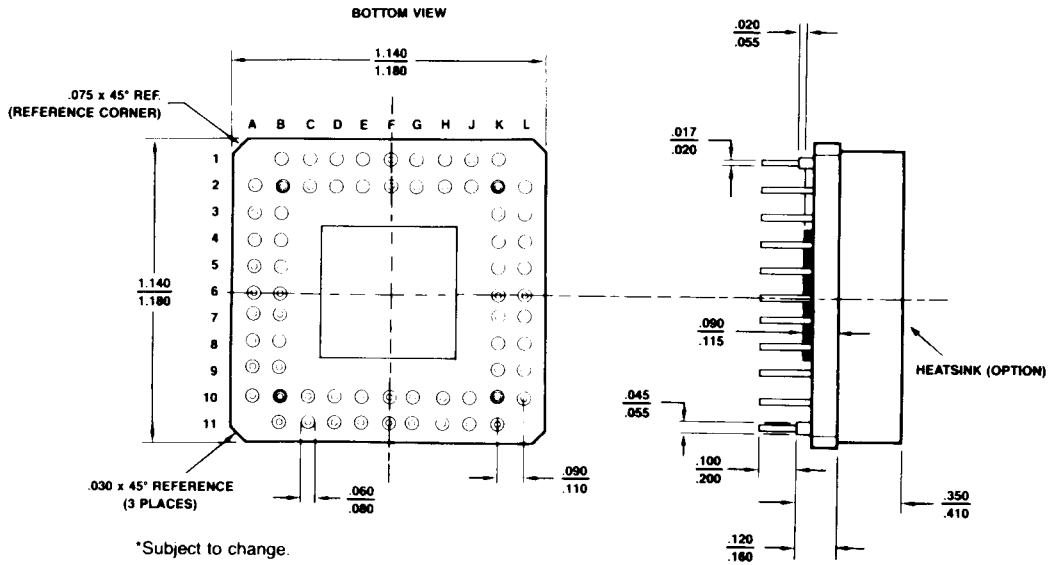

07547A

The International Standard of
Quality guarantees a 0.05% AQL on all
electrical parameters, AC and DC,
over the entire operating range.

INT·STD·500

ADVANCED MICRO DEVICES DOMESTIC SALES OFFICES

ALABAMA	(205) 882-9122	MASSACHUSETTS	(617) 273-3970
ARIZONA,		MINNESOTA	(612) 938-0001
Tempe	(602) 242-4400	NEW JERSEY	(201) 299-0002
Tucson	(602) 792-1200	NEW YORK,	
CALIFORNIA,		Liverpool	(315) 457-5400
El Segundo	(213) 640-3210	Poughkeepsie	(914) 471-8180
Newport Beach	(714) 752-6262	Woodbury	(516) 364-8020
San Diego	(619) 560-7030	NORTH CAROLINA,	
Sunnyvale	(408) 720-8811	Charlotte	(704) 525-1875
Woodland Hills	(818) 992-4155	Raleigh	(919) 847-8471
COLORADO	(303) 691-5100	OREGON	(503) 245-0080
CONNECTICUT,		OHIO,	
Southbury	(203) 264-7800	Columbus	(614) 891-6455
FLORIDA,		PENNSYLVANIA,	
Altamonte Springs	(305) 339-5022	Allentown	(215) 398-8006
Clearwater	(813) 530-9971	Willow Grove	(215) 657-3101
Ft. Lauderdale	(305) 484-8600	TEXAS,	
Melbourne	(305) 254-2915	Austin	(512) 346-7830
GEORGIA	(404) 449-7920	Dallas	(214) 934-9099
ILLINOIS	(312) 773-4422	Houston	(713) 785-9001
INDIANA	(317) 244-7207	WASHINGTON	(206) 455-3600
KANSAS	(913) 451-3115	WISCONSIN	(414) 782-7748
MARYLAND	(301) 796-9310		

INTERNATIONAL SALES OFFICES

BELGIUM,		HONG KONG,	
Bruxelles	TEL: (02) 771 99 93	Kowloon	TEL: 3-695377
	FAX: 762-3716		FAX: 1234276
	TLX: 61028		TLX: 50426
CANADA, Ontario,		ITALY, Milano	TEL: (02) 3390541
Kanata	TEL: (613) 592-0060		FAX: 3498000
Willowdale	TEL: (416) 224-5193		TLX: 315286
	FAX: (416) 224-0056	JAPAN, Tokyo	TEL: (03) 345-8241
FRANCE,			FAX: 3425196
Paris	TEL: (01) 687.36.66		TLX: J24064 AMDTKOJ
	FAX: 6862185	LATIN AMERICA,	
	TLX: 20253	Ft. Lauderdale,	TEL: (305) 484-8600
GERMANY,			FAX: (305) 485-9736
Hannover area	TEL: (05143) 50 55	SWEDEN, Stockholm	TEL: (08) 733 03 50
	FAX: 5553		FAX: 7332285
	TLX: 925287		TLX: 11602
München	TEL: (089) 41 14-0	UNITED KINGDOM,	
	FAX: 406490	Manchester area	TEL: (0925) 828008
	TLX: 523883		FAX: 827693
Stuttgart	TEL: (0711) 62 33 77		TLX: 628524
	FAX: 625187	London area	TEL: (04862) 22121
	TLX: 721882		FAX: 22179
			TLX: 859103

NORTH AMERICAN REPRESENTATIVES

CALIFORNIA		NEW JERSEY	
I ² INC	OEM (408) 988-3400	TAI CORPORATION	(609) 933-2600
	DISTI (408) 498-6868	NEW MEXICO	
CONNECTICUT		THORSON DESERT STATES	(505) 293-8555
SCIENTIFIC COMPONENTS	(203) 272-2963	NEW YORK	
IDAHO		NYCOM, INC	(315) 437-8343
INTERMOUNTAIN TECH MKGT	(208) 322-5022	OHIO	
INDIANA		Dayton	
SAI MARKETING CORP	(317) 241-9276	DOLFUSS ROOT & CO	(513) 433-6776
IOWA		Strongsville	
LORENZ SALES	(319) 377-4666	DOLFUSS ROOT & CO	(216) 238-0300
MICHIGAN		PENNSYLVANIA	
SAI MARKETING CORP	(313) 227-1786	DOLFUSS ROOT & CO	(412) 221-4420
NEBRASKA		UTAH	
LORENZ SALES	(402) 475-4660	R ² MARKETING	(801) 595-0631

Advanced Micro Devices reserves the right to make changes in its product without notice in order to improve design or performance characteristics. The performance characteristics listed in this document are guaranteed by specific tests, correlated testing, guard banding, design and other practices common to the industry. For specific testing details, contact your local AMD sales representative. The company assumes no responsibility for the use of any circuits described herein.



ADVANCED MICRO DEVICES 901 Thompson Pl., P.O. Box 3453, Sunnyvale, CA 94088, USA
 TEL: (408) 732-2400 • TWX: 910-339-9280 • TELEX: 34-6306 • TOLL FREE: (800) 538-8450

© 1985 Advanced Micro Devices, Inc.
 Printed in U.S.A. AMT-B-15M-10/85-0

This datasheet has been downloaded from:

www.DatasheetCatalog.com

Datasheets for electronic components.



LittleDiode supplies new, hard to find or obsolete electronic components and semiconductors all over the world.

With over two million different components listed you are sure to find the part you need.

Feel free to visit us today at our online store:

LittleDiode.com

Looking forward to providing you with the best possible service.