

DATA SHEET

74ALS251

8-input multiplexer (3-State)

Product specification
IC05 Data Handbook

1991 Feb 08

8-input multiplexer (3-State)

74ALS251

FEATURES

- 8-to-1 multiplexing
- On chip decoding
- Multifunction capability
- Inverting and non-inverting outputs
- Both outputs are 3-State for further multiplexer expansion

DESCRIPTION

The 74ALS251 is a logic implementation of a single 8-position switch with the switch position controlled by the state of three select (S0, S1, S2) inputs. True (Y) and complementary (Ȳ) outputs are both provided.

The output enable (\overline{OE}) is active Low. When \overline{OE} is High, both outputs are in High impedance state, allowing multiple connections to a common bus without driving nor loading the bus significantly.

When the outputs of more than one device are tied together, the user must ensure that there is no overlap in the active-Low portion of the output enable voltages in order to avoid high currents that could exceed the maximum current rating.

PIN CONFIGURATION

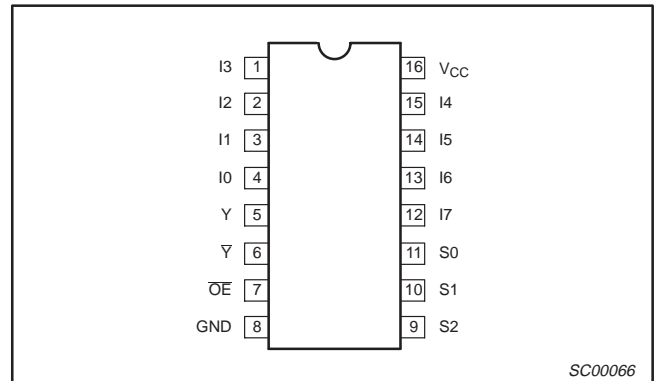

SC00066

ORDERING INFORMATION

DESCRIPTION	ORDER CODE	DRAWING NUMBER
	COMMERCIAL RANGE $V_{CC} = 5V \pm 10\%$, $T_{amb} = 0^{\circ}C$ to $+70^{\circ}C$	
16-pin plastic DIP	74ALS251N	SOT38-4
16-pin plastic SO	74ALS251D	SOT109-1

TYPE	TYPICAL PROPAGATION DELAY	TYPICAL SUPPLY CURRENT (TOTAL)
74ALS251	7.0ns	7.5mA

INPUT AND OUTPUT LOADING AND FAN-OUT TABLE

PINS	DESCRIPTION	74ALS (U.L.) HIGH/LOW	LOAD VALUE HIGH/LOW
I0 – I7	Data inputs	1.0/1.0	20µA/0.1mA
S0 – S2	Select inputs	1.0/1.0	20µA/0.1mA
\overline{OE}	Output Enable input (active-Low)	1.0/1.0	20µA/0.1mA
Y, Ȳ	Data outputs	130/240	2.5mA/24mA

NOTE: One (1.0) ALS unit load is defined as: 20µA in the High state and 0.1mA in the Low state.

LOGIC SYMBOL

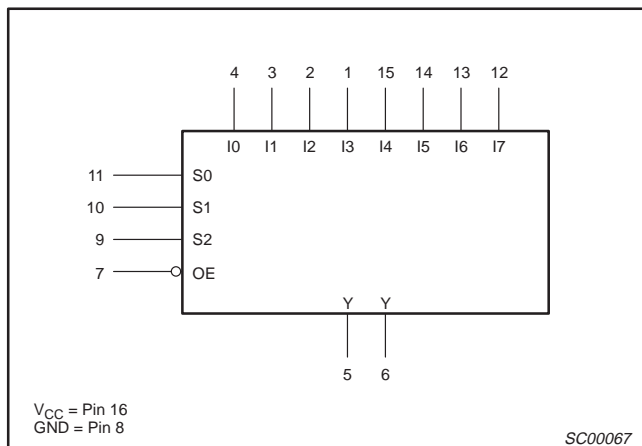

IEC/IEEE SYMBOL

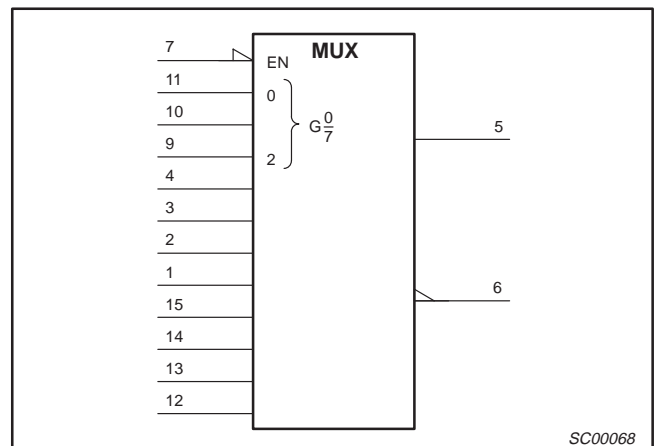

8-input multiplexer (3-State)

74ALS251

LOGIC DIAGRAM

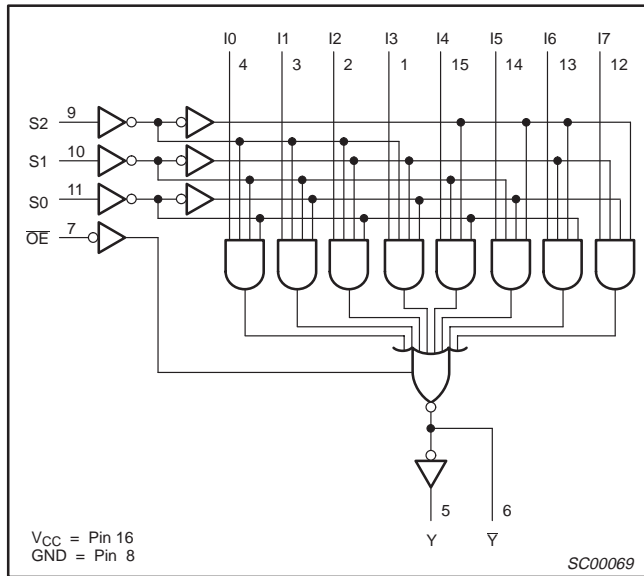

FUNCTION TABLE

INPUTS				OUTPUTS	
S2	S1	S0	OE	Y	Ȳ
X	X	X	H	Z	Z
L	L	L	L	I0	Ī0
L	L	H	L	I1	Ī1
L	H	L	L	I2	Ī2
L	H	H	L	I3	Ī3
H	L	L	L	I4	Ī4
H	L	H	L	I5	Ī5
H	H	L	L	I6	Ī6
H	H	H	L	I7	Ī7

H = High voltage level
 L = Low voltage level
 X = Don't care
 Z = High impedance "off" state

ABSOLUTE MAXIMUM RATINGS

(Operation beyond the limit set forth in this table may impair the useful life of the device. Unless otherwise noted these limits are over the operating free air temperature range.)

SYMBOL	PARAMETER	RATING	UNIT
V _{CC}	Supply voltage	-0.5 to +7.0	V
V _{IN}	Input voltage	-0.5 to +7.0	V
I _{IN}	Input current	-30 to +5	mA
V _{OUT}	Voltage applied to output in High output state	-0.5 to V _{CC}	V
I _{OUT}	Current applied to output in Low output state	48	mA
T _{amb}	Operating free-air temperature range	0 to +70	°C
T _{stg}	Storage temperature range	-65 to +150	°C

RECOMMENDED OPERATING CONDITIONS

SYMBOL	PARAMETER	LIMITS			UNIT
		MIN	NOM	MAX	
V _{CC}	Supply voltage	4.5	5.0	5.5	V
V _{IH}	High-level input voltage	2.0			V
V _{IL}	Low-level input voltage			0.8	V
I _{IK}	Input clamp current			-18	mA
I _{OH}	High-level output current			-2.6	mA
I _{OL}	Low-level output current			24	mA
T _{amb}	Operating free-air temperature range	0		+70	°C

8-input multiplexer (3-State)

74ALS251

DC ELECTRICAL CHARACTERISTICS

(Over recommended operating free-air temperature range unless otherwise noted.)

SYMBOL	PARAMETER	TEST CONDITIONS ¹	LIMITS			UNIT	
			MIN	TYP ²	MAX		
V _{OH}	High-level output voltage	V _{CC} ±10%, V _{IL} = MAX, V _{IH} = MIN	I _{OH} = -0.4mA	V _{CC} - 2		V	
			I _{OH} = -2.6mA	2.4	3.2	V	
V _{OL}	Low-level output voltage	V _{CC} = MIN, V _{IL} = MAX, V _{IH} = MIN	I _{OL} = 12mA		0.25	0.40	V
			I _{OL} = 24mA		0.35	0.50	V
V _{IK}	Input clamp voltage	V _{CC} = MIN, I _I = I _{IK}		-0.73	-1.5	V	
I _I	Input current at maximum input voltage	V _{CC} = MAX, V _I = 7.0V			0.1	mA	
I _{IH}	High-level input current	V _{CC} = MAX, V _I = 2.7V			20	μA	
I _{IL}	Low-level input current	V _{CC} = MAX, V _I = 0.4V			-0.1	mA	
I _{OZH}	Off-state output current, High-level voltage applied	V _{CC} = MAX, V _I = 2.7V			20	μA	
I _{OZL}	Off-state output current, Low-level voltage applied	V _{CC} = MAX, V _I = 0.4V			-20	μA	
I _O	Output current ³	V _{CC} = MAX, V _O = 2.25V	-30		-112	mA	
I _{CC}	Supply current (total)	I _{CC} I _{CCZ}	V _{CC} = MAX		7.0	10	mA
					9.0	14	mA

NOTES:

- For conditions shown as MIN or MAX, use the appropriate value specified under recommended operating conditions for the applicable type.
- All typical values are at V_{CC} = 5V, T_{amb} = 25°C.
- The output conditions have been chosen to produce a current that closely approximates one half of the true short-circuit output current, I_{OS}.

AC ELECTRICAL CHARACTERISTICS

SYMBOL	PARAMETER	TEST CONDITION	LIMITS		UNIT
			T _{amb} = 0°C to +70°C V _{CC} = +5.0V ± 10% C _L = 50pF, R _L = 500Ω		
			MIN	MAX	
t _{PLH} t _{PHL}	Propagation delay In to Y	Waveform 2	4.0 4.0	12.0 12.0	ns
t _{PLH} t _{PHL}	Propagation delay In to \bar{Y}	Waveform 1	3.0 6.0	10.0 15.0	ns
t _{PLH} t _{PHL}	Propagation delay Sn to Y	Waveform 1, 2	5.0 7.0	15.0 16.0	ns
t _{PLH} t _{PHL}	Propagation delay Sn to \bar{Y}	Waveform 1, 2	8.0 5.0	17.0 15.0	ns
t _{PZH} t _{PZL}	Propagation delay \bar{OE} to Y	Waveform 3 Waveform 4	2.0 3.0	8.0 9.0	ns
t _{PHZ} t _{PLZ}	Propagation delay \bar{OE} to \bar{Y}	Waveform 3 Waveform 4	2.0 1.0	8.0 7.0	ns
t _{PZH} t _{PZL}	Propagation delay \bar{OE} to Y	Waveform 3 Waveform 4	2.0 3.0	8.0 9.0	ns
t _{PHZ} t _{PLZ}	Propagation delay \bar{OE} to \bar{Y}	Waveform 3 Waveform 4	2.0 1.0	8.0 7.0	ns

8-input multiplexer (3-State)

74ALS251

AC WAVEFORMS

For all waveforms, $V_M = 1.3V$.

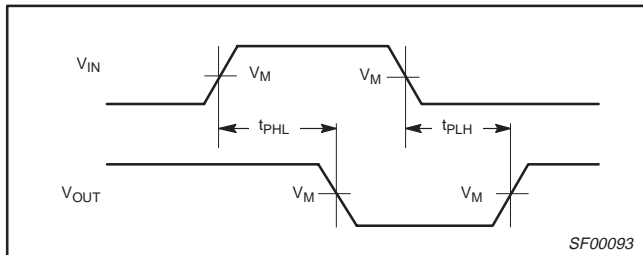

Waveform 1. Propagation Delay for Inverting Output

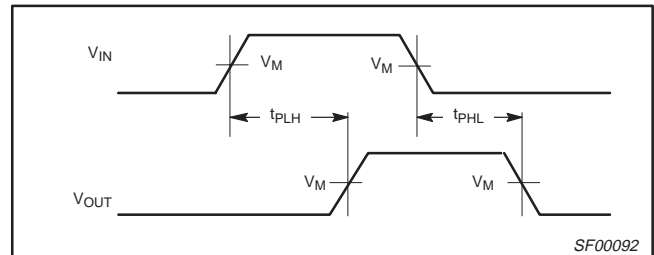

Waveform 2. Propagation Delay for Non-inverting Output

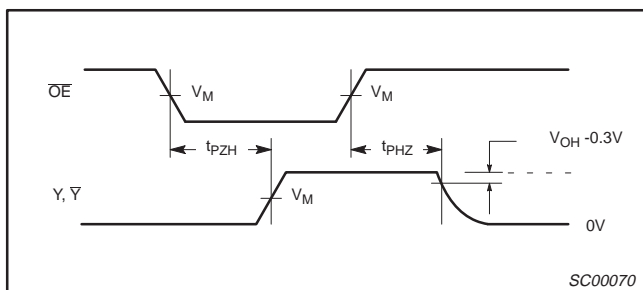

Waveform 3. 3-State Output Enable Time to High Level and Output Disable Time from High Level

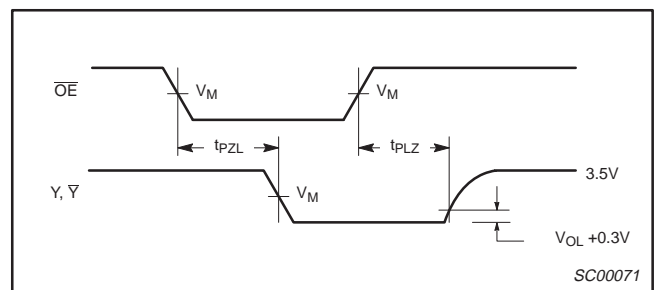

Waveform 4. 3-State Output Enable Time to Low Level and Output Disable Time from Low Level

TEST CIRCUIT AND WAVEFORMS

Test Circuit for 3-State Outputs

SWITCH POSITION	
TEST	SWITCH
t_{PLZ}, t_{PZL}	closed
All other	open

DEFINITIONS:
 R_L = Load resistor; see AC electrical characteristics for value.
 C_L = Load capacitance includes jig and probe capacitance; see AC electrical characteristics for value.
 R_T = Termination resistance should be equal to Z_{OUT} of pulse generators.

Input Pulse Definition

Family	INPUT PULSE REQUIREMENTS					
	Amplitude	V_M	Rep.Rate	t_w	t_{TLH}	t_{THL}
74ALS	3.5V	1.3V	1MHz	500ns	2.0ns	2.0ns

SC00072

8-input multiplexer (3-State)

74ALS251

DIP16: plastic dual in-line package; 16 leads (300 mil)

SOT38-4

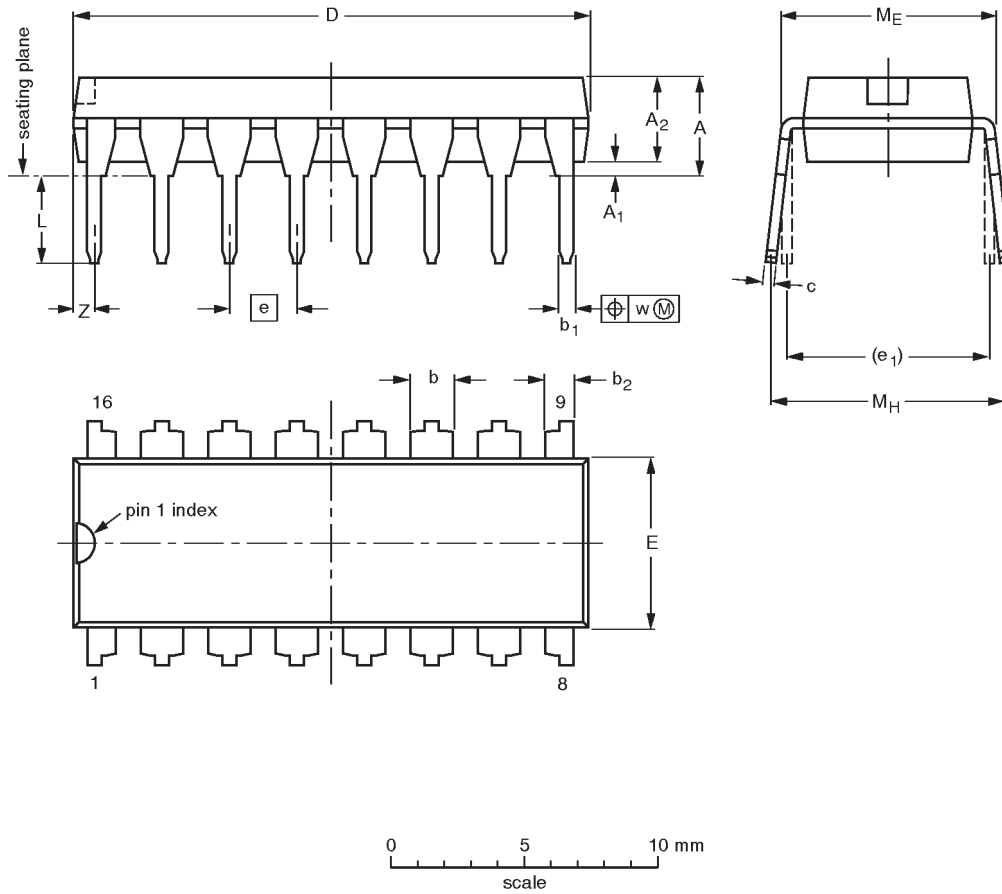

DIMENSIONS (inch dimensions are derived from the original mm dimensions)

UNIT	A max.	A ₁ min.	A ₂ max.	b	b ₁	b ₂	c	D ⁽¹⁾	E ⁽¹⁾	e	e ₁	L	M _E	M _H	w	Z ⁽¹⁾ max.
mm	4.2	0.51	3.2	1.73 1.30	0.53 0.38	1.25 0.85	0.36 0.23	19.50 18.55	6.48 6.20	2.54	7.62	3.60 3.05	8.25 7.80	10.0 8.3	0.254	0.76
inches	0.17	0.020	0.13	0.068 0.051	0.021 0.015	0.049 0.033	0.014 0.009	0.77 0.73	0.26 0.24	0.10	0.30	0.14 0.12	0.32 0.31	0.39 0.33	0.01	0.030

Note

1. Plastic or metal protrusions of 0.25 mm maximum per side are not included.

OUTLINE VERSION	REFERENCES				EUROPEAN PROJECTION	ISSUE DATE
	IEC	JEDEC	EIAJ			
SOT38-4						-92-11-17 95-01-14

8-input multiplexer (3-State)

74ALS251

SO16: plastic small outline package; 16 leads; body width 3.9 mm

SOT109-1

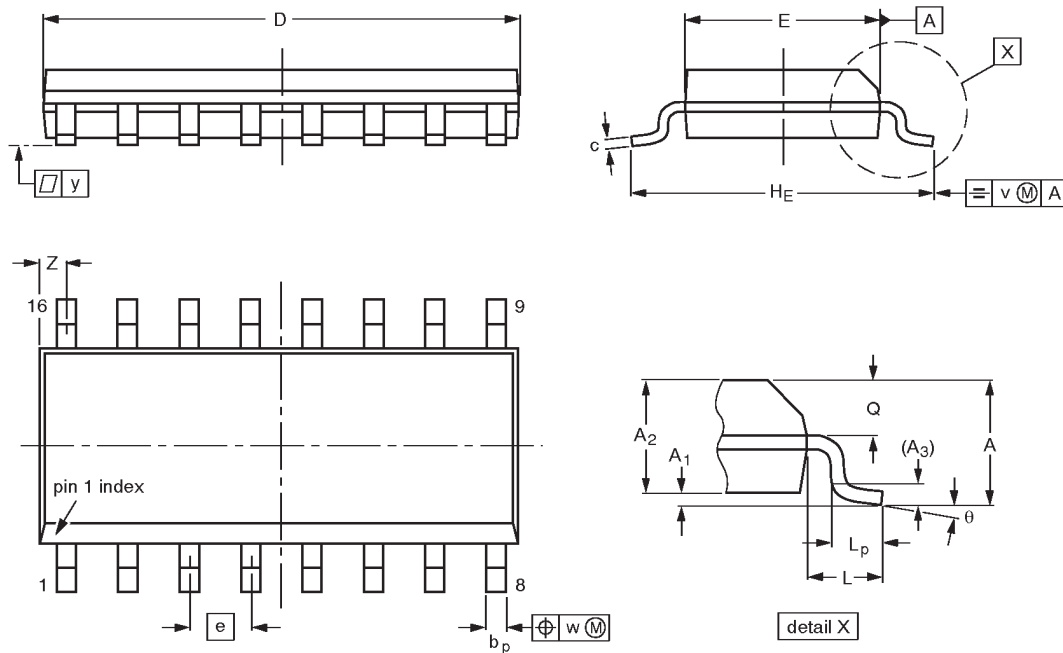

DIMENSIONS (inch dimensions are derived from the original mm dimensions)

UNIT	A max.	A ₁	A ₂	A ₃	b _p	c	D ⁽¹⁾	E ⁽¹⁾	e	H _E	L	L _p	Q	v	w	y	z ⁽¹⁾	θ
mm	1.75	0.25 0.10	1.45 1.25	0.25	0.49 0.36	0.25 0.19	10.0 9.8	4.0 3.8	1.27	6.2 5.8	1.05	1.0 0.4	0.7 0.6	0.25	0.25	0.1	0.7 0.3	8° 0°
inches	0.069	0.0098 0.0039	0.057 0.049	0.01	0.019 0.014	0.0098 0.0075	0.39 0.38	0.16 0.15	0.050	0.24 0.23	0.041	0.039 0.016	0.028 0.020	0.01	0.01	0.004	0.028 0.012	

Note

1. Plastic or metal protrusions of 0.15 mm maximum per side are not included.

OUTLINE VERSION	REFERENCES				EUROPEAN PROJECTION	ISSUE DATE
	IEC	JEDEC	EIAJ			
SOT109-1	076E07S	MS-012AC				91-08-13 95-01-23

8-input multiplexer (3-State)

74ALS251

DEFINITIONS

Data Sheet Identification	Product Status	Definition
<i>Objective Specification</i>	Formative or in Design	This data sheet contains the design target or goal specifications for product development. Specifications may change in any manner without notice.
<i>Preliminary Specification</i>	Preproduction Product	This data sheet contains preliminary data, and supplementary data will be published at a later date. Philips Semiconductors reserves the right to make changes at any time without notice in order to improve design and supply the best possible product.
<i>Product Specification</i>	Full Production	This data sheet contains Final Specifications. Philips Semiconductors reserves the right to make changes at any time without notice, in order to improve design and supply the best possible product.

Philips Semiconductors and Philips Electronics North America Corporation reserve the right to make changes, without notice, in the products, including circuits, standard cells, and/or software, described or contained herein in order to improve design and/or performance. Philips Semiconductors assumes no responsibility or liability for the use of any of these products, conveys no license or title under any patent, copyright, or mask work right to these products, and makes no representations or warranties that these products are free from patent, copyright, or mask work right infringement, unless otherwise specified. Applications that are described herein for any of these products are for illustrative purposes only. Philips Semiconductors makes no representation or warranty that such applications will be suitable for the specified use without further testing or modification.

LIFE SUPPORT APPLICATIONS

Philips Semiconductors and Philips Electronics North America Corporation Products are not designed for use in life support appliances, devices, or systems where malfunction of a Philips Semiconductors and Philips Electronics North America Corporation Product can reasonably be expected to result in a personal injury. Philips Semiconductors and Philips Electronics North America Corporation customers using or selling Philips Semiconductors and Philips Electronics North America Corporation Products for use in such applications do so at their own risk and agree to fully indemnify Philips Semiconductors and Philips Electronics North America Corporation for any damages resulting from such improper use or sale.

Philips Semiconductors
811 East Arques Avenue
P.O. Box 3409
Sunnyvale, California 94088-3409
Telephone 800-234-7381

© Copyright Philips Electronics North America Corporation 1997
 All rights reserved. Printed in U.S.A.

Let's make things better.



LittleDiode supplies new, hard to find or obsolete electronic components and semiconductors all over the world.

With over two million different components listed you are sure to find the part you need.

Feel free to visit us today at our online store:

LittleDiode.com

Looking forward to providing you with the best possible service.