

# DATA SHEET

For a complete data sheet, please also download:

- The IC04 LOCMOS HE4000B Logic Family Specifications HEF, HEC
- The IC04 LOCMOS HE4000B Logic Package Outlines/Information HEF, HEC

## **HEF4724B**

## **MSI**

## **8-bit addressable latch**

Product specification  
File under Integrated Circuits, IC04

January 1995

# 8-bit addressable latch

# HEF4724B MSI

### DESCRIPTION

The HEF4724B is an 8-bit addressable latch with three address inputs ( $A_0$  to  $A_2$ ), a data input ( $D$ ), an active LOW enable input ( $\bar{E}$ ), an active HIGH clear input ( $CL$ ), and eight parallel latch outputs ( $O_0$  to  $O_7$ ).

When  $\bar{E}$  and  $CL$  are HIGH, all outputs ( $O_0$  to  $O_7$ ) are LOW. Eight-channel demultiplexing or active HIGH 1-of-8 decoding with output enable operation occurs when  $CL$  is HIGH and  $\bar{E}$  is LOW. When  $CL$  and  $\bar{E}$  are LOW, the

selected output ( $O_0$  to  $O_7$ ; determined by  $A_0$  to  $A_2$ ) follows  $D$ . When  $\bar{E}$  goes HIGH, the contents of the latch are stored. When operating in the addressable latch mode ( $\bar{E} = CL = LOW$ ), changing more than one bit of  $A_0$  to  $A_2$  could impose a transient wrong address. Therefore, this should only be done while in the memory mode ( $\bar{E} = HIGH, CL = LOW$ ).

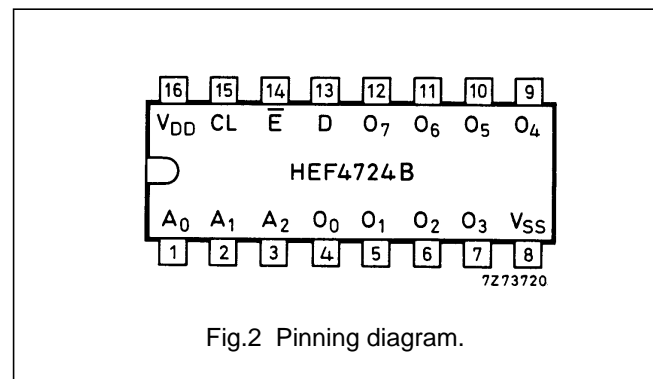
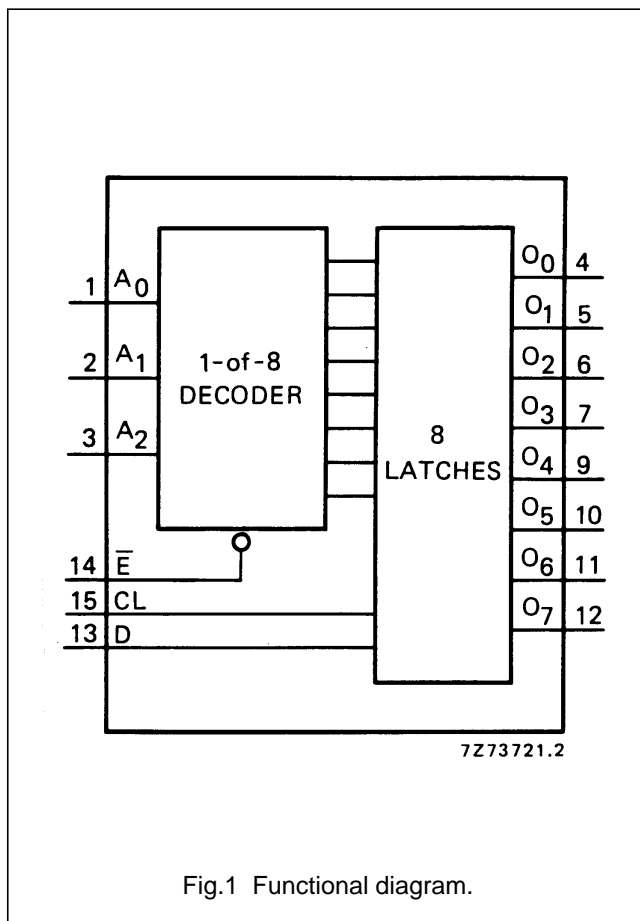

- HEF4724BP(N): 16-lead DIL; plastic (SOT38-1)
- HEF4724BD(F): 16-lead DIL; ceramic (cerdip) (SOT74)
- HEF4724BT(D): 16-lead SO; plastic (SOT109-1)
- ( ): Package Designator North America

### PINNING

- $A_0$  to  $A_2$  address inputs
- $A$  data input
- $\bar{E}$  enable input (active LOW)
- $CL$  clear input (active HIGH)
- $O_0$  to  $O_7$  parallel latch outputs

### FAMILY DATA, $I_{DD}$ LIMITS category MSI

See Family Specifications

### 8-bit addressable latch

HEF4724B  
MSI

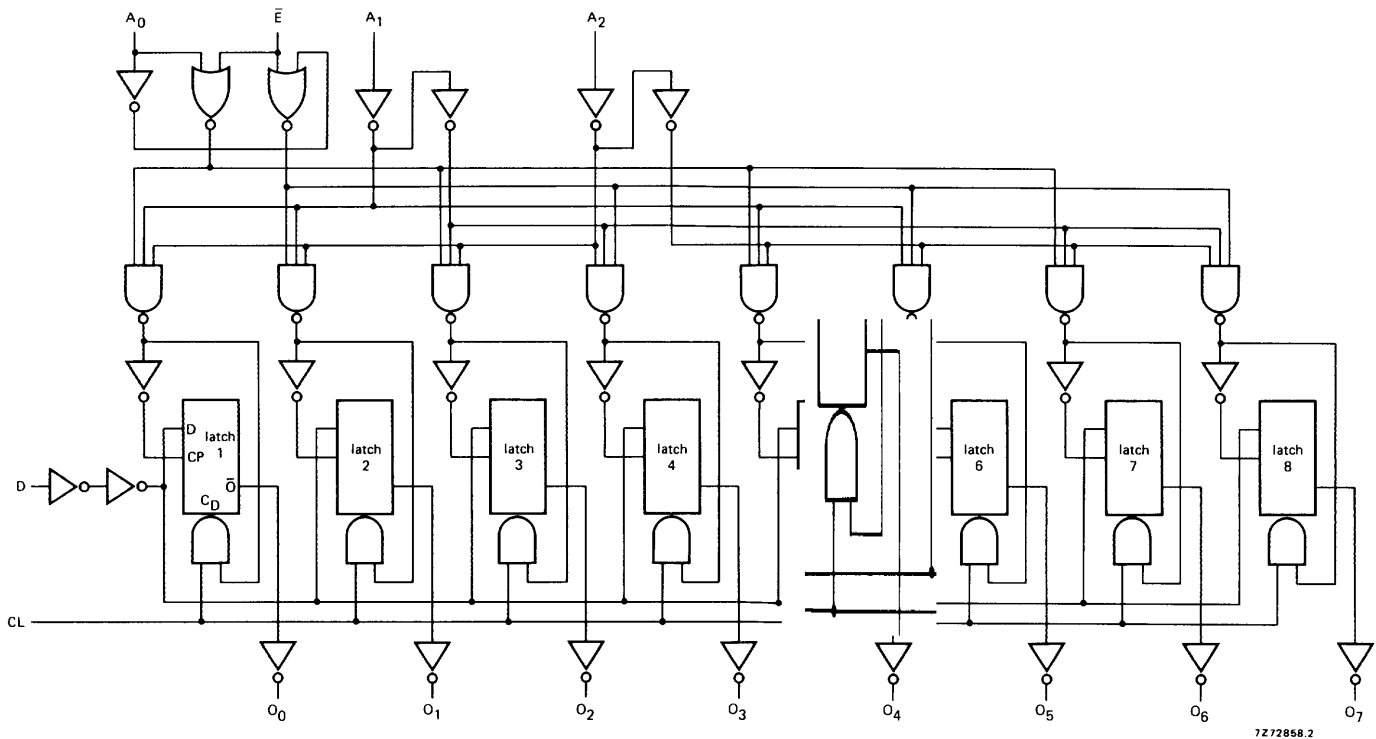

Fig.3 Logic diagram.

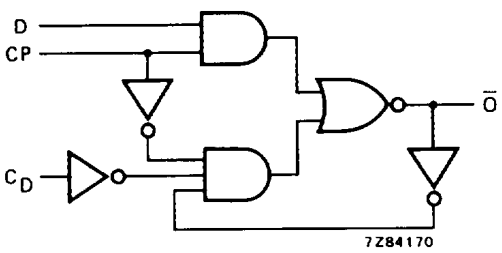

Fig.4 Logic diagram (one latch).

8-bit addressable latch

HEF4724B  
MSI

MODE SELECTION

$\bar{E}$	CL	MODE
L	L	addressable latch
H	L	memory
L	H	active HIGH 8-channel demultiplexer
H	H	clear

FUNCTION TABLE

CL	$\bar{E}$	D	A <sub>0</sub>	A <sub>1</sub>	A <sub>2</sub>	O <sub>0</sub>	O <sub>1</sub>	O <sub>2</sub>	O <sub>3</sub>	O <sub>4</sub>	O <sub>5</sub>	O <sub>6</sub>	O <sub>7</sub>	MODE
H	H	X	X	X	X	L	L	L	L	L	L	L	L	clear
H	L	D <sub>1</sub>	L	L	L	D <sub>1</sub>	L	L	L	L	L	L	L	demultiplexer; unaddressed latch is cleared
H	L	D <sub>1</sub>	H	L	L	L	D <sub>1</sub>	L	L	L	L	L	L	
H	L	D <sub>1</sub>	L	H	L	L	L	D <sub>1</sub>	L	L	L	L	L	
H	L	D <sub>1</sub>	H	H	L	L	L	L	D <sub>1</sub>	L	L	L	L	
H	L	D <sub>1</sub>	L	L	H	L	L	L	L	D <sub>1</sub>	L	L	L	
H	L	D <sub>1</sub>	H	L	H	L	L	L	L	L	D <sub>1</sub>	L	L	
H	L	D <sub>1</sub>	L	H	H	L	L	L	L	L	L	D <sub>1</sub>	L	
H	L	D <sub>1</sub>	H	H	H	L	L	L	L	L	L	L	D <sub>1</sub>	
L	H	X	X	X	X	O <sub>n-1</sub>	O <sub>n-1</sub>	O <sub>n-1</sub>	O <sub>n-1</sub>	O <sub>n-1</sub>	O <sub>n-1</sub>	O <sub>n-1</sub>	O <sub>n-1</sub>	memory
L	L	D <sub>1</sub>	L	L	L	D <sub>1</sub>	O <sub>n-1</sub>	O <sub>n-1</sub>	O <sub>n-1</sub>	O <sub>n-1</sub>	O <sub>n-1</sub>	O <sub>n-1</sub>	O <sub>n-1</sub>	addressable latch; unaddressed latch holds previous state
L	L	D <sub>1</sub>	H	L	L	O <sub>n-1</sub>	D <sub>1</sub>	O <sub>n-1</sub>	O <sub>n-1</sub>	O <sub>n-1</sub>	O <sub>n-1</sub>	O <sub>n-1</sub>	O <sub>n-1</sub>	
L	L	D <sub>1</sub>	L	H	L	O <sub>n-1</sub>	O <sub>n-1</sub>	D <sub>1</sub>	O <sub>n-1</sub>	O <sub>n-1</sub>	O <sub>n-1</sub>	O <sub>n-1</sub>	O <sub>n-1</sub>	
L	L	D <sub>1</sub>	H	H	L	O <sub>n-1</sub>	O <sub>n-1</sub>	O <sub>n-1</sub>	D <sub>1</sub>	O <sub>n-1</sub>	O <sub>n-1</sub>	O <sub>n-1</sub>	O <sub>n-1</sub>	
L	L	D <sub>1</sub>	L	L	H	O <sub>n-1</sub>	O <sub>n-1</sub>	O <sub>n-1</sub>	O <sub>n-1</sub>	D <sub>1</sub>	O <sub>n-1</sub>	O <sub>n-1</sub>	O <sub>n-1</sub>	
L	L	D <sub>1</sub>	H	L	H	O <sub>n-1</sub>	O <sub>n-1</sub>	O <sub>n-1</sub>	O <sub>n-1</sub>	O <sub>n-1</sub>	D <sub>1</sub>	O <sub>n-1</sub>	O <sub>n-1</sub>	
L	L	D <sub>1</sub>	L	H	H	O <sub>n-1</sub>	O <sub>n-1</sub>	O <sub>n-1</sub>	O <sub>n-1</sub>	O <sub>n-1</sub>	O <sub>n-1</sub>	D <sub>1</sub>	O <sub>n-1</sub>	
L	L	D <sub>1</sub>	H	H	H	O <sub>n-1</sub>	O <sub>n-1</sub>	O <sub>n-1</sub>	O <sub>n-1</sub>	O <sub>n-1</sub>	O <sub>n-1</sub>	O <sub>n-1</sub>	D <sub>1</sub>	

Notes

- H = HIGH state (the more positive voltage)  
 L = LOW state (the less positive voltage)  
 X = state is immaterial  
 O<sub>n-1</sub> = state before the positive transition of  $\bar{E}$   
 D<sub>1</sub> = either HIGH or LOW

8-bit addressable latch

HEF4724B  
MSI

**AC CHARACTERISTICS**

$V_{SS} = 0\text{ V}$ ;  $T_{amb} = 25\text{ }^\circ\text{C}$ ; input transition times  $\leq 20\text{ ns}$

	$V_{DD}$ V	TYPICAL FORMULA FOR P ( $\mu\text{W}$ )	
Dynamic power dissipation per package (P)	5 10 15	$700 f_i + \sum (f_o C_L) \times V_{DD}^2$ $3700 f_i + \sum (f_o C_L) \times V_{DD}^2$ $10\ 800 f_i + \sum (f_o C_L) \times V_{DD}^2$	where $f_i$ = input freq. (MHz) $f_o$ = output freq. (MHz) $C_L$ = load capacitance (pF) $\sum (f_o C_L)$ = sum of outputs $V_{DD}$ = supply voltage (V)

**AC CHARACTERISTICS**

$V_{SS} = 0\text{ V}$ ;  $T_{amb} = 25\text{ }^\circ\text{C}$ ;  $C_L = 50\text{ pF}$ ; input transition times  $\leq 20\text{ ns}$

	$V_{DD}$ V	SYMBOL	MIN.	TYP.	MAX.	TYPICAL EXTRAPOLATION FORMULA		
Propagation delays $\bar{E} \rightarrow O_n$ HIGH to LOW	5	$t_{PHL}$		115	230	ns	$88\text{ ns} + (0,55\text{ ns/pF}) C_L$	
	10		50	95	ns	$39\text{ ns} + (0,23\text{ ns/pF}) C_L$		
	15		35	70	ns	$27\text{ ns} + (0,16\text{ ns/pF}) C_L$		
	LOW to HIGH	5	$t_{PLH}$		95	195	ns	$68\text{ ns} + (0,55\text{ ns/pF}) C_L$
		10		40	80	ns	$29\text{ ns} + (0,23\text{ ns/pF}) C_L$	
		15		30	55	ns	$22\text{ ns} + (0,16\text{ ns/pF}) C_L$	
$D \rightarrow O_n$ HIGH to LOW	5	$t_{PHL}$		95	190	ns	$68\text{ ns} + (0,55\text{ ns/pF}) C_L$	
	10		35	75	ns	$24\text{ ns} + (0,23\text{ ns/pF}) C_L$		
	15		25	55	ns	$17\text{ ns} + (0,16\text{ ns/pF}) C_L$		
	LOW to HIGH	5	$t_{PLH}$		85	170	ns	$58\text{ ns} + (0,55\text{ ns/pF}) C_L$
		10		35	75	ns	$24\text{ ns} + (0,23\text{ ns/pF}) C_L$	
		15		25	55	ns	$17\text{ ns} + (0,16\text{ ns/pF}) C_L$	
$A_n \rightarrow O_n$ HIGH to LOW	5	$t_{PHL}$		110	225	ns	$83\text{ ns} + (0,55\text{ ns/pF}) C_L$	
	10		45	95	ns	$34\text{ ns} + (0,23\text{ ns/pF}) C_L$		
	15		35	70	ns	$27\text{ ns} + (0,16\text{ ns/pF}) C_L$		
	LOW to HIGH	5	$t_{PLH}$		95	190	ns	$68\text{ ns} + (0,55\text{ ns/pF}) C_L$
		10		40	80	ns	$29\text{ ns} + (0,23\text{ ns/pF}) C_L$	
		15		30	55	ns	$22\text{ ns} + (0,16\text{ ns/pF}) C_L$	
$CL \rightarrow O_n$ HIGH to LOW	5	$t_{PHL}$		85	165	ns	$58\text{ ns} + (0,55\text{ ns/pF}) C_L$	
	10		35	70	ns	$24\text{ ns} + (0,23\text{ ns/pF}) C_L$		
	15		25	50	ns	$17\text{ ns} + (0,16\text{ ns/pF}) C_L$		

8-bit addressable latch

HEF4724B  
MSI

	V <sub>DD</sub> V	SYMBOL	MIN.	TYP.	MAX.	TYPICAL EXTRAPOLATION FORMULA
Set-up times D → $\bar{E}$	5	t <sub>su</sub>	40	20	ns	see also waveforms Fig.5
	10		15	5	ns	
	15		10	0	ns	
A <sub>n</sub> → $\bar{E}$	5	t <sub>su</sub>	40	20	ns	
	10		20	10	ns	
	15		15	5	ns	
Hold times D → $\bar{E}$	5	t <sub>hold</sub>	20	0	ns	
	10		15	5	ns	
	15		15	5	ns	
A <sub>n</sub> → $\bar{E}$	5	t <sub>hold</sub>	50	25	ns	
	10		20	10	ns	
	15		15	5	ns	
Minimum $\bar{E}$ pulse width; LOW	5	t <sub>WEL</sub>	75	35	ns	
	10		30	15	ns	
	15		20	10	ns	
Minimum CL pulse width; HIGH	5	t <sub>WCLH</sub>	70	35	ns	
	10		30	15	ns	
	15		20	10	ns	

AC CHARACTERISTICS

V<sub>SS</sub> = 0 V; T<sub>amb</sub> = 25 °C; C<sub>L</sub> = 50 pF; input transition times ≤ 20 ns

	V <sub>DD</sub> V	SYMBOL	MIN.	TYP.	MAX.	TYPICAL EXTRAPOLATION FORMULA	
Output transition times HIGH to LOW	5	t <sub>THL</sub>		60	120	ns	10 ns + (1,0 ns/pF) C <sub>L</sub>
	10		30	60	ns	9 ns + (0,42 ns/pF) C <sub>L</sub>	
	15		20	40	ns	6 ns + (0,28 ns/pF) C <sub>L</sub>	
LOW to HIGH	5	t <sub>TLH</sub>		60	120	ns	10 ns + (1,0 ns/pF) C <sub>L</sub>
	10		30	60	ns	9 ns + (0,42 ns/pF) C <sub>L</sub>	
	15		20	40	ns	6 ns + (0,28 ns/pF) C <sub>L</sub>	

8-bit addressable latch

HEF4724B  
MSI

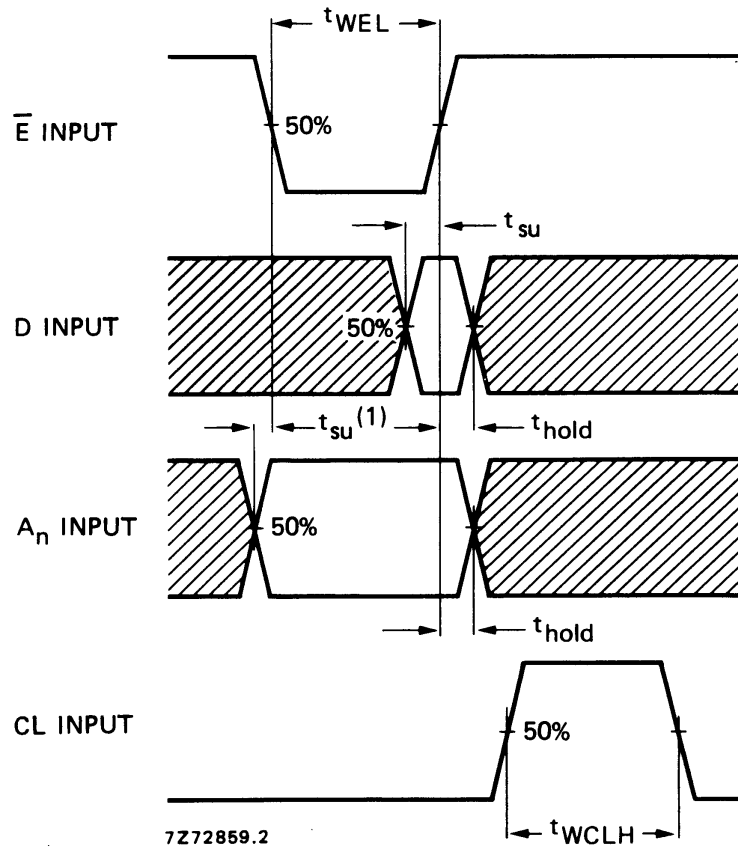

(1) The address to enable set-up time is the time before the HIGH to LOW enable transition that the address must be stable so that the correct latch is addressed and the other latches are not affected.

Fig.5 Waveforms showing minimum  $\bar{E}$  and CL pulse widths, set-up times, hold times. Set-up and hold times are shown as positive values but may be specified as negative values.



LittleDiode supplies new, hard to find or obsolete electronic components and semiconductors all over the world.

With over two million different components listed you are sure to find the part you need.

Feel free to visit us today at our online store:

[LittleDiode.com](http://LittleDiode.com)

Looking forward to providing you with the best possible service.