

Dual 4-input NAND buffer

74F40

TYPE	TYPICAL PROPAGATION DELAY	TYPICAL SUPPLY CURRENT (TOTAL)
74F40	3.5ns	6mA

ORDERING INFORMATION

DESCRIPTION	COMMERCIAL RANGE $V_{CC} = 5V \pm 10\%$, $T_{amb} = 0^{\circ}C$ to $+70^{\circ}C$
14-pin plastic DIP	N74F40N
14-pin plastic SO	N74F40D

PIN CONFIGURATION

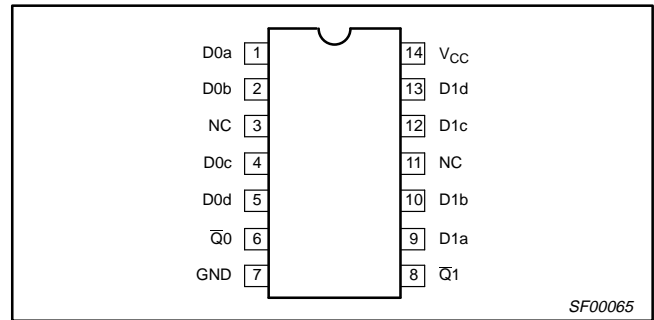

INPUT AND OUTPUT LOADING AND FAN OUT TABLE

PINS	DESCRIPTION	74F (U.L.) HIGH/LOW	LOAD VALUE HIGH/LOW
Dna, Dnb, Dnc, Dnd	Data inputs	1.0/2.0	20μA/1.2mA
$\bar{Q}0, \bar{Q}1$	Data outputs	750/106.7	15mA/64mA

NOTE: One (1.0) FAST unit load is defined as: 20μA in the High state and 0.6mA in the Low state.

LOGIC DIAGRAM

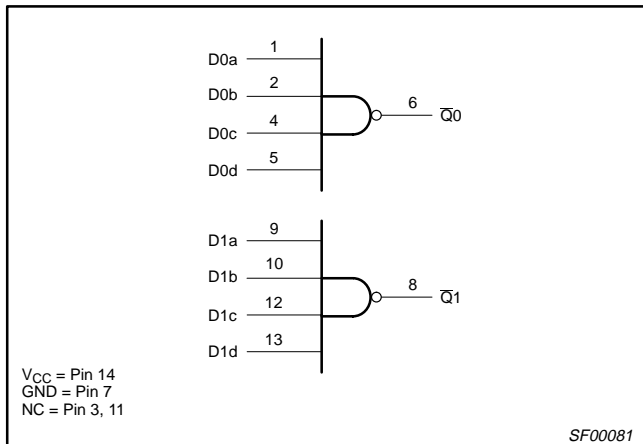

FUNCTION TABLE

INPUTS				OUTPUT
Dna	Dnb	Dnc	Dnd	$\bar{Q}n$
L	X	X	X	H
X	L	X	X	H
X	X	L	X	H
X	X	X	X	H
H	H	H	H	L

NOTES:

1. H = High voltage level
2. L = Low voltage level
3. X = Don't care

LOGIC SYMBOL

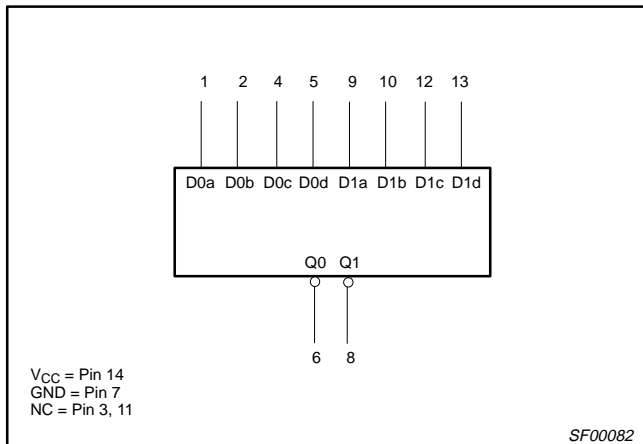

IEC/IEEE SYMBOL

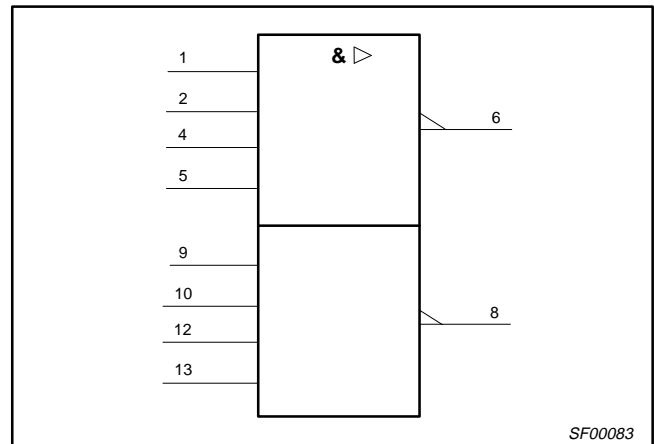

Dual 4-input NAND buffer

74F40

ABSOLUTE MAXIMUM RATINGS

(Operation beyond the limits set forth in this table may impair the useful life of the device.
Unless otherwise noted these limits are over the operating free-air temperature range.)

SYMBOL	PARAMETER	RATING	UNIT
V _{CC}	Supply voltage	-0.5 to +7.0	V
V _{IN}	Input voltage	-0.5 to +7.0	V
I _{IN}	Input current	-30 to +5	mA
V _{OUT}	Voltage applied to output in High output state	-0.5 to V _{CC}	V
I _{OUT}	Current applied to output in Low output state	128	mA
T _{amb}	Operating free-air temperature range	0 to +70	°C
T _{stg}	Storage temperature range	-65 to +150	°C

RECOMMENDED OPERATING CONDITIONS

SYMBOL	PARAMETER	LIMITS			UNIT
		MIN	NOM	MAX	
V _{CC}	Supply voltage	4.5	5.0	5.5	V
V _{IH}	High-level input voltage	2.0			V
V _{IL}	Low-level input voltage			0.8	V
I _{IK}	Input clamp current			-18	mA
I _{OH}	High-level output current			-15	mA
I _{OL}	Low-level output current			64	mA
T _{amb}	Operating free-air temperature range	0		+70	°C

DC ELECTRICAL CHARACTERISTICS

(Over recommended operating free-air temperature range unless otherwise noted.)

SYMBOL	PARAMETER	TEST CONDITIONS ¹	LIMITS			UNIT	
			MIN	TYP ²	MAX		
V _{OH}	High-level output voltage	V _{CC} = MIN, V _{IL} = MAX, V _{IH} = MIN	I _{OH} = -1mA	±10%V _{CC}	2.5		V
				±5%V _{CC}	2.7	3.4	
			I _{OH} = -15mA	±10%V _{CC}	2.0		V
				±5%V _{CC}	2.0		
V _{OL}	Low-level output voltage	V _{CC} = MIN, V _{IL} = MAX, V _{IH} = MIN	I _{OL} = MAX	±10%V _{CC}		0.55	V
				±5%V _{CC}		0.42	
V _{IK}	Input clamp voltage	V _{CC} = MIN, I _I = I _{IK}			-0.73	-1.2	V
I _I	Input current at maximum input voltage	V _{CC} = MAX, V _I = 7.0V				100	μA
I _{IH}	High-level input current	V _{CC} = MAX, V _I = 2.7V				20	μA
I _{IL}	Low-level input current	V _{CC} = MAX, V _I = 0.5V				-0.6	mA
I _{OS}	Short-circuit output current ³	V _{CC} = MAX			-100	-225	mA
I _{CC}	Supply current (total)	V _{CC} = MAX	V _{IN} = GND		1.75	4.0	mA
				V _{IN} = 4.5V		11	

NOTES:

- For conditions shown as MIN or MAX, use the appropriate value specified under recommended operating conditions for the applicable type.
- All typical values are at V_{CC} = 5V, T_{amb} = 25°C.
- Not more than one output should be shorted at a time. For testing I_{OS}, the use of high-speed test apparatus and/or sample-and-hold techniques are preferable in order to minimize internal heating and more accurately reflect operational values. Otherwise, prolonged shorting of a High output may raise the chip temperature well above normal and thereby cause invalid readings in other parameter tests. In any sequence of parameter tests, I_{OS} tests should be performed last.

Dual 4-input NAND buffer

74F40

AC ELECTRICAL CHARACTERISTICS

SYMBOL	PARAMETER	TEST CONDITION	LIMITS					UNIT
			$V_{CC} = +5.0V$ $T_{amb} = +25^{\circ}C$ $C_L = 50pF, R_L = 500\Omega$			$V_{CC} = +5.0V \pm 10\%$ $T_{amb} = 0^{\circ}C \text{ to } +70^{\circ}C$ $C_L = 50pF, R_L = 500\Omega$		
			MIN	TYP	MAX	MIN	MAX	
t_{PLH} t_{PHL}	Propagation delay Dna, Dnb, Dnc, Dnd to \bar{Q}_n	Waveform 1	2.0 1.5	4.0 3.0	6.0 5.0	1.5 1.0	7.0 5.5	ns

AC WAVEFORMS

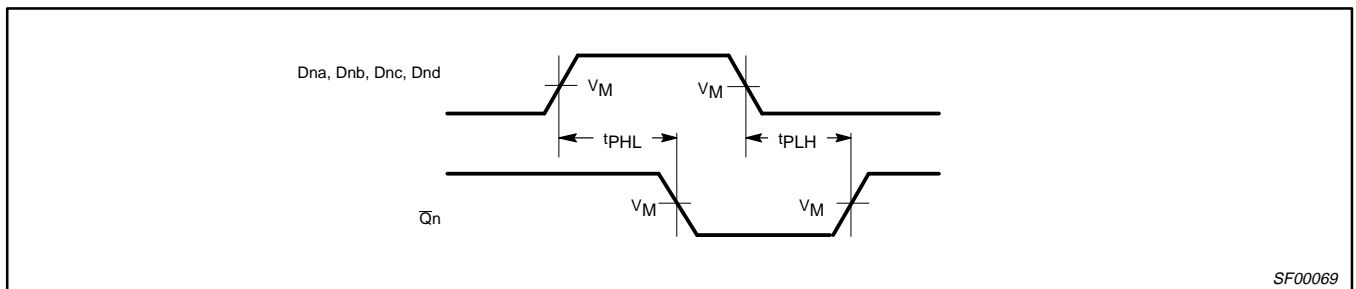

Waveform 1. Propagation Delay for Inverting Outputs

NOTE:

For all waveforms, $V_M = 1.5V$.

TEST CIRCUIT AND WAVEFORMS

Test Circuit for Totem-Pole Outputs

DEFINITIONS:

- R_L = Load resistor; see AC electrical characteristics for value.
- C_L = Load capacitance includes jig and probe capacitance; see AC electrical characteristics for value.
- R_T = Termination resistance should be equal to Z_{OUT} of pulse generators.

Input Pulse Definition

family	INPUT PULSE REQUIREMENTS					
	amplitude	V_M	rep. rate	t_w	t_{TLH}	t_{THL}
74F	3.0V	1.5V	1MHz	500ns	2.5ns	2.5ns



LittleDiode supplies new, hard to find or obsolete electronic components and semiconductors all over the world.

With over two million different components listed you are sure to find the part you need.

Feel free to visit us today at our online store:

LittleDiode.com

Looking forward to providing you with the best possible service.