

# DATA SHEET

For a complete data sheet, please also download:

- The IC06 74HC/HCT/HCU/HCMOS Logic Family Specifications
- The IC06 74HC/HCT/HCU/HCMOS Logic Package Information
- The IC06 74HC/HCT/HCU/HCMOS Logic Package Outlines

## **74HC/HCT137**

**3-to-8 line decoder/demultiplexer  
with address latches; inverting**

Product specification  
File under Integrated Circuits, IC06

December 1990

## 3-to-8 line decoder/demultiplexer with address latches; inverting

## 74HC/HCT137

### FEATURES

- Combines 3-to-8 decoder with 3-bit latch
- Multiple input enable for easy expansion or independent controls
- Active LOW mutually exclusive outputs
- Output capability: standard
- I<sub>CC</sub> category: MSI

### GENERAL DESCRIPTION

The 74HC/HCT137 are high-speed Si-gate CMOS devices and are pin compatible with low power Schottky TTL (LSTTL). They are specified in compliance with JEDEC standard no. 7A.

The 74HC/HCT137 are 3-to-8 line decoder/demultiplexers with latches at the three address inputs (A<sub>n</sub>). The "137" essentially combines the 3-to-8 decoder function with a 3-bit storage latch. When the latch is enabled ( $\overline{LE} = \text{LOW}$ ), the "137" acts as a 3-to-8 active LOW decoder. When the latch enable ( $\overline{LE}$ ) goes from LOW-to-HIGH, the last data present at the inputs before this transition, is stored in the latches. Further address changes are ignored as long as  $\overline{LE}$  remains HIGH.

The output enable input ( $\overline{E}_1$  and E<sub>2</sub>) controls the state of the outputs independent of the address inputs or latch operation. All outputs are HIGH unless  $\overline{E}_1$  is LOW and E<sub>2</sub> is HIGH.

The "137" is ideally suited for implementing non-overlapping decoders in 3-state systems and strobed (stored address) applications in bus oriented systems.

### QUICK REFERENCE DATA

GND = 0 V; T<sub>amb</sub> = 25 °C; t<sub>r</sub> = t<sub>f</sub> = 6 ns

| SYMBOL                              | PARAMETER                                 | CONDITIONS                                    | TYPICAL |     | UNIT |
|-------------------------------------|---|---|---------|-----|------|
|                                     |   |   | HC      | HCT |      |
| t <sub>PHL</sub> / t <sub>PLH</sub> | propagation delay                         | C <sub>L</sub> = 15 pF; V <sub>CC</sub> = 5 V |         |     |      |
|                                     | A <sub>n</sub> to $\overline{Y}_n$        |   | 18      | 19  | ns   |
|                                     | $\overline{LE}$ to $\overline{Y}_n$       |   | 17      | 21  | ns   |
|                                     | $\overline{E}_1$ to $\overline{Y}_n$      |   | 15      | 17  | ns   |
|                                     | E <sub>2</sub> to $\overline{Y}_n$        |   | 15      | 15  | ns   |
| C <sub>I</sub>                      | input capacitance                         |   | 3.5     | 3.5 | pF   |
| C <sub>PD</sub>                     | power dissipation capacitance per package | notes 1 and 2                                 | 57      | 59  | pF   |

### Notes

1. C<sub>PD</sub> is used to determine the dynamic power dissipation (P<sub>D</sub> in μW):

$$P_D = C_{PD} \times V_{CC}^2 \times f_i + \sum (C_L \times V_{CC}^2 \times f_o) \text{ where:}$$

f<sub>i</sub> = input frequency in MHz

f<sub>o</sub> = output frequency in MHz

∑ (C<sub>L</sub> × V<sub>CC</sub><sup>2</sup> × f<sub>o</sub>) = sum of outputs

C<sub>L</sub> = output load capacitance in pF

V<sub>CC</sub> = supply voltage in V

2. For HC the condition is V<sub>1</sub> = GND to V<sub>CC</sub>  
For HCT the condition is V<sub>1</sub> = GND to V<sub>CC</sub> – 1.5 V

### ORDERING INFORMATION

See "74HC/HCT/HCU/HCMOS Logic Package Information".

# 3-to-8 line decoder/demultiplexer with address latches; inverting

74HC/HCT137

## PIN DESCRIPTION

| PIN NO.                      | SYMBOL                               | NAME AND FUNCTION               |
|------------------------------|--------------------------------------|---------------------------------|
| 1, 2, 3                      | $A_0$ to $A_2$                       | data inputs                     |
| 4                            | $\overline{LE}$                      | latch enable input (active LOW) |
| 5                            | $\overline{E}_1$                     | data enable input (active LOW)  |
| 6                            | $E_2$                                | data enable input (active HIGH) |
| 8                            | GND                                  | ground (0 V)                    |
| 15, 14, 13, 12, 11, 10, 9, 7 | $\overline{Y}_0$ to $\overline{Y}_7$ | multiplexer outputs             |
| 16                           | $V_{CC}$                             | positive supply voltage         |

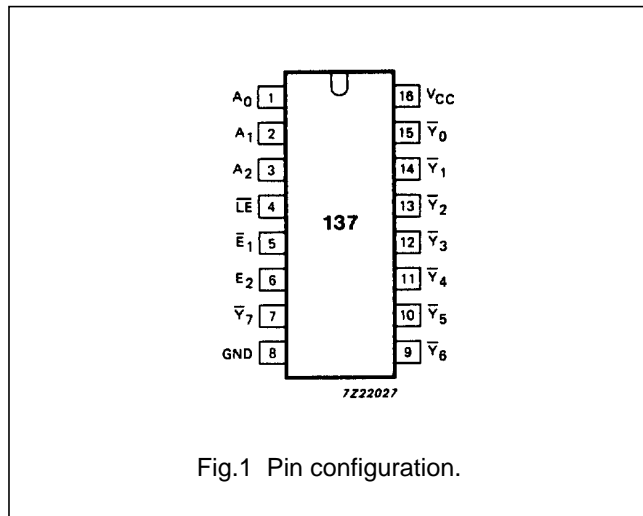

Fig.1 Pin configuration.

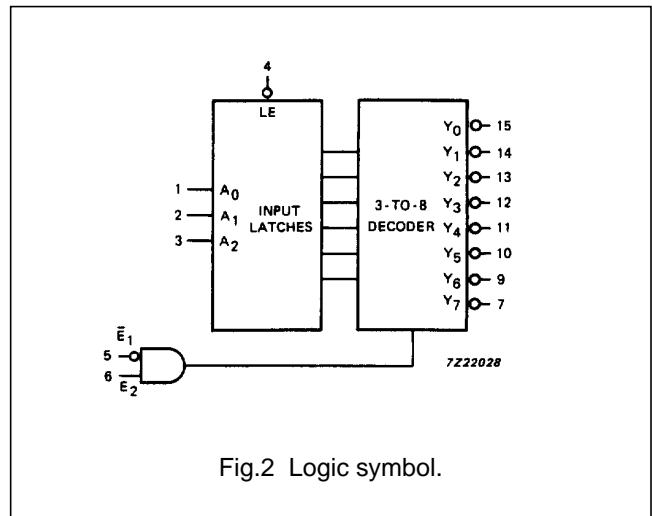

Fig.2 Logic symbol.

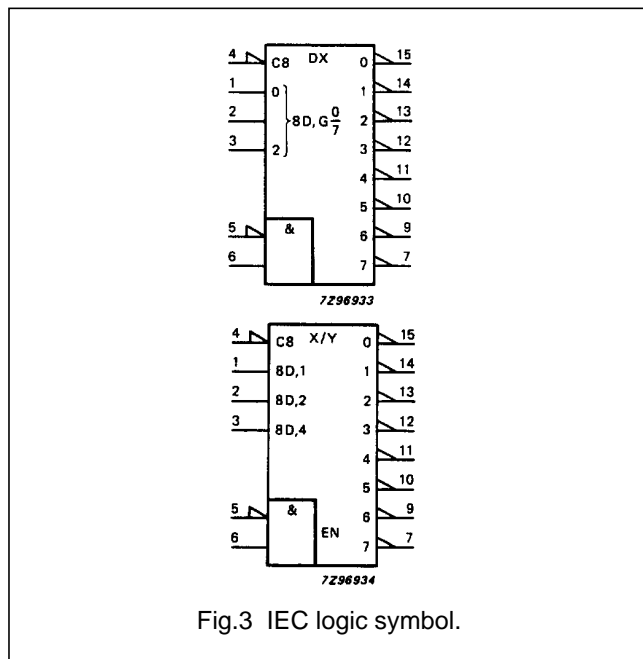

Fig.3 IEC logic symbol.

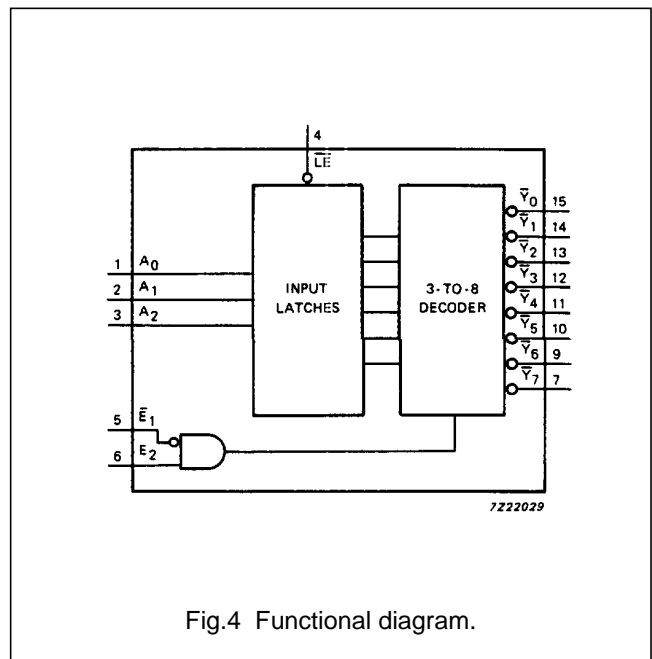

Fig.4 Functional diagram.

# 3-to-8 line decoder/demultiplexer with address latches; inverting

74HC/HCT137

## FUNCTION TABLE

| INPUTS          |                  |       |       |       |       | OUTPUTS          |                  |                  |                  |                  |                  |                  |                  |
|-----------------|------------------|-------|-------|-------|-------|------------------|------------------|------------------|------------------|------------------|------------------|------------------|------------------|
| $\overline{LE}$ | $\overline{E}_1$ | $E_2$ | $A_0$ | $A_1$ | $A_2$ | $\overline{Y}_0$ | $\overline{Y}_1$ | $\overline{Y}_2$ | $\overline{Y}_3$ | $\overline{Y}_4$ | $\overline{Y}_5$ | $\overline{Y}_6$ | $\overline{Y}_7$ |
| H               | L                | H     | X     | X     | X     | stable           |                  |                  |                  |                  |                  |                  |                  |
| X               | H                | X     | X     | X     | X     | H                | H                | H                | H                | H                | H                | H                | H                |
| X               | X                | L     | X     | X     | X     | H                | H                | H                | H                | H                | H                | H                | H                |
| L               | L                | H     | L     | L     | L     | L                | H                | H                | H                | H                | H                | H                | H                |
| L               | L                | H     | H     | L     | L     | H                | L                | H                | H                | H                | H                | H                | H                |
| L               | L                | H     | L     | H     | L     | H                | H                | L                | H                | H                | H                | H                | H                |
| L               | L                | H     | H     | H     | L     | H                | H                | H                | L                | H                | H                | H                | H                |
| L               | L                | H     | L     | L     | H     | H                | H                | H                | H                | L                | H                | H                | H                |
| L               | L                | H     | H     | L     | H     | H                | H                | H                | H                | L                | H                | H                | H                |
| L               | L                | H     | L     | H     | H     | H                | H                | H                | H                | H                | L                | H                | H                |
| L               | L                | H     | H     | H     | H     | H                | H                | H                | H                | H                | H                | L                | H                |

### Notes

- H = HIGH voltage level  
L = LOW voltage level  
X = don't care

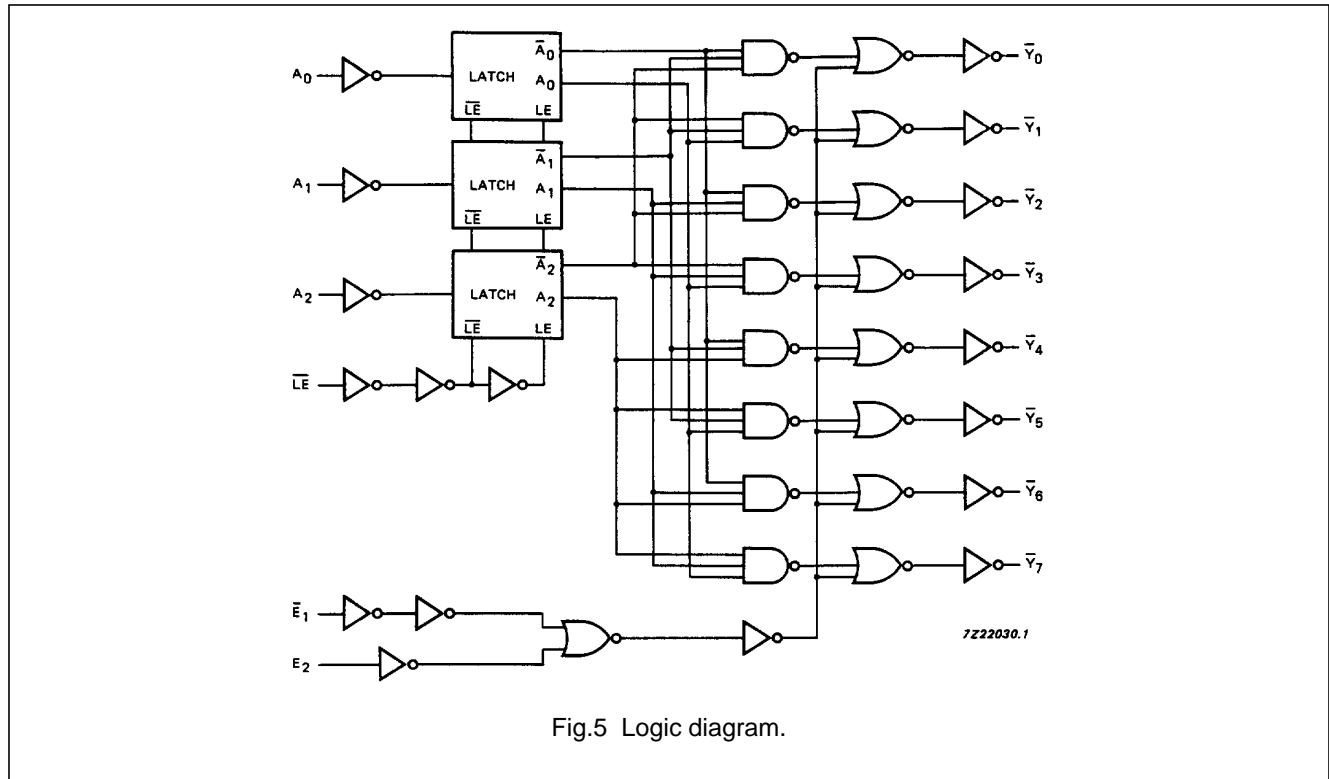

# 3-to-8 line decoder/demultiplexer with address latches; inverting

74HC/HCT137

## DC CHARACTERISTICS FOR 74HC

For the DC characteristics see *"74HC/HCT/HCU/HCMOS Logic Family Specifications"*.

Output capability: standard

I<sub>CC</sub> category: MSI

## AC CHARACTERISTICS FOR 74HC

GND = 0 V; t<sub>r</sub> = t<sub>f</sub> = 6 ns; C<sub>L</sub> = 50 pF

| SYMBOL                              | PARAMETER  | T <sub>amb</sub> (°C) |                |                 |                |                 |                |                 |    | UNIT              | TEST CONDITIONS        |           |
|-------------------------------------|--|-----------------------|----------------|-----------------|----------------|-----------------|----------------|-----------------|----|-------------------|------------------------|-----------|
|                                     |  | 74HC                  |                |                 |                |                 |                |                 |    |                   | V <sub>CC</sub><br>(V) | WAVEFORMS |
|                                     |  | +25                   |                |                 | -40 to +85     |                 | -40 to +125    |                 |    |                   |                        |           |
|                                     |  | min.                  | typ.           | max.            | min.           | max.            | min.           | max.            |    |                   |                        |           |
| t <sub>PHL</sub> / t <sub>PLH</sub> | propagation delay<br>A <sub>n</sub> to $\bar{Y}_n$ |                       | 58<br>21<br>17 | 180<br>36<br>31 |                | 225<br>45<br>38 |                | 270<br>54<br>46 | ns | 2.0<br>4.5<br>6.0 | Fig.6                  |           |
| t <sub>PHL</sub> / t <sub>PLH</sub> | propagation delay<br>$\bar{LE}$ to $\bar{Y}_n$     |                       | 55<br>20<br>16 | 190<br>38<br>32 |                | 240<br>48<br>41 |                | 285<br>57<br>48 | ns | 2.0<br>4.5<br>6.0 | Fig.7                  |           |
| t <sub>PHL</sub> / t <sub>PLH</sub> | propagation delay<br>$\bar{E}_1$ to $\bar{Y}_n$    |                       | 50<br>18<br>14 | 145<br>29<br>25 |                | 180<br>36<br>31 |                | 220<br>44<br>38 | ns | 2.0<br>4.5<br>6.0 | Fig.7                  |           |
| t <sub>PHL</sub> / t <sub>PLH</sub> | propagation delay<br>E <sub>2</sub> to $\bar{Y}_n$ |                       | 50<br>18<br>14 | 145<br>29<br>25 |                | 180<br>36<br>31 |                | 220<br>44<br>38 | ns | 2.0<br>4.5<br>6.0 | Fig.6                  |           |
| t <sub>THL</sub> / t <sub>TLH</sub> | output transition time                             |                       | 19<br>7<br>6   | 75<br>15<br>13  |                | 95<br>19<br>16  |                | 110<br>22<br>19 | ns | 2.0<br>4.5<br>6.0 | Fig.6                  |           |
| t <sub>w</sub>                      | $\bar{LE}$ pulse width<br>HIGH                     | 50<br>10<br>9         | 11<br>4<br>3   |                 | 65<br>13<br>11 |                 | 75<br>15<br>13 |                 | ns | 2.0<br>4.5<br>6.0 | Fig.8                  |           |
| t <sub>su</sub>                     | set-up time<br>A <sub>n</sub> to $\bar{LE}$        | 50<br>10<br>9         | 3<br>1<br>1    |                 | 65<br>13<br>11 |                 | 75<br>15<br>13 |                 | ns | 2.0<br>4.5<br>6.0 | Fig.8                  |           |
| t <sub>h</sub>                      | hold time<br>A <sub>n</sub> to $\bar{LE}$          | 30<br>6<br>5          | 3<br>1<br>1    |                 | 40<br>8<br>7   |                 | 45<br>9<br>8   |                 | ns | 2.0<br>4.5<br>6.0 | Fig.8                  |           |

# 3-to-8 line decoder/demultiplexer with address latches; inverting

74HC/HCT137

## DC CHARACTERISTICS FOR 74HCT

For the DC characteristics see *"74HC/HCT/HCU/HCMOS Logic Family Specifications"*.

Output capability: standard

I<sub>CC</sub> category: MSI

### Note to HCT types

The value of additional quiescent supply current ( $\Delta I_{CC}$ ) for a unit load of 1 is given in the family specifications. To determine  $\Delta I_{CC}$  per input, multiply this value by the unit load coefficient shown in the table below.

| INPUT            | UNIT LOAD COEFFICIENT |
|------------------|-----------------------|
| A <sub>n</sub>   | 1.50                  |
| $\overline{E}_1$ | 1.50                  |
| E <sub>2</sub>   | 1.50                  |
| $\overline{LE}$  | 1.50                  |

## AC CHARACTERISTICS FOR 74HCT

GND = 0 V; t<sub>r</sub> = t<sub>f</sub> = 6 ns; C<sub>L</sub> = 50 pF

| SYMBOL                              | PARAMETER   | T <sub>amb</sub> (°C) |      |      |            |      |             |      | UNIT | TEST CONDITIONS        |           |
|-------------------------------------|---|-----------------------|------|------|------------|------|-------------|------|------|------------------------|-----------|
|                                     |   | 74HCT                 |      |      |            |      |             |      |      | V <sub>CC</sub><br>(V) | WAVEFORMS |
|                                     |   | +25                   |      |      | -40 to +85 |      | -40 to +125 |      |      |                        |           |
|                                     |   | min.                  | typ. | max. | min.       | max. | min.        | max. |      |                        |           |
| t <sub>PHL</sub> / t <sub>PLH</sub> | propagation delay<br>A <sub>n</sub> to $\overline{Y}_n$   |                       | 22   | 38   |            | 48   |             | 57   | ns   | 4.5                    | Fig.6     |
| t <sub>PHL</sub> / t <sub>PLH</sub> | propagation delay<br>$\overline{LE}$ to $\overline{Y}_n$  |                       | 25   | 44   |            | 55   |             | 66   | ns   | 4.5                    | Fig.7     |
| t <sub>PHL</sub> / t <sub>PLH</sub> | propagation delay<br>$\overline{E}_1$ to $\overline{Y}_n$ |                       | 20   | 37   |            | 46   |             | 56   | ns   | 4.5                    | Fig.7     |
| t <sub>PHL</sub> / t <sub>PLH</sub> | propagation delay<br>E <sub>2</sub> to $\overline{Y}_n$   |                       | 18   | 35   |            | 44   |             | 53   | ns   | 4.5                    | Fig.6     |
| t <sub>THL</sub> / t <sub>TLH</sub> | output transition time                                    |                       | 7    | 15   |            | 19   |             | 22   | ns   | 4.5                    | Fig.6     |
| t <sub>w</sub>                      | $\overline{LE}$ pulse width<br>HIGH                       | 10                    | 5    |      | 13         |      | 15          |      | ns   | 4.5                    | Fig.8     |
| t <sub>su</sub>                     | set-up time<br>A <sub>n</sub> to $\overline{LE}$          | 10                    | 2    |      | 13         |      | 15          |      | ns   | 4.5                    | Fig.8     |
| t <sub>h</sub>                      | hold time<br>A <sub>n</sub> to $\overline{LE}$            | 7                     | 2    |      | 9          |      | 11          |      | ns   | 4.5                    | Fig.8     |

# 3-to-8 line decoder/demultiplexer with address latches; inverting

74HC/HCT137

## AC WAVEFORMS

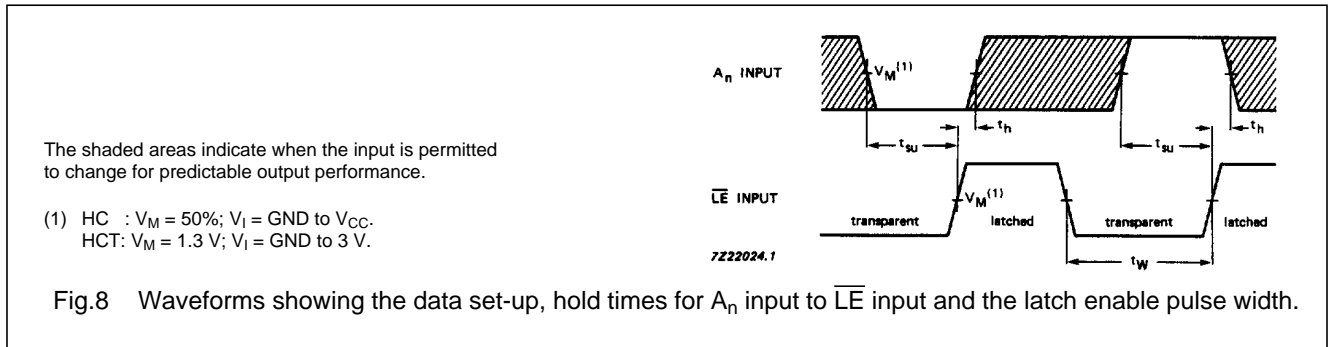
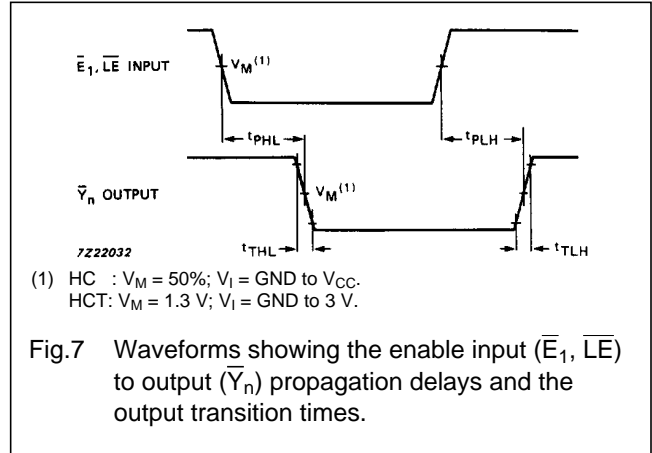
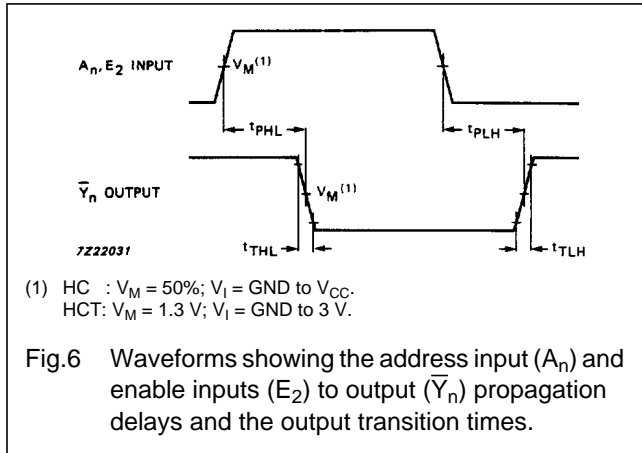

## APPLICATION INFORMATION

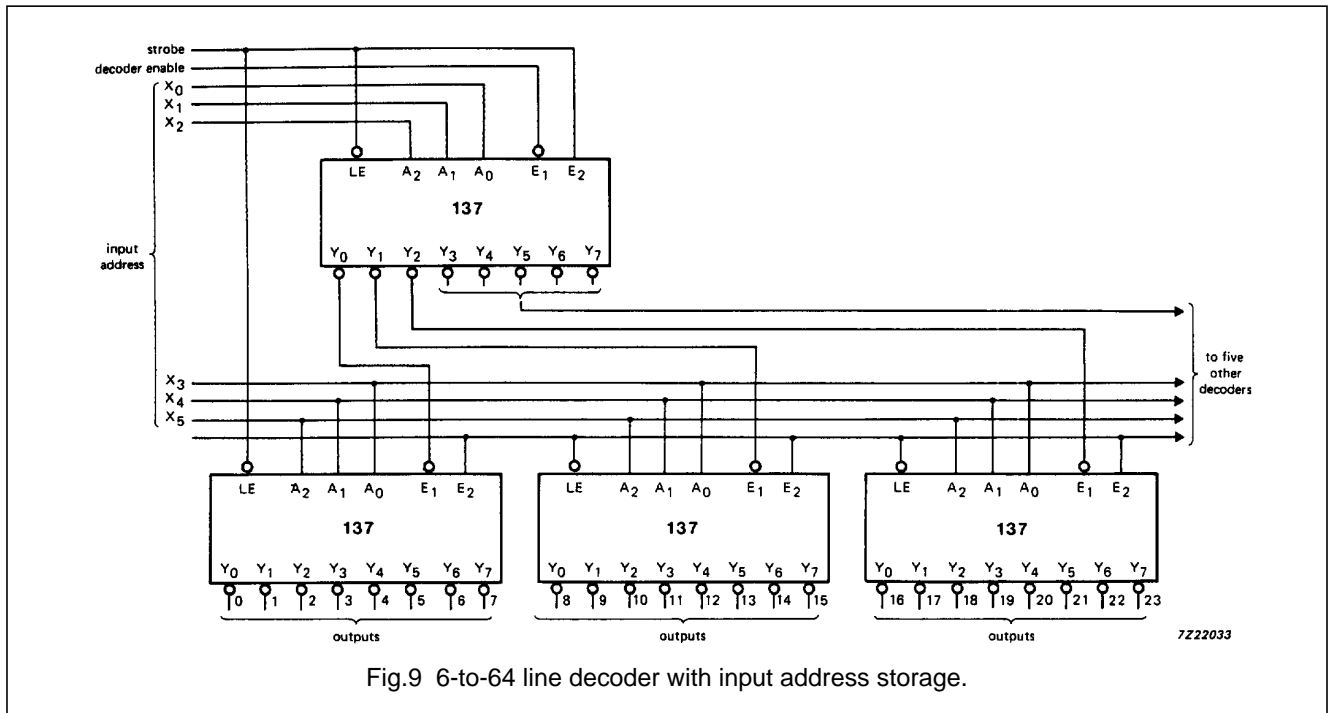

---

3-to-8 line decoder/demultiplexer with  
address latches; inverting

---

74HC/HCT137

**PACKAGE OUTLINES**

See *"74HC/HCT/HCU/HCMOS Logic Package Outlines"*.



LittleDiode supplies new, hard to find or obsolete electronic components and semiconductors all over the world.

With over two million different components listed you are sure to find the part you need.

Feel free to visit us today at our online store:

[LittleDiode.com](http://LittleDiode.com)

Looking forward to providing you with the best possible service.