

54AC/74AC138 • 54ACT/74ACT138 1-of-8 Decoder/Demultiplexer

General Description

The 'AC/'ACT138 is a high-speed 1-of-8 decoder/demultiplexer. This device is ideally suited for high-speed bipolar memory chip select address decoding. The multiple input enables allow parallel expansion to a 1-of-24 decoder using just three 'AC/'ACT138 devices or a 1-of-32 decoder using four 'AC/'ACT138 devices and one inverter.

Features

- I_{CC} reduced by 50%
- Demultiplexing capability
- Multiple input enable for easy expansion
- Active LOW mutually exclusive outputs
- Outputs source/sink 24 mA
- 'ACT138 has TTL-compatible inputs
- Standard Military Drawing (SMD)
 - 'AC138: 5962-87622
 - 'ACT138: 5962-87554

Logic Symbols

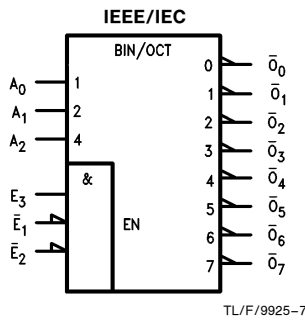
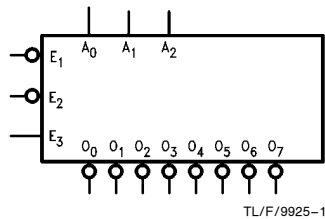

Connection Diagrams

Pin Assignment
for DIP, Flatpak and SOIC

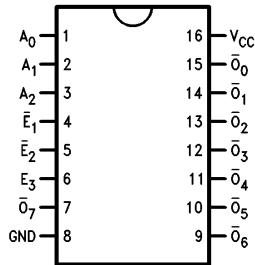

Pin Assignment
for LCC

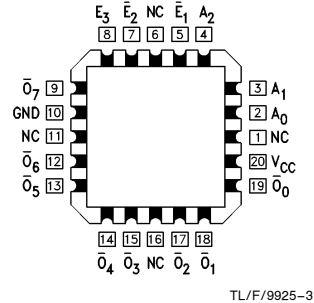

Pin Names	Description
A ₀ -A ₂	Address Inputs
\bar{E}_1 - \bar{E}_2	Enable Inputs
E ₃	Enable Input
\bar{O}_0 - \bar{O}_7	Outputs

FACT™ is a trademark of National Semiconductor Corporation.

Functional Description

The 'AC/'ACT138 high-speed 1-of-8 decoder/demultiplexer accepts three binary weighted inputs (A_0 , A_1 , A_2) and, when enabled, provides eight mutually exclusive active-LOW outputs (\bar{O}_0 – \bar{O}_7). The 'AC/'ACT138 features three Enable inputs, two active-LOW (\bar{E}_1 , \bar{E}_2) and one active-HIGH (E_3). All outputs will be HIGH unless \bar{E}_1 and \bar{E}_2 are LOW and E_3 is HIGH. This multiple enable function allows easy parallel expansion of the device to a 1-of-32 (5 lines to 32 lines)

decoder with just four 'AC/'ACT138 devices and one inverter (see *Figure 1*). The 'AC/'ACT138 can be used as an 8-output demultiplexer by using one of the active LOW Enable inputs as the data input and the other Enable inputs as strobes. The Enable inputs which are not used must be permanently tied to their appropriate active-HIGH or active-LOW state.

Truth Table

Inputs						Outputs							
\bar{E}_1	\bar{E}_2	E_3	A_0	A_1	A_2	\bar{O}_0	\bar{O}_1	\bar{O}_2	\bar{O}_3	\bar{O}_4	\bar{O}_5	\bar{O}_6	\bar{O}_7
H	X	X	X	X	X	H	H	H	H	H	H	H	H
X	H	X	X	X	X	H	H	H	H	H	H	H	H
X	X	L	X	X	X	H	H	H	H	H	H	H	H
L	L	H	L	L	L	L	H	H	H	H	H	H	H
L	L	H	H	L	L	L	H	L	H	H	H	H	H
L	L	H	L	H	L	H	H	L	H	H	H	H	H
L	L	H	H	H	L	H	H	H	L	H	H	H	H
L	L	H	L	L	H	H	H	H	H	L	H	H	H
L	L	H	H	L	H	H	H	H	H	H	L	H	H
L	L	H	L	H	H	H	H	H	H	H	H	L	H
L	L	H	H	H	H	H	H	H	H	H	H	H	L

H = HIGH Voltage Level
L = LOW Voltage Level
X = Immaterial

Logic Diagram

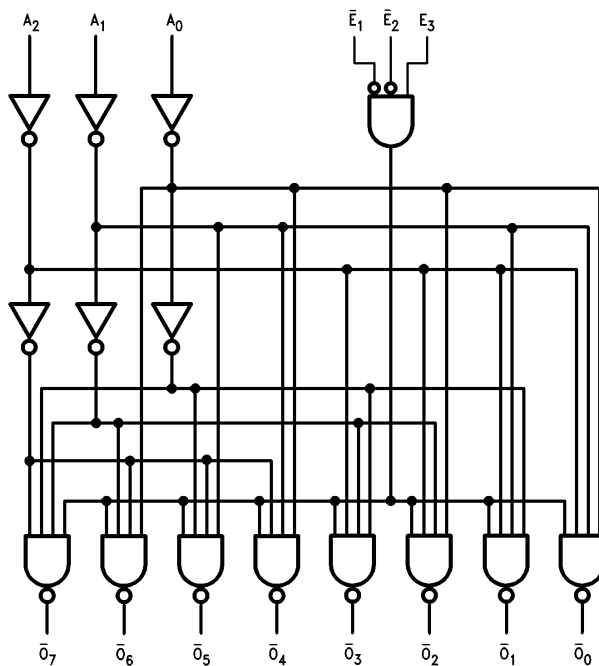

TL/F/9925-4

Please note that this diagram is provided only for the understanding of logic operations and should not be used to estimate propagation delays.

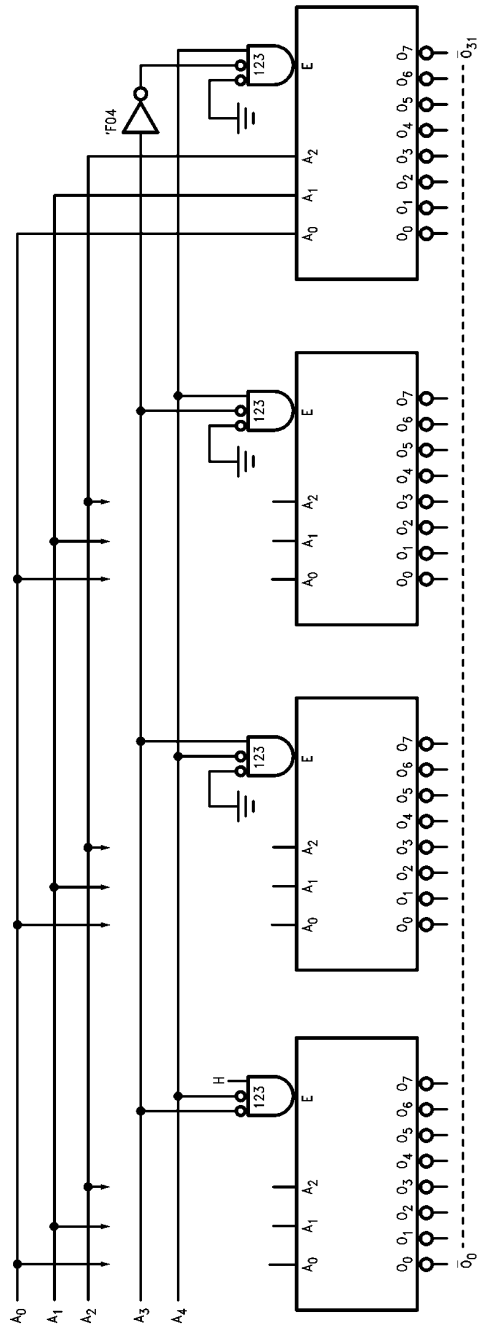

TL/F/9825-5

FIGURE 1. Expansion to 1-of-32 Decoding

Absolute Maximum Rating (Note 1)

If Military/Aerospace specified devices are required, please contact the National Semiconductor Sales Office/Distributors for availability and specifications.

Supply Voltage (V_{CC})	-0.5V to +7.0V
DC Input Diode Current (I_{IK})	
$V_I = -0.5V$	-20 mA
$V_I = V_{CC} + 0.5V$	+20 mA
DC Input Voltage (V_I)	-0.5V to $V_{CC} + 0.5V$
DC Output Diode Current (I_{OK})	
$V_O = -0.5V$	-20 mA
$V_O = V_{CC} + 0.5V$	+20 mA
DC Output Voltage (V_O)	-0.5V to $V_{CC} + 0.5V$
DC Output Source or Sink Current (I_O)	±50 mA
DC V_{CC} or Ground Current per Output Pin (I_{CC} or I_{GND})	±50 mA
Storage Temperature (T_{STG})	-65°C to +150°C
Junction Temperature (T_J)	
CDIP	175°C
PDIP	140°C

Note 1: Absolute maximum ratings are those values beyond which damage to the device may occur. The databook specifications should be met, without exception, to ensure that the system design is reliable over its power supply, temperature, and output/input loading variables. National does not recommend operation of FACT™ circuits outside databook specifications.

Recommended Operating Conditions

Supply Voltage (V_{CC})	2.0V to 6.0V
'AC	4.5V to 5.5V
'ACT	4.5V to 5.5V
Input Voltage (V_I)	0V to V_{CC}
Output Voltage (V_O)	0V to V_{CC}
Operating Temperature (T_A)	
74AC/ACT	-40°C to +85°C
54AC/ACT	-55°C to +125°C
Minimum Input Edge Rate ($\Delta V/\Delta t$)	
'AC Devices	
V_{IN} from 30% to 70% of V_{CC}	
V_{CC} @ 3.3V, 4.5V, 5.5V	125 mV/ns
Minimum Input Edge Rate ($\Delta V/\Delta t$)	
'ACT Devices	
V_{IN} from 0.8V to 2.0V	
V_{CC} @ 4.5V, 5.5V	125 mV/ns

DC Characteristics for 'AC Family Devices

Symbol	Parameter	V_{CC} (V)	74AC		54AC	74AC	Units	Conditions
			$T_A = +25^\circ\text{C}$		$T_A = -55^\circ\text{C to } +125^\circ\text{C}$	$T_A = -40^\circ\text{C to } +85^\circ\text{C}$		
			Typ	Guaranteed Limits				
V_{IH}	Minimum High Level Input Voltage	3.0	1.5	2.1	2.1	2.1	V	$V_{OUT} = 0.1V$ or $V_{CC} - 0.1V$
		4.5	2.25	3.15	3.15	3.15		
		5.5	2.75	3.85	3.85	3.85		
V_{IL}	Maximum Low Level Input Voltage	3.0	1.5	0.9	0.9	0.9	V	$V_{OUT} = 0.1V$ or $V_{CC} - 0.1V$
		4.5	2.25	1.35	1.35	1.35		
		5.5	2.75	1.65	1.65	1.65		
V_{OH}	Minimum High Level Output Voltage	3.0	2.99	2.9	2.9	2.9	V	$I_{OUT} = -50 \mu\text{A}$
		4.5	4.49	4.4	4.4	4.4		
		5.5	5.49	5.4	5.4	5.4		
V_{OL}	Maximum Low Level Output Voltage	3.0		2.56	2.4	2.46	V	* $V_{IN} = V_{IL}$ or V_{IH} -12 mA $I_{OH} -24 \text{ mA}$ -24 mA
		4.5		3.86	3.7	3.76		
		5.5		4.86	4.7	4.76		
V_{OL}	Maximum Low Level Output Voltage	3.0	0.002	0.1	0.1	0.1	V	$I_{OUT} = 50 \mu\text{A}$
		4.5	0.001	0.1	0.1	0.1		
		5.5	0.001	0.1	0.1	0.1		
V_{OL}	Maximum Low Level Output Voltage	3.0		0.36	0.50	0.44	V	* $V_{IN} = V_{IL}$ or V_{IH} 12 mA $I_{OL} 24 \text{ mA}$ 24 mA
		4.5		0.36	0.50	0.44		
		5.5		0.36	0.50	0.44		
I_{IN}	Maximum Input Leakage Current	5.5		±0.1	±1.0	±1.0	μA	$V_I = V_{CC}, \text{GND}$

*All outputs loaded; thresholds on input associated with output under test.

DC Characteristics for 'AC Family Devices (Continued)

Symbol	Parameter	V _{CC} (V)	74AC		54AC	74AC	Units	Conditions
			T _A = +25°C		T _A = -55°C to +125°C	T _A = -40°C to +85°C		
			Typ	Guaranteed Limits				
I _{OLD}	†Minimum Dynamic Output Current	5.5			50	75	mA	V _{OLD} = 1.65V Max
I _{OHD}		5.5			-50	-75	mA	V _{OHD} = 3.85V Min
I _{CC}	Maximum Quiescent Supply Current	5.5		4.0	80.0	40.0	μA	V _{IN} = V _{CC} or GND

†Maximum test duration 2.0 ms, one output loaded at a time.

Note: I_{IN} and I_{CC} @ 3.0V are guaranteed to be less than or equal to the respective limit @ 5.5V V_{CC}.

I_{CC} for 54AC @ 25°C is identical to 74AC @ 25°C.

DC Characteristics for 'ACT Family Devices

Symbol	Parameter	V _{CC} (V)	74ACT		54ACT	74ACT	Units	Conditions
			T _A = +25°C		T _A = -55°C to +125°C	T _A = -40°C to +85°C		
			Typ	Guaranteed Limits				
V _{IH}	Minimum High Level Input Voltage	4.5	1.5	2.0	2.0	2.0	V	V _{OUT} = 0.1V or V _{CC} - 0.1V
		5.5	1.5	2.0	2.0	2.0		
V _{IL}	Maximum Low Level Input Voltage	4.5	1.5	0.8	0.8	0.8	V	V _{OUT} = 0.1V or V _{CC} - 0.1V
		5.5	1.5	0.8	0.8	0.8		
V _{OH}	Minimum High Level Output Voltage	4.5	4.49	4.4	4.4	4.4	V	I _{OUT} = -50 μA
		5.5	5.49	5.4	5.4	5.4		
		4.5		3.86	3.70	3.76	V	*V _{IN} = V _{IL} or V _{IH} -24 mA I _{OH} -24 mA
		5.5		4.86	4.70	4.76		
V _{OL}	Maximum Low Level Output Voltage	4.5	0.001	0.1	0.1	0.1	V	I _{OUT} = 50 μA
		5.5	0.001	0.1	0.1	0.1		
		4.5		0.36	0.50	0.44	V	*V _{IN} = V _{IL} or V _{IH} 24 mA I _{OL} 24 mA
		5.5		0.36	0.50	0.44		
I _{IN}	Maximum Input Leakage Current	5.5		±0.1	±1.0	±1.0	μA	V _I = V _{CC} , GND
I _{CCT}	Maximum I _{CC} /Input	5.5	0.6		1.6	1.5	mA	V _I = V _{CC} - 2.1V
I _{OLD}	†Minimum Dynamic Output Current	5.5			50	75	mA	V _{OLD} = 1.65V Max
I _{OHD}		5.5			-50	-75	mA	V _{OHD} = 3.85V Min
I _{CC}	Maximum Quiescent Supply Current	5.5		4.0	80.0	40.0	μA	V _{IN} = V _{CC} or GND

*All outputs loaded; thresholds on input associated with output under test.

†Maximum test duration 2.0 ms, one output loaded at a time.

Note: I_{CC} for 54ACT @ 25°C is identical to 74ACT @ 25°C.

AC Electrical Characteristics

Symbol	Parameter	V _{CC} * (V)	74AC			54AC		74AC		Units
			T _A = +25°C C _L = 50 pF			T _A = -55°C to +125°C C _L = 50 pF		T _A = -40°C to +85°C C _L = 50 pF		
			Min	Typ	Max	Min	Max	Min	Max	
t _{PLH}	Propagation Delay A _n to \overline{O}_n	3.3 5.0	1.5 1.5	8.5 6.5	13.0 9.5	1.0 1.5	16.0 12.0	1.5 1.5	15.0 10.5	ns
t _{PHL}	Propagation Delay A _n to \overline{O}_n	3.3 5.0	1.5 1.5	8.0 6.0	12.5 9.0	1.0 1.5	15.0 11.5	1.5 1.5	14.0 10.5	ns
t _{PLH}	Propagation Delay \overline{E}_1 or \overline{E}_2 to \overline{O}_n	3.3 5.0	1.5 1.5	11.0 8.0	15.0 11.0	1.0 1.5	16.5 13.0	1.5 1.5	16.0 12.0	ns
t _{PHL}	Propagation Delay \overline{E}_1 or \overline{E}_2 to \overline{O}_n	3.3 5.0	1.5 1.5	9.5 7.0	13.5 9.5	1.0 1.5	15.5 12.0	1.5 1.5	15.0 10.5	ns
t _{PLH}	Propagation Delay E ₃ to \overline{O}_n	3.3 5.0	1.5 1.5	11.0 8.0	15.5 11.0	1.0 1.5	17.0 13.5	1.5 1.5	16.5 12.5	ns
t _{PHL}	Propagation Delay E ₃ to \overline{O}_n	3.3 5.0	1.5 1.5	8.5 6.0	13.0 8.0	1.0 1.5	15.0 11.0	1.5 1.0	14.0 9.5	ns

*Voltage Range 3.3 is 3.3V ±0.3V
Voltage Range 5.0 is 5.0V ±0.5V

AC Electrical Characteristics

Symbol	Parameter	V _{CC} * (V)	74ACT			54ACT		74ACT		Units
			T _A = +25°C C _L = 50 pF			T _A = -55°C to +125°C C _L = 50 pF		T _A = -40°C to +85°C C _L = 50 pF		
			Min	Typ	Max	Min	Max	Min	Max	
t _{PLH}	Propagation Delay A _n to \overline{O}_n	5.0	1.5	7.0	10.5	1.5	12.5	1.5	11.5	ns
t _{PHL}	Propagation Delay A _n to \overline{O}_n	5.0	1.5	6.5	10.5	1.5	12.5	1.5	11.5	ns
t _{PLH}	Propagation Delay \overline{E}_1 or \overline{E}_2 to \overline{O}_n	5.0	2.5	8.0	11.5	1.5	13.5	2.0	12.5	ns
t _{PHL}	Propagation Delay \overline{E}_1 or \overline{E}_2 to \overline{O}_n	5.0	2.0	7.5	11.5	1.5	12.5	2.0	12.5	ns
t _{PLH}	Propagation Delay E ₃ to \overline{O}_n	5.0	2.5	8.0	12.0	1.5	14.0	2.0	13.0	ns
t _{PHL}	Propagation Delay E ₃ to \overline{O}_n	5.0	2.0	6.5	10.5	1.5	12.0	1.5	11.5	ns

*Voltage Range 5.0 is 5.0V ±0.5V

Capacitance

Symbol	Parameter	Typ	Units	Conditions
C _{IN}	Input Capacitance	4.5	pF	V _{CC} = OPEN
C _{PD}	Power Dissipation Capacitance	60.0	pF	V _{CC} = 5.0V

Ordering Information

The device number is used to form part of a simplified purchasing code where the package type and temperature range are defined as follows:

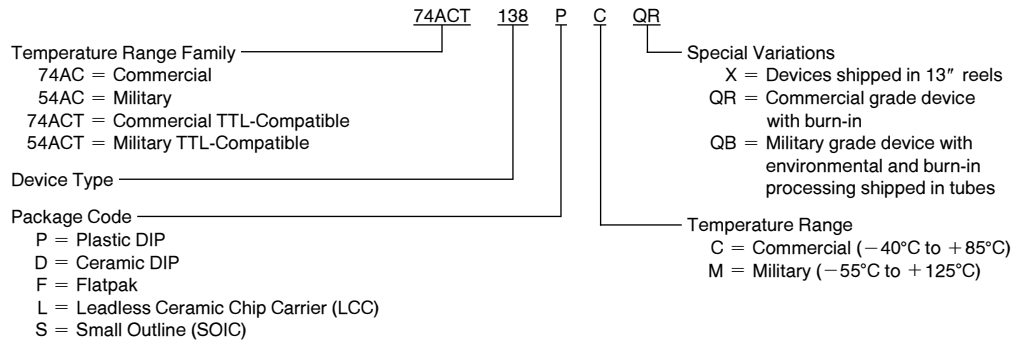

Physical Dimensions inches (millimeters) (Continued)

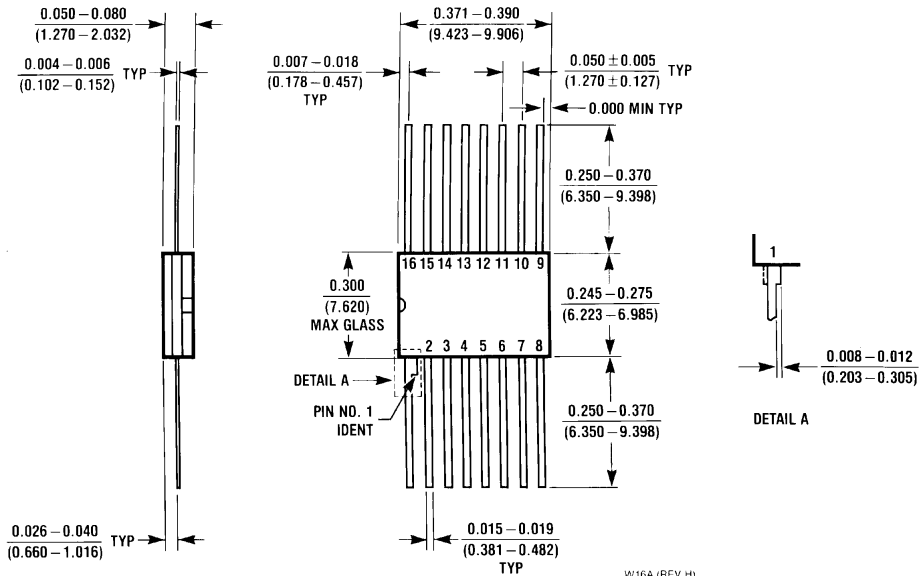

**16 Lead Ceramic Flatpak (F)
NS Package Number W16A**

W16A (REV H)

LIFE SUPPORT POLICY

NATIONAL'S PRODUCTS ARE NOT AUTHORIZED FOR USE AS CRITICAL COMPONENTS IN LIFE SUPPORT DEVICES OR SYSTEMS WITHOUT THE EXPRESS WRITTEN APPROVAL OF THE PRESIDENT OF NATIONAL SEMICONDUCTOR CORPORATION. As used herein:

1. Life support devices or systems are devices or systems which, (a) are intended for surgical implant into the body, or (b) support or sustain life, and whose failure to perform, when properly used in accordance with instructions for use provided in the labeling, can be reasonably expected to result in a significant injury to the user.
2. A critical component is any component of a life support device or system whose failure to perform can be reasonably expected to cause the failure of the life support device or system, or to affect its safety or effectiveness.



National Semiconductor Corporation
2900 Semiconductor Drive
P.O. Box 58090
Santa Clara, CA 95052-8090
Tel: (600) 272-9959
TWX: (910) 339-9240

National Semiconductor GmbH
Livry-Gargan-Str. 10
D-82256 Fürstenfeldbruck
Germany
Tel: (81-41) 35-0
Telex: 527849
Fax: (81-41) 35-1

National Semiconductor Japan Ltd.
Sumitomo Chemical
Engineering Center
Bldg. 7F
1-7-1, Nakase, Mihama-Ku
Chiba-City,
Ciba Prefecture 261
Tel: (043) 299-2300
Fax: (043) 299-2500

National Semiconductor Hong Kong Ltd.
13th Floor, Straight Block,
Ocean Centre, 5 Canton Rd.
Tsimshatsui, Kowloon
Hong Kong
Tel: (852) 2737-1600
Fax: (852) 2736-9960

National Semicondutores Do Brazil Ltda.
Rue Deputado Lacorda Franco
120-3A
Sao Paulo-SP
Brazil 05418-000
Tel: (55-11) 212-5066
Telex: 391-1131931 NSBR BR
Fax: (55-11) 212-1181

National Semiconductor (Australia) Pty. Ltd.
Building 16
Business Park Drive
Monash Business Park
Nottingham, Melbourne
Victoria 3168 Australia
Tel: (3) 558-9999
Fax: (3) 558-9998

National does not assume any responsibility for use of any circuitry described, no circuit patent licenses are implied and National reserves the right at any time without notice to change said circuitry and specifications.

National Semiconductor was acquired by Texas Instruments.

http://www.ti.com/corp/docs/investor_relations/pr_09_23_2011_national_semiconductor.html

This file is the datasheet for the following electronic components:

54ACT138 - <http://www.ti.com/product/54act138?HQS=TI-null-null-dscatalog-df-pf-null-ww>

54AC138 - <http://www.ti.com/product/54ac138?HQS=TI-null-null-dscatalog-df-pf-null-ww>

74AC138 - <http://www.ti.com/product/74ac138?HQS=TI-null-null-dscatalog-df-pf-null-ww>

74ACT138 - <http://www.ti.com/product/74act138?HQS=TI-null-null-dscatalog-df-pf-null-ww>



LittleDiode supplies new, hard to find or obsolete electronic components and semiconductors all over the world.

With over two million different components listed you are sure to find the part you need.

Feel free to visit us today at our online store:

LittleDiode.com

Looking forward to providing you with the best possible service.