

SN54LS295B, SN74LS295B 4-BIT RIGHT-SHIFT LEFT-SHIFT REGISTERS WITH 3-STATE OUTPUTS

SDLS154 - OCTOBER 1975 - REVISED MARCH 1988

- **'LS295B Offers Three Times the Sink-Current Capability of 'LS295A**
- **Schottky-Diode-Clamped Transistors**
- **Low Power Dissipation . . . 80 mW Typical (Enabled)**
- **Applications:**
 - N-Bit Serial-To-Parallel Converter**
 - N-Bit Parallel-To-Serial Converter**
 - N-Bit Storage Register**

description

These 4-bit registers feature parallel inputs, parallel outputs, and clock (CLK), serial (SER), mode (LD/SH), and outputs control (OC) inputs. The registers have three modes of operation:

- Parallel (broadside) load
- Shift right (the direction Q_A toward Q_D)
- Shift left (the direction Q_D toward Q_A)

Parallel loading is accomplished by applying the four bits of data and taking the mode control input high. The data is loaded into the associated flip-flops and appears at the outputs after the high-to-low transition of the clock input. During parallel loading, the entry of serial data is inhibited.

Shift right is accomplished when the mode control is low; shift left is accomplished when the mode control is high by connecting the output of each flip-flop to the parallel input of the previous flip-flop (Q_D to input C, etc.) and serial data is entered at input D.

When the output control is high, the normal logic levels of the four outputs are available for driving the loads or bus lines. The outputs are disabled independently from the level of the clock by a low logic level at the output control input. The outputs then present a high impedance and neither load nor drive the bus line; however, sequential operation of the registers is not affected.

The SN54LS295B is characterized for operation over the full military temperature range of -55°C to 125°C ; the SN74LS295B is characterized for operation from 0°C to 70°C .

SN54LS295B . . . J OR W PACKAGE
SN74LS295B . . . D OR N PACKAGE
(TOP VIEW)

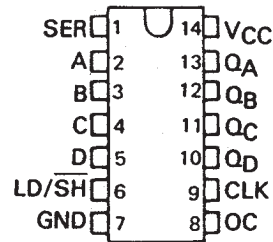

SN54LS295B . . . FK PACKAGE
(TOP VIEW)

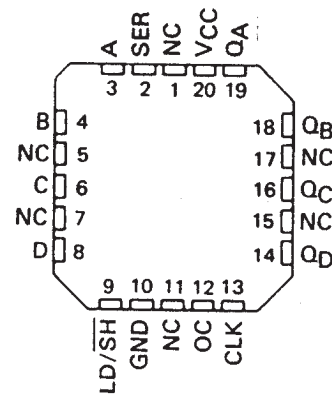

NC - No internal connection

logic symbol†

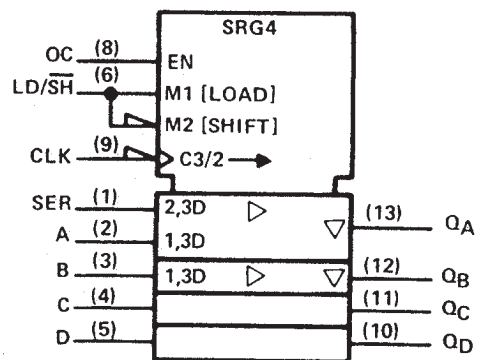

† This symbol is in accordance with ANSI/IEEE Std. 91-1984 and IEC Publication 617-12.

Pin numbers shown are for D, J, N, and W packages.

SN54LS295B, SN74LS295B 4-BIT RIGHT-SHIFT LEFT-SHIFT REGISTERS WITH 3-STATE OUTPUTS

SDLS154 – OCTOBER 1975 – REVISED MARCH 1988

logic diagram (positive logic)

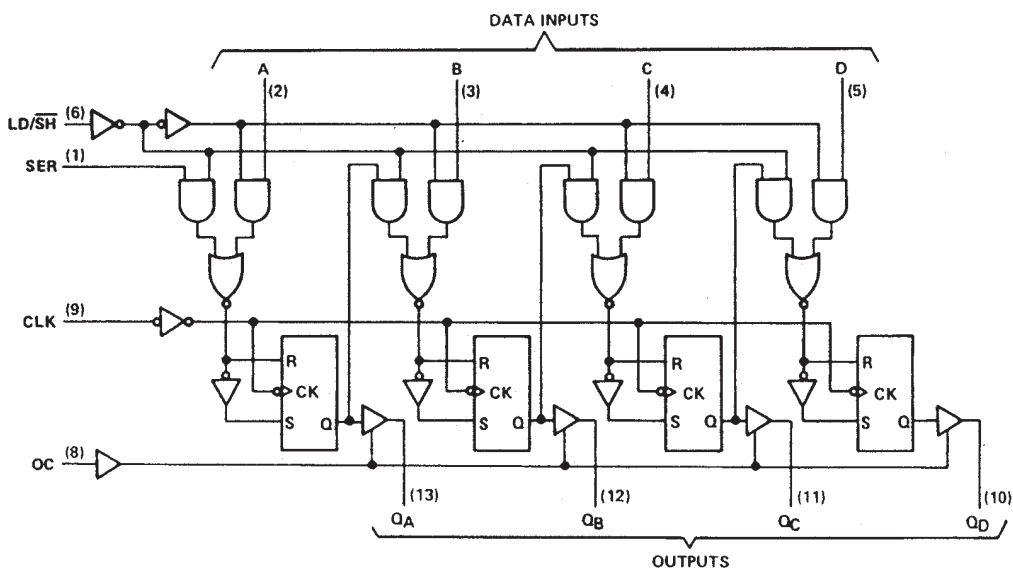

Pin numbers shown are for D, J, N, and W packages.

schematics of inputs and outputs

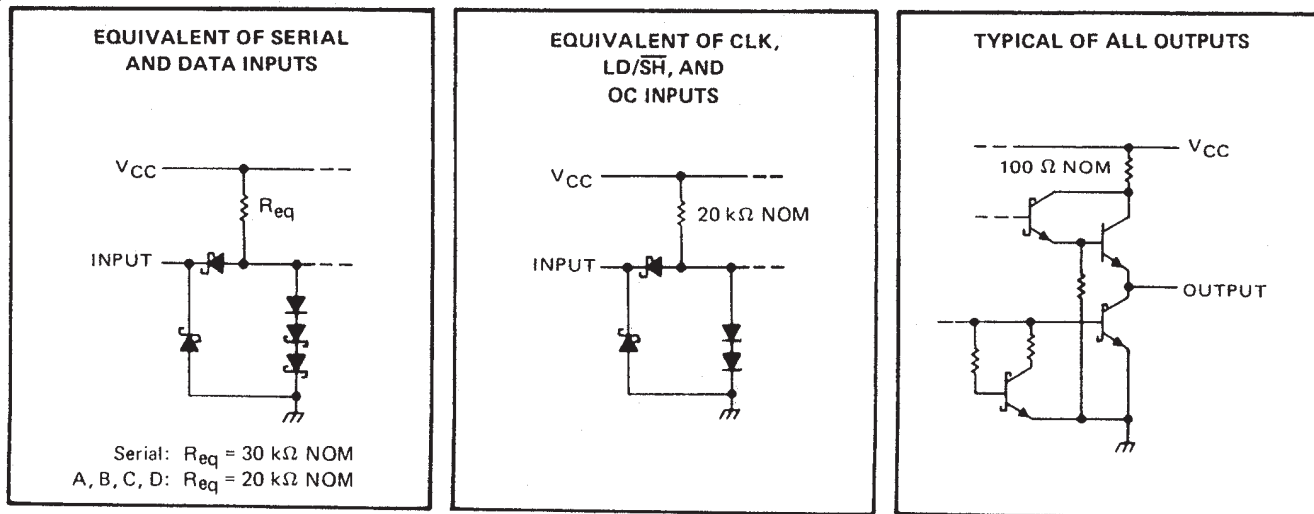

SN54LS295B, SN74LS295B 4-BIT RIGHT-SHIFT LEFT-SHIFT REGISTERS WITH 3-STATE OUTPUTS

SDLS154 – OCTOBER 1975 – REVISED MARCH 1988

FUNCTION TABLE

INPUTS		OUTPUTS								
		Q _A	Q _B	Q _C	Q _D					
LD/ \overline{SH}	CLK	SER	PARALLEL							
			A	B	C	D				
H	H	X	X	X	X	X	Q _{A0}	Q _{B0}	Q _{C0}	Q _{D0}
H	↓	X	a	b	c	d	a	b	c	d
H	↓	X	Q _B †	Q _C †	Q _D †	d	Q _{Bn}	Q _{Cn}	Q _{Dn}	d
L	H	X	X	X	X	X	Q _{A0}	Q _{B0}	Q _{C0}	Q _{D0}
L	↓	H	X	X	X	X	H	Q _{An}	Q _{Bn}	Q _{Cn}
L	↓	L	X	X	X	X	L	Q _{An}	Q _{Bn}	Q _{Cn}

When the output control is low, the outputs are disabled to the high-impedance state; however, sequential operation of the registers is not affected.

† Shifting left requires external connection of Q_B to A, Q_C to B, and Q_D to C. Serial data is entered at input D.

H = high level (steady state), L = low level (steady state), X = irrelevant (any input, including transitions)

↓ = transition from high to low level.

a, b, c, d = the level of steady-state input at inputs A, B, C, or D, respectively.

Q_{A0}, Q_{B0}, Q_{C0}, Q_{D0} = the level of Q_A, Q_B, Q_C, or Q_D, respectively, before the indicated steady-state input conditions were established.

Q_{An}, Q_{Bn}, Q_{Cn}, Q_{Dn} = the level of Q_A, Q_B, Q_C, or Q_D, respectively, before the most-recent ↓ transition of the clock.

absolute maximum ratings over operating free-air temperature range (unless otherwise noted)

Supply voltage, V _{CC} (see Note 1)	7 V
Input voltage	7 V
Operating free-air temperature range: SN54LS295B	-55°C to 125°C
SN74LS295B	0°C to 70°C
Storage temperature range	-65°C to 150°C

NOTE 1: Voltage values are with respect to network ground terminal.

recommended operating conditions

		SN54LS295B			SN74LS295B			UNIT
		MIN	NOM	MAX	MIN	NOM	MAX	
V _{CC}	Supply voltage	4.5	5	5.5	4.75	5	5.25	V
I _{OH}	High-level output current			-1			-2.6	mA
I _{OL}	Low-level output current			12			24	mA
f _{clock}	Clock frequency	0		30	0		30	MHz
t _{w(clock)}	Width of clock pulse	16			16			ns
t _{su}	Setup time, high-level or low-level data	20			20			ns
t _{su}	Setup time, LD/ \overline{SH} to CLK	high-level		25	25		ns	
		low-level		30	30			
t _h	Hold time, high-level or low-level data	20			20			ns
t _h	Hold time, high-level or low-level LD/ \overline{SH} to CLK	0			0			ns
T _A	Operating free-air temperature	-55		125	0		70	°C



SN54LS295B, SN74LS295B 4-BIT RIGHT-SHIFT LEFT-SHIFT REGISTERS WITH 3-STATE OUTPUTS

SDLS154 – OCTOBER 1975 – REVISED MARCH 1988

electrical characteristics over recommended operating free-air temperature range (unless otherwise noted)

PARAMETER	TEST CONDITIONS†	SN54LS295B			SN74LS295B			UNIT
		MIN	TYP‡	MAX	MIN	TYP‡	MAX	
V _{IH} High-level input voltage		2			2			V
V _{IL} Low-level input voltage				0.7			0.8	V
V _{IK} Input clamp voltage	V _{CC} = MIN, I _I = -18 mA			-1.5			-1.5	V
V _{OH} High-level output voltage	V _{CC} = MIN, V _{IH} = 2 V, V _{IL} = V _{IL max} , I _{OH} = MAX	2.4	3.4		2.4	3.1		V
V _{OL} Low-level output voltage	V _{CC} = MIN, V _{IH} = 2 V, V _{IL} = V _{IL max}	I _{OL} = 12 mA	0.25	0.4	0.25	0.4		V
		I _{OL} = 24 mA			0.35	0.5		
I _{OZH} Off-state output current, high-level voltage applied	V _{CC} = MAX, V _{IL} = V _{IL max} , V _O = 2.7 V			20			20	μA
I _{OZL} Off-state output current, low-level voltage applied	V _{CC} = MAX, V _{IH} = 2 V, V _O = 0.4 V			-20			-20	μA
I _I Input current at maximum input voltage	V _{CC} = MAX, V _I = 7 V			0.1			0.1	mA
I _{IH} High-level input current	V _{CC} = MAX, V _I = 2.7 V			20			20	μA
I _{IL} Low-level input current	V _{CC} = MAX, V _I = 0.4 V			-0.4			-0.4	mA
I _{OS} Short-circuit output current§	V _{CC} = MAX	-30		-130	-30		-130	mA
I _{CC} Supply current	V _{CC} = MAX, See Note 2	Condition A	20	29	20	29		mA
		Condition B	22	33	22	33		

† For conditions shown as MIN or MAX, use the appropriate value specified under recommended operating conditions.

‡ All typical values are at V_{CC} = 5 V, T_A = 25°C.

§ Not more than one output should be shorted at a time, and duration of the short-circuit should not exceed one second.

NOTE 2: I_{CC} is measured with the outputs open, the serial input and mode control at 4.5 V, and the data inputs grounded under the following conditions:

- A. Output control at 4.5 V and a momentary 3 V, then ground, applied to clock input.
- B. Output control and clock input grounded.

switching characteristics, V_{CC} = 5 V, T_A = 25°C, R_L = 667 Ω

PARAMETER	TEST CONDITIONS	MIN	TYP	MAX	UNIT
f _{max} Maximum clock frequency	C _L = 45 pF, See Note 3	30	45		MHz
t _{PLH} Propagation delay time, low-to-high-level output			14	20	ns
t _{PHL} Propagation delay time, high-to-low-level output			19	30	ns
t _{PZH} Output enable time to high level			18	26	ns
t _{PZL} Output enable time to low level			20	30	ns
t _{PHZ} Output disable time from high level	C _L = 5 pF, See Note 3		13	20	ns
t _{PLZ} Output disable time from low level			13	20	ns

NOTE 3: Load circuits and voltage waveforms are shown in Section 1.



IMPORTANT NOTICE

Texas Instruments and its subsidiaries (TI) reserve the right to make changes to their products or to discontinue any product or service without notice, and advise customers to obtain the latest version of relevant information to verify, before placing orders, that information being relied on is current and complete. All products are sold subject to the terms and conditions of sale supplied at the time of order acknowledgement, including those pertaining to warranty, patent infringement, and limitation of liability.

TI warrants performance of its semiconductor products to the specifications applicable at the time of sale in accordance with TI's standard warranty. Testing and other quality control techniques are utilized to the extent TI deems necessary to support this warranty. Specific testing of all parameters of each device is not necessarily performed, except those mandated by government requirements.

CERTAIN APPLICATIONS USING SEMICONDUCTOR PRODUCTS MAY INVOLVE POTENTIAL RISKS OF DEATH, PERSONAL INJURY, OR SEVERE PROPERTY OR ENVIRONMENTAL DAMAGE ("CRITICAL APPLICATIONS"). TI SEMICONDUCTOR PRODUCTS ARE NOT DESIGNED, AUTHORIZED, OR WARRANTED TO BE SUITABLE FOR USE IN LIFE-SUPPORT DEVICES OR SYSTEMS OR OTHER CRITICAL APPLICATIONS. INCLUSION OF TI PRODUCTS IN SUCH APPLICATIONS IS UNDERSTOOD TO BE FULLY AT THE CUSTOMER'S RISK.

In order to minimize risks associated with the customer's applications, adequate design and operating safeguards must be provided by the customer to minimize inherent or procedural hazards.

TI assumes no liability for applications assistance or customer product design. TI does not warrant or represent that any license, either express or implied, is granted under any patent right, copyright, mask work right, or other intellectual property right of TI covering or relating to any combination, machine, or process in which such semiconductor products or services might be or are used. TI's publication of information regarding any third party's products or services does not constitute TI's approval, warranty or endorsement thereof.

This datasheet has been downloaded from:

www.DatasheetCatalog.com

Datasheets for electronic components.

Texas Instruments

<http://www.ti.com>

This file is the datasheet for the following electronic components:

SN54LS295BJ - <http://www.ti.com/product/sn54ls295bj?HQS=TI-null-null-dscatalog-df-pf-null-ww>

74LS295 - <http://www.ti.com/product/74ls295?HQS=TI-null-null-dscatalog-df-pf-null-ww>

SN74LS295B - <http://www.ti.com/product/sn74ls295b?HQS=TI-null-null-dscatalog-df-pf-null-ww>

SN74LS295BD - <http://www.ti.com/product/sn74ls295bd?HQS=TI-null-null-dscatalog-df-pf-null-ww>

SN54LS295BFK - <http://www.ti.com/product/sn54ls295bfk?HQS=TI-null-null-dscatalog-df-pf-null-ww>

SN74LS295BN - <http://www.ti.com/product/sn74ls295bn?HQS=TI-null-null-dscatalog-df-pf-null-ww>

SN54LS295BW - <http://www.ti.com/product/sn54ls295bw?HQS=TI-null-null-dscatalog-df-pf-null-ww>

SN54LS295B - <http://www.ti.com/product/sn54ls295b?HQS=TI-null-null-dscatalog-df-pf-null-ww>



LittleDiode supplies new, hard to find or obsolete electronic components and semiconductors all over the world.

With over two million different components listed you are sure to find the part you need.

Feel free to visit us today at our online store:

LittleDiode.com

Looking forward to providing you with the best possible service.