

DATA SHEET

87C524/87C528

80C51 8-bit microcontrollers

16K/32K, 512 OTP, I²C, watchdog timer

Product specification

1999 Jul 23

Replaces data sheets 87C524 of 1998 May 01 and 87C528 of 1998 May 01
IC28 Data Handbook

80C51 8-bit microcontrollers

16K/32K, 512 OTP, I²C, watchdog timer

87C524/87C528

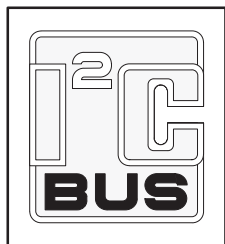

DESCRIPTION

The 87C528 single-chip 8-bit microcontroller is manufactured in an advanced CMOS process and is a derivative of the 80C51 microcontroller family. The 87C528 has the same instruction set as the 80C51. Three versions of the derivative exist:

- 83C528—32k bytes ROM
- 83C524—16k bytes ROM
- 80C528—ROMless version of the 83C528
- 87C528—32k bytes EPROM
- 83C524—16k bytes EPROM

This device provides architectural enhancements that make it applicable in a variety of applications in consumer, telecom and general control systems, especially in those systems which need large ROM and RAM capacity on-chip.

The 87C528 contains a 32k × 8 EPROM and the 87C524 contains a 16k × 8 EPROM. Both devices have a 512 × 8 RAM, four 8-bit I/O ports, two 16-bit timer/event counters (identical to the timers of the 80C51), a 16-bit timer (identical to the timer 2 of the 80C52), a watchdog timer with a separate oscillator, a multi-source, two-priority-level, nested interrupt structure, two serial interfaces (UART and I²C-bus), and on-chip oscillator and timing circuits.

In addition, the 87C524/87C528 has two software selectable modes of power reduction—idle mode and power-down mode. The idle mode freezes the CPU while allowing the RAM, timers, serial port, and interrupt system to continue functioning. The power-down mode saves the RAM contents but freezes the oscillator, causing all other chip functions to be inoperative.

FEATURES

- 80C51 instruction set
 - 512 × 8 RAM
 - Memory addressing capability 64k ROM and 64k RAM
 - Three 16-bit counter/timers
 - On-chip watchdog timer with oscillator
 - Full duplex UART
 - I²C serial interface
- Power control modes:
 - Idle mode
 - Power-down mode
 - Warm start from power-down
- CMOS and TTL compatible
- Extended temperature ranges
- EPROM code protection
- OTP package available
- 16 MHz speed at V_{CC} = 5 V

ORDERING INFORMATION

EPROM	TEMPERATURE °C RANGE AND PACKAGE	FREQ (MHz)	Drawing Number
P87C528EBP N	0 to +70, Plastic Dual In-line Package	16	SOT129-1
P87C528EBA A	0 to +70, Plastic Leaded Chip Carrier	16	SOT187-2
P87C528EBB B	0 to +70, Plastic Quad Flat Pack	16	SOT307-2
P87C528EFP N	–40 to +85, Plastic Dual In-line Package	16	SOT129-1
P87C528EFB B	–40 to +85, Plastic Quad Flat Pack	16	SOT307-2
P87C524EBA A	0 to +70, Plastic Leaded Chip Carrier	16	SOT187-2
P87C524EBB B	0 to +70, Plastic Quad Flat Pack	16	SOT307-2

NOTE:

1. For ROM & ROMless devices, see data sheet P8X524/528.

80C51 8-bit microcontrollers 16K/32K, 512 OTP, I²C, watchdog timer

87C524/87C528

BLOCK DIAGRAM

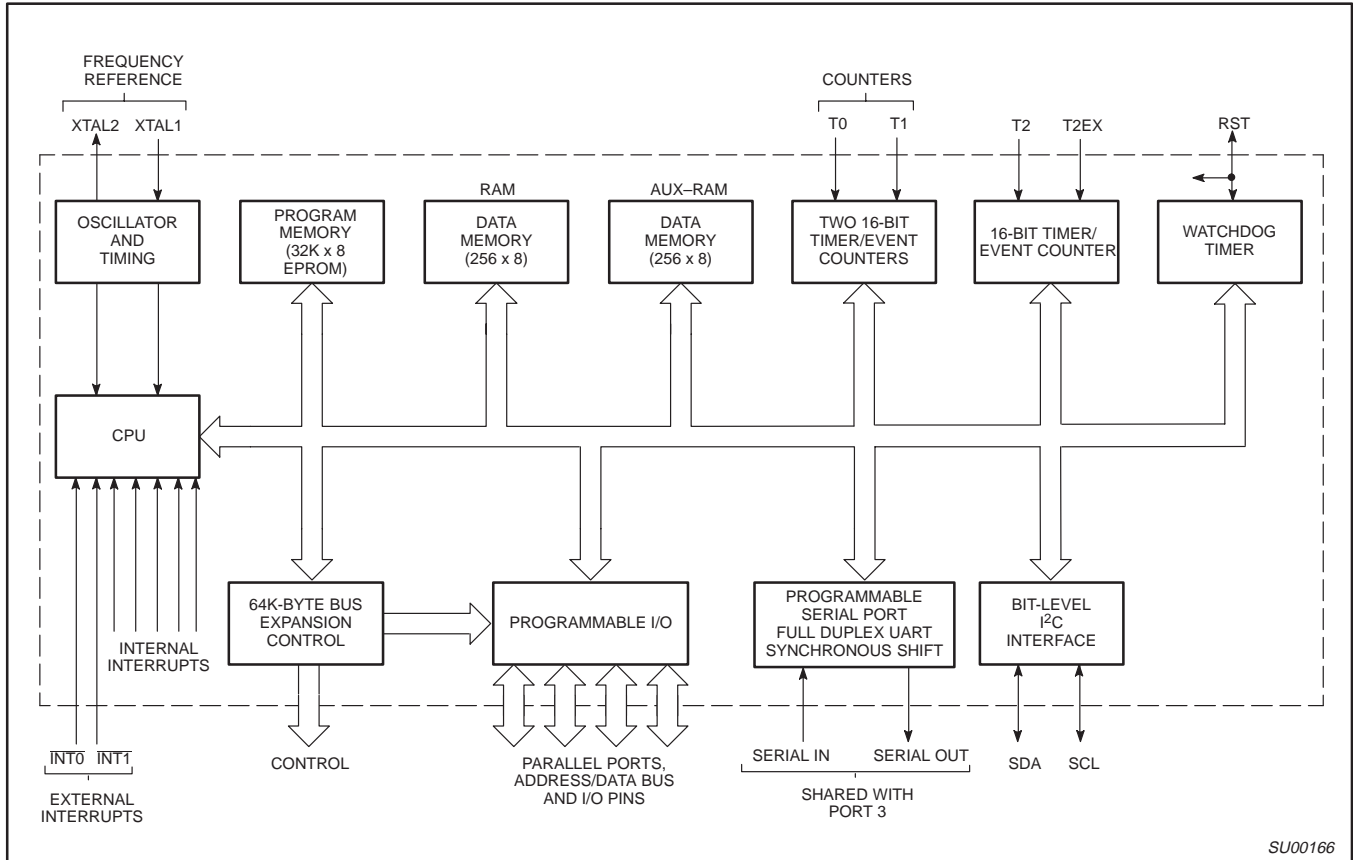

SU00166

LOGIC SYMBOL

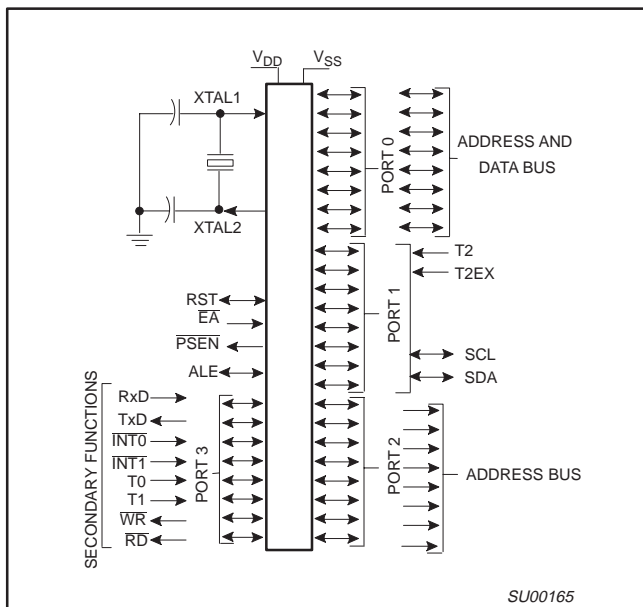

SU00165

80C51 8-bit microcontrollers 16K/32K, 512 OTP, I²C, watchdog timer

87C524/87C528

PIN CONFIGURATIONS

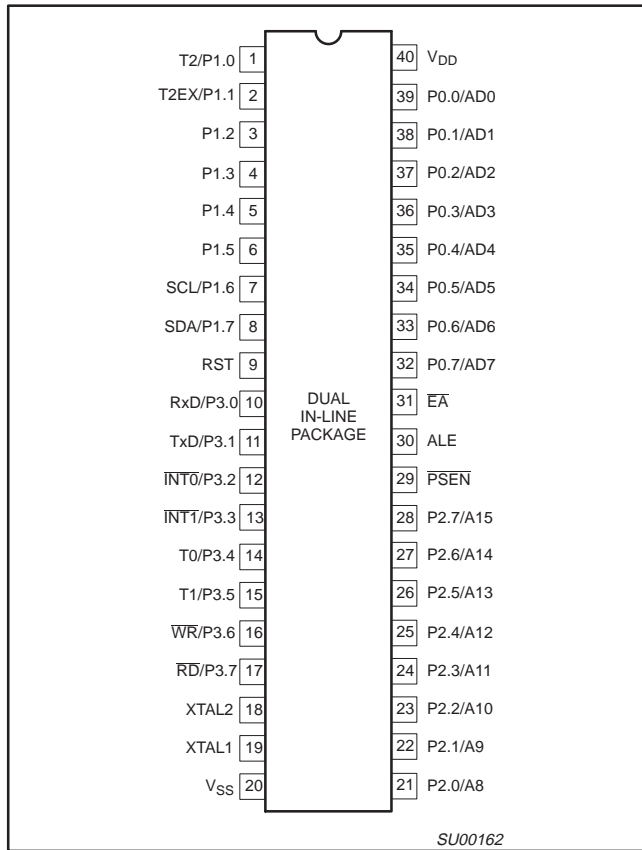

PLASTIC LEADED CHIP CARRIER PIN FUNCTIONS

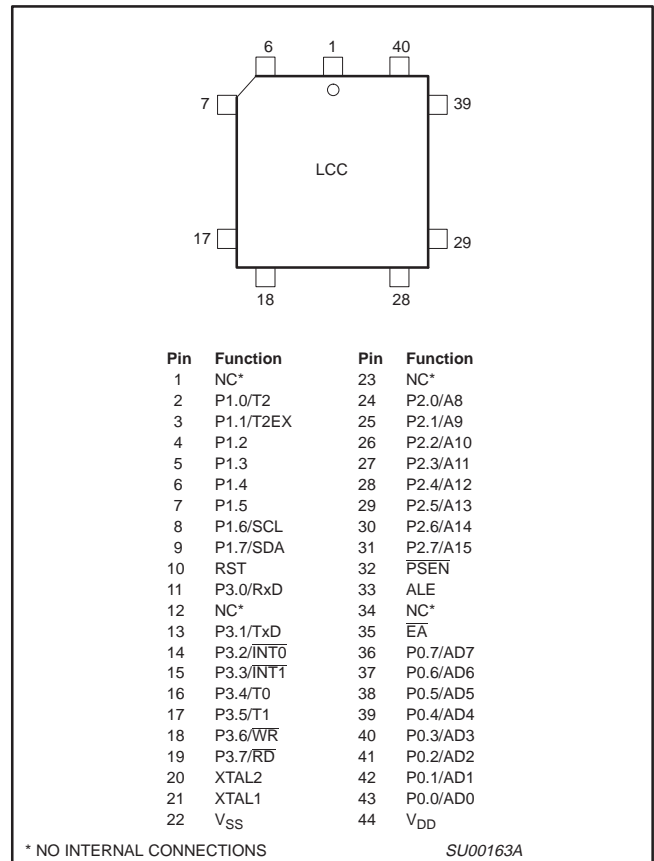

80C51 8-bit microcontrollers
 16K/32K, 512 OTP, I²C, watchdog timer

87C524/87C528

**PLASTIC QUAD FLAT PACK
 PIN FUNCTIONS**

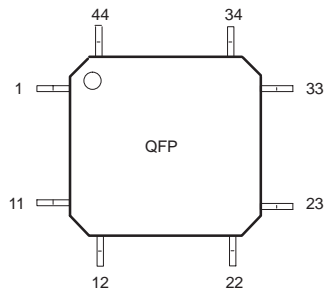

Pin	Function	Pin	Function
1	P1.5	23	P2.5/A13
2	P1.6/SCL	24	P2.6/A14
3	P1.7/SDA	25	P2.7/A15
4	RST	26	$\overline{\text{PSEN}}$
5	P3.0/RxD	27	ALE
6	NC*	28	NC*
7	P3.1/TxD	29	$\overline{\text{EA}}$
8	P3.2/INT0	30	P0.7/AD7
9	P3.3/INT1	31	P0.6/AD6
10	P3.4/T0	32	P0.5/AD5
11	P3.5/T1	33	P0.4/AD4
12	P3.6/ $\overline{\text{WR}}$	34	P0.3/AD3
13	P3.7/ $\overline{\text{RD}}$	35	P0.2/AD2
14	XTAL2	36	P0.1/AD1
15	XTAL1	37	P0.0/AD0
16	V _{SS}	38	V _{DD}
17	NC*	39	NC*
18	P2.0/A8	40	P1.0/T2
19	P2.1/A9	41	P1.1/T2EX
20	P2.2/A10	42	P1.2
21	P2.3/A11	43	P1.3
22	P2.4/A12	44	P1.4

* NO INTERNAL CONNECTIONS

SU00164

80C51 8-bit microcontrollers

16K/32K, 512 OTP, I²C, watchdog timer

87C524/87C528

PIN DESCRIPTIONS

MNEMONIC	PIN NO.			TYPE	NAME AND FUNCTION
	DIP	LCC	QFP		
V _{SS}	20	22	16	I	Ground: circuit ground potential.
V _{DD}	40	44	38	I	Power Supply: +5 V power supply pin during normal operation, Idle mode and Power-down mode.
P0.0–P0.7	39–32	43–36	37–30	I/O	Port 0: Port 0 is an open-drain, bidirectional I/O port. Port 0 pins that have 1s written to them float and can be used as high-impedance inputs. Port 0 is also the multiplexed low-order address and data bus during accesses to external program and data memory. In this application, it uses strong internal pull-ups when emitting 1s.
P1.0–P1.7	1–8	2–9	40–44 1–3	I/O	Port 1: Port 1 is an 8-bit bidirectional I/O port with internal pull-ups, except P1.6 and P1.7 which have open drain. Port 1 pins that have 1s written to them are pulled high by the internal pull-ups and can be used as inputs. As inputs, port 1 pins that are externally pulled low will source current because of the internal pull-ups. (See DC Electrical Characteristics: I _{IL}). Port 1 can sink/source one TTL (4 LSTTL) inputs. Port 1 receives the low-order address byte during program memory verification. Port 1 also serves alternate functions for timer 2:
	1	2	40	I	T2 (P1.0): Timer/counter 2 external count input (following edge triggered).
	2	3	41	I	T2EX (P1.1): Timer/counter 2 trigger input.
	7	8	2	I/O	SCL (P1.6): I ² C serial port clock line.
	8	9	3	I/O	SDA (P1.7): I ² C serial port data line.
P2.0–P2.7	21–28	24–31	18–25	I/O	Port 2: Port 2 is an 8-bit bidirectional I/O port with internal pull-ups. Port 2 pins that have 1s written to them are pulled high by the internal pull-ups and can be used as inputs. As inputs, port 2 pins that are externally being pulled low will source current because of the internal pull-ups. (See DC Electrical Characteristics: I _{IL}). Port 2 emits the high-order address byte during fetches from external program memory and during accesses to external data memory that use 16-bit addresses (MOVX @DPTR). In this application, it uses strong internal pull-ups when emitting 1s. During accesses to external data memory that use 8-bit addresses (MOV @Ri), port 2 emits the contents of the P2 special function register.
P3.0–P3.7	10–17	11, 13–19	5, 7–13	I/O	Port 3: Port 3 is an 8-bit bidirectional I/O port with internal pull-ups. Port 3 pins that have 1s written to them are pulled high by the internal pull-ups and can be used as inputs. As inputs, port 3 pins that are externally being pulled low will source current because of the pull-ups. (See DC Electrical Characteristics: I _{IL}). Port 3 also serves the special features of the SC80C51 family, as listed below:
	10	11	5	I	RxD (P3.0): Serial input port
	11	13	7	O	TxD (P3.1): Serial output port
	12	14	8	I	INT0 (P3.2): External interrupt
	13	15	9	I	INT1 (P3.3): External interrupt
	14	16	10	I	T0 (P3.4): Timer 0 external input
	15	17	11	I	T1 (P3.5): Timer 1 external input
	16	18	12	O	WR (P3.6): External data memory write strobe
	17	19	13	O	RD (P3.7): External data memory read strobe
RST	9	10	4	I/O	Reset: A high on this pin for two machine cycles while the oscillator is running, resets the device. An internal diffused resistor to V _{SS} permits a power-on reset using only an external capacitor to V _{DD} . After a watchdog timer overflow, this pin is pulled high while the internal reset signal is active.
ALE	30	33	27	I/O	Address Latch Enable: Output pulse for latching the low byte of the address during an access to external memory. In normal operation, ALE is emitted at a constant rate of 1/6 the oscillator frequency, and can be used for external timing or clocking. Note that one ALE pulse is skipped during each access to external data memory.
PSEN	29	32	26	O	Program Store Enable: The read strobe to external program memory. When the device is executing code from the external program memory, PSEN is activated twice each machine cycle, except that two PSEN activations are skipped during each access to external data memory. PSEN is not activated during fetches from internal program memory.
E _A	31	35	29	I	External Access Enable: E _A must be externally held low during RESET to enable the device to fetch code from external program memory locations 0000H to 7FFFH. If E _A is held high during RESET, the device executes from internal program memory unless the program counter contains an address greater than 7FFFH. E _A is don't care after RESET.
XTAL1	19	21	15	I	Crystal 1: Input to the inverting oscillator amplifier and input to the internal clock generator circuits.
XTAL2	18	20	14	O	Crystal 2: Output from the inverting oscillator amplifier.

80C51 8-bit microcontrollers
16K/32K, 512 OTP, I²C, watchdog timer

87C524/87C528

Table 1. 8XC524/8XC528 Special Function Registers

SYMBOL	DESCRIPTION	DIRECT ADDRESS	BIT ADDRESS, SYMBOL, OR ALTERNATIVE PORT FUNCTION								RESET VALUE
			MSB				LSB				
ACC*	Accumulator	E0H	E7	E6	E5	E4	E3	E2	E1	E0	00H
B*	B register	F0H	F7	F6	F5	F4	F3	F2	F1	F0	00H
DPTR: DPH DPL	Data pointer (2 bytes): Data pointer high Data pointer low	83H									00H
		82H									00H
IE*#	Interrupt enable	A8H	AF	AE	AD	AC	AB	AA	A9	A8	00H
			EA	ES1	ET2	ES0	ET1	EX1	ET0	EX0	
IP*#	Interrupt priority	B8H	BF	BE	BD	BC	BB	BA	B9	B8	x0000000B
			–	PS1	PT2	PS0	PT1	PX1	PT0	PX0	
P0*	Port 0	80H	87	86	85	84	83	82	81	80	FFH
			AD7	AD6	AD5	AD4	AD3	AD2	AD1	AD0	
P1*	Port 1	90H	97	96	95	94	93	92	91	90	FFH
			SDA	SEL	–	–	–	–	T2EX	T2	
P2*	Port 2	A0H	A7	A6	A5	A4	A3	A2	A1	A0	FFH
			A15	A14	A13	A12	A11	A10	A9	A8	
P3*	Port 3	B0H	B7	B6	B5	B4	B3	B2	B1	B0	FFH
			RD	WR	T1	T0	INT1	INT0	TxD	RxD	
PCON	Power control	87H	SMOD	–	–	–	GF1	GF0	PD	IDL	0xxx0000B
			D7	D6	D5	D4	D3	D2	D1	D0	
PSW*	Program status word	D0H	CY	AC	F0	RS1	RS0	OV	F1	P	00H
RCAP2H# RCAP2L# SBUF	Capture high Capture low Serial data buffer	CBH									00H
		CAH									00H
SBUF	Serial data buffer	99H									xxxxxxx0B
		9F	9E	9D	9C	9B	9A	99	98		
SCON*	Serial controller	98H	SM0	SM1	SM2	REN	TB8	RB8	TI	RI	00H
S1BIT#	Serial I ² C data	D9H/RD	SDI	0	0	0	0	0	0	0	x0000000B
		WR	SD0	X	X	X	X	X	X	X	0xxxxxxx0B
S1INT#	Serial I ² C interrupt	DAH	INT	X	X	X	X	X	X	X	0xxxxxxx0B
		DF	DE	DD	DC	DB	DA	D9	D8		
S1SCS*#	Serial I ² C control	D8H/RD	SDI	SCI	CLH	BB	RBF	WBF	STR	ENS	xxxx0000B
		WR	SD0	SC0	CLH	X	X	X	STR	ENS	00xxxx00B
SP	Stack pointer	81H									07H
TCON*	Timer control	88H	8F	8E	8D	8C	8B	8A	89	88	00H
			TF1	TR1	TF0	TR0	IE1	IT1	IE0	IT0	
T2CON*#	Timer 2 control	C8H	CF	CE	CD	CC	CB	CA	C9	C8	00H
			TF2	EXF2	RCLK	TCLK	EXEN2	TR2	C/T2	CP/RL2	
TH0	Timer high 0	8CH									00H
TH1	Timer high 1	8DH									00H
TH2#	Timer high 2	CDH									00H
TL0	Timer low 0	8AH									00H
TL1	Timer low 1	8BH									00H
TL2#	Timer low 2	CCH									00H
T3#	Watchdog timer	FFH									00H
TMOD	Timer mode	89H	GATE	C/T	M1	M0	GATE	C/T	M1	M0	00H
WDCON#	Watchdog control	A5H									A5H

* SFRs are bit addressable.

SFRs are modified from or added to the 80C51 SFRs.

80C51 8-bit microcontrollers

16K/32K, 512 OTP, I²C, watchdog timer

87C524/87C528

Table 2. Internal and External Program Memory Access with Security Bit Set

INSTRUCTION	ACCESS TO INTERNAL PROGRAM MEMORY	ACCESS TO EXTERNAL PROGRAM MEMORY
MOVC in internal program memory	YES	YES
MOVC in external program memory	NO	YES

INTERNAL DATA MEMORY

The internal data memory is divided into three physically separated segments: 256 bytes of RAM, 256 bytes of AUX-RAM, and a 128 bytes special function area. These can be addressed each in a different way.

- RAM 0 to 127 can be addressed directly and indirectly as in the 80C51. Address pointers are R0 and R1 of the selected register bank.
- RAM 128 to 255 can only be addressed indirectly as in the 80C51. Address pointers are R0 and R1 of the selected register bank.
- AUX-RAM 0 to 255 is indirectly addressed in the same way as external data memory with the MOVX instructions. Address pointers are R0, R1 of the selected register bank and DPTR. An access to AUX-RAM 0 to 255 will not affect ports P0, P2, P3.6 and P3.7.

An access to external data memory locations higher than 255 will be performed with the MOVX DPTR instructions in the same way as in the 8051 structure, so with P0 and P2 as data/address bus and P3.6 and P3.7 as write and read timing signals. Note that these external data memory cannot be accessed with R0 and R1 as address pointer.

TIMER 2

Timer 2 is functionally equal to the Timer 2 of the 8052AH. Timer 2 is a 16-bit timer/counter. These 16 bits are formed by two special function registers TL2 and TH2. Another pair of special function register RCAP2L and RCAP2H form a 16-bit capture register or a 16-bit reload register. Like Timer 0 and 1, it can operate either as a timer or as an event counter. This is selected by bit C/T2N in the special function register T2CON. It has three operating modes: capture, autoloader, and baud rate generator mode which are selected by bits in T2CON.

WATCHDOG TIMER T3

The watchdog timer consists of an 11-bit prescaler and an 8-bit timer formed by special function register T3. The prescaler is incremented by an on-chip oscillator with a fixed frequency of 1MHz. The maximum tolerance on this frequency is –50% and +100%. The 8-bit timer increments every 2048 cycles of the on-chip oscillator. When a timer overflow occurs, the microcontroller is reset and a reset output pulse of 16×2048 cycles of the on-chip oscillator is generated at pin RST. The internal RESET signal is not inhibited when the external RST pin is kept low by, for example, an external reset circuit. The RESET signal drives port 1, 2, 3 into the high state and port 0 into the high impedance state.

The watchdog timer is controlled by one special function register WDCON with the direct address location A5H. WDCON can be read and written by software. A value of A5H in WDCON halts the on-chip oscillator and clears both the prescaler and timer T3. After the RESET signal, WDCON contains A5H. Every value other than A5H in WDCON enables the watchdog timer. When the watchdog timer is enabled, it runs independently of the XTAL-clock.

Timer T3 can be read on the fly. Timer T3 can only be written if WDCON contains the value 5AH. A successful write operation to T3 will clear the prescaler and WDCON, leaving the watchdog enabled and preventing inadvertent changes of T3. To prevent an overflow of

the watchdog timer, the user program has to reload the watchdog timer within periods that are shorter than the programmed watchdog timer interval. This time interval is determined by an 8-bit value that has to be loaded in register T3 while at the same time the prescaler is cleared by hardware.

$$\text{Watchdog timer interval} = \frac{[256 - (T3)] \times 2048}{\text{on-chip oscillator frequency}}$$

BIT-LEVEL I²C INTERFACE

This bit-level serial I/O interface supports the I²C-bus. P1.6/SCL and P1.7/SDA are the serial I/O pins. These two pins meet the I²C specification concerning the input levels and output drive capability. Consequently, these pins have an open drain output configuration. All the four modes of the I²C-bus are supported:

- master transmitter
- master receiver
- slave transmitter
- slave receiver

The advantages of the bit-level I²C hardware compared with a full software I²C implementation are:

- the hardware can generate the SCL pulse
- Testing a single bit (RBF respectively, WBF) is sufficient as a check for error free transmission.

The bit-level I²C hardware operates on serial bit level and performs the following functions:

- filtering the incoming serial data and clock signals
- recognizing the START condition
- generating a serial interrupt request SI after reception of a START condition and the first falling edge of the serial clock
- recognizing the STOP condition
- recognizing a serial clock pulse on the SCL line
- latching a serial bit on the SDA line (SDI)
- stretching the SCL LOW period of the serial clock to suspend the transfer of the next serial data bit
- setting Read Bit Finished (RBF) when the SCL clock pulse has finished and Write Bit Finished (WBF) if there is no arbitration loss detected (i.e., SDA = 0 while SDO = 1)
- setting a serial clock Low-to-High detected (CLH) flag
- setting a Bus Busy (BB) flag on a START condition and clearing this flag on a STOP condition
- releasing the SCL line and clearing the CLH, RBF and WBF flags to resume transfer of the next serial data bit
- generating an automatic clock if the single bit data register S1BIT is used in master mode.

The following functions must be done in software:

- handling the I²C START interrupts
- converting serial to parallel data when receiving
- converting parallel to serial data when transmitting
- comparing the received slave address with its own
- interpreting the acknowledge information
- guarding the I²C status if RBF or WBF = 0.

80C51 8-bit microcontrollers

16K/32K, 512 OTP, I²C, watchdog timer

87C524/87C528

Additionally, if acting as master:

- generating START and STOP conditions
- handling bus arbitration
- generating serial clock pulses if S1BIT is not used.

Three SFRs control the bit-level I²C interface: S1INT, S1BIT and S1SCS.

INTERRUPT SYSTEM

The interrupt structure of the 8XC528 is the same as that used in the 80C51, but includes two additional interrupt sources: one for the third timer/counter, T2, and one for the I²C interface. The interrupt enable and interrupt priority registers are IE and IP.

IE: Interrupt Enable Register

This register is located at address A8H. Refer to Table 3.

IE SFR (A8H)

7	6	5	4	3	2	1	0
EA	ES1	ET2	ES	ET1	EX1	ET0	EX0

IP: Interrupt Priority Register

This register is located at address B8H. Refer to Table 4.

IP SFR (B8H)

7	6	5	4	3	2	1	0
-	PS1	PT2	PS	PT1	PX1	PT0	PX0

Table 3. Description of IE Bits

MNEMONIC	BIT	FUNCTION
EA	IE.7	General enable/disable control: 0 = NO interrupt is enabled. 1 = ANY individually enabled interrupt will be accepted.
ES1	IE.6	Enable bit-level I²C I/O interrupt
ET2	IE.5	Enable Timer 2 interrupt
ES	IE.4	Enable Serial Port interrupt
ET1	IE.3	Enable Timer 1 interrupt
EX1	IE.2	Enable External interrupt 1
ET0	IE.1	Enable Timer 0 interrupt
EX0	IE.0	Enable External interrupt 0

Table 4. Description of IP Bits

MNEMONIC	BIT	FUNCTION
-	IP.7	Reserved.
PS1	IP.6	Bit-level I²C interrupt priority level
PT2	IP.5	Timer 2 interrupt priority level
PS	IP.4	Serial Port interrupt priority level
PT1	IP.3	Timer 1 interrupt priority level
PX1	IP.2	External Interrupt 1 priority level
PT0	IP.1	Timer 0 interrupt priority level
PX0	IP.0	External Interrupt 0 priority level

The interrupt vector locations and the interrupt priorities are:

Source	Priority within Level
Vector Address	
0003H IE0	Highest
002BH TF2+EXF2	
0053H SI (I ² C)	
000BH TF0	
0013H IE1	
001BH TF1	
0023H RI+TI	Lowest

80C51 8-bit microcontrollers 16K/32K, 512 OTP, I²C, watchdog timer

87C524/87C528

OSCILLATOR CHARACTERISTICS

XTAL1 and XTAL2 are the input and output, respectively, of an inverting amplifier. The pins can be configured for use as an on-chip oscillator, as shown in the Logic Symbol.

To drive the device from an external clock source, XTAL1 should be driven while XTAL2 is left unconnected. There are no requirements on the duty cycle of the external clock signal, because the input to the internal clock circuitry is through a divide-by-two flip-flop. However, minimum and maximum high and low times specified in the data sheet must be observed.

RESET

A reset is accomplished by holding the RST pin high for at least two machine cycles (24 oscillator periods), while the oscillator is running. To insure a good power-up reset, the RST pin must be high long enough to allow the oscillator time to start up (normally a few milliseconds) plus two machine cycles. At power-up, the voltage on V_{DD} and RST must come up at the same time for a proper start-up.

IDLE MODE

In idle mode, the CPU puts itself to sleep while all of the on-chip peripherals stay active. The instruction to invoke the idle mode is the last instruction executed in the normal operating mode before the idle mode is activated. The CPU contents, the on-chip RAM, and all of the special function registers remain intact during this mode. The idle mode can be terminated either by any enabled interrupt (at which time the process is picked up at the interrupt service routine and continued), or by a hardware reset which starts the processor in the same manner as a power-on reset.

POWER-DOWN MODE

In the power-down mode, the oscillator is stopped and the instruction to invoke power-down is the last instruction executed. The power-down mode can be terminated by a RESET in the same way as in the 80C51 or in addition by one of two external interrupts, INT0 or INT1. A termination with an external interrupt does not affect the internal data memory and does not affect the special function registers. This makes it possible to exit power-down without changing the port output levels. To terminate the power-down mode with an external interrupt INT0 or INT1 must be switched to level-sensitive and must be enabled. The external interrupt input signal INT0 and INT1 must be kept low until the oscillator has restarted and stabilized. An instruction following the instruction that puts the device in the power-down mode will be executed. A reset generated by the watchdog timer terminates the power-down mode in the same way as an external RESET, and only the contents of the on-chip RAM are preserved. The control bits for the reduced power modes are in the special function register PCON.

DESIGN CONSIDERATIONS

At power-on, the voltage on V_{DD} and RST must come up at the same time for a proper start-up.

When the idle mode is terminated by a hardware reset, the device normally resumes program execution, from where it left off, up to two machine cycles before the internal reset algorithm takes control. On-chip hardware inhibits access to internal RAM in this event, but access to the port pins is not inhibited. To eliminate the possibility of an unexpected write when idle is terminated by reset, the instruction following the one that invokes idle should not be one that writes to a port pin or to external memory.

Table 5 shows the state of I/O ports during low current operating modes.

Table 5. External Pin Status During Idle and Power-Down Modes

MODE	PROGRAM MEMORY	ALE	PSEN	PORT 0	PORT 1	PORT 2	PORT 3
Idle	Internal	1	1	Data	Data	Data	Data
Idle	External	1	1	Float	Data	Address	Data
Power-down	Internal	0	0	Data	Data	Data	Data
Power-down	External	0	0	Float	Data	Data	Data

ABSOLUTE MAXIMUM RATINGS^{1, 2, 3}

PARAMETER	RATING	UNIT
Operating temperature under bias	0 to +70, or -40 to +85	°C
Storage temperature range	-65 to +150	°C
Voltage on any other pin to V _{SS}	-0.5 to V _{DD} +0.5	V
Input, output current on any two pins	±10	mA
Power dissipation (based on package heat transfer limitations, not device power consumption)	1.0	W

NOTES:

- Stresses above those listed under Absolute Maximum Ratings may cause permanent damage to the device. This is a stress rating only and functional operation of the device at these or any conditions other than those described in the AC and DC Electrical Characteristics section of this specification is not implied.
- This product includes circuitry specifically designed for the protection of its internal devices from the damaging effects of excessive static charge. Nonetheless, it is suggested that conventional precautions be taken to avoid applying greater than the rated maxima.
- Parameters are valid over operating temperature range unless otherwise specified. All voltages are with respect to V_{SS} unless otherwise noted.

80C51 8-bit microcontrollers

16K/32K, 512 OTP, I²C, watchdog timer

87C524/87C528

DC ELECTRICAL CHARACTERISTICS

 $T_{amb} = 0^{\circ}\text{C to } +70^{\circ}\text{C}$ ($V_{DD} = 5\text{ V} \pm 10\%$), $-40^{\circ}\text{C to } +85^{\circ}\text{C}$ ($V_{DD} = 5\text{ V} \pm 10\%$), $V_{SS} = 0\text{ V}$

SYMBOL	PARAMETER	PART TYPE	TEST CONDITIONS	LIMITS		UNIT
				MIN	MAX	
V _{IL}	Input low voltage, except $\overline{\text{EA}}$, P1.6/SCL, P1.7/SDA	0°C to 70°C -40°C to +85°C		-0.5	0.2V _{CC} -0.1	V
				-0.5	0.2V _{CC} -0.15	V
V _{IL1}	Input low voltage to $\overline{\text{EA}}$	0°C to 70°C -40°C to +85°C		0	0.2V _{CC} -0.3	V
				0	0.2V _{CC} -0.35	V
V _{IL2}	Input low voltage to P1.6/SCL, P1.7/SDA ⁵			-0.5	0.3 V	V
V _{IH}	Input high voltage, except XTAL1, RST, P1.6/SCL, P1.7/SDA	0°C to 70°C -40°C to +85°C		0.2V _{CC} +0.9	V _{CC} +0.5	V
				0.2V _{CC} +1.0	V _{CC} +0.5	V
V _{IH1}	Input high voltage, XTAL1, RST	0°C to 70°C -40°C to +85°C		0.7V _{CC}	V _{CC} +0.5	V
				0.7V _{CC} +0.1	V _{CC} +0.5	V
V _{IH2}	Input high voltage, P1.6/SCL, P1.7/SDA ⁵			3.0	6.0	V
V _{OL}	Output low voltage, ports 1, 2, 3, except P1.6/SCL, P1.7/SDA ¹		I _{OL} = 1.6 mA ¹		0.45	V
V _{OL1}	Output low voltage, port 0, ALE, $\overline{\text{PSEN}}$ ¹		I _{OL} = 3.2 mA ¹		0.45	V
V _{OL2}	Output low voltage, P1.6/SCL, P1.7/SDA		I _{OL} = 3.0 mA ¹		0.4	V
V _{OH}	Output high voltage, ports 1, 2, 3			I _{OH} = -60 μA	2.4	V
				I _{OH} = -25 μA	0.75V _{CC}	V
V _{OH1}	Output high voltage, Port 0 in external bus mode, ALE, $\overline{\text{PSEN}}$, RST			I _{OH} = -800 μA	2.4	V
				I _{OH} = -300 μA	0.75V _{CC}	V
I _{IL}	Logical 0 input current, ports 1, 2, 3, except P1.6/SCL, P1.7/SDA	0°C to 70°C -40°C to +85°C	V _{IN} = 0.45 V		-50	μA
					-75	μA
I _{TL}	Logical 1-to-0 transition current, ports 1, 2, 3, except P1.6/SCL, P1.7/SDA	0°C to 70°C -40°C to +85°C	See Note 3		-650 -750	μA μA
I _{IL1}	Input leakage current, port 0		V _{IN} = V _{IL} or V _{IH}		±10	μA
I _{IL2}	Input leakage current, P1.6/SCL, P1.7/SDA		0 V < V _i < 6.0 V 0 V < V _{CC} < 6.0 V		±10	μA
					μA	
I _{CC}	Power supply current:		See Note 4			
	Active mode @ 16 MHz	0°C to 70°C -40°C to +85°C			25 35	mA
	Idle mode @ 16 MHz	0°C to 70°C -40°C to +85°C			5 6	mA
	Power down mode				50	μA
R _{RST}	Internal reset pull-down resistor			50	300	kΩ
C _{IO}	Pin Capacitance				10	pF

NOTES:

- Capacitive loading on Port 0 and Port 2 may cause spurious noise pulses to be superimposed on the V_{OL}s of ALE and ports 1 and 3. The noise is due to external bus capacitance discharging into the port and port 2 pins when these pins make 1-to-0 transactions during bus operations. In the worst cases (capacitive loading > 100pF), the noise pulse on the ALE pin may exceed 0.8V. In such cases, it may be desirable to qualify ALE with a Schmitt Trigger, or use an address latch with a Schmitt Trigger STROBE input. Under steady state (non-transient) conditions, I_{OL} must be externally limited as follows: 10 mA per port pin, port 0 total (all bits) 26 mA, ports 1, 2, and total each (all bits) 15 mA.
- Capacitive loading on Ports 0 and 2 may cause the V_{OH} on ALE and $\overline{\text{PSEN}}$ to momentarily fall below the 0.9V_{CC} specification when the address bits are stabilizing.
- Pins of ports 1, 2, and 3 source a transition current when they are being externally driven from 1 to 0. The transition current reaches its maximum value when V_{IN} is approximately 2 V.
- See Figures 10 through 13 for I_{CC} test conditions.
- The input threshold voltage of P1.6 and P1.7 (SIO1) meets the I²C specification, so an input voltage below 1.5 V will be recognized as a logic 0 while an input voltage above 3.0 V will be recognized as a logic 1.

80C51 8-bit microcontrollers

16K/32K, 512 OTP, I²C, watchdog timer

87C524/87C528

AC ELECTRICAL CHARACTERISTICS^{1, 2}

SYMBOL	FIGURE	PARAMETER	16MHz CLOCK		VARIABLE CLOCK		UNIT
			MIN	MAX	MIN	MAX	
1/t _{CLCL}	1	Oscillator frequency: 87C528 Speed Versions P878C528EXX			3.5	16	MHz
t _{LHLL}	1	ALE pulse width	85		2t _{CLCL} -40		ns
t _{AVLL}	1	Address valid to ALE low	8		t _{CLCL} -55		ns
t _{LLAX}	1	Address hold after ALE low	28		t _{CLCL} -35		ns
t _{LLIV}	1	ALE low to valid instruction in		150		4t _{CLCL} -100	ns
t _{LLPL}	1	ALE low to $\overline{\text{PSEN}}$ low	23		t _{CLCL} -40		ns
t _{PLPH}	1	$\overline{\text{PSEN}}$ pulse width	143		3t _{CLCL} -45		ns
t _{PLIV}	1	$\overline{\text{PSEN}}$ low to valid instruction in		83		3t _{CLCL} -105	ns
t _{PXIX}	1	Input instruction hold after $\overline{\text{PSEN}}$	0		0		ns
t _{PXIZ}	1	Input instruction float after $\overline{\text{PSEN}}$		38		t _{CLCL} -25	ns
t _{AVIV}	1	Address to valid instruction in		208		5t _{CLCL} -105	ns
t _{PLAZ}	1	$\overline{\text{PSEN}}$ low to address float		10		10	ns
Data Memory							
t _{RLRH}	2, 3	$\overline{\text{RD}}$ pulse width	275		6t _{CLCL} -100		ns
t _{WLWH}	2, 3	$\overline{\text{WR}}$ pulse width	275		6t _{CLCL} -100		ns
t _{RLDV}	2, 3	$\overline{\text{RD}}$ low to valid data in		148		5t _{CLCL} -165	ns
t _{RHDX}	2, 3	Data hold after $\overline{\text{RD}}$	0		0		ns
t _{RHDZ}	2, 3	Data float after $\overline{\text{RD}}$		55		2t _{CLCL} -70	ns
t _{LLDZ}	2, 3	ALE low to valid data in		350		8t _{CLCL} -150	ns
t _{AVDV}	2, 3	Address to valid data in		398		9t _{CLCL} -165	ns
t _{LLWL}	2, 3	ALE low to $\overline{\text{RD}}$ or $\overline{\text{WR}}$ low	138	238	3t _{CLCL} -50	3t _{CLCL} +50	ns
t _{AVWL}	2, 3	Address valid to $\overline{\text{WR}}$ low or $\overline{\text{RD}}$ low	120		4t _{CLCL} -130		ns
t _{QVWX}	2, 3	Data valid to $\overline{\text{WR}}$ transition	3		t _{CLCL} -60		ns
t _{WHQX}	2, 3	Data hold after $\overline{\text{WR}}$	13		t _{CLCL} -50		ns
t _{RLAZ}	2, 3	$\overline{\text{RD}}$ low to address float		0		0	ns
t _{WHLH}	2, 3	$\overline{\text{RD}}$ or $\overline{\text{WR}}$ high to ALE high	23	103	t _{CLCL} -40	t _{CLCL} +40	ns
External Clock							
t _{CHCX}	6	High time	20		20		ns
t _{CLCX}	6	Low time	20		20		ns
t _{CLCH}	6	Rise time		20		20	ns
t _{CHCL}	6	Fall time		20		20	ns
Shift Register							
t _{XLXL}	4	Serial port clock cycle time	750		12t _{CLCL}		ns
t _{QVXH}	4	Output data setup to clock rising edge	492		10t _{CLCL} -133		ns
t _{XHQX}	4	Output data hold after clock rising edge	8		2t _{CLCL} -117		ns
t _{XHDX}	4	Input data hold after clock rising edge	0		0		ns
t _{XHDV}	4	Clock rising edge to input data valid		492		10t _{CLCL} -133	ns

NOTES:

- Parameters are valid over operating temperature range unless otherwise specified.
- Load capacitance for port 0, ALE, and $\overline{\text{PSEN}}$ = 100pF, load capacitance for all other outputs = 80pF.

80C51 8-bit microcontrollers

16K/32K, 512 OTP, I²C, watchdog timer

87C524/87C528

AC ELECTRICAL CHARACTERISTICS – I²C INTERFACE

SYMBOL	PARAMETER	INPUT	OUTPUT	I ² C SPECIFICATION
SCL TIMING CHARACTERISTICS				
t _{HD;STA}	START condition hold time	≥ 14 t _{CLCL} ¹	Note 2	≥ 4.0μs
t _{LOW}	SCL LOW time	≥ 16 t _{CLCL}	Note 2	≥ 4.7μs
t _{HIGH}	SCL HIGH time	≥ 14 t _{CLCL} ¹	≥ 80 t _{CLCL} ³	≥ 4.0μs
t _{RC}	SCL rise time	≤ 1μs ¹	Note 5	≤ 1.0μs
t _{FC}	SCL fall time	≤ 0.3μs ¹	≤ 0.3μs ⁶	≤ 0.3μs
SDA TIMING CHARACTERISTICS				
t _{SU;DAT1}	Data set-up time	≥ 250ns	Note 2	≥ 250ns
t _{HD;DAT}	Data hold time	≥ 0ns	Note 2	≥ 0ns
t _{SU;STA}	Repeated START set-up time	≥ 14 t _{CLCL} ¹	Note 2	≥ 4.7μs
t _{SU;STO}	STOP condition set-up time	≥ 14 t _{CLCL} ¹	Note 2	≥ 4.0μs
t _{BUF}	Bus free time	≥ 14 t _{CLCL} ¹	Note 2	≥ 4.7μs
t _{RD}	SDA rise time	≤ 1μs ⁴	Note 5	≤ 1.0μs
t _{FD}	SDA fall time	≤ 0.3μs ⁴	≤ 0.3μs ⁶	≤ 0.3μs

NOTES:

- At f_{CLK} = 3.5MHz, this evaluates to 14 × 286ns = 4μs, i.e., the bit-level I²C interface can respond to the I²C protocol for f_{CLK} ≥ 3.5 MHz.
- This parameter is determined by the user software, it has to comply with the I²C.
- This value gives the autoclock pulse length which meets the I²C specification for the specified XTAL clock frequency range. Alternatively, the SCL pulse may be timed by software.
- Spikes on SDA and SCL lines with a duration of less than 4 × f_{CLK} will be filtered out.
- The rise time is determined by the external bus line capacitance and pull-up resistor, it must be ≤ 1μs.
- The maximum capacitance on bus lines SDA and SCL is 400pF.

80C51 8-bit microcontrollers 16K/32K, 512 OTP, I²C, watchdog timer

87C524/87C528

EXPLANATION OF THE AC SYMBOLS

Each timing symbol has five characters. The first character is always 't' (= time). The other characters, depending on their positions, indicate the name of a signal or the logical status of that signal. The designations are:

- A – Address
- C – Clock
- D – Input data
- H – Logic level high
- I – Instruction (program memory contents)
- L – Logic level low, or ALE

- P – $\overline{\text{PSEN}}$
- Q – Output data
- R – $\overline{\text{RD}}$ signal
- t – Time
- V – Valid
- W – $\overline{\text{WR}}$ signal
- X – No longer a valid logic level
- Z – Float

Examples: t_{AVLL} = Time for address valid to ALE low.
 t_{LLPL} = Time for ALE low to $\overline{\text{PSEN}}$ low.

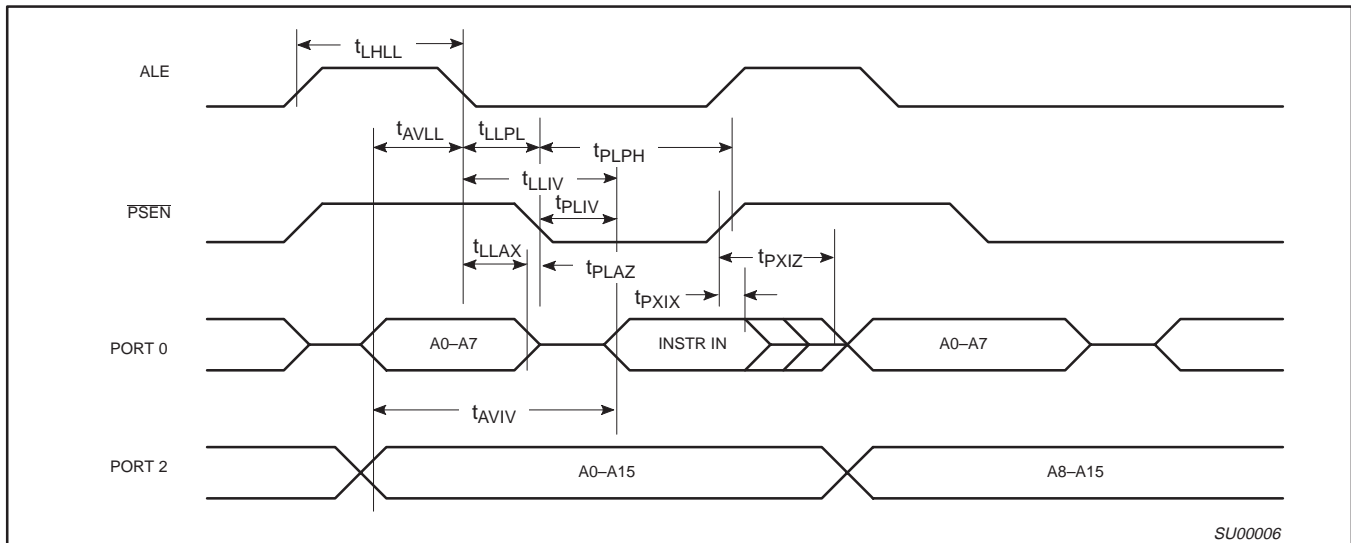

Figure 1. External Program Memory Read Cycle

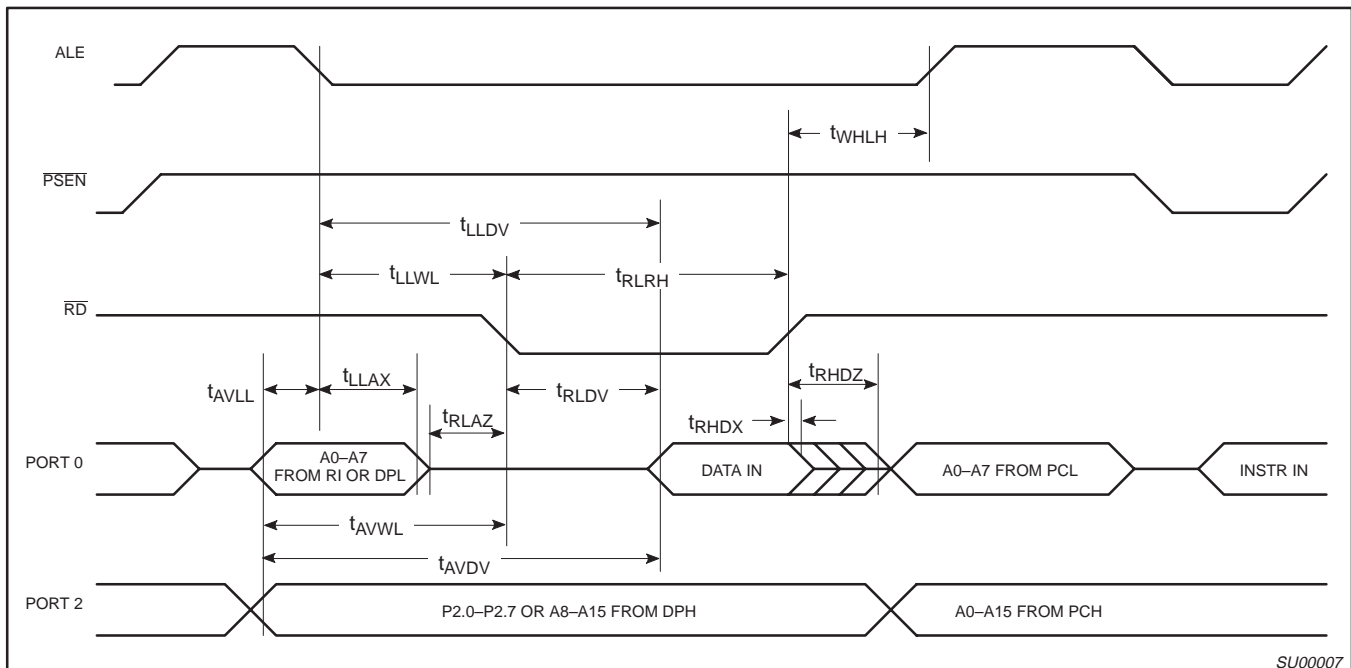

Figure 2. External Data Memory Read Cycle

80C51 8-bit microcontrollers
16K/32K, 512 OTP, I²C, watchdog timer

87C524/87C528

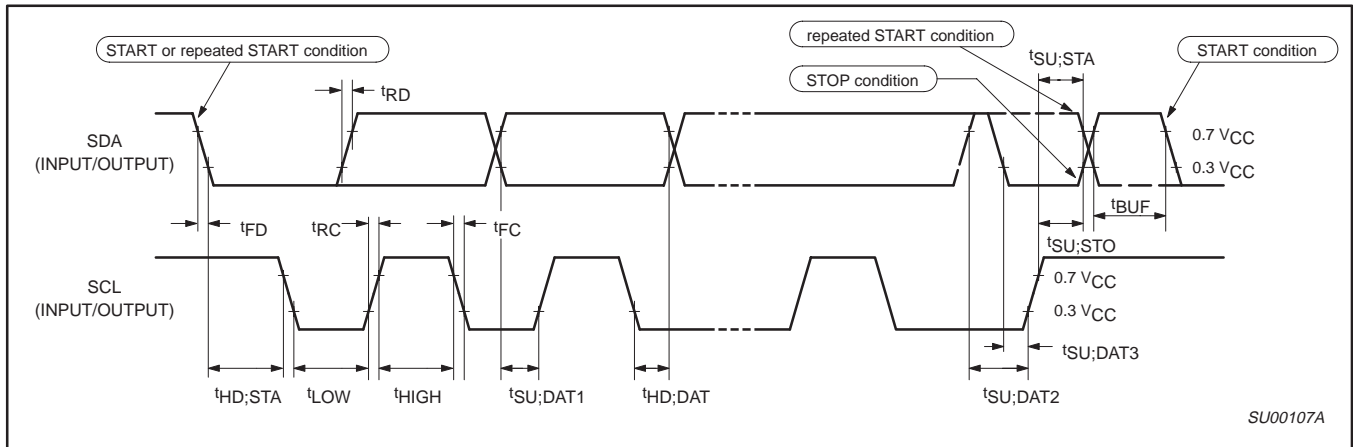

Figure 5. Timing SIO1 (I²C) Interface

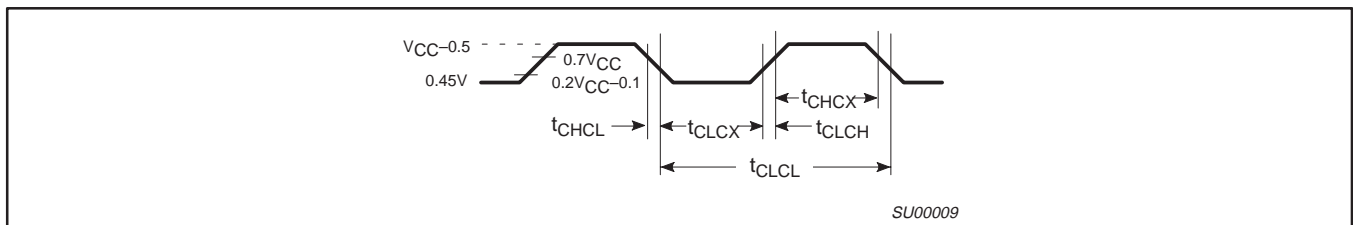

Figure 6. External Clock Drive

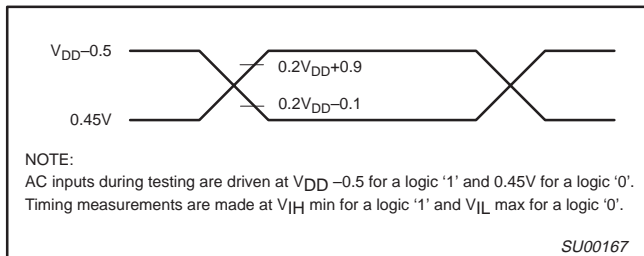

Figure 7. AC Testing Input/Output

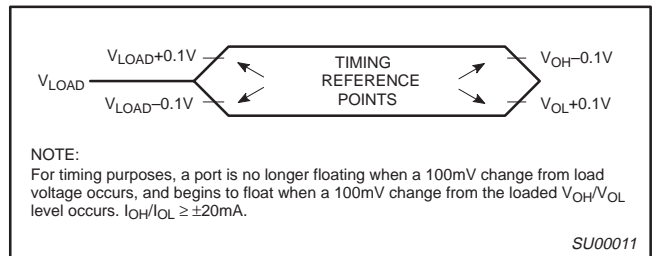

Figure 8. Float Waveform

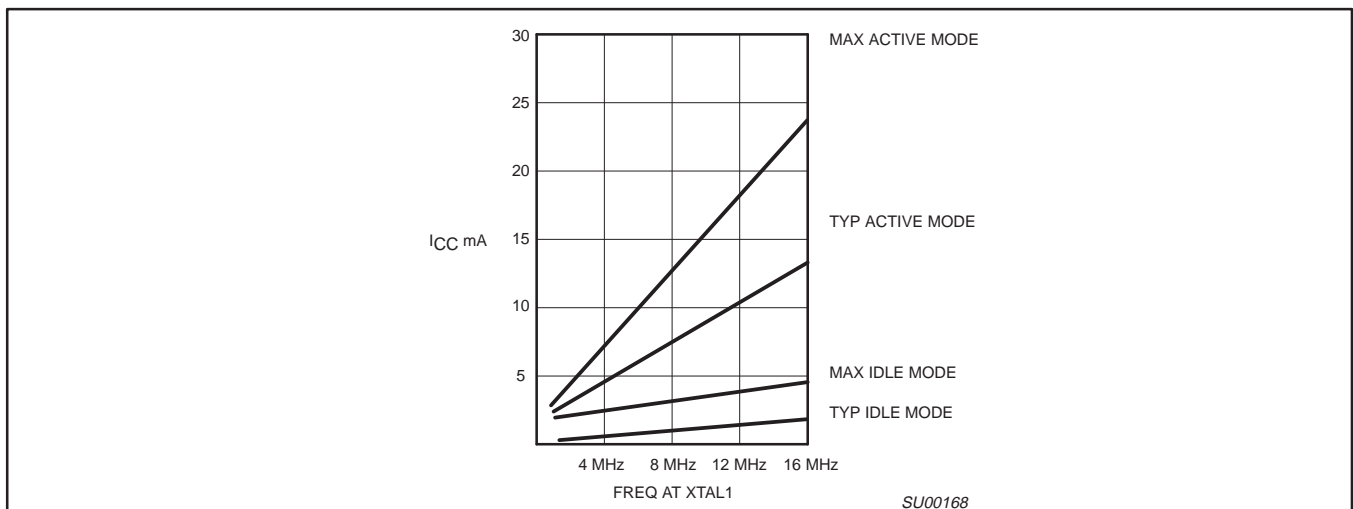

Figure 9. I_{CC} vs. FREQ.
Valid only within frequency specifications of the device under test

80C51 8-bit microcontrollers
16K/32K, 512 OTP, I²C, watchdog timer

87C524/87C528

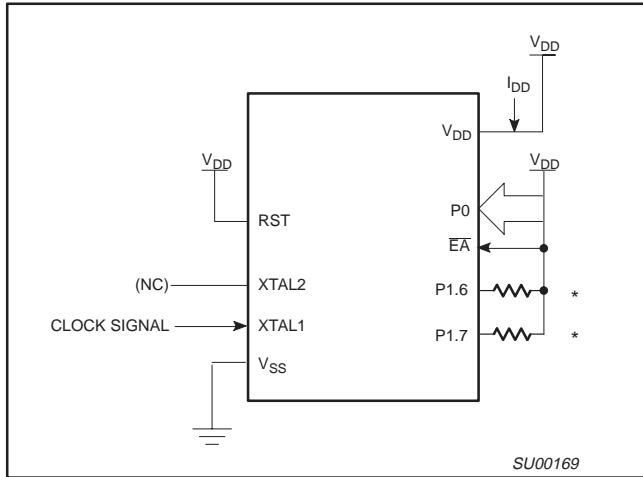

Figure 10. I_{DD} Test Condition, Active Mode
All other pins are disconnected

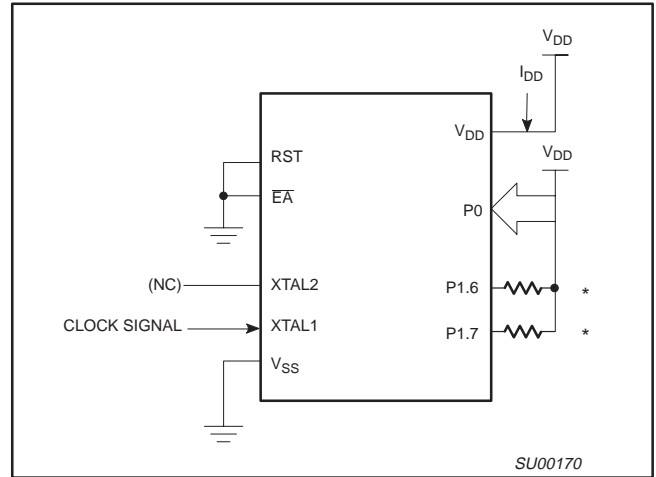

Figure 11. I_{DD} Test Condition, Idle Mode
All other pins are disconnected

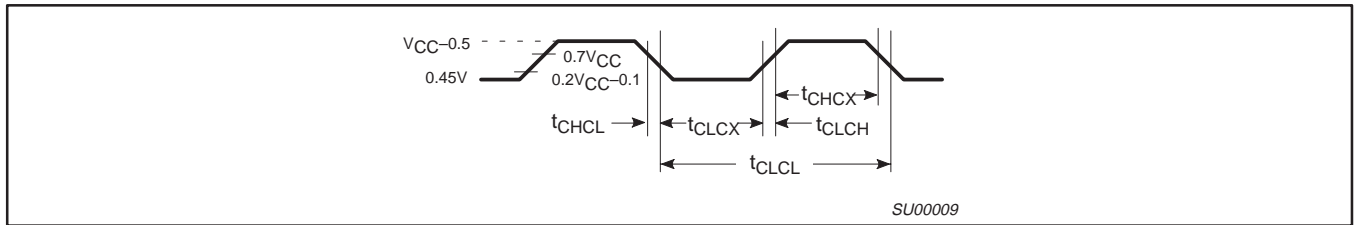

Figure 12. Clock Signal Waveform for
I_{DD} Tests in Active and Idle Modes
t_{CLCH} = t_{CHCL} = 5ns

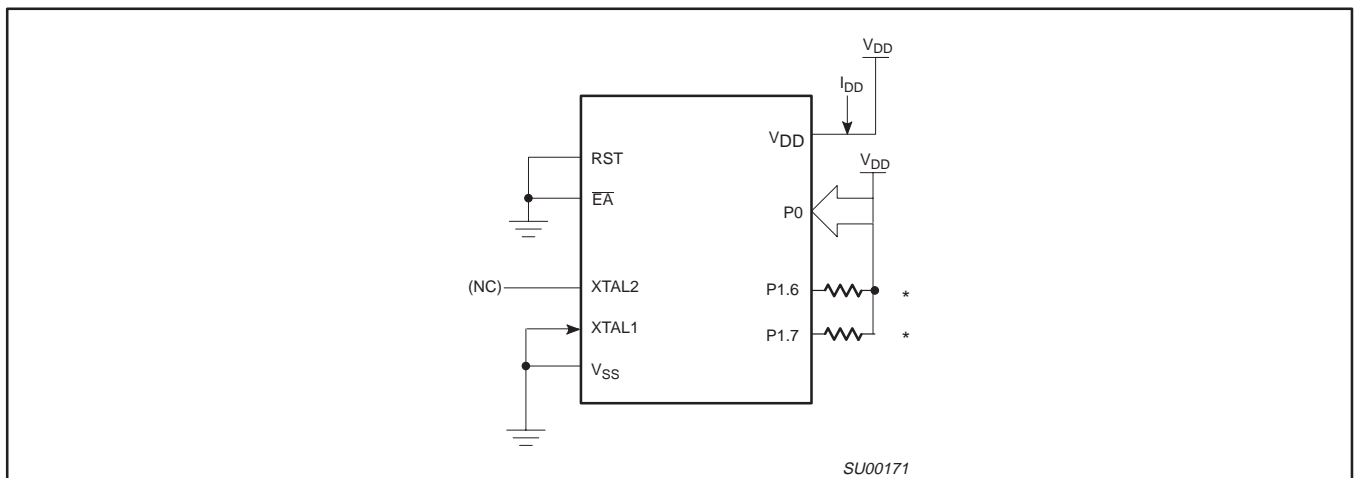

Figure 13. I_{DD} Test Condition, Power Down Mode
All other pins are disconnected. V_{DD} = 2V to 5.5V

NOTE:

* Ports 1.6 and 1.7 should be connected to V_{DD} through resistors of sufficiently high value such that the sink current into these pins does not exceed the I_{OL1} specifications.

80C51 8-bit microcontrollers 16K/32K, 512 OTP, I²C, watchdog timer

87C524/87C528

EPROM CHARACTERISTICS FOR 87C528

The 87C528 is programmed by using a modified Quick-Pulse Programming™ algorithm. It differs from older methods in the value used for V_{PP} (programming supply voltage) and in the width and number of the ALE/PROG pulses.

The 87C528 contains two signature bytes that can be read and used by an EPROM programming system to identify the device. The signature bytes identify the device as an 87C528 manufactured by Philips.

Table 6 shows the logic levels for reading the signature byte, and for programming the program memory, the encryption table, and the lock bits. The circuit configuration and waveforms for quick-pulse programming are shown in Figures 14 and 15. Figure 16 shows the circuit configuration for normal program memory verification.

Quick-Pulse Programming

The setup for microcontroller quick-pulse programming is shown in Figure 14. Note that the 87C528 is running with a 4 to 6MHz oscillator. The reason the oscillator needs to be running is that the device is executing internal address and program data transfers.

The address of the EPROM location to be programmed is applied to ports 1, 2 and 3, as shown in Figure 14. The code byte to be programmed into that location is applied to port 0. RST, PSEN and pins of ports 2 and 3 specified in Table 6 are held at the 'Program Code Data' levels indicated in Table 6. The ALE/PROG is pulsed low 25 times as shown in Figure 15.

To program the encryption table, repeat the 25 pulse programming sequence for addresses 0 through 3FH, using the 'Pgm Encryption Table' levels. Do not forget that after the encryption table is programmed, verification cycles will produce only encrypted data.

To program the lock bits, repeat the 25 pulse programming sequence using the 'Pgm Lock Bit' levels. After one lock bit is programmed, further programming of the code memory and encryption table is disabled. However, the other lock bit can still be programmed.

Note that the EA/V_{PP} pin must not be allowed to go above the maximum specified V_{PP} level for any amount of time. Even a narrow glitch above that voltage can cause permanent damage to the device. The V_{PP} source should be well regulated and free of glitches and overshoot.

Program Verification

If lock bit 2 has not been programmed, the on-chip program memory can be read out for program verification. The address of the program memory locations to be read is applied to ports 1, 2 and 3 as shown in Figure 16. The other pins are held at the 'Verify Code Data' levels indicated in Table 6. The contents of the address location will be emitted on port 0. External pull ups are required on port 0 for this operation.

If the encryption table has been programmed, the data presented at port 0 will be the exclusive NOR of the program byte with one of the encryption bytes. The user will have to know the encryption table contents in order to correctly decode the verification data. The encryption table itself cannot be read out.

Reading the Signature Bytes

The signature bytes are read by the same procedure as a normal verification of locations 030H and 031 H, except that P3.6 and P3.7 need to be pulled to a logic low. The values are:

- (030H) = 15H indicates manufactured by Philips
- (031H) = 9BH indicates 87C528

Program Lock Bits

The 87C528 has 3 programmable lock bits that will provide different levels of protection for the on-chip code and data (see Table 7).

Erasing the EPROM also erases the encryption array and the program lock bits, returning the part to full functionality.

Program/Verify Algorithms

Any algorithm in agreement with the conditions listed in Table 6, and which satisfies the timing specifications, is suitable.

Table 6. EPROM Programming Modes

MODE	RST	PSEN	ALE/PROG	EA/V _{PP}	P2.7	P2.6	P3.7	P3.6
Read signature	1	0	1	1	0	0	0	0
Program code data	1	0	0*	V _{PP}	1	0	1	1
Verify code data	1	0	1	1	0	0	1	1
Pgm encryption table	1	0	0*	V _{PP}	1	0	1	0
Pgm lock bit 1	1	0	0*	V _{PP}	1	1	1	1
Pgm lock bit 2	1	0	0*	V _{PP}	1	1	0	0
Pgm lock bit 3	1	0	0*	V _{PP}	0	1	0	1

NOTES:

1. '0' = Valid low for that pin, '1' = valid high for that pin.
2. V_{PP} = 12.75 V ±0.25 V.
3. V_{CC} = 5 V ±10% during programming and verification.
- * ALE/PROG receives 25 programming pulses while V_{PP} is held at 12.75 V. Each programming pulse is low for 100 μs (±10 μs) and high for a minimum of 10 μs.

80C51 8-bit microcontrollers

16K/32K, 512 OTP, I²C, watchdog timer

87C524/87C528

EPROM CHARACTERISTICS FOR 87C524

The 87C524 is programmed by using a modified Quick-Pulse Programming™ algorithm. It differs from older methods in the value used for V_{PP} (programming supply voltage) and in the width and number of the ALE/PROG pulses.

The 87C524 contains two signature bytes that can be read and used by an EPROM programming system to identify the device. The signature bytes identify the device as an 87C524 manufactured by Philips.

Table 6 shows the logic levels for reading the signature byte, and for programming the program memory, the encryption table, and the lock bits. The circuit configuration and waveforms for quick-pulse programming are shown in Figures 14 and 15. Figure 16 shows the circuit configuration for normal program memory verification.

Quick-Pulse Programming

The setup for microcontroller quick-pulse programming is shown in Figure 14. Note that the 87C524 is running with a 4 to 6 MHz oscillator. The reason the oscillator needs to be running is that the device is executing internal address and program data transfers.

The address of the EPROM location to be programmed is applied to ports 1, 2 and 3, as shown in Figure 14. The code byte to be programmed into that location is applied to port 0. RST, \overline{PSEN} and pins of ports 2 and 3 specified in Table 6 are held at the 'Program Code Data' levels indicated in Table 6. The ALE/PROG is pulsed low 25 times as shown in Figure 15.

To program the encryption table, repeat the 25 pulse programming sequence for addresses 0 through 3FH, using the 'Pgm Encryption Table' levels. Do not forget that after the encryption table is programmed, verification cycles will produce only encrypted data.

To program the lock bits, repeat the 25 pulse programming sequence using the 'Pgm Lock Bit' levels. After one lock bit is programmed, further programming of the code memory and encryption table is disabled. However, the other lock bit can still be programmed.

Note that the \overline{EA}/V_{PP} pin must not be allowed to go above the maximum specified V_{PP} level for any amount of time. Even a narrow glitch above that voltage can cause permanent damage to the device. The V_{PP} source should be well regulated and free of glitches and overshoot.

Program Verification

If lock bit 2 has not been programmed, the on-chip program memory can be read out for program verification. The address of the program memory locations to be read is applied to ports 1, 2 and 3 as shown

in Figure 16. The other pins are held at the 'Verify Code Data' levels indicated in Table 6. The contents of the address location will be emitted on port 0. External pull-ups are required on port 0 for this operation.

If the encryption table has been programmed, the data presented at port 0 will be the exclusive NOR of the program byte with one of the encryption bytes. The user will have to know the encryption table contents in order to correctly decode the verification data. The encryption table itself cannot be read out.

Program Lock Bits

The 87C524 has 3 programmable lock bits that will provide different levels of protection for the on-chip code and data (see Table 7).

Erasing the EPROM also erases the encryption array and the program lock bits, returning the part to full functionality.

Reading the Signature Bytes

The signature bytes are read by the same procedure as a normal verification of locations 030H and 031H, except that P3.6 and P3.7 need to be pulled to a logic low. The values are:

(030H) = 15H indicates manufactured by Philips

(031H) = 9DH indicates 87C524

Program/Verify Algorithms

Any algorithm in agreement with the conditions listed in Table 6, and which satisfies the timing specifications, is suitable.

Erasure Characteristics

Erasure of the EPROM begins to occur when the chip is exposed to light with wavelengths shorter than approximately 4,000 angstroms. Since sunlight and fluorescent lighting have wavelengths in this range, exposure to these light sources over an extended time (about 1 week in sunlight, or 3 years in room level fluorescent lighting) could cause inadvertent erasure. **For this and secondary effects, it is recommended that an opaque label be placed over the window.** For elevated temperature or environments where solvents are being used, apply Kapton tape Fluorglas part number 2345-5, or equivalent.

The recommended erasure procedure is exposure to ultraviolet light (at 2537 angstroms) to an integrated dose of at least 15W-sec/cm². Exposing the EPROM to an ultraviolet lamp of 12,000uW/cm² rating for 20 to 39 minutes, at a distance of about 1 inch, should be sufficient.

Erasure leaves the array in an all 1s state.

™Trademark phrase of Intel Corporation.

80C51 8-bit microcontrollers 16K/32K, 512 OTP, I²C, watchdog timer

87C524/87C528

Table 7. Program Lock Bits

PROGRAM LOCK BITS ^{1,2}				PROTECTION DESCRIPTION
	LB1	LB2	LB3	
1	U	U	U	No Program Lock features enabled. (Code verify will still be encrypted by the Encryption Array if programmed.)
2	P	U	U	MOV _C instructions executed from external program memory are disabled from fetching code bytes from Internal memory, EA is jumped and latched on Reset, and further programming of the EPROM is disabled.
3	P	P	U	Same as 2, also verify is disabled.
4	P	P	P	Same as 3, external execution is disabled. Internal data RAM is not accessible.

NOTES:

1. P - programmed. U - unprogrammed.
2. Any other combination of the lock bits is not defined.

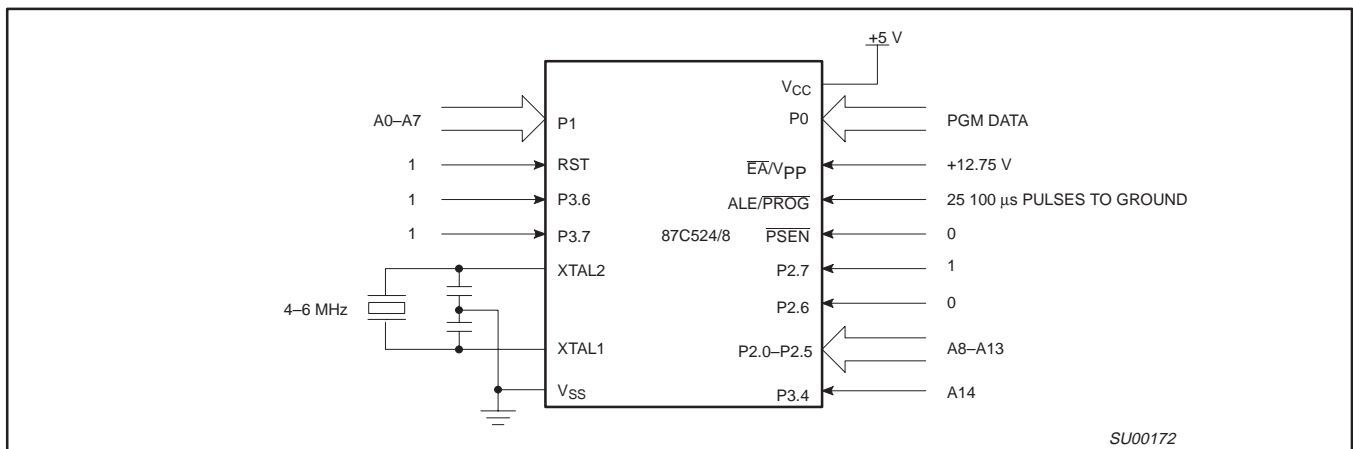

Figure 14. Programming Configuration

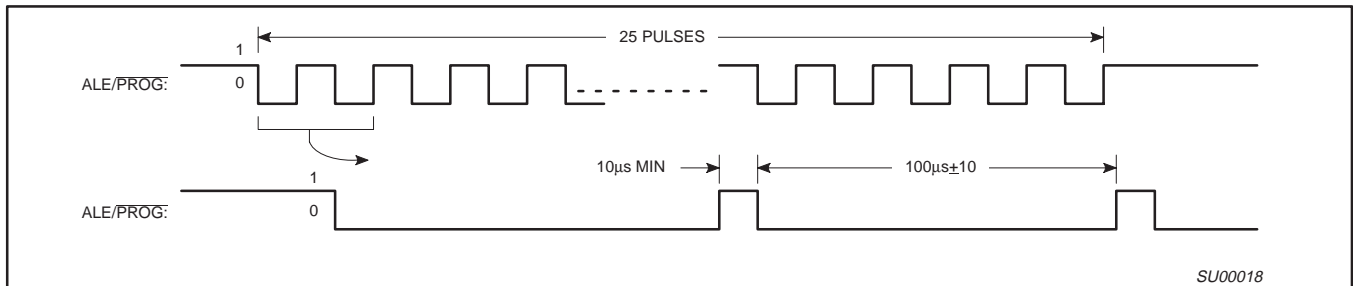

Figure 15. PROG Waveform

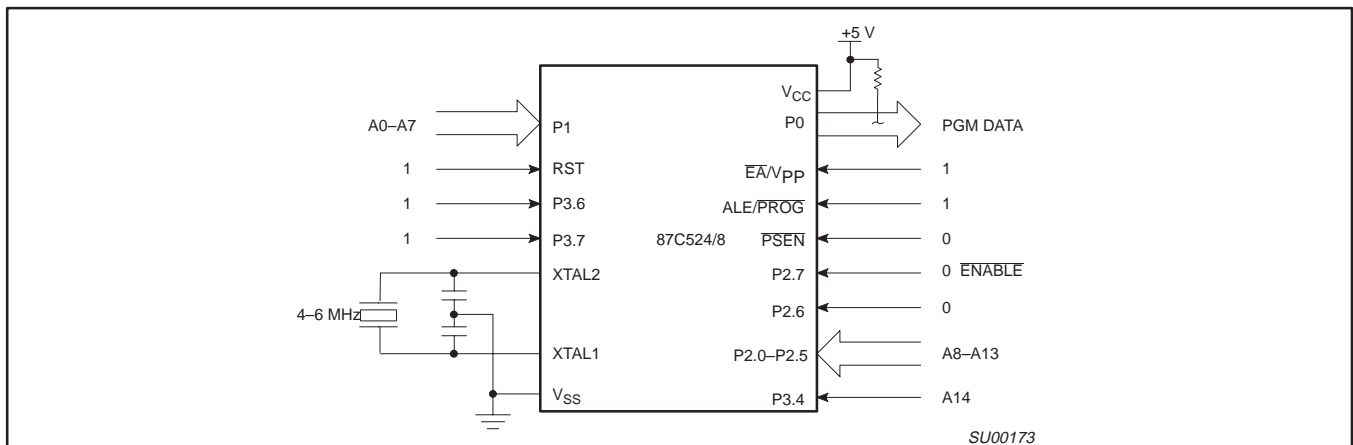

Figure 16. Program Verification

80C51 8-bit microcontrollers 16K/32K, 512 OTP, I²C, watchdog timer

87C524/87C528

EPROM PROGRAMMING AND VERIFICATION CHARACTERISTICS

T_{amb} = 21°C to +27°C, V_{cc} = 5 V±10%, V_{SS} = 0 V (See Figure 17)

SYMBOL	PARAMETER	MIN	MAX	UNIT
V _{PP}	Programming supply voltage	12.5	13.0	V
I _{PP}	Programming supply current		50	mA
1/t _{CLCL}	Oscillator frequency	4	6	MHz
t _{AVGL}	Address setup to PROG low	48t _{CLCL}		
t _{GHAX}	Address hold after PROG	48t _{CLCL}		
t _{DVGL}	Data setup to PROG low	48t _{CLCL}		
t _{GHDX}	Data hold after PROG	48t _{CLCL}		
t _{EHS}	P2.7 (ENABLE) high to V _{PP}	48t _{CLCL}		
t _{SHGL}	V _{PP} setup to PROG low	10		μs
t _{GHSL}	V _{PP} hold after PROG	10		μs
t _{GLGH}	PROG width	90	110	μs
t _{AVQV}	Address to data valid		48t _{CLCL}	
t _{ELQZ}	ENABLE low to data valid		48t _{CLCL}	
t _{EHQZ}	Data float after ENABLE	0	48t _{CLCL}	
t _{GHGL}	PROG high to PROG low	10		μs

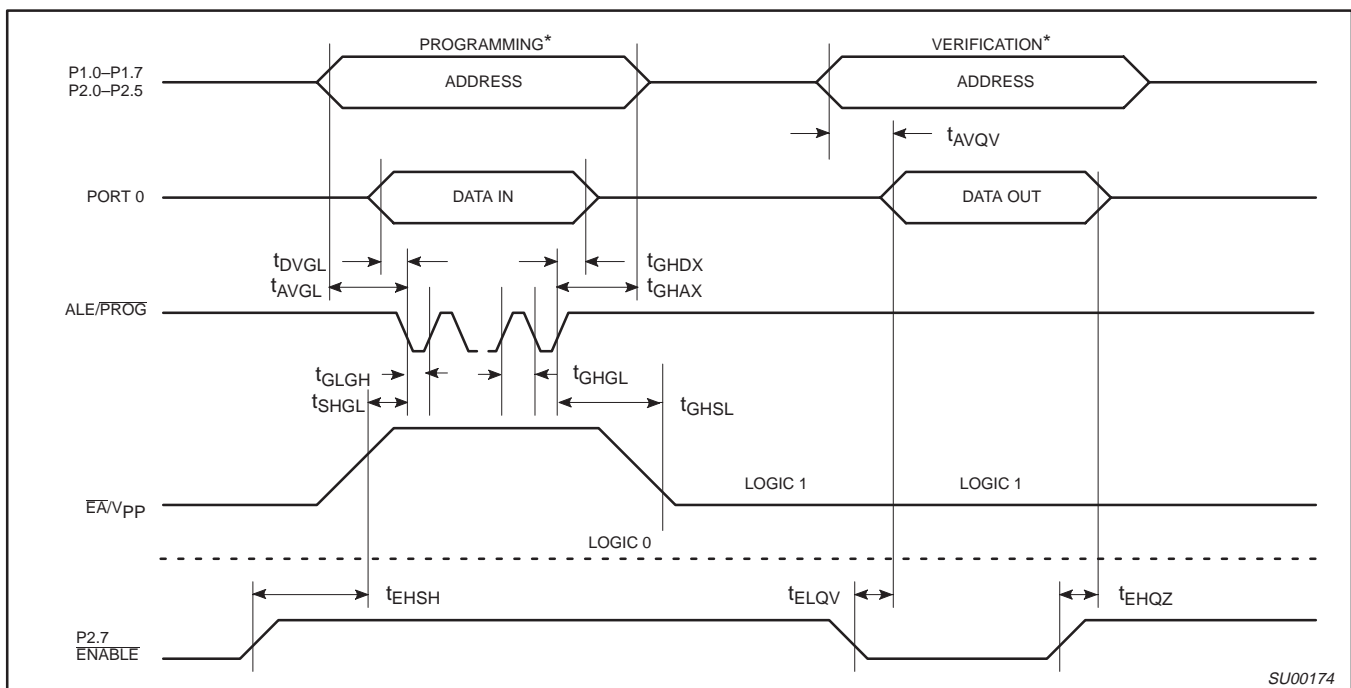

NOTE:

* FOR PROGRAMMING VERIFICATION SEE FIGURE 14.
FOR VERIFICATION CONDITIONS SEE FIGURE 16.

Figure 17. EPROM Programming and Verification



Purchase of Philips I²C components conveys a license under the Philips' I²C patent to use the components in the I²C system provided the system conforms to the I²C specifications defined by Philips. This specification can be ordered using the code 9398 393 40011.

80C51 8-bit microcontrollers
16K/32K, 512 OTP, I²C, watchdog timer

87C524/87C528

DIP40: plastic dual in-line package; 40 leads (600 mil)

SOT129-1

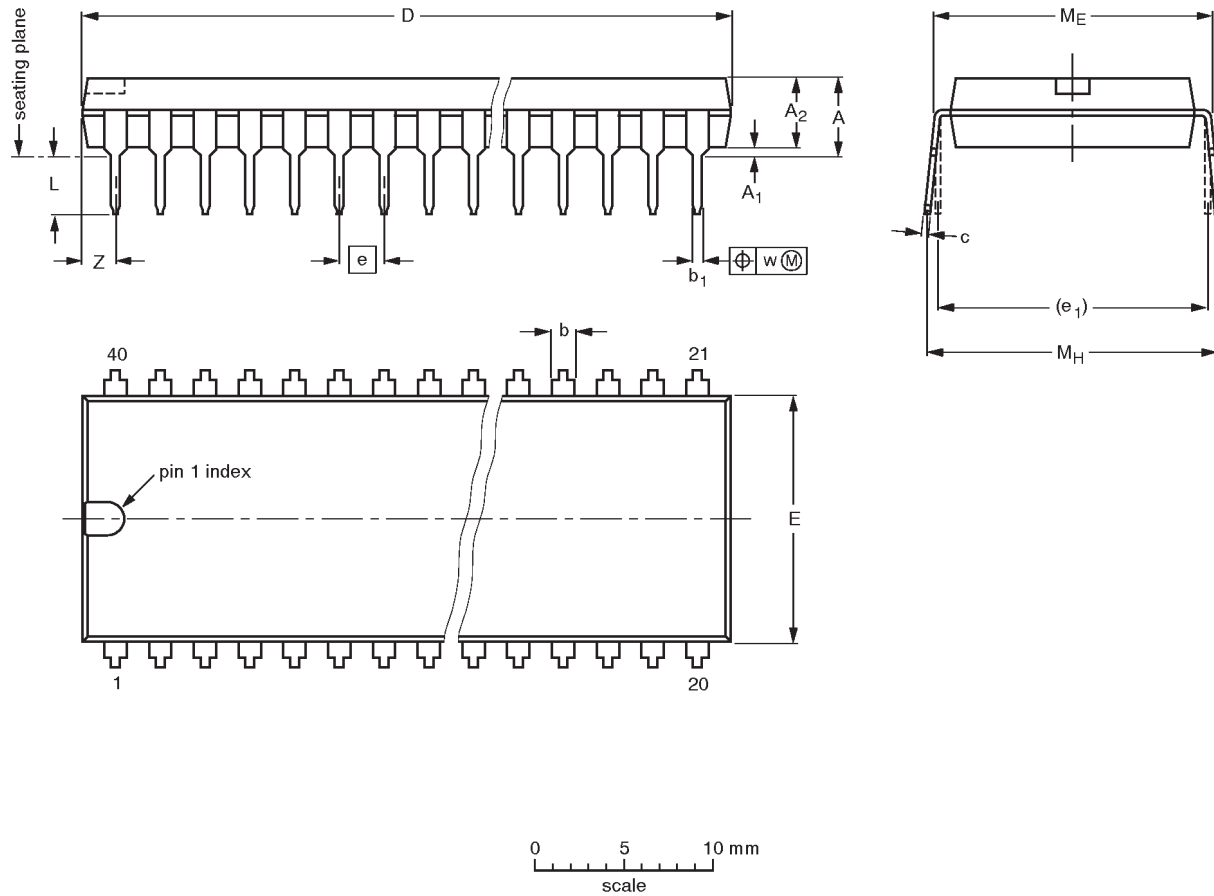

DIMENSIONS (inch dimensions are derived from the original mm dimensions)

UNIT	A max.	A ₁ min.	A ₂ max.	b	b ₁	c	D ⁽¹⁾	E ⁽¹⁾	e	e ₁	L	M _E	M _H	w	Z ⁽¹⁾ max.
mm	4.7	0.51	4.0	1.70 1.14	0.53 0.38	0.36 0.23	52.50 51.50	14.1 13.7	2.54	15.24	3.60 3.05	15.80 15.24	17.42 15.90	0.254	2.25
inches	0.19	0.020	0.16	0.067 0.045	0.021 0.015	0.014 0.009	2.067 2.028	0.56 0.54	0.10	0.60	0.14 0.12	0.62 0.60	0.69 0.63	0.01	0.089

Note

1. Plastic or metal protrusions of 0.25 mm maximum per side are not included.

OUTLINE VERSION	REFERENCES				EUROPEAN PROJECTION	ISSUE DATE
	IEC	JEDEC	EIAJ			
SOT129-1	051G08	MO-015AJ				92-11-17 95-01-14

80C51 8-bit microcontrollers
16K/32K, 512 OTP, I²C, watchdog timer

87C524/87C528

PLCC44: plastic leaded chip carrier; 44 leads

SOT187-2

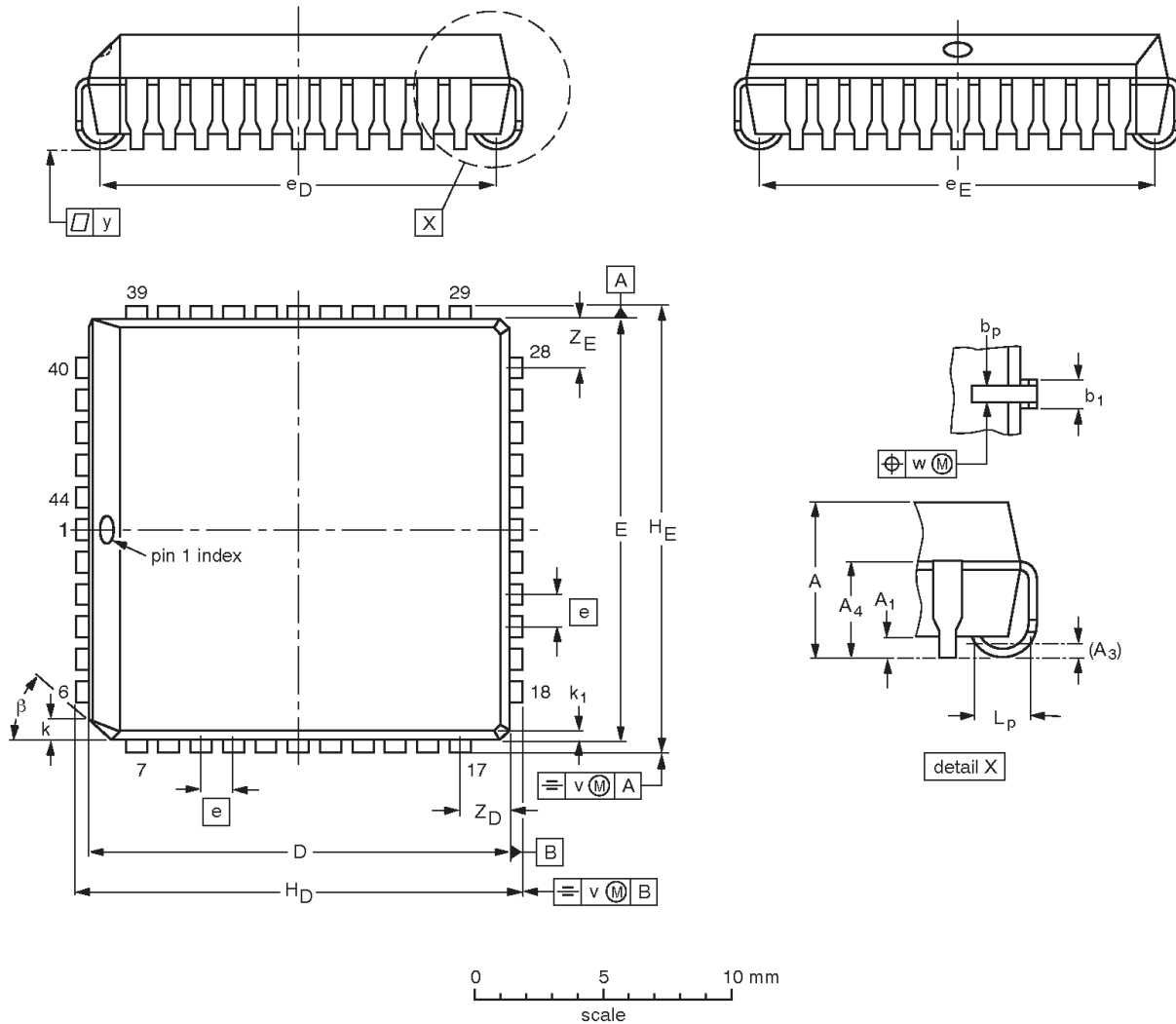

DIMENSIONS (millimetre dimensions are derived from the original inch dimensions)

UNIT	A	A ₁ min.	A ₃	A ₄ max.	b _p	b ₁	D ⁽¹⁾	E ⁽¹⁾	e	e _D	e _E	H _D	H _E	k	k ₁ max.	L _p	v	w	y	Z _D ⁽¹⁾ max.	Z _E ⁽¹⁾ max.	β
mm	4.57 4.19	0.51	0.25	3.05	0.53 0.33	0.81 0.66	16.66 16.51	16.66 16.51	1.27	16.00 14.99	16.00 14.99	17.65 17.40	17.65 17.40	1.22 1.07	0.51	1.44 1.02	0.18	0.18	0.10	2.16	2.16	45°
inches	0.180 0.165	0.020	0.01	0.12	0.021 0.013	0.032 0.026	0.656 0.650	0.656 0.650	0.05	0.630 0.590	0.630 0.590	0.695 0.685	0.695 0.685	0.048 0.042	0.020	0.057 0.040	0.007	0.007	0.004	0.085	0.085	

Note

1. Plastic or metal protrusions of 0.01 inches maximum per side are not included.

OUTLINE VERSION	REFERENCES				EUROPEAN PROJECTION	ISSUE DATE
	IEC	JEDEC	EIAJ			
SOT187-2	112E10	MO-047AC				95-02-25 97-12-16

80C51 8-bit microcontrollers
16K/32K, 512 OTP, I²C, watchdog timer

87C524/87C528

QFP44: plastic quad flat package; 44 leads (lead length 1.3 mm); body 10 x 10 x 1.75 mm

SOT307-2

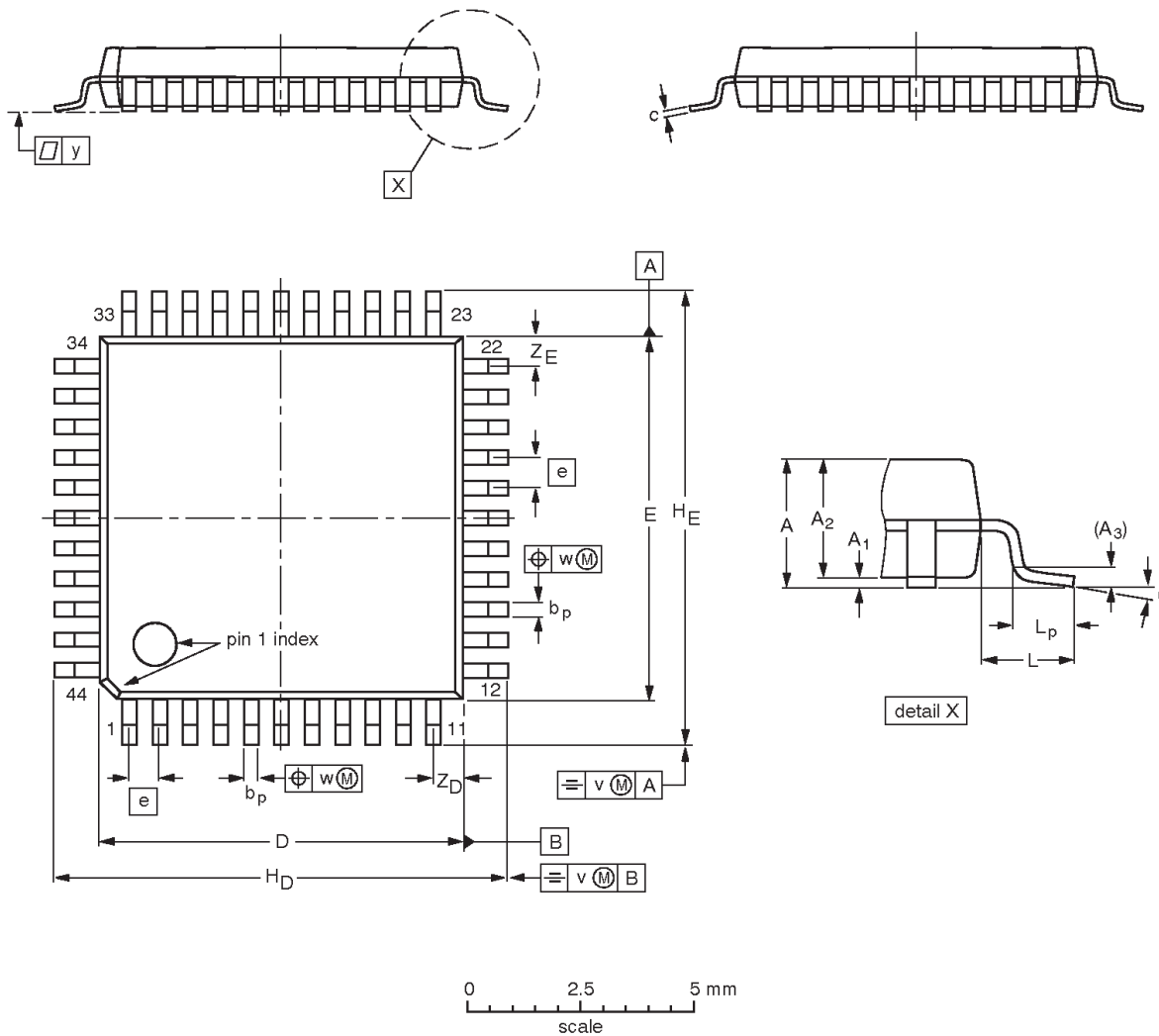

DIMENSIONS (mm are the original dimensions)

UNIT	A _{max.}	A ₁	A ₂	A ₃	b _p	c	D ⁽¹⁾	E ⁽¹⁾	e	H _D	H _E	L	L _p	v	w	y	Z _D ⁽¹⁾	Z _E ⁽¹⁾	θ
mm	2.10	0.25 0.05	1.85 1.65	0.25	0.40 0.20	0.25 0.14	10.1 9.9	10.1 9.9	0.8	12.9 12.3	12.9 12.3	1.3	0.95 0.55	0.15	0.15	0.1	1.2 0.8	1.2 0.8	10° 0°

Note

1. Plastic or metal protrusions of 0.25 mm maximum per side are not included.

OUTLINE VERSION	REFERENCES			EUROPEAN PROJECTION	ISSUE DATE
	IEC	JEDEC	EIAJ		
SOT307-2					95-02-04 97-08-01

80C51 8-bit microcontrollers
16K/32K, 512 OTP, I²C, watchdog timer

87C524/87C528

NOTES

80C51 8-bit microcontrollers

16K/32K, 512 OTP, I²C, watchdog timer

87C524/87C528

Data sheet status

Data sheet status	Product status	Definition [1]
Objective specification	Development	This data sheet contains the design target or goal specifications for product development. Specification may change in any manner without notice.
Preliminary specification	Qualification	This data sheet contains preliminary data, and supplementary data will be published at a later date. Philips Semiconductors reserves the right to make changes at any time without notice in order to improve design and supply the best possible product.
Product specification	Production	This data sheet contains final specifications. Philips Semiconductors reserves the right to make changes at any time without notice in order to improve design and supply the best possible product.

[1] Please consult the most recently issued datasheet before initiating or completing a design.

Definitions

Short-form specification — The data in a short-form specification is extracted from a full data sheet with the same type number and title. For detailed information see the relevant data sheet or data handbook.

Limiting values definition — Limiting values given are in accordance with the Absolute Maximum Rating System (IEC 134). Stress above one or more of the limiting values may cause permanent damage to the device. These are stress ratings only and operation of the device at these or at any other conditions above those given in the Characteristics sections of the specification is not implied. Exposure to limiting values for extended periods may affect device reliability.

Application information — Applications that are described herein for any of these products are for illustrative purposes only. Philips Semiconductors make no representation or warranty that such applications will be suitable for the specified use without further testing or modification.

Disclaimers

Life support — These products are not designed for use in life support appliances, devices or systems where malfunction of these products can reasonably be expected to result in personal injury. Philips Semiconductors customers using or selling these products for use in such applications do so at their own risk and agree to fully indemnify Philips Semiconductors for any damages resulting from such application.

Right to make changes — Philips Semiconductors reserves the right to make changes, without notice, in the products, including circuits, standard cells, and/or software, described or contained herein in order to improve design and/or performance. Philips Semiconductors assumes no responsibility or liability for the use of any of these products, conveys no license or title under any patent, copyright, or mask work right to these products, and makes no representations or warranties that these products are free from patent, copyright, or mask work right infringement, unless otherwise specified.

Philips Semiconductors
811 East Arques Avenue
P.O. Box 3409
Sunnyvale, California 94088-3409
Telephone 800-234-7381

© Copyright Philips Electronics North America Corporation 1998
All rights reserved. Printed in U.S.A.

Date of release: 07-99

Document order number:

9397 750 06229

Let's make things better.



LittleDiode supplies new, hard to find or obsolete electronic components and semiconductors all over the world.

With over two million different components listed you are sure to find the part you need.

Feel free to visit us today at our online store:

LittleDiode.com

Looking forward to providing you with the best possible service.