

DUAL OPERATIONAL AMPLIFIERS

The NE5532 is an internally compensated dual low noise op AMP. The high small signal and power bandwidths provides superior performance in high quality AMP, all control circuits, and telephone applications.

FEATURE

- Internal frequency compensation
- Slew Rate: 8V/μs
- Input noise voltage: $8nV/\sqrt{Hz}$ ($f_0 = 30Hz$)
- Full power bandwidth: 140KHz

BLOCK DIAGRAM

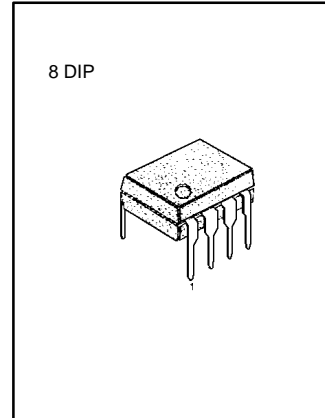
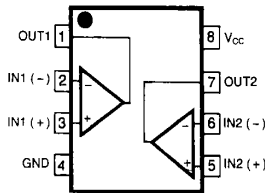

ORDERING INFORMATION

Device	Package	Operating Temperature
NE5532 (KA5532)	8 DIP	0 ~ + 70 °C

ABSOLUTE MAXIMUM RATINGS ($T_A = 25^\circ C$)

Characteristics	Symbol	NE5532	Unit
Power Supply Voltage	V_{CC}	± 22	V
Differential Input Voltage	V_{IO}	13	V
Input Voltage	V_I	Supply Voltage	V
Power Dissipation	P_D	1000	mW
Operating Temperature Range	T_{OPR}	0 ~ + 70	°C

ELECTRICAL CHARACTERISTICS ($V_{CC} = -5V, V_{EE} = -15V, T_A = 25^\circ C$)

Characteristic	Symbol	Test Conditions	Min	Typ	Max	Unit
Input Offset Voltage	V_{IO}			0.5	4.0	mV
Input Offset Current	I_{IO}			10	150	nA
Input Bias Current	I_{BIAS}			200	800	nA
Supply Current	I_{CC}			6.0	16	mA
Input Voltage Range	$V_{I(R)}$		± 12	± 13		V
Common Mode Rejection Range	CMRR	$T_A = 25^\circ C$	70	100		dB
Power Supply Rejection Ratio	PSRR	$T_A = 25^\circ C$	80	100		dB
Output Voltage Swing	$V_{O(P,P)}$	$R_L \geq 600\Omega$	± 12	± 13		V
Input Resistance	R_I	$T_A = 25^\circ C$	30	300		KΩ
Short Circuit Current	I_{SC}			38		mA
Overshoot	O_S	$R_L = 600\Omega, C_L = 100pF$		10	20	%
Gain	G_V	$f = 10KHz$	2	2.2		V/mV
Gain Bandwidth Product	GBW	$C_L = 100pF, R_L = 600\Omega$	8	10		MHz
Slew Rate	SR	$R_L = 1K, C_L = 100pF, R_L = 600\Omega$	6	8.0		V/μs
Input Noise Voltage	V_{NI}	$f_0 = 30Hz$ $f_0 = 1KHz$		8.0 5.0		nV/√Hz

TYPICAL PERFORMANCE CHARACTERISTICS

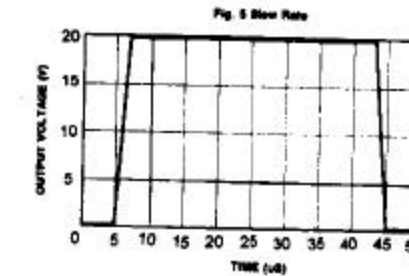
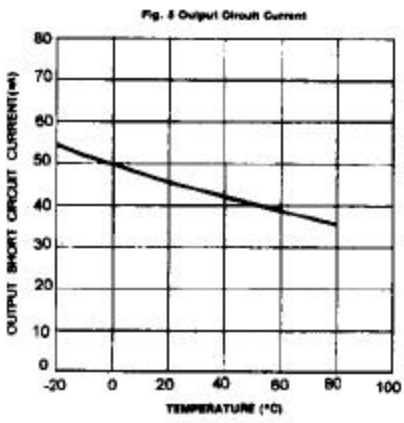
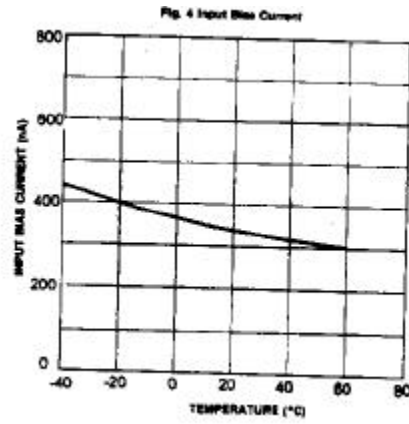
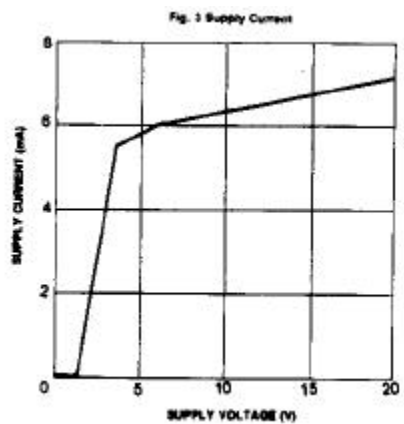
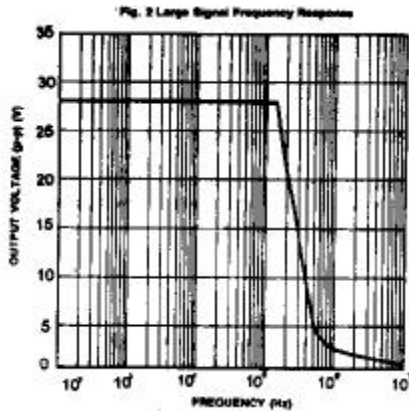
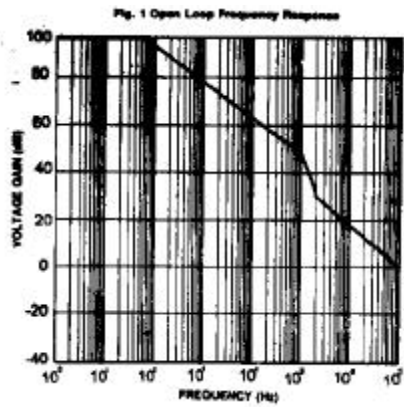

TRADEMARKS

The following are registered and unregistered trademarks Fairchild Semiconductor owns or is authorized to use and is not intended to be an exhaustive list of all such trademarks.

ACE ^x ™	ISOPLANAR™	TinyLogic™
CoolFET™	MICROWIRE™	UHC™
CROSSVOLT™	POP™	VCX™
E ² CMOS™	PowerTrench®	
FACT™	QFET™	
FACT Quiet Series™	QS™	
FAST®	Quiet Series™	
FAST _r ™	SuperSOT™-3	
GTO™	SuperSOT™-6	
HiSeC™	SuperSOT™-8	

DISCLAIMER

FAIRCHILD SEMICONDUCTOR RESERVES THE RIGHT TO MAKE CHANGES WITHOUT FURTHER NOTICE TO ANY PRODUCTS HEREIN TO IMPROVE RELIABILITY, FUNCTION OR DESIGN. FAIRCHILD DOES NOT ASSUME ANY LIABILITY ARISING OUT OF THE APPLICATION OR USE OF ANY PRODUCT OR CIRCUIT DESCRIBED HEREIN; NEITHER DOES IT CONVEY ANY LICENSE UNDER ITS PATENT RIGHTS, NOR THE RIGHTS OF OTHERS.

LIFE SUPPORT POLICY

FAIRCHILD'S PRODUCTS ARE NOT AUTHORIZED FOR USE AS CRITICAL COMPONENTS IN LIFE SUPPORT DEVICES OR SYSTEMS WITHOUT THE EXPRESS WRITTEN APPROVAL OF FAIRCHILD SEMICONDUCTOR CORPORATION.
As used herein:

1. Life support devices or systems are devices or systems which, (a) are intended for surgical implant into the body, or (b) support or sustain life, or (c) whose failure to perform when properly used in accordance with instructions for use provided in the labeling, can be reasonably expected to result in significant injury to the user.
2. A critical component is any component of a life support device or system whose failure to perform can be reasonably expected to cause the failure of the life support device or system, or to affect its safety or effectiveness.

PRODUCT STATUS DEFINITIONS

Definition of Terms

Datasheet Identification	Product Status	Definition
Advance Information	Formative or In Design	This datasheet contains the design specifications for product development. Specifications may change in any manner without notice.
Preliminary	First Production	This datasheet contains preliminary data, and supplementary data will be published at a later date. Fairchild Semiconductor reserves the right to make changes at any time without notice in order to improve design.
No Identification Needed	Full Production	This datasheet contains final specifications. Fairchild Semiconductor reserves the right to make changes at any time without notice in order to improve design.
Obsolete	Not In Production	This datasheet contains specifications on a product that has been discontinued by Fairchild semiconductor. The datasheet is printed for reference information only.