

# 2003 THRU 2024

Data Sheet  
29304F

## HIGH-VOLTAGE, HIGH-CURRENT DARLINGTON ARRAYS

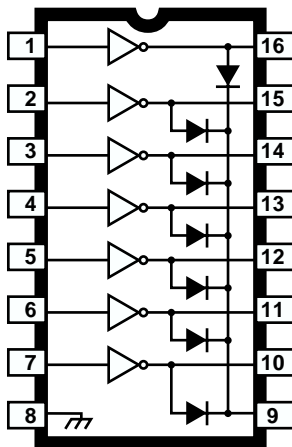

Dwg. No. A-9594

Note that the ULN20xxA series (dual in-line package) and ULN20xxL series (small-outline IC package) are electrically identical and share a common terminal number assignment.

### ABSOLUTE MAXIMUM RATINGS

Output Voltage, $V_{CE}$	
(ULN200xA and ULN200xL) .....	50 V
(ULN202xA and ULN202xL) .....	95 V
Input Voltage, $V_{IN}$ .....	30 V
Continuous Output Current,	
$I_C$ .....	500 mA
Continuous Input Current, $I_{IN}$ .....	25 mA
Power Dissipation, $P_D$	
(one Darlington pair) .....	1.0 W
(total package) .....	See Graph
Operating Temperature Range,	
$T_A$ .....	-20°C to +85°C
Storage Temperature Range,	
$T_S$ .....	-55°C to +150°C

Ideally suited for interfacing between low-level logic circuitry and multiple peripheral power loads, the Series ULN20xxA/L high-voltage, high-current Darlington arrays feature continuous load current ratings to 500 mA for each of the seven drivers. At an appropriate duty cycle depending on ambient temperature and number of drivers turned ON simultaneously, typical power loads totaling over 230 W (350 mA x 7, 95 V) can be controlled. Typical loads include relays, solenoids, stepping motors, magnetic print hammers, multiplexed LED and incandescent displays, and heaters. All devices feature open-collector outputs with integral clamp diodes.

The ULN2003A/L and ULN2023A/L have series input resistors selected for operation directly with 5 V TTL or CMOS. These devices will handle numerous interface needs — particularly those beyond the capabilities of standard logic buffers.

The ULN2004A/L and ULN2024A/L have series input resistors for operation directly from 6 to 15 V CMOS or PMOS logic outputs.

The ULN2003A/L and ULN2004A/L are the standard Darlington arrays. The outputs are capable of sinking 500 mA and will withstand at least 50 V in the OFF state. Outputs may be paralleled for higher load current capability. The ULN2023A/L and ULN2024A/L will withstand 95 V in the OFF state.

These Darlington arrays are furnished in 16-pin dual in-line plastic packages (suffix “A”) and 16-lead surface-mountable SOICs (suffix “L”). All devices are pinned with outputs opposite inputs to facilitate ease of circuit board layout. All devices are rated for operation over the temperature range of -20°C to +85°C. Most (see matrix, next page) are also available for operation to -40°C; to order, change the prefix from “ULN” to “ULQ”.

### FEATURES

- TTL, DTL, PMOS, or CMOS-Compatible Inputs
- Output Current to 500 mA
- Output Voltage to 95 V
- Transient-Protected Outputs
- Dual In-Line Plastic Package or Small-Outline IC Package

x = digit to identify specific device. Characteristic shown applies to family of devices with remaining digits as shown. See matrix on next page.

**2003 THRU 2024**  
**HIGH-VOLTAGE,**  
**HIGH-CURRENT**  
**DARLINGTON ARRAYS**

**DEVICE PART NUMBER DESIGNATION**

$V_{CE(MAX)}$	50 V	95 V
$I_{C(MAX)}$	500 mA	500 mA
<b>Logic</b>	<b>Part Number</b>	
5V TTL, CMOS	ULN2003A* ULN2003L*	ULN2023A* ULN2023L
6-15 V CMOS, PMOS	ULN2004A* ULN2004L*	ULN2024A ULN2024L

**PARTIAL SCHEMATICS**

**ULN20x3A/L (Each Driver)**

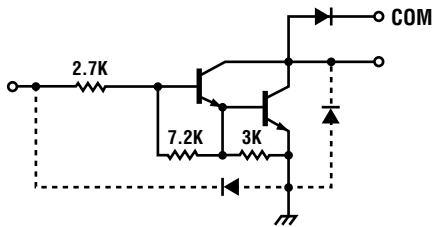

Dwg. No. A-9651

**ULN20x4A/L (Each Driver)**

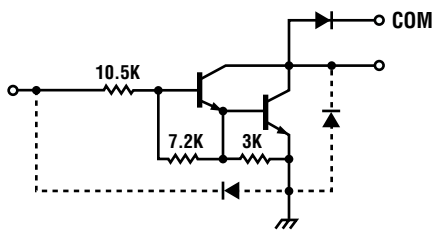

Dwg. No. A-9898A

\*Also available for operation between -40°C and +85°C. To order, change prefix from "ULN" to "ULQ".

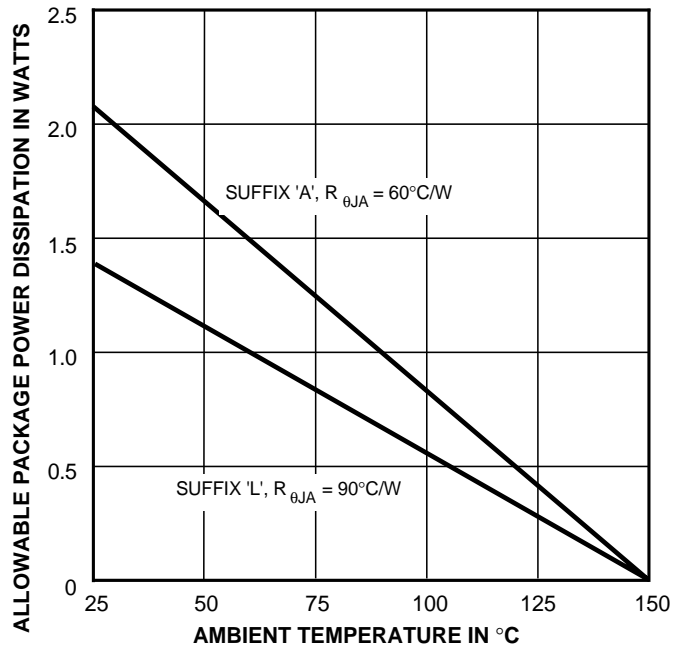

Dwg. GP-006A

X = Digit to identify specific device. Specification shown applies to family of devices with remaining digits as shown. See matrix above.



**2003 THRU 2024**  
**HIGH-VOLTAGE,**  
**HIGH-CURRENT**  
**DARLINGTON ARRAYS**

**Types ULN2003A, ULN2003L, ULN2004A, and ULN2004L**  
**ELECTRICAL CHARACTERISTICS at +25°C (unless otherwise noted).**

Characteristic	Symbol	Test Fig.	Applicable Devices	Test Conditions	Limits			
					Min.	Typ.	Max.	Units
Output Leakage Current	$I_{CEX}$	1A	All	$V_{CE} = 50\text{ V}, T_A = 25^\circ\text{C}$	—	< 1	50	$\mu\text{A}$
				$V_{CE} = 50\text{ V}, T_A = 70^\circ\text{C}$	—	< 1	100	$\mu\text{A}$
		1B	ULN2004A/L	$V_{CE} = 50\text{ V}, T_A = 70^\circ\text{C}, V_{IN} = 1.0\text{ V}$	—	< 5	500	$\mu\text{A}$
Collector-Emitter Saturation Voltage	$V_{CE(SAT)}$	2	All	$I_C = 100\text{ mA}, I_B = 250\text{ }\mu\text{A}$	—	0.9	1.1	V
				$I_C = 200\text{ mA}, I_B = 350\text{ }\mu\text{A}$	—	1.1	1.3	V
				$I_C = 350\text{ mA}, I_B = 500\text{ }\mu\text{A}$	—	1.3	1.6	V
Input Current	$I_{IN(ON)}$	3	ULN2003A/L	$V_{IN} = 3.85\text{ V}$	—	0.93	1.35	mA
			ULN2004A/L	$V_{IN} = 5.0\text{ V}$	—	0.35	0.5	mA
				$V_{IN} = 12\text{ V}$	—	1.0	1.45	mA
	$I_{IN(OFF)}$	4	All	$I_C = 500\text{ }\mu\text{A}, T_A = 70^\circ\text{C}$	50	65	—	$\mu\text{A}$
Input Voltage	$V_{IN(ON)}$	5	ULN2003A/L	$V_{CE} = 2.0\text{ V}, I_C = 200\text{ mA}$	—	—	2.4	V
				$V_{CE} = 2.0\text{ V}, I_C = 250\text{ mA}$	—	—	2.7	V
				$V_{CE} = 2.0\text{ V}, I_C = 300\text{ mA}$	—	—	3.0	V
		ULN2004A/L	$V_{CE} = 2.0\text{ V}, I_C = 125\text{ mA}$	—	—	5.0	V	
			$V_{CE} = 2.0\text{ V}, I_C = 200\text{ mA}$	—	—	6.0	V	
			$V_{CE} = 2.0\text{ V}, I_C = 275\text{ mA}$	—	—	7.0	V	
			$V_{CE} = 2.0\text{ V}, I_C = 350\text{ mA}$	—	—	8.0	V	
Input Capacitance	$C_{IN}$	—	All		—	15	25	pF
Turn-On Delay	$t_{PLH}$	8	All	$0.5 E_{IN}$ to $0.5 E_{OUT}$	—	0.25	1.0	$\mu\text{s}$
Turn-Off Delay	$t_{PHL}$	8	All	$0.5 E_{IN}$ to $0.5 E_{OUT}$	—	0.25	1.0	$\mu\text{s}$
Clamp Diode Leakage Current	$I_R$	6	All	$V_R = 50\text{ V}, T_A = 25^\circ\text{C}$	—	—	50	$\mu\text{A}$
				$V_R = 50\text{ V}, T_A = 70^\circ\text{C}$	—	—	100	$\mu\text{A}$
Clamp Diode Forward Voltage	$V_F$	7	All	$I_F = 350\text{ mA}$	—	1.7	2.0	V

Complete part number includes suffix to identify package style: A = DIP, L = SOIC.

**2003 THRU 2024**  
**HIGH-VOLTAGE,**  
**HIGH-CURRENT**  
**DARLINGTON ARRAYS**

**Types ULN2023A, ULN2023L, ULN2024A, and ULN2024L**  
**ELECTRICAL CHARACTERISTICS at +25°C (unless otherwise noted).**

Characteristic	Symbol	Test Fig.	Applicable Devices	Test Conditions	Limits			
					Min.	Typ.	Max.	Units
Output Leakage Current	$I_{CEX}$	1A	All	$V_{CE} = 95\text{ V}, T_A = 25^\circ\text{C}$	—	< 1	50	$\mu\text{A}$
				$V_{CE} = 95\text{ V}, T_A = 70^\circ\text{C}$	—	< 1	100	$\mu\text{A}$
		1B	ULN2024A/L	$V_{CE} = 95\text{ V}, T_A = 70^\circ\text{C}, V_{IN} = 1.0\text{ V}$	—	< 5	500	$\mu\text{A}$
Collector-Emitter Saturation Voltage	$V_{CE(SAT)}$	2	All	$I_C = 100\text{ mA}, I_B = 250\text{ }\mu\text{A}$	—	0.9	1.1	V
				$I_C = 200\text{ mA}, I_B = 350\text{ }\mu\text{A}$	—	1.1	1.3	V
				$I_C = 350\text{ mA}, I_B = 500\text{ }\mu\text{A}$	—	1.3	1.6	V
Input Current	$I_{IN(ON)}$	3	ULN2023A/L	$V_{IN} = 3.85\text{ V}$	—	0.93	1.35	mA
			ULN2024A/L	$V_{IN} = 5.0\text{ V}$	—	0.35	0.5	mA
				$V_{IN} = 12\text{ V}$	—	1.0	1.45	mA
	$I_{IN(OFF)}$	4	All	$I_C = 500\text{ }\mu\text{A}, T_A = 70^\circ\text{C}$	50	65	—	$\mu\text{A}$
Input Voltage	$V_{IN(ON)}$	5	ULN2023A/L	$V_{CE} = 2.0\text{ V}, I_C = 200\text{ mA}$	—	—	2.4	V
				$V_{CE} = 2.0\text{ V}, I_C = 250\text{ mA}$	—	—	2.7	V
				$V_{CE} = 2.0\text{ V}, I_C = 300\text{ mA}$	—	—	3.0	V
		ULN2024A/L	$V_{CE} = 2.0\text{ V}, I_C = 125\text{ mA}$	—	—	5.0	V	
			$V_{CE} = 2.0\text{ V}, I_C = 200\text{ mA}$	—	—	6.0	V	
			$V_{CE} = 2.0\text{ V}, I_C = 275\text{ mA}$	—	—	7.0	V	
			$V_{CE} = 2.0\text{ V}, I_C = 350\text{ mA}$	—	—	8.0	V	
Input Capacitance	$C_{IN}$	—	All		—	15	25	pF
Turn-On Delay	$t_{PLH}$	8	All	$0.5 E_{IN}$ to $0.5 E_{OUT}$	—	0.25	1.0	$\mu\text{s}$
Turn-Off Delay	$t_{PHL}$	8	All	$0.5 E_{IN}$ to $0.5 E_{OUT}$	—	0.25	1.0	$\mu\text{s}$
Clamp Diode Leakage Current	$I_R$	6	All	$V_R = 95\text{ V}, T_A = 25^\circ\text{C}$	—	—	50	$\mu\text{A}$
				$V_R = 95\text{ V}, T_A = 70^\circ\text{C}$	—	—	100	$\mu\text{A}$
Clamp Diode Forward Voltage	$V_F$	7	All	$I_F = 350\text{ mA}$	—	1.7	2.0	V

Complete part number includes suffix to identify package style: A = DIP, L = SOIC.



# 2003 THRU 2024 HIGH-VOLTAGE, HIGH-CURRENT DARLINGTON ARRAYS

## TEST FIGURES

**FIGURE 1A**

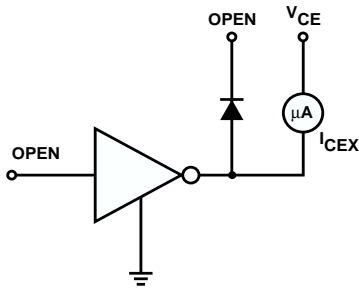

Dwg. No. A-9729A

**FIGURE 1B**

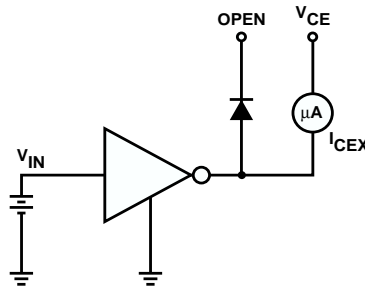

Dwg. No. A-9730A

**FIGURE 2**

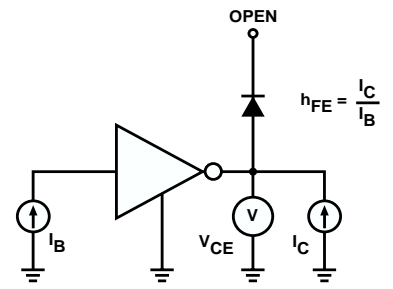

Dwg. No. A-9731A

**FIGURE 3**

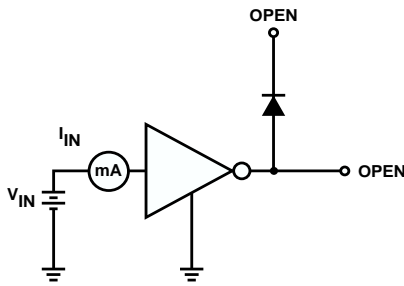

Dwg. No. A-9732A

**FIGURE 4**

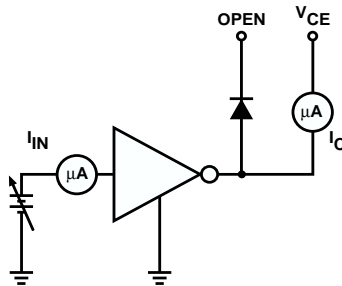

Dwg. No. A-9733A

**FIGURE 5**

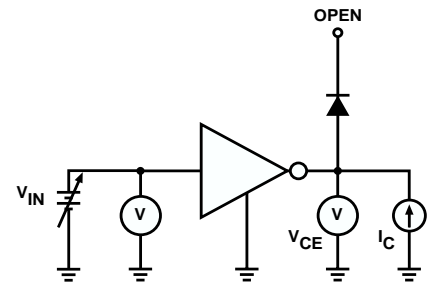

Dwg. No. A-9734A

**FIGURE 6**

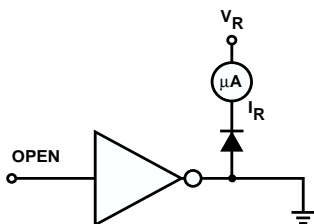

Dwg. No. A-9735A

**FIGURE 7**

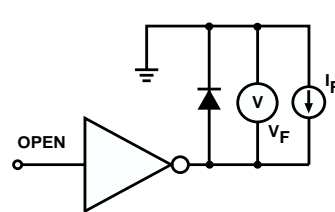

Dwg. No. A-9736A

**FIGURE 8**

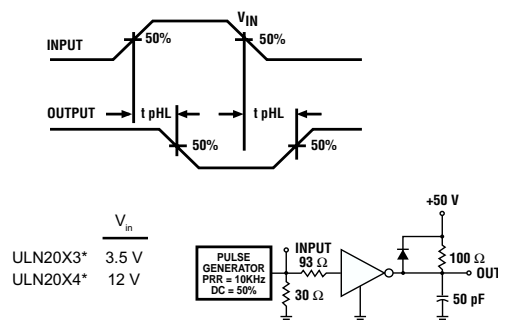

\* Complete part number includes a final letter to indicate package.

X = Digit to identify specific device. Specification shown applies to family of devices with remaining digits as shown.

# 2003 THRU 2024 HIGH-VOLTAGE, HIGH-CURRENT DARLINGTON ARRAYS

## ALLOWABLE COLLECTOR CURRENT AS A FUNCTION OF DUTY CYCLE (Dual In-line-Packaged Devices, Suffix 'A')

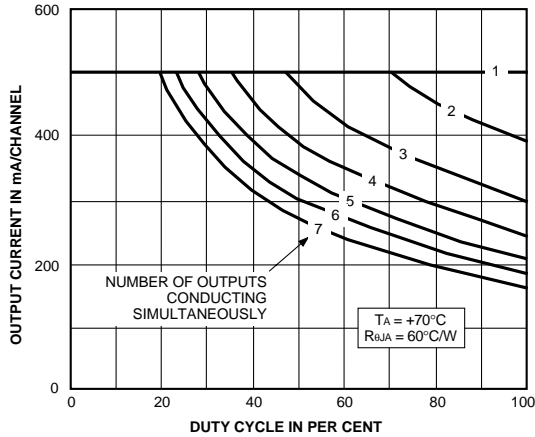

Dwg. GP-070

## (Small-Outline-Packaged Devices, Suffix 'L')

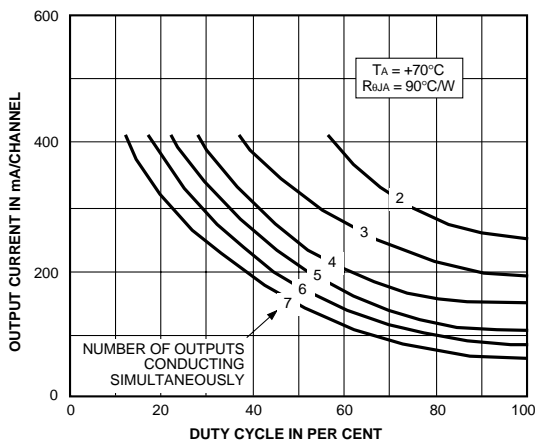

Dwg. GP-044A

## TYPICAL APPLICATIONS

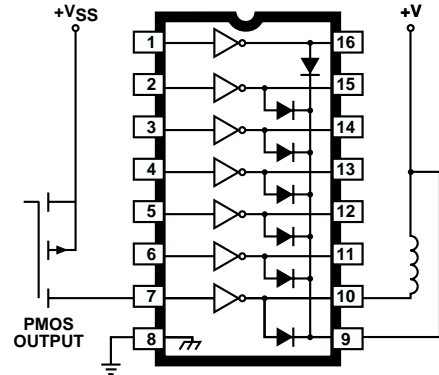

Dwg. No. A-9652

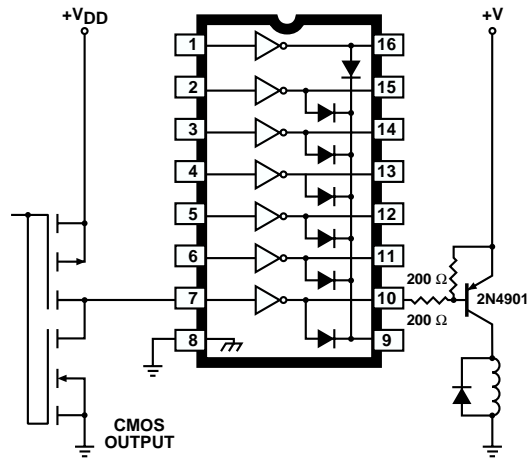

Dwg. No. A-9654A

## SATURATION VOLTAGE AS A FUNCTION OF COLLECTOR CURRENT

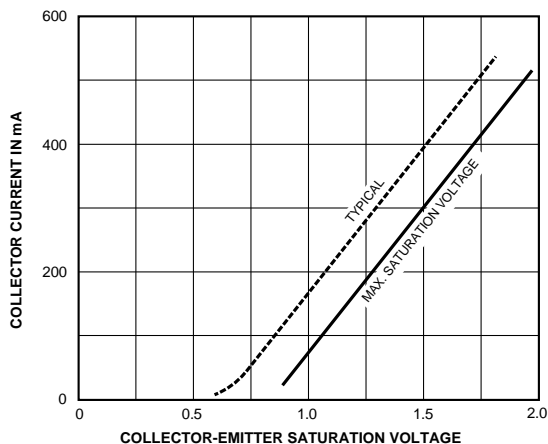

Dwg. GP-067

## COLLECTOR CURRENT AS A FUNCTION OF INPUT CURRENT

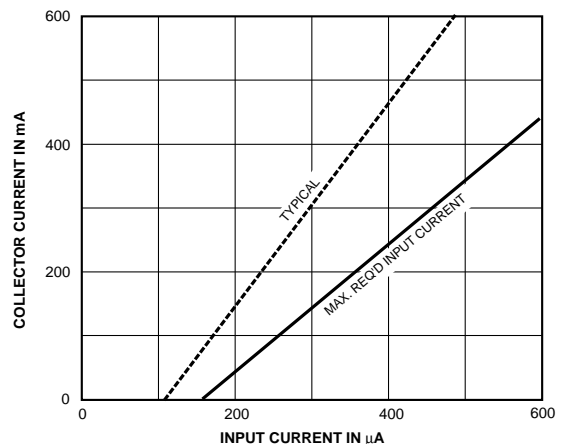

Dwg. GP-068

# 2003 THRU 2024 HIGH-VOLTAGE, HIGH-CURRENT DARLINGTON ARRAYS

## TYPICAL APPLICATIONS

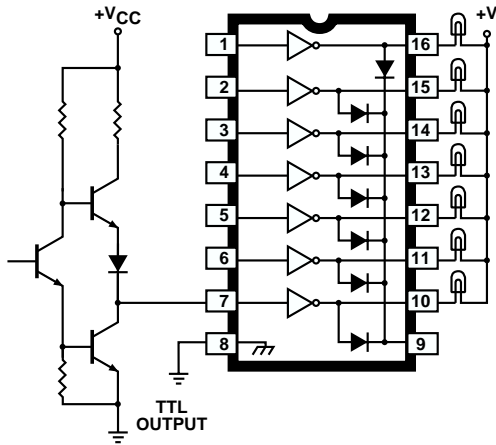

Dwg. No. A-9653A

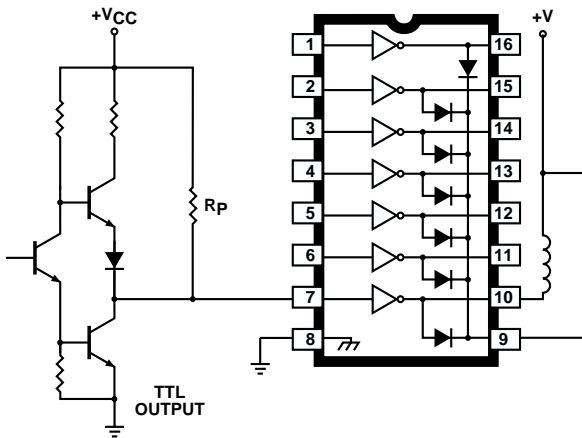

Dwg. No. A-10,175

## INPUT CURRENT AS A FUNCTION OF INPUT VOLTAGE

Types ULN2003A, ULN2003L, ULN2023A, and  
ULN2023L

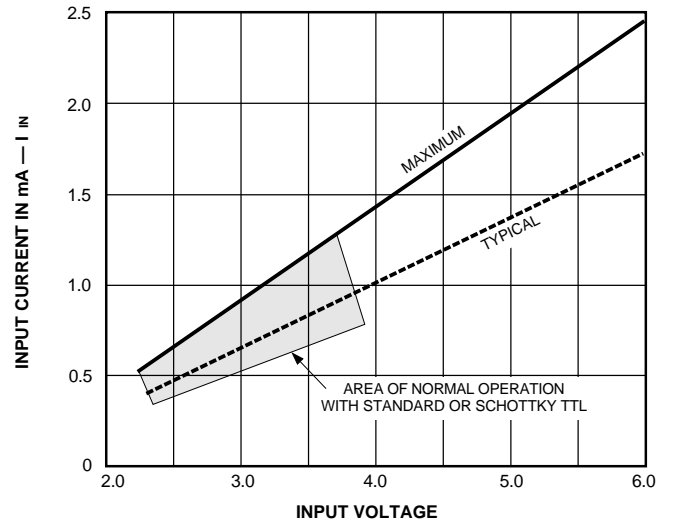

Dwg. GP-069

Types ULN2004A, ULN2004L, ULN2024A, and  
ULN2024L

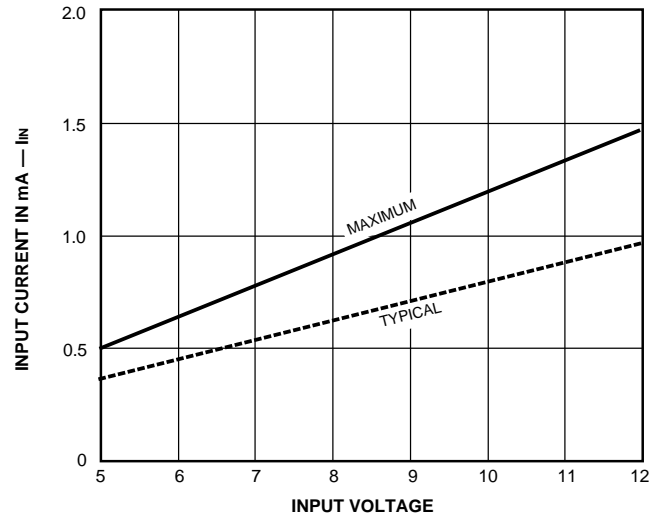

Dwg. GP-069-1

**2003 THRU 2024**  
**HIGH-VOLTAGE,**  
**HIGH-CURRENT**  
**DARLINGTON ARRAYS**

**PACKAGE DESIGNATOR "A"**

Dimensions in Inches  
 (controlling dimensions)

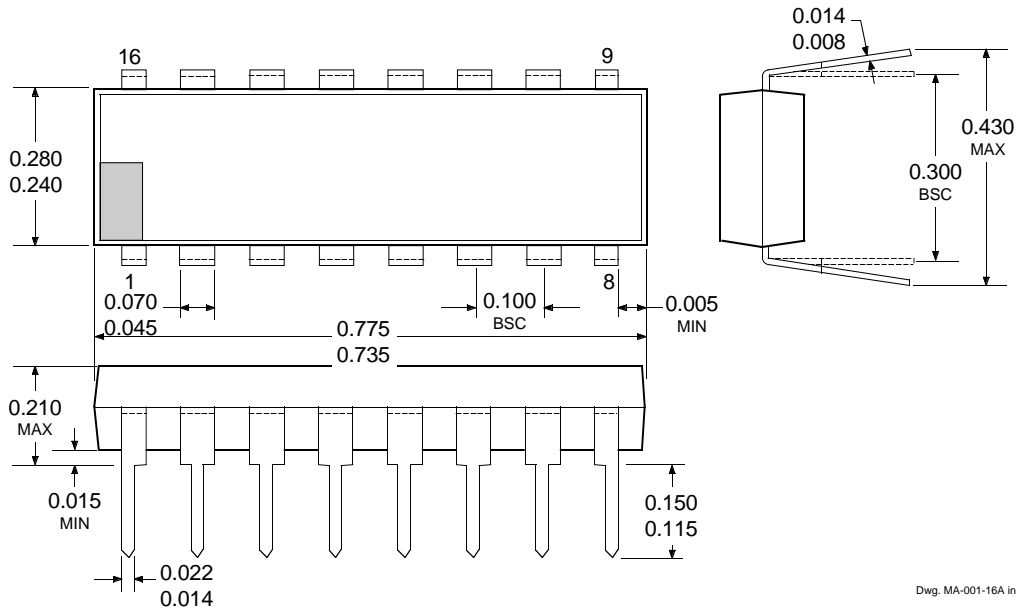

Dwg. MA-001-16A in

Dimension in Millimeters  
 (for reference only)

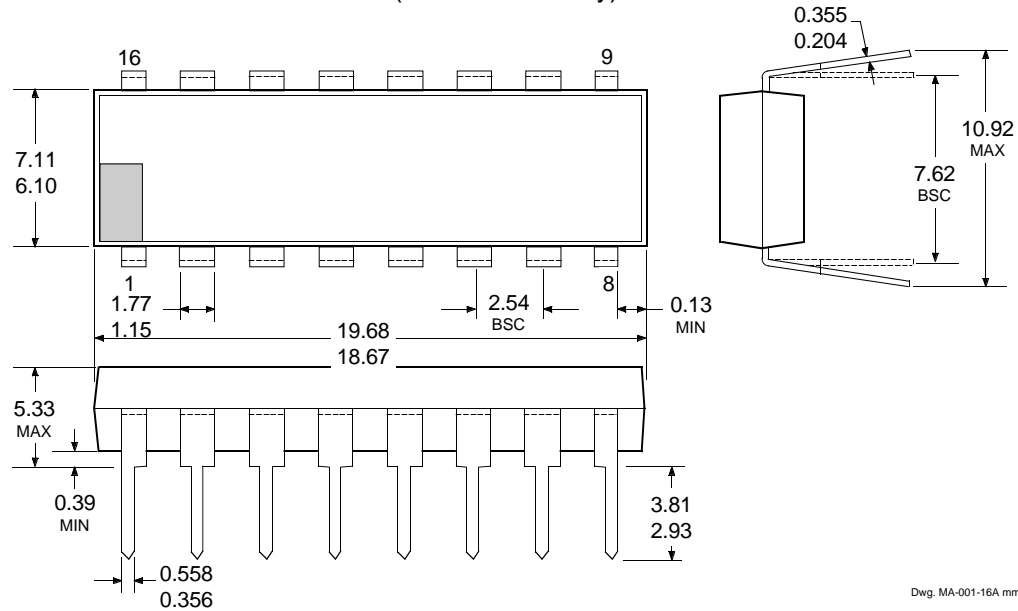

Dwg. MA-001-16A mm

- NOTES: 1. Leads 1, 8, 9, and 16 may be half leads at vendor's option.  
 2. Lead thickness is measured at seating plane or below.  
 3. Lead spacing tolerance is non-cumulative.  
 4. Exact body and lead configuration at vendor's option within limits shown.

**2003 THRU 2024**  
**HIGH-VOLTAGE,**  
**HIGH-CURRENT**  
**DARLINGTON ARRAYS**

**PACKAGE DESIGNATOR "L"**

Dimensions in Inches  
(for reference only)

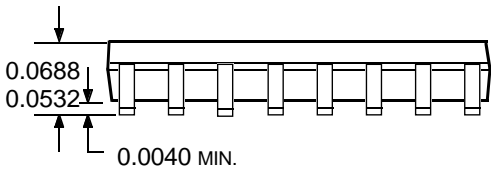
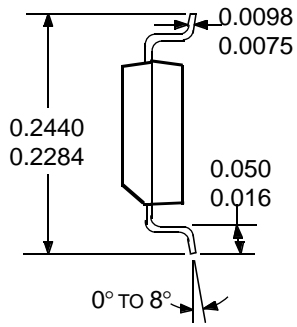
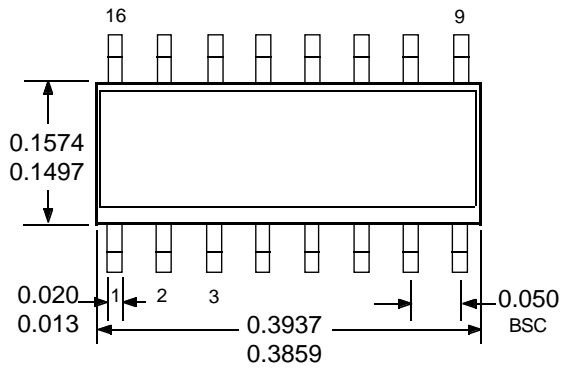

Dimension in Millimeters  
(controlling dimensions)

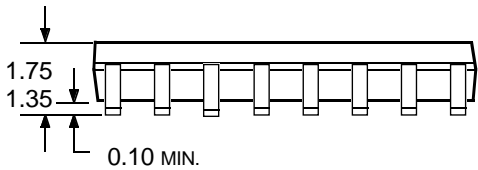
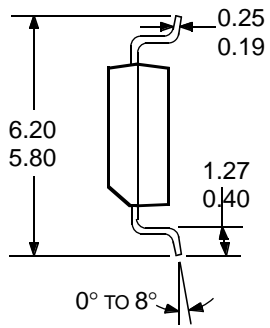
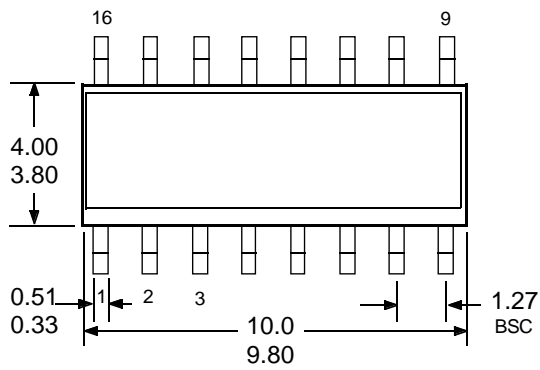

Dwg. MA-007-16 in

Dwg. MA-007-16A mm

- NOTES: 1. Lead spacing tolerance is non-cumulative.  
2. Exact body and lead configuration at vendor's option within limits shown.

**2003 THRU 2024**  
***HIGH-VOLTAGE,***  
***HIGH-CURRENT***  
***DARLINGTON ARRAYS***

*The products described here are manufactured under one or more U.S. patents or U.S. patents pending.*

*Allegro MicroSystems, Inc. reserves the right to make, from time to time, such departures from the detail specifications as may be required to permit improvements in the performance, reliability, or manufacturability of its products. Before placing an order, the user is cautioned to verify that the information being relied upon is current.*

*Allegro products are not authorized for use as critical components in life-support devices or systems without express written approval.*

*The information included herein is believed to be accurate and reliable. However, Allegro MicroSystems, Inc. assumes no responsibility for its use; nor for any infringement of patents or other rights of third parties which may result from its use.*

