

## LOW POWER DUAL J-FET OPERATIONAL AMPLIFIERS

- VERY LOW POWER CONSUMPTION :
- WIDE COMMON-MODE (UP TO  $V_{CC}^+$ ) AND DIFFERENTIAL VOLTAGE RANGES
- LOW INPUT BIAS AND OFFSET CURRENTS
- TYPICAL SUPPLY CURRENT : 200 $\mu$ A
- OUTPUT SHORT-CIRCUIT PROTECTION
- HIGH INPUT IMPEDANCE J-FET INPUT STAGE
- INTERNAL FREQUENCY COMPENSATION
- LATCH UP FREE OPERATION
- HIGH SLEW RATE : 3.5V/ $\mu$ s (TYP)

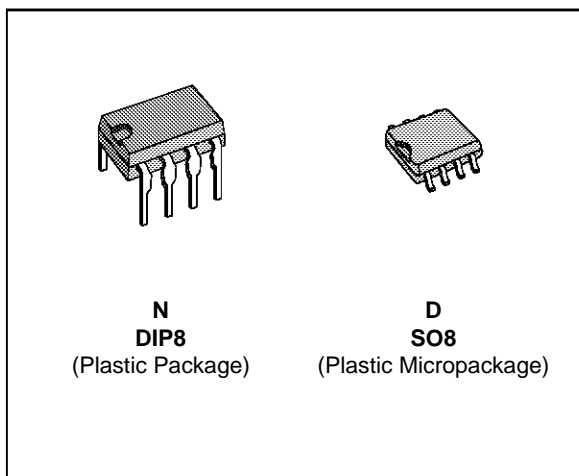

### DESCRIPTION

The TL062, TL062A and TL062B are high speed J-FET input dual operational amplifier family. Each of these J-FET input operational amplifiers incorporates well matched, high voltage J-FET and bipolar transistors in a monolithic integrated circuit. The devices feature high slew rates, low input bias and offset currents, and low offset voltage temperature coefficient.

### ORDER CODES

Part Number	Temperature Range	Package	
		N	D
TL062M/AM/BM	-55°C, +125°C	●	●
TL062I/AI/BI	-40°C, +105°C	●	●
TL062C/AC/BC	0°C, +70°C	●	●
<b>Example</b> : TL062IN			

062-01.TBL

### PIN CONNECTIONS (top view)

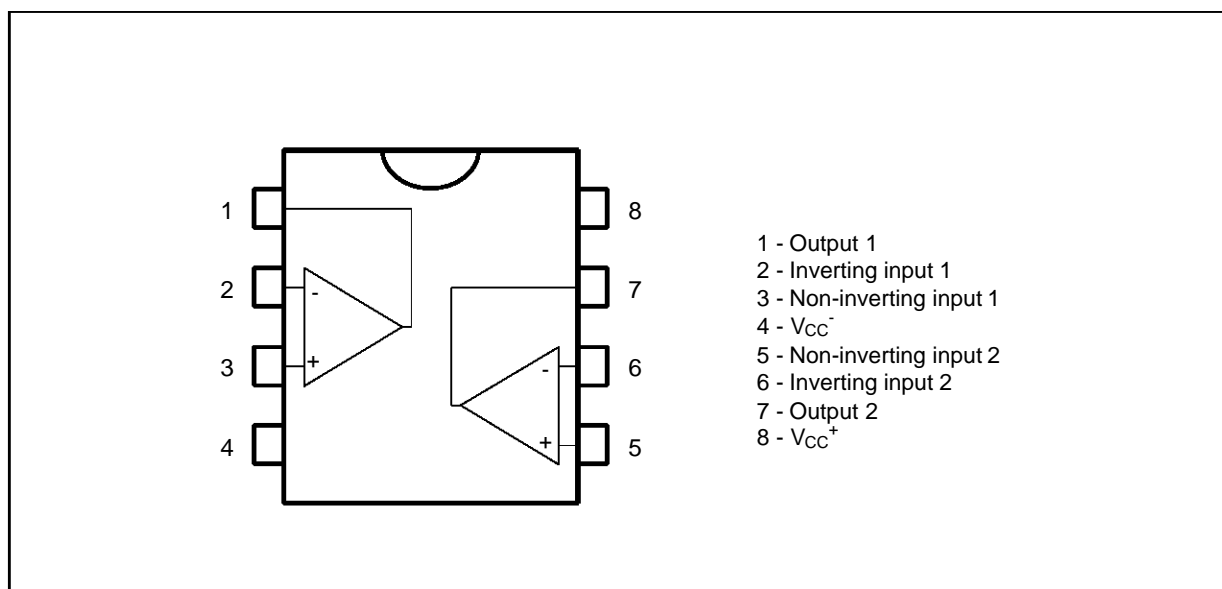

**SCHEMATIC DIAGRAM**

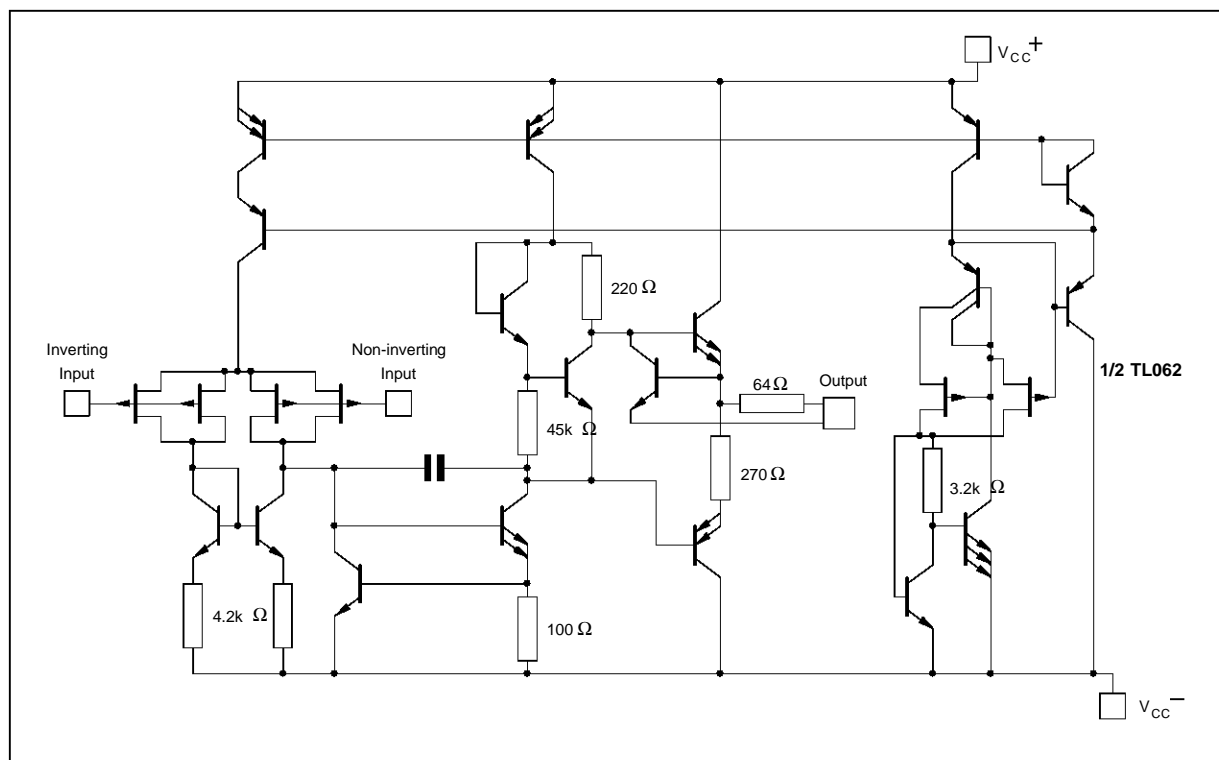

062-03.EPS

**MAXIMUM RATINGS**

Symbol	Parameter	TL062M,AM,BM	TL062I,AI,BI	TL062C,AC,BC	Unit
V <sub>CC</sub>	Supply Voltage - (note 1)	±18	±18	±18	V
V <sub>i</sub>	Input Voltage - (note 3)	±15	±15	±15	V
V <sub>id</sub>	Differential Input Voltage - (note 2)	±30	±30	±30	V
P <sub>tot</sub>	Power Dissipation	680	680	680	mW
	Output Short-Circuit Duration (Note 4)	Infinite	Infinite	Infinite	
T <sub>oper</sub>	Operating Free-Air Temperature Range	-55 to +125	-40 to +105	0 to +70	°C
T <sub>stg</sub>	Storage Temperature Range	- 65 to + 150	- 65 to + 150	- 65 to + 150	°C

062-02.TBL

- Notes :**
1. All voltage values, except differential voltage, are with respect to the zero reference level (ground) of the supply voltages where the zero reference level is the midpoint between V<sub>CC</sub><sup>+</sup> and V<sub>CC</sub><sup>-</sup>.
  2. Differential voltages are at the non-inverting input terminal with respect to the inverting input terminal.
  3. The magnitude of the input voltage must never exceed the magnitude of the supply voltage or 15 volts, whichever is less.
  4. The output may be shorted to ground or to either supply. Temperature and/or supply voltages must be limited to ensure that the dissipation rating is not exceeded.

**ELECTRICAL CHARACTERISTICS**

$V_{CC} = \pm 15V$ ,  $T_{amb} = 25^{\circ}C$  (unless otherwise specified)

Symbol	Parameter	TL062M			TL062I			TL062C			Unit
		Min.	Typ.	Max.	Min.	Typ.	Max.	Min.	Typ.	Max.	
$V_{io}$	Input Offset Voltage ( $R_S = 50\Omega$ ) $T_{amb} = 25^{\circ}C$ $T_{min.} \leq T_{amb} \leq T_{max.}$		3	6 15		3	6 9		3	15 20	mV
$DV_{io}$	Temperature Coefficient of Input Offset Voltage ( $R_S = 50\Omega$ )		10			10			10		$\mu V/^{\circ}C$
$I_{io}$	Input Offset Current * $T_{amb} = 25^{\circ}C$ $T_{min.} \leq T_{amb} \leq T_{max.}$		5	100 20		5	100 10		5	200 5	pA nA
$I_{ib}$	Input Bias Current * $T_{amb} = 25^{\circ}C$ $T_{min.} \leq T_{amb} \leq T_{max.}$		30	200 50		30	200 20		30	400 10	pA nA
$V_{icm}$	Input Common Mode Voltage Range	$\pm 11.5$	+15 -12		$\pm 11.5$	+15 -12		$\pm 11$	+15 -12		V
$V_{OPP}$	Output Voltage Swing ( $R_L = 10k\Omega$ ) $T_{amb} = 25^{\circ}C$ $T_{min.} \leq T_{amb} \leq T_{max.}$	20 20	27		20 20	27		20 20	27		V
$A_{vd}$	Large Signal Voltage Gain ( $R_L = 10k\Omega$ , $V_o = \pm 10V$ ) $T_{amb} = 25^{\circ}C$ $T_{min.} \leq T_{amb} \leq T_{max.}$	4 4	6		4 4	6		3 3	6		V/mV
GBP	Gain Bandwidth Product ( $T_{amb} = 25^{\circ}C$ , $R_L = 10k\Omega$ $C_L = 100pF$ )		1			1			1		MHz
$R_i$	Input Resistance		$10^{12}$			$10^{12}$			$10^{12}$		$\Omega$
CMR	Common Mode Rejection Ratio ( $R_S = 50\Omega$ )	80	86		80	86		70	76		dB
SVR	Supply Voltage Rejection Ratio ( $R_S = 50\Omega$ )	80	95		80	95		70	95		dB
$I_{cc}$	Supply Current (Per Amplifier) ( $T_{amb} = 25^{\circ}C$ , no load, no signal)		200	250		200	250		200	250	$\mu A$
$V_{O1}/V_{O2}$	Channel Separation ( $A_V = 100$ , $T_{amb} = 25^{\circ}C$ )		120			120			120		dB
$P_D$	Total Power Consumption (Each Amplifier) ( $T_{amb} = 25^{\circ}C$ , no load, no signal)		6	7.5		6	7.5		6	7.5	mW

\* Input bias currents of a FET-input operational amplifier are normal junction reverse currents, which are temperature sensitive. Pulse techniques must be used that will maintain the junction temperature as close to the ambient temperature as possible.

**ELECTRICAL CHARACTERISTICS (continued)**

$V_{CC} = \pm 15V$ ,  $T_{amb} = 25^{\circ}C$

Symbol	Parameter	TL062C,I,M			Unit
		Min.	Typ.	Max.	
SR	Slew Rate ( $V_i = 10V$ , $R_L = 10k\Omega$ , $C_L = 100pF$ , $A_V = 1$ )	1.5	3.5		$V/\mu s$
$t_r$	Rise Time ( $V_i = 20mV$ , $R_L = 10k\Omega$ , $C_L = 100pF$ , $A_V = 1$ )		0.2		$\mu s$
$K_{OV}$	Overshoot Factor ( $V_i = 20mV$ , $R_L = 10k\Omega$ , $C_L = 100pF$ , $A_V = 1$ ) (see figure 1)		10		%
$e_n$	Equivalent Input Noise Voltage ( $R_S = 100\Omega$ , $f = 1KHz$ )		42		$\frac{nV}{\sqrt{Hz}}$

## TL062 - TL062A - TL062B

### ELECTRICAL CHARACTERISTICS (continued)

$V_{CC} = \pm 15V$ ,  $T_{amb} = 25^{\circ}C$  (unless otherwise specified)

Symbol	Parameter	TL062AC,AI, AM			TL062BC,BI,BM			Unit
		Min.	Typ.	Max.	Min.	Typ.	Max.	
$V_{io}$	Input Offset Voltage ( $R_s = 50\Omega$ ) $T_{amb} = 25^{\circ}C$ $T_{min.} \leq T_{amb} \leq T_{max.}$		3	6 7.5		2	3 5	mV
$DV_{io}$	Temperature Coefficient of Input Offset Voltage ( $R_s = 50\Omega$ )		10			10		$\mu V/^{\circ}C$
$I_{io}$	Input Offset Current * $T_{amb} = 25^{\circ}C$ $T_{min.} \leq T_{amb} \leq T_{max.}$		5	100 3		5	100 3	pA nA
$I_{ib}$	Input Bias Current * $T_{amb} = 25^{\circ}C$ $T_{min.} \leq T_{amb} \leq T_{max.}$		30	200 7		30	200 7	pA nA
$V_{icm}$	Input Common Mode Voltage Range	$\pm 11.5$	+15 -12		$\pm 11.5$	+15 -12		V
$V_{OPP}$	Output Voltage Swing ( $R_L = 10k\Omega$ ) $T_{amb} = 25^{\circ}C$ $T_{min.} \leq T_{amb} \leq T_{max.}$	20 20	27		20 20	27		V
$A_{vd}$	Large Signal Voltage Gain ( $R_L = 10k\Omega$ , $V_o = \pm 10V$ ) $T_{amb} = 25^{\circ}C$ $T_{min.} \leq T_{amb} \leq T_{max.}$	4 4	6		4 4	6		V/mV
GBP	Gain Bandwidth Product ( $T_{amb} = 25^{\circ}C$ , $R_L = 10k\Omega$ , $C_L = 100pF$ )		1			1		MHz
$R_i$	Input Resistance		$10^{12}$			$10^{12}$		$\Omega$
CMR	Common Mode Rejection Ratio ( $R_s = 50\Omega$ )	80	86		80	86		dB
SVR	Supply Voltage Rejection Ratio ( $R_s = 50\Omega$ )	80	95		80	95		dB
$I_{cc}$	Supply Current (Per Amplifier) ( $T_{amb} = 25^{\circ}C$ , no load, no signal)		200	250		200	250	$\mu A$
$V_{O1}/V_{O2}$	Channel Separation ( $A_v = 100$ , $T_{amb} = 25^{\circ}C$ )		120			120		
$P_D$	Total Power Consumption (Each Amplifier) ( $T_{amb} = 25^{\circ}C$ , no load, no signal)		6	7.5		6	7.5	mW
SR	Slew Rate ( $V_i = 10V$ , $R_L = 10k\Omega$ , $C_L = 100pF$ , $A_v = 1$ )	1.5	3.5		1.5	3.5		V/ $\mu s$
$t_r$	Rise Time ( $V_i = 20mV$ , $R_L = 10k\Omega$ , $C_L = 100pF$ , $A_v = 1$ )		0.2			0.2		$\mu s$
KOV	Overshoot Factor ( $V_i = 20mV$ , $R_L = 10k\Omega$ , $C_L = 100pF$ , $A_v = 1$ ) - (see figure 1)		10			10		%
$e_n$	Equivalent Input Noise Voltage ( $R_s = 100\Omega$ , $f = 1KHz$ )		42			42		$\frac{nV}{\sqrt{Hz}}$

\* The input bias currents of a FET-input operational amplifier are normal junction reverse currents, which are temperature sensitive. Pulse techniques must be used that will maintain the junction temperature as close to the ambient temperature as possible.

062-05-TBL

**MAXIMUM PEAK-TO-PEAK OUTPUT VOLTAGE VERSUS SUPPLY VOLTAGE**

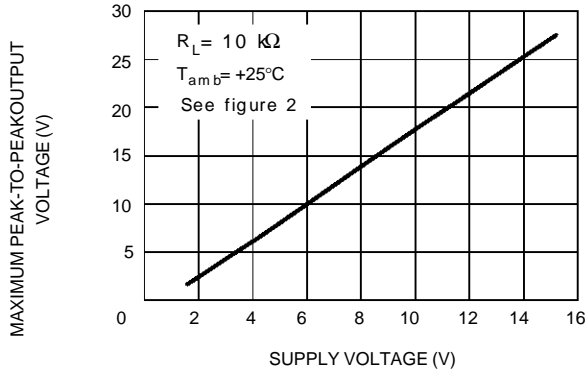

062-04.EPS

**MAXIMUM PEAK-TO-PEAK OUTPUT VOLTAGE VERSUS FREE AIR TEMP.**

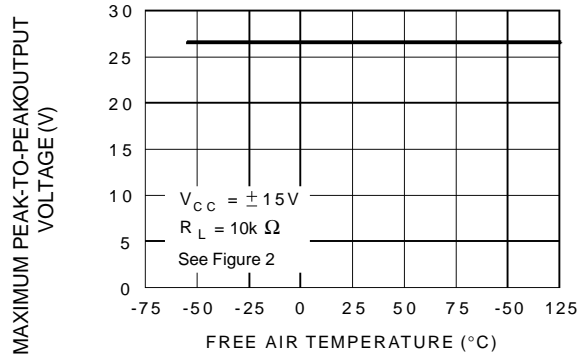

062-05.EPS

**MAXIMUM PEAK-TO-PEAK OUTPUT VOLTAGE VERSUS LOAD RESISTANCE**

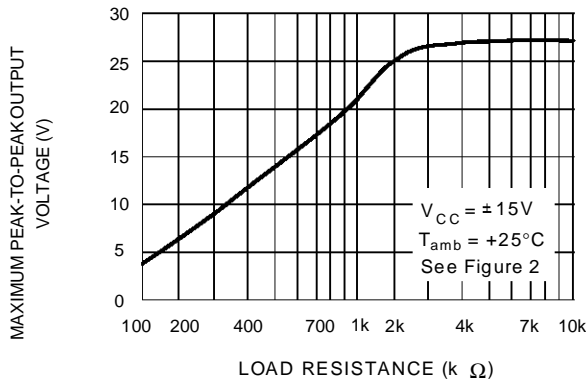

062-06.EPS

**MAXIMUM PEAK-TO-PEAK OUTPUT VOLTAGE VERSUS FREQUENCY**

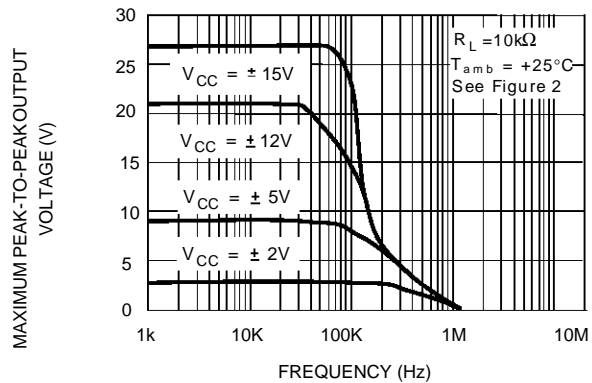

062-07.EPS

**DIFFERENTIAL VOLTAGE AMPLIFICATION VERSUS FREE AIR TEMPERATURE**

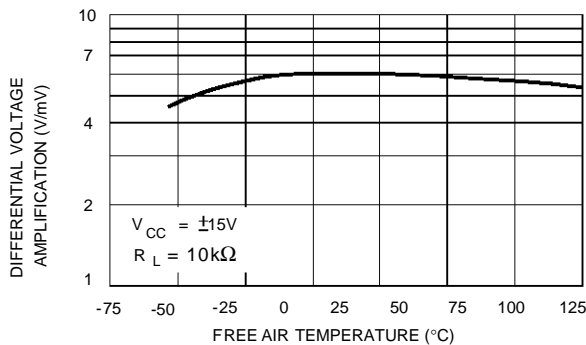

062-08.EPS

**LARGE SIGNAL DIFFERENTIAL VOLTAGE AMPLIFICATION AND PHASE SHIFT VERSUS FREQUENCY**

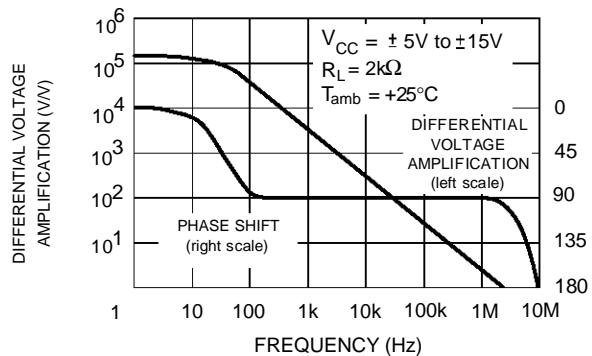

062-09.EPS

**SUPPLY CURRENT PER AMPLIFIER VERSUS SUPPLY VOLTAGE**

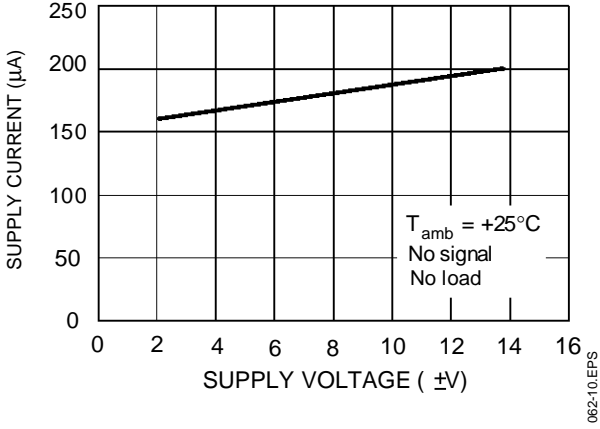

**SUPPLY CURRENT PER AMPLIFIER VERSUS FREE AIR TEMPERATURE**

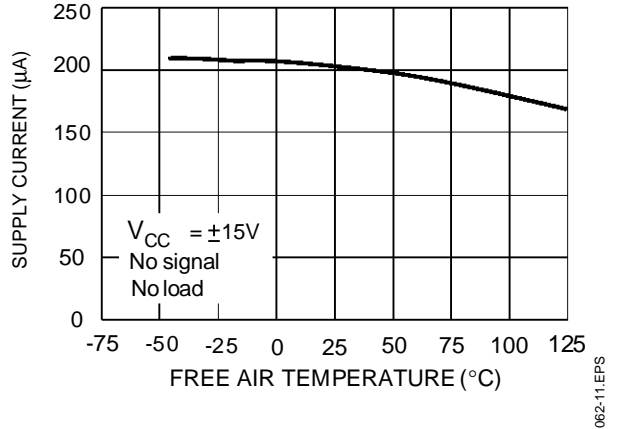

**TOTAL POWER DISSIPATED VERSUS FREE AIR TEMPERATURE**

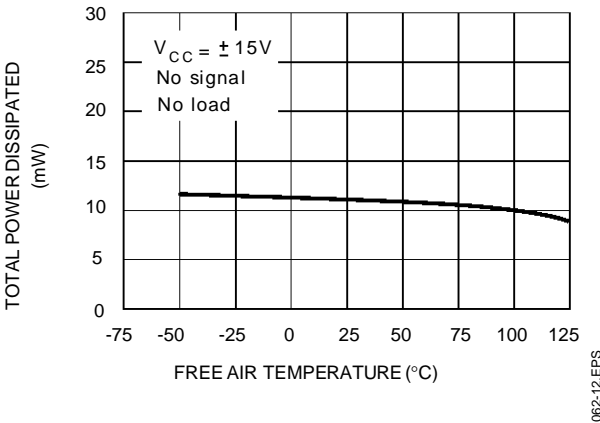

**COMMON MODE REJECTION RATIO VERSUS FREE AIR TEMPERATURE**

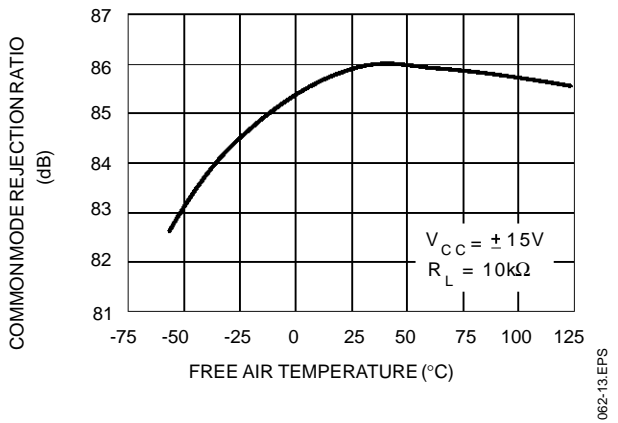

**NORMALIZED UNITY GAIN BANDWIDTH, SLEW RATE, AND PHASE SHIFT VERSUS TEMPERATURE**

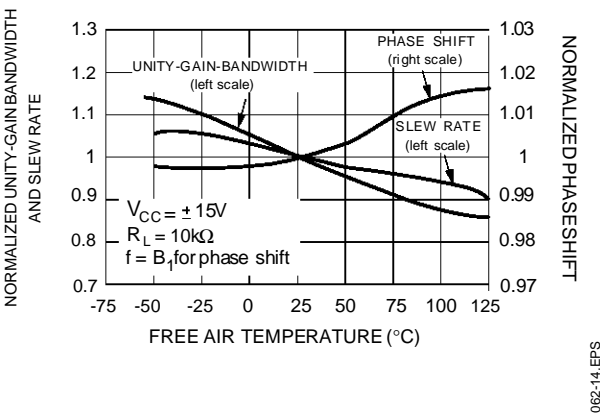

**INPUT BIAS CURRENT VERSUS FREE AIR TEMPERATURE**

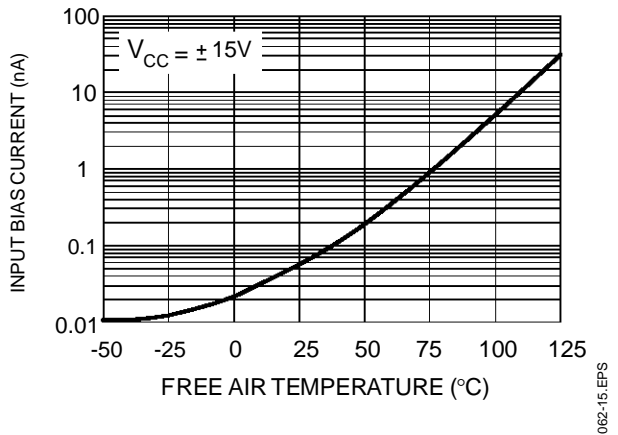

VOLTAGE FOLLOWER LARGE SIGNAL PULSE RESPONSE

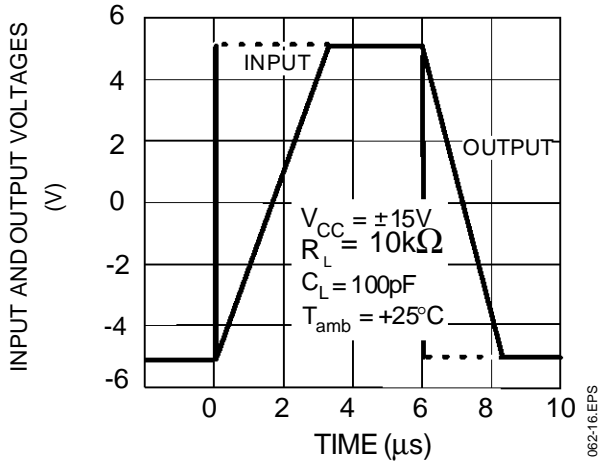

OUTPUT VOLTAGE VERSUS ELAPSED TIME

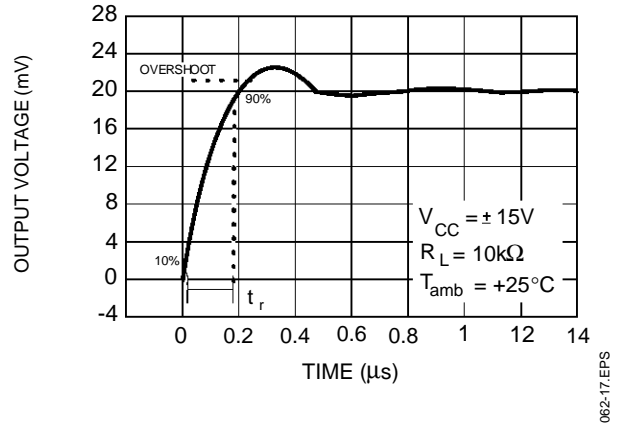

EQUIVALENT INPUT NOISE VOLTAGE VERSUS FREQUENCY

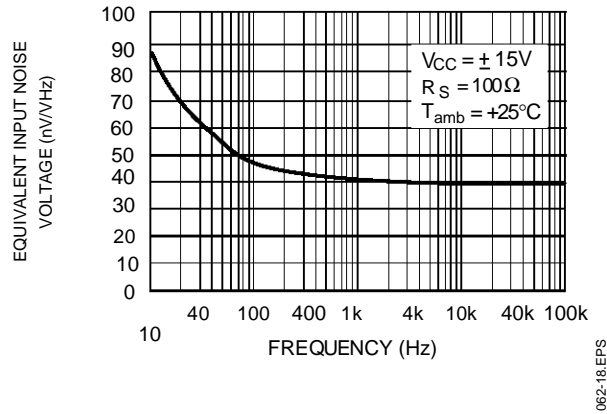

PARAMETER MEASUREMENT INFORMATION

Figure 1 : Voltage follower

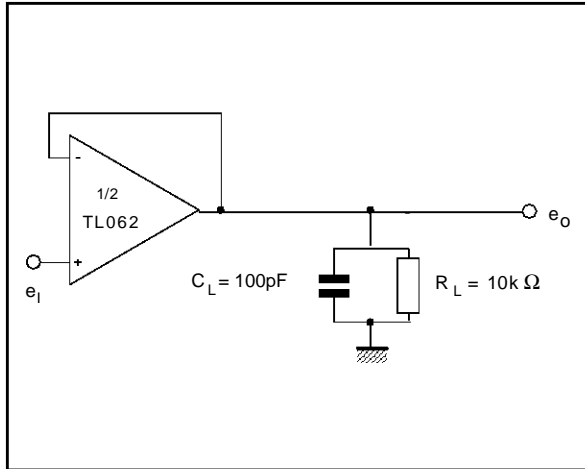

062-19.EPS

Figure 2 : Gain-of-10 inverting amplifier

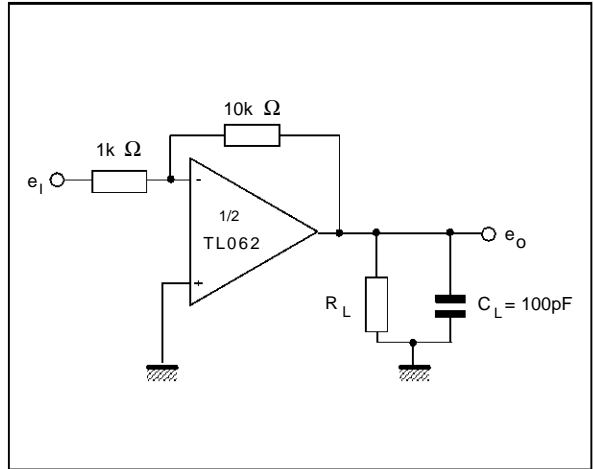

062-20.EPS

TYPICAL APPLICATION

100KHz QUADRATURE OSCILLATOR

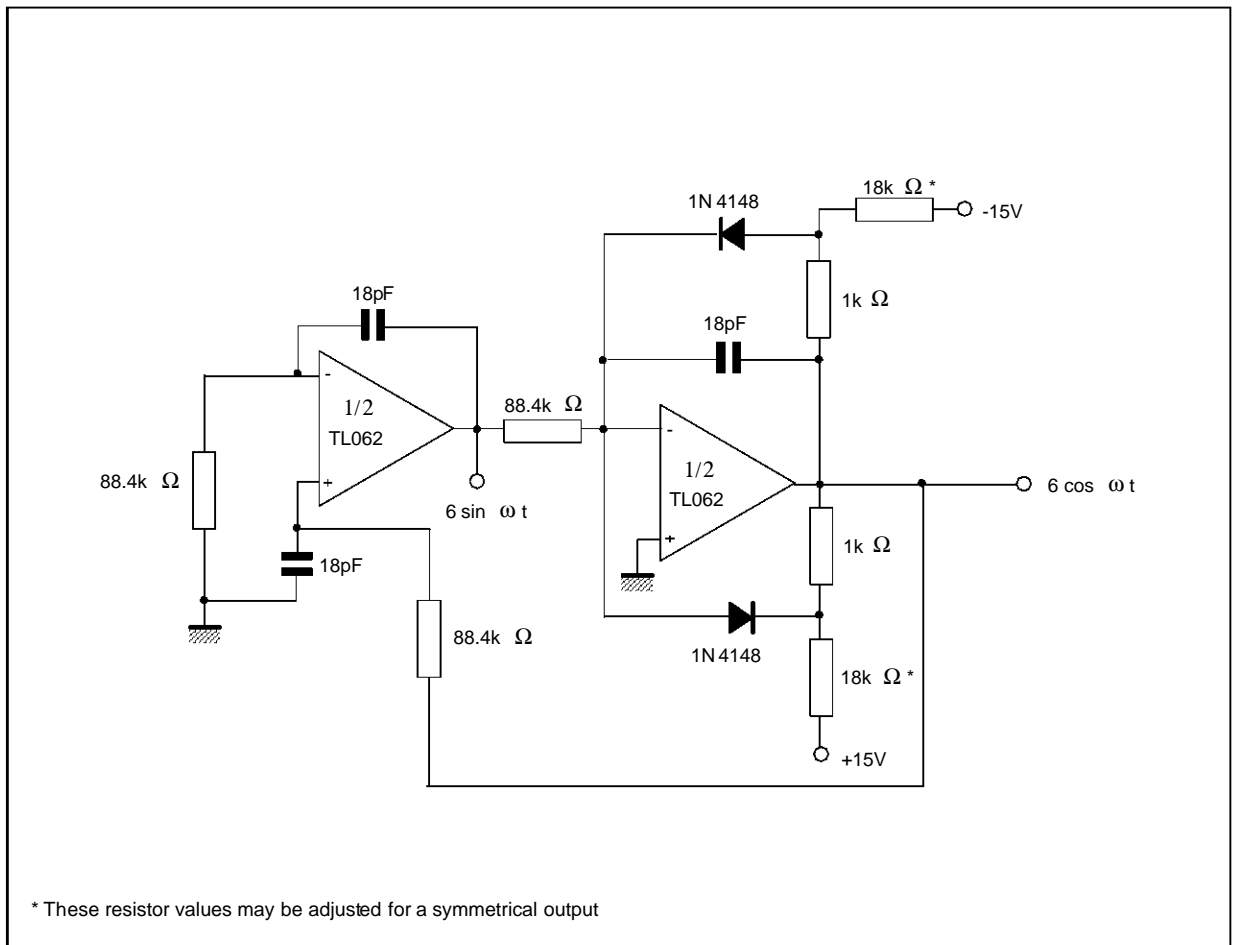

062-21.EPS

**PACKAGE MECHANICAL DATA**

8 PINS - PLASTIC DIP

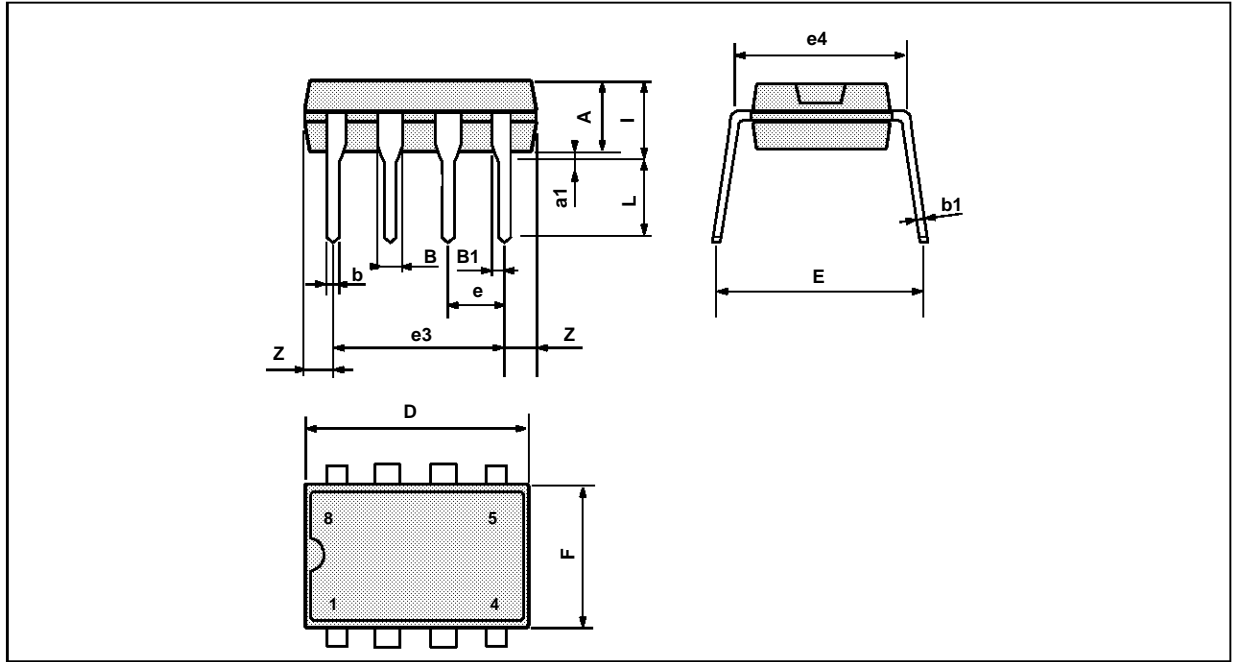

PM-DIP8.EPS

Dimensions	Millimeters			Inches		
	Min.	Typ.	Max.	Min.	Typ.	Max.
A		3.32			0.131	
a1	0.51			0.020		
B	1.15		1.65	0.045		0.065
b	0.356		0.55	0.014		0.022
b1	0.204		0.304	0.008		0.012
D			10.92			0.430
E	7.95		9.75	0.313		0.384
e		2.54			0.100	
e3		7.62			0.300	
e4		7.62			0.300	
F			6.6			0.260
i			5.08			0.200
L	3.18		3.81	0.125		0.150
Z			1.52			0.060

DIP8.TBL

# TL062 - TL062A - TL062B

## PACKAGE MECHANICAL DATA 8 PINS - PLASTIC MICROPACKAGE (SO)

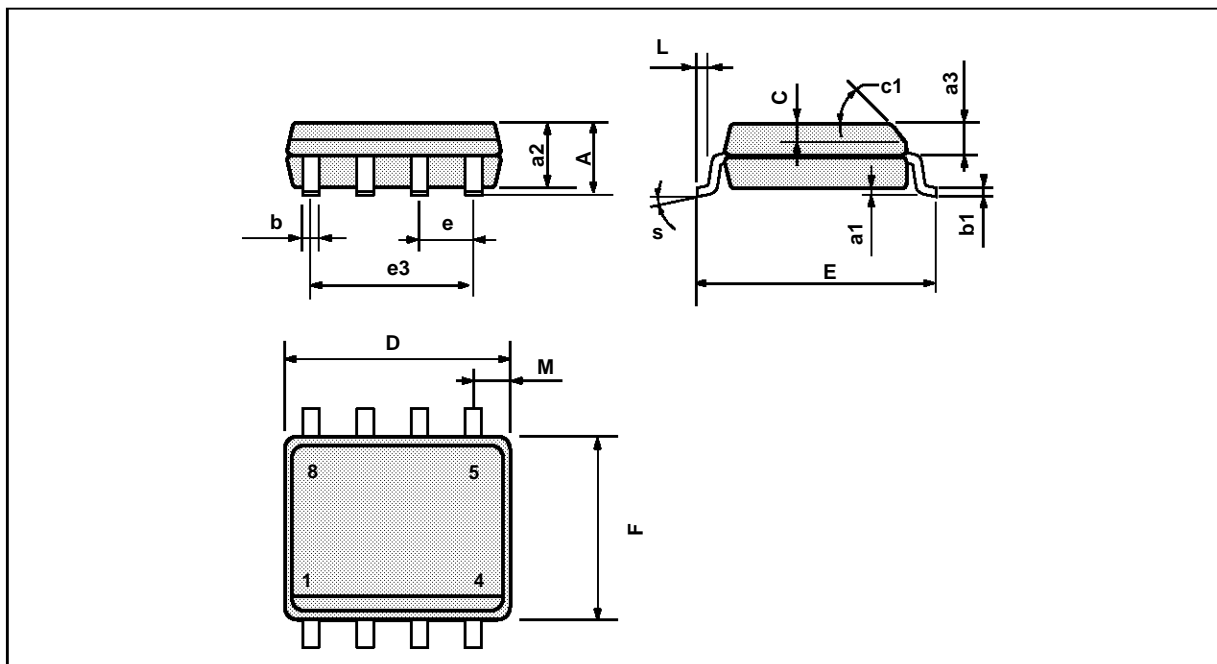

PM-S08.EPS

Dimensions	Millimeters			Inches		
	Min.	Typ.	Max.	Min.	Typ.	Max.
A			1.75			0.069
a1	0.1		0.25	0.004		0.010
a2			1.65			0.065
a3	0.65		0.85	0.026		0.033
b	0.35		0.48	0.014		0.019
b1	0.19		0.25	0.007		0.010
C	0.25		0.5	0.010		0.020
c1	45° (typ.)					
D	4.8		5.0	0.189		0.197
E	5.8		6.2	0.228		0.244
e		1.27			0.050	
e3		3.81			0.150	
F	3.8		4.0	0.150		0.157
L	0.4		1.27	0.016		0.050
M			0.6			0.024
S	8° (max.)					

S08.TBL

Information furnished is believed to be accurate and reliable. However, SGS-THOMSON Microelectronics assumes no responsibility for the consequences of use of such information nor for any infringement of patents or other rights of third parties which may result from its use. No licence is granted by implication or otherwise under any patent or patent rights of SGS-THOMSON Microelectronics. Specifications mentioned in this publication are subject to change without notice. This publication supersedes and replaces all information previously supplied. SGS-THOMSON Microelectronics products are not authorized for use as critical components in life support devices or systems without express written approval of SGS-THOMSON Microelectronics.

© 1995 SGS-THOMSON Microelectronics - All Rights Reserved

SGS-THOMSON Microelectronics GROUP OF COMPANIES

Australia - Brazil - France - Germany - Hong Kong - Italy - Japan - Korea - Malaysia - Malta - Morocco - The Netherlands  
Singapore - Spain - Sweden - Switzerland - Taiwan - Thailand - United Kingdom - U.S.A.

ORDER CODE :