



**USE ULTRA37000™ FOR
ALL NEW DESIGNS**

CY7C344B

32-Macrocell MAX® EPLD

Features

- High-performance, high-density replacement for TTL, 74HC, and custom logic
- 32 macrocells, 64 expander product terms in one LAB
- 8 dedicated inputs, 16 I/O pins
- 0.8-micron double-metal CMOS EPROM technology
- 28-pin, 300-mil DIP, cerDIP or 28-pin HLCC, PLCC package

Functional Description

Available in a 28-pin, 300-mil DIP or windowed J-leaded ceramic chip carrier (HLCC), the CY7C344 represents the

densest EPLD of this size. Eight dedicated inputs and 16 bidirectional I/O pins communicate to one logic array block. In the CY7C344 LAB there are 32 macrocells and 64 expander product terms. When an I/O macrocell is used as an input, two expanders are used to create an input path. Even if all of the I/O pins are driven by macrocell registers, there are still 16 “buried” registers available. All inputs, macrocells, and I/O pins are interconnected within the LAB.

The speed and density of the CY7C344 makes it a natural for all types of applications. With just this one device, the designer can implement complex state machines, registered logic, and combinatorial “glue” logic, without using multiple chips. This architectural flexibility allows the CY7C344 to replace multichip TTL solutions, whether they are synchronous, asynchronous, combinatorial, or all three.

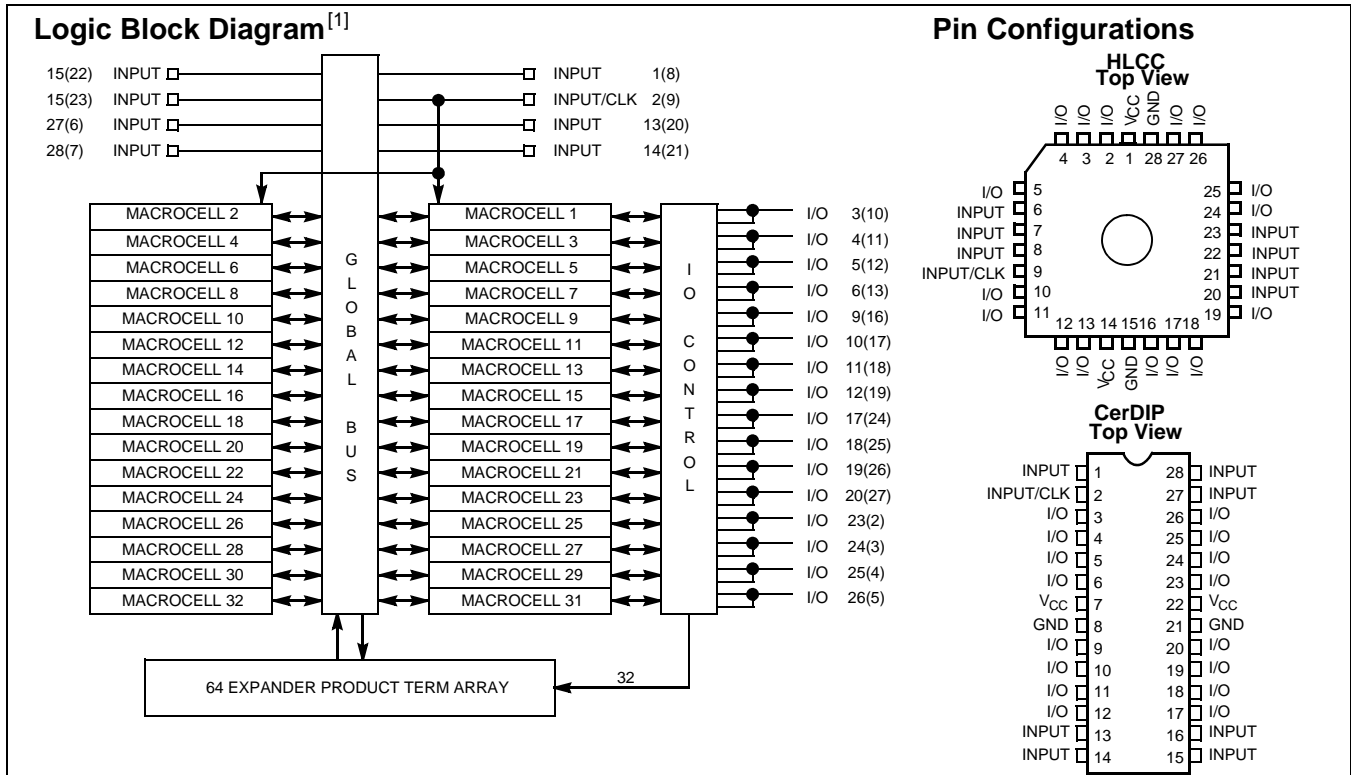



**USE ULTRA37000™ FOR
ALL NEW DESIGNS**

CY7C344B

Selection Guide

		7C344-15	7C344-20	7C344-25	Unit
Maximum Access Time		15	20	25	ns
Maximum Operating Current	Commercial	200	200	200	mA
	Military		220	220	
	Industrial	220	220	220	
Maximum Standby Current	Commercial	150	150	150	mA
	Military		170	170	
	Industrial	170	170	170	

Note:

1. Numbers in () refer to J-leaded packages.



Maximum Ratings

(Above which the useful life may be impaired. For user guidelines, not tested.)

- Storage Temperature-65°C to +150°C
- Ambient Temperature with Power Applied.....0°C to +70°C
- Maximum Junction Temperature (Under Bias)..... 150°C
- Supply Voltage to Ground Potential -2.0V to +7.0V
- Maximum Power Dissipation..... 1500 mW
- DC V_{CC} or GND Current.....500 mA

- Static Discharge Voltage (per MIL-STD-883, Method 3015) >2001V
- DC Output Current, per Pin-25 mA to +25 mA
- DC Input Voltage^[2]-3.0V to +7.0V
- DC Program Voltage..... +13.0V

Operating Range

Range	Ambient Temperature	V _{CC}
Commercial	0°C to +70°C	5V ±5%
Industrial	-40°C to +85°C	5V ±10%
Military	-55°C to +125°C (Case)	5V ±10%

Electrical Characteristics Over the Operating Range^[3]

Parameter	Description	Test Conditions	Min.	Max.	Unit	
V _{OH}	Output HIGH Voltage	V _{CC} = Min., I _{OH} = -4.0 mA	2.4		V	
V _{OL}	Output LOW Voltage	V _{CC} = Min., I _{OL} = 8 mA		0.45	V	
V _{IH}	Input HIGH Level		2.2	V _{CC} +0.3	V	
V _{IL}	Input LOW Level		-0.3	0.8	V	
I _{IX}	Input Current	GND ≤ V _{IN} ≤ V _{CC}	-10	+10	μA	
I _{OZ}	Output Leakage Current	V _O = V _{CC} or GND	-40	+40	μA	
I _{OS}	Output Short Circuit Current	V _{CC} = Max., V _{OUT} = 0.5V ^[4, 5]	-30	-90	mA	
I _{CC1}	Power Supply Current (Standby)	V _I = V _{CC} or GND (No Load)	Commercial		150	mA
			Military/Industrial		170	mA
I _{CC2}	Power Supply Current	V _I = V _{CC} or GND (No Load) f = 1.0 MHz ^[4, 6]	Commercial		200	mA
			Military/Industrial		220	mA
t _R	Recommended Input Rise Time			100	ns	
t _F	Recommended Input Fall Time			100	ns	

Capacitance

Parameter	Description	Test Conditions	Max.	Unit
C _{IN}	Input Capacitance	V _{IN} = 2V, f = 1.0 MHz	10	pF
C _{OUT}	Output Capacitance	V _{OUT} = 2.0V, f = 1.0 MHz	10	pF

AC Test Loads and Waveforms^[7]

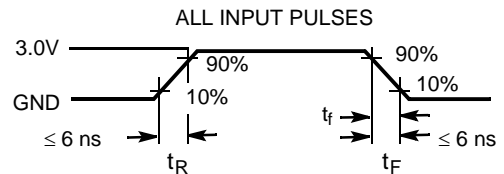
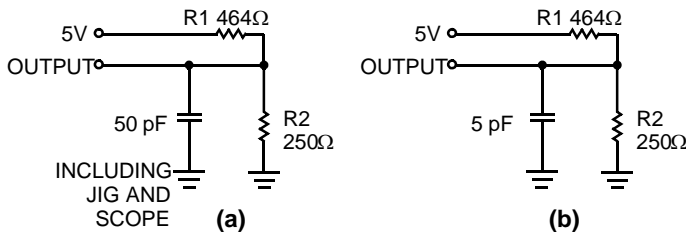

Equivalent to: THÉVENIN EQUIVALENT (commercial/military)
 163Ω
 OUTPUT ———— 1.75V

Notes:

2. Minimum DC input is -0.3V. During transitions, the inputs may undershoot to -2.0V for periods less than 20 ns.
3. Typical values are for T_A = 25°C and V_{CC} = 5V.
4. Guaranteed by design but not 100% tested.
5. Not more than one output should be tested at a time. Duration of the short circuit should not be more than one second. V_{OUT} = 0.5V has been chosen to avoid test problems caused by tester ground degradation.
6. Measured with device programmed as a 16-bit counter.
7. Part (a) in AC Test Load and Waveforms is used for all parameters except t_{ER} and t_{XZ}, which is used for part (b) in AC Test Load and Waveforms. All external timing parameters are measured referenced to external pins of the device.

Timing Delays

Timing delays within the CY7C344 may be easily determined using *Warp*®, *Warp Professional*™, or *Warp Enterprise*™ software. The CY7C344 has fixed internal delays, allowing the user to determine the worst case timing delays for any design.

Design Recommendations

Operation of the devices described herein with conditions above those listed under "Maximum Ratings" may cause permanent damage to the device. This is a stress rating only and functional operation of the device at these or any other conditions above those indicated in the operational sections of this data sheet is not implied. Exposure to absolute maximum ratings conditions for extended periods of time may affect device reliability. The CY7C344 contains circuitry to protect device pins from high-static voltages or electric fields; however, normal precautions should be taken to avoid applying any voltage higher than maximum rated voltages.

For proper operation, input and output pins must be constrained to the range $GND \leq (V_{IN} \text{ or } V_{OUT}) \leq V_{CC}$. Unused inputs must always be tied to an appropriate logic level (either V_{CC} or GND). Each set of V_{CC} and GND pins must be connected together directly at the device. Power supply decoupling capacitors of at least 0.2 μF must be connected between V_{CC} and GND. For the most effective decoupling, each V_{CC} pin should be separately decoupled.

Timing Considerations

Unless otherwise stated, propagation delays do not include expanders. When using expanders, add the maximum expander delay t_{EXP} to the overall delay.

When calculating synchronous frequencies, use t_{S1} if all inputs are on the input pins. t_{S2} should be used if data is applied at an I/O pin. If t_{S2} is greater than t_{CO1} , $1/t_{S2}$ becomes the limiting frequency in the data-path mode unless $1/(t_{WH} + t_{WL})$ is less than $1/t_{S2}$.

When expander logic is used in the data path, add the appropriate maximum expander delay, t_{EXP} to t_{S1} . Determine which of $1/(t_{WH} + t_{WL})$, $1/t_{CO1}$, or $1/(t_{EXP} + t_{S1})$ is the lowest frequency. The lowest of these frequencies is the maximum data-path frequency for the synchronous configuration.

When calculating external asynchronous frequencies, use t_{AS1} if all inputs are on dedicated input pins. If any data is applied to an I/O pin, t_{AS2} must be used as the required set-up time. If $(t_{AS2} + t_{AH})$ is greater than t_{ACO1} , $1/(t_{AS2} + t_{AH})$ becomes the limiting frequency in the data-path mode unless $1/(t_{AWH} + t_{AWL})$ is less than $1/(t_{AS2} + t_{AH})$.

When expander logic is used in the data path, add the appropriate maximum expander delay, t_{EXP} to t_{AS1} . Determine which of $1/(t_{AWH} + t_{AWL})$, $1/t_{ACO1}$, or $1/(t_{EXP} + t_{AS1})$ is the lowest frequency. The lowest of these frequencies is the maximum data-path frequency for the asynchronous configuration.

The parameter t_{OH} indicates the system compatibility of this device when driving other synchronous logic with positive input hold times, which is controlled by the same synchronous clock. If t_{OH} is greater than the minimum required input hold time of the subsequent synchronous logic, then the devices are guaranteed to function properly with a common synchronous clock under worst-case environmental and supply voltage conditions.

The parameter t_{AOH} indicates the system compatibility of this device when driving subsequent registered logic with a positive hold time and using the same clock as the CY7C344. In general, if t_{AOH} is greater than the minimum required input hold time of the subsequent logic (synchronous or asynchronous), then the devices are guaranteed to function properly under worst-case environmental and supply voltage conditions, provided the clock signal source is the same. This also applies if expander logic is used in the clock signal path of the driving device, but not for the driven device. This is due to the expander logic in the second device's clock signal path adding an additional delay (t_{EXP}), causing the output data from the preceding device to change prior to the arrival of the clock signal at the following device's register.

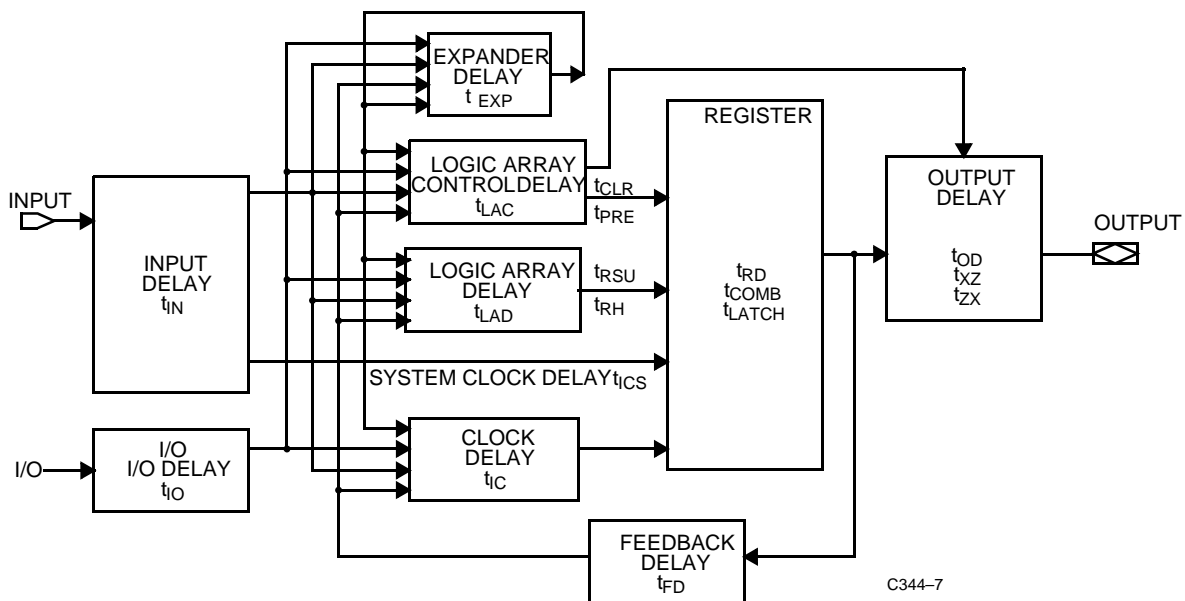

Figure 1. CY7C344 Timing Model



External Synchronous Switching Characteristics Over Operating Range ^[7]

Parameter	Description		7C344-15		7C344-20		7C344-25		Unit
			Min.	Max.	Min.	Max.	Min.	Max.	
t _{PD1}	Dedicated Input to Combinatorial Output Delay ^[8]	Com'I/Ind		15		20		25	ns
		Mil		15		20		25	
t _{PD2}	I/O Input to Combinatorial Output Delay ^[9]	Com'I/Ind		15		20		25	ns
		Mil		15		20		25	
t _{PD3}	Dedicated Input to Combinatorial Output Delay with Expander Delay ^[10]	Com'I/Ind		30		30		40	ns
		Mil		30		30		40	
t _{PD4}	I/O Input to Combinatorial Output Delay with Expander Delay ^[4, 11]	Com'I/Ind		30		30		40	ns
		Mil		30		30		40	
t _{EA}	Input to Output Enable Delay ^[4]	Com'I/Ind		20		20		25	ns
		Mil		20		20		25	
t _{ER}	Input to Output Disable Delay ^[4]	Com'I/Ind		20		20		25	ns
		Mil		20		20		25	
t _{CO1}	Synchronous Clock Input to Output Delay	Com'I/Ind		10		12		15	ns
		Mil		10		12		15	
t _{CO2}	Synchronous Clock to Local Feedback to Combinatorial Output ^[4, 12]	Com'I/Ind		20		22		29	ns
		Mil		20		22		29	
t _S	Dedicated Input or Feedback Set-Up Time to Synchronous Clock Input	Com'I/Ind	10		12		15		ns
		Mil	10		12		15		
t _H	Input Hold Time from Synchronous Clock Input ^[7]	Com'I/Ind	0		0		0		ns
		Mil	0		0		0		
t _{WH}	Synchronous Clock Input HIGH Time ^[4]	Com'I/Ind	6		7		8		ns
		Mil	6		7		8		
t _{WL}	Synchronous Clock Input LOW Time ^[4]	Com'I/Ind	6		7		8		ns
		Mil	6		7		8		
t _{RW}	Asynchronous Clear Width ^[4]	Com'I/Ind	20		20		25		ns
		Mil	20		20		25		
t _{RR}	Asynchronous Clear Recovery Time ^[4]	Com'I/Ind	20		20		25		ns
		Mil	20		20		25		
t _{RO}	Asynchronous Clear to Registered Output Delay ^[4]	Com'I/Ind		15		20		25	ns
		Mil		15		20		25	
t _{PW}	Asynchronous Preset Width ^[4]	Com'I /Ind	20		20		25		ns
		Mil	20		20		25		
t _{PR}	Asynchronous Preset Recovery Time ^[4]	Com'I /Ind	20		20		25		ns
		Mil	20		20		25		

Notes:

8. This parameter is the delay from an input signal applied to a dedicated input pin to a combinatorial output on any output pin. This delay assumes no expander terms are used to form the logic function.
9. This parameter is the delay associated with an input signal applied to an I/O macrocell pin to any output. This delay assumes no expander terms are used to form the logic function.
10. This parameter is the delay associated with an input signal applied to a dedicated input pin to combinatorial output on any output pin. This delay assumes expander terms are used to form the logic function and includes the worst-case expander logic delay for one pass through the expander logic. This parameter is tested periodically by sampling production material.
11. This parameter is the delay associated with an input signal applied to an I/O macrocell pin to any output pin. This delay assumes expander terms are used to form the logic function and includes the worst-case expander logic delay for one pass through the expander logic. This parameter is tested periodically by sampling production material.
12. This specification is a measure of the delay from synchronous register clock input to internal feedback of the register output signal to a combinatorial output for which the registered output signal is used as an input. This parameter assumes no expanders are used in the logic of the combinatorial output and the register is synchronously clocked. This parameter is tested periodically by sampling production material.



External Synchronous Switching Characteristics Over Operating Range (continued)^[7]

Parameter	Description		7C344-15		7C344-20		7C344-25		Unit
			Min.	Max.	Min.	Max.	Min.	Max.	
t _{PO}	Asynchronous Preset to Registered Output Delay ^[4]	Com'I/Ind		15		20		25	ns
		Mil		15		20		25	
t _{CF}	Synchronous Clock to Local Feedback Input ^[4, 13]	Com'I/Ind		4		4		7	ns
		Mil		4		4		7	
t _P	External Synchronous Clock Period (1/f _{MAX3}) ^[4]	Com'I/Ind	13		14		16		ns
		Mil	13		14		16		
f _{MAX1}	External Maximum Frequency(1/(t _{CO1} + t _S)) ^[4, 14]	Com'I/Ind	50.0		41.6		33.3		MHz
		Mil	50.0		41.6		33.3		
f _{MAX2}	Maximum Frequency with Internal Only Feedback (1/(t _{CF} + t _S)) ^[4, 15]	Com'I/Ind	71.4		62.5		45.4		MHz
		Mil	71.4		62.5		45.4		
f _{MAX3}	Data Path Maximum Frequency, least of 1/(t _{WL} + t _{WH}), 1/(t _S + t _H), or (1/t _{CO1}) ^[4, 16]	Com'I/Ind	83.3		71.4		62.5		MHz
		Mil	83.3		71.4		62.5		
f _{MAX4}	Maximum Register Toggle Frequency 1/(t _{WL} + t _{WH}) ^[4, 17]	Com'I/Ind	83.3		71.4		62.5		MHz
		Mil	83.3		71.4		62.5		
t _{OH}	Output Data Stable Time from Synchronous Clock Input ^[4, 18]	Com'I/Ind	3		3		3		ns
		Mil	3		3		3		

Notes:

- 13. This specification is a measure of the delay associated with the internal register feedback path. This delay plus the register set-up time, t_S, is the minimum internal period for an internal state machine configuration. This parameter is tested periodically by sampling production material.
- 14. This specification indicates the guaranteed maximum frequency at which a state machine configuration with external only feedback can operate.
- 15. This specification indicates the guaranteed maximum frequency at which a state machine with internal-only feedback can operate. If register output states must also control external points, this frequency can still be observed as long as it is less than 1/t_{CO1}. This specification assumes no expander logic is used. This parameter is tested periodically by sampling production material.
- 16. This frequency indicates the maximum frequency at which the device may operate in data-path mode (dedicated input pin to output pin). This assumes that no expander logic is used.
- 17. This specification indicates the guaranteed maximum frequency in synchronous mode, at which an individual output or buried register can be cycled by a clock signal applied to either a dedicated input pin or an I/O pin.
- 18. This parameter indicates the minimum time after a synchronous register clock input that the previous register output data is maintained on the output pin.



External Asynchronous Switching Characteristics Over Operating Range^[7]

Parameter	Description		7C344-15		7C344-20		7C344-25		Unit
			Min.	Max.	Min.	Max.	Min.	Max.	
t _{ACO1}	Asynchronous Clock Input to Output Delay	Com'l/Ind		15		20		25	ns
		Mil		15		20		25	
t _{ACO2}	Asynchronous Clock Input to Local Feedback to Combinatorial Output ^[19]	Com'l/Ind		30		30		37	ns
		Mil		30		30		37	
t _{AS}	Dedicated Input or Feedback Set-Up Time to Asynchronous Clock Input	Com'l/Ind	7		9		12		ns
		Mil	7		9		12		
t _{AH}	Input Hold Time from Asynchronous Clock Input	Com'l/Ind	7		9		12		ns
		Mil	7		9		12		
t _{AWH}	Asynchronous Clock Input HIGH Time ^[4, 20]	Com'l/Ind	6		7		9		ns
		Mil	6		7		9		
t _{AWL}	Asynchronous Clock Input LOW Time ^[4]	Com'l/Ind	7		9		11		ns
		Mil	7		9		11		
t _{ACF}	Asynchronous Clock to Local Feedback Input ^[4, 21]	Com'l/Ind		18		18		21	ns
		Mil		18		18		21	
t _{AP}	External Asynchronous Clock Period (1/f _{MAX4}) ^[4]	Com'l/Ind	13		16		20		ns
		Mil	13		16		20		
f _{MAXA1}	External Maximum Frequency in Asynchronous Mode 1/(t _{ACO1} + t _{AS}) ^[4, 22]	Com'l/Ind	45.4		34.4		27		MHz
		Mil	45.4		34.4		27		
f _{MAXA2}	Maximum Internal Asynchronous Frequency 1/(t _{ACF} + t _{AS}) or 1/(t _{AWH} + t _{AWL}) ^[4, 23]	Com'l/Ind	40		37		30.3		MHz
		Mil	40		37		30.3		
f _{MAXA3}	Data Path Maximum Frequency in Asynchronous Mode ^[4, 24]	Com'l/Ind	66.6		50		40		MHz
		Mil	66.6		50		40		
f _{MAXA4}	Maximum Asynchronous Register Toggle Frequency 1/(t _{AWH} + t _{AWL}) ^[4, 25]	Com'l/Ind	76.9		62.5		50		MHz
		Mil	76.9		62.5		50		
t _{AOH}	Output Data Stable Time from Asynchronous Clock Input ^[4, 26]	Com'l/Ind	15		15		15		ns
		Mil	15		15		15		

Notes:

19. This specification is a measure of the delay from an asynchronous register clock input to internal feedback of the registered output signal to a combinatorial output for which the registered output signal is used as an input. Assumes no expanders are used in logic of combinatorial output or the asynchronous clock input. This parameter is tested periodically by sampling production material.
20. This parameter is measured with a positive-edge-triggered clock at the register. For negative edge triggering, the t_{AWH} and t_{AWL} parameters must be swapped. If a given input is used to clock multiple registers with both positive and negative polarity, t_{AWH} should be used for both t_{AWH} and t_{AWL}.
21. This specification is a measure of the delay associated with the internal register feedback path for an asynchronously clocked register. This delay plus the asynchronous register set-up time, t_{AS}, is the minimum internal period for an asynchronously clocked state machine configuration. This delay assumes no expander logic in the asynchronous clock path. This parameter is tested periodically by sampling production material.
22. This parameter indicates the guaranteed maximum frequency at which an asynchronously clocked state machine configuration with external feedback can operate. It is assumed that no expander logic is employed in the clock signal path or data path.
23. This specification indicates the guaranteed maximum frequency at which an asynchronously clocked state machine with internal-only feedback can operate. If register output states must also control external points, this frequency can still be observed as long as this frequency is less than 1/t_{ACO1}. This specification assumes no expander logic is utilized. This parameter is tested periodically by sampling production material.
24. This specification indicates the guaranteed maximum frequency at which an individual output or buried register can be cycled in asynchronously clocked mode. This frequency is least of 1/(t_{AWH} + t_{AWL}), 1/(t_{AS} + t_{AH}), or 1/t_{ACO1}. It also indicates the maximum frequency at which the device may operate in the asynchronously clocked data-path mode. Assumes no expander logic is used.
25. This specification indicates the guaranteed maximum frequency at which an individual output or buried register can be cycled in asynchronously clocked mode by a clock signal applied to an external dedicated input or an I/O pin.
26. This parameter indicates the minimum time that the previous register output data is maintained on the output pin after an asynchronous register clock input to an external dedicated input or I/O pin.



Typical Internal Switching Characteristics Over Operating Range^[7]

Parameter	Description		7C344-15		7C344-20		7C344-25		Unit
			Min.	Max.	Min.	Max.	Min.	Max.	
t _{IN}	Dedicated Input Pad and Buffer Delay	Com'I/Ind		4		5		7	ns
		Mil		4		5		7	
t _{IO}	I/O Input Pad and Buffer Delay	Com'I/Ind		4		5		7	ns
		Mil		4		5		7	
t _{EXP}	Expander Array Delay	Com'I/Ind		8		10		15	ns
		Mil		8		10		15	
t _{LAD}	Logic Array Data Delay	Com'I/Ind		7		9		10	ns
		Mil		7		9		10	
t _{LAC}	Logic Array Control Delay	Com'I/Ind		5		7		7	ns
		Mil		5		7		7	
t _{OD}	Output Buffer and Pad Delay	Com'I/Ind		4		5		5	ns
		Mil		4		5		5	
t _{ZX}	Output Buffer Enable Delay ^[27]	Com'I/Ind		7		8		11	ns
		Mil		7		8		11	
t _{XZ}	Output Buffer Disable Delay	Com'I/Ind		7		8		11	ns
		Mil		7		8		11	
t _{RSU}	Register Set-Up Time Relative to Clock Signal at Register	Com'I/Ind	5		5		8		ns
		Mil	5		5		8		
t _{RH}	Register Hold Time Relative to Clock Signal at Register	Com'I/Ind	7		9		12		ns
		Mil	7		9		12		
t _{LATCH}	Flow-Through Latch Delay	Com'I/Ind		1		1		3	ns
		Mil		1		1		3	
t _{RD}	Register Delay	Com'I/Ind		1		1		1	ns
		Mil		1		1		1	
t _{COMB}	Transparent Mode Delay ^[28]	Com'I/Ind		1		1		3	ns
		Mil		1		1		3	
t _{CH}	Clock HIGH Time	Com'I/Ind	6		7		8		ns
		Mil	6		7		8		
t _{CL}	Clock LOW Time	Com'I/Ind	6		7		8		ns
		Mil	6		7		8		
t _{IC}	Asynchronous Clock Logic Delay	Com'I/Ind		7		8		10	ns
		Mil		7		8		10	
t _{ICS}	Synchronous Clock Delay	Com'I/Ind		1		2		3	ns
		Mil		1		2		3	
t _{FD}	Feedback Delay	Com'I/Ind		1		1		1	ns
		Mil		1		1		1	
t _{PRE}	Asynchronous Register Preset Time	Com'I/Ind		5		6		9	ns
		Mil		5		6		9	

Notes:

27. Sample tested only for an output change of 500 mV.

28. This specification guarantees the maximum combinatorial delay associated with the macrocell register bypass when the macrocell is configured for combinatorial operation.



Typical Internal Switching Characteristics Over Operating Range^[7] (continued)

Parameter	Description		7C344-15		7C344-20		7C344-25		Unit
			Min.	Max.	Min.	Max.	Min.	Max.	
t _{CLR}	Asynchronous Register Clear Time	Com'l/Ind		5		6		9	ns
		Mil		5		6		9	
t _{PCW}	Asynchronous Preset and Clear Pulse Width	Com'l/Ind	5		5		7		ns
		Mil	5		5		7		
t _{PCR}	Asynchronous Preset and Clear Recovery Time	Com'l/Ind	5		5		7		ns
		Mil	5		5		7		

Switching Waveforms

External Combinatorial

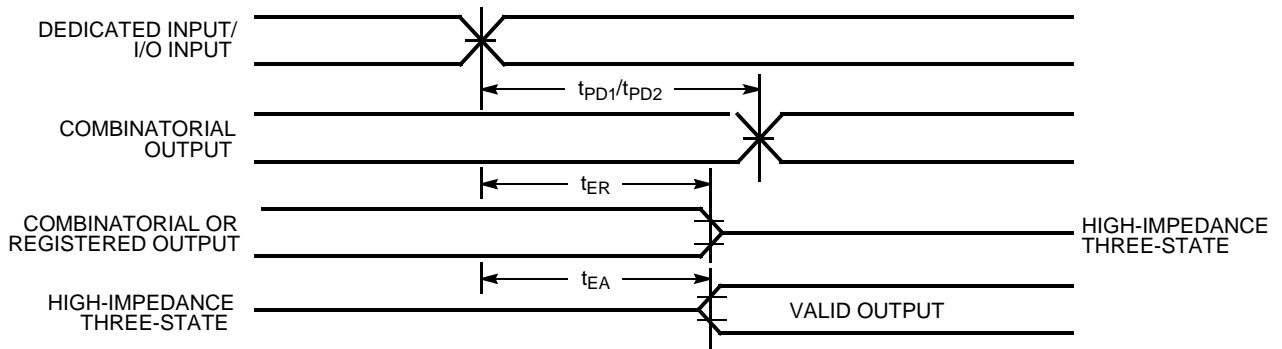

External Synchronous

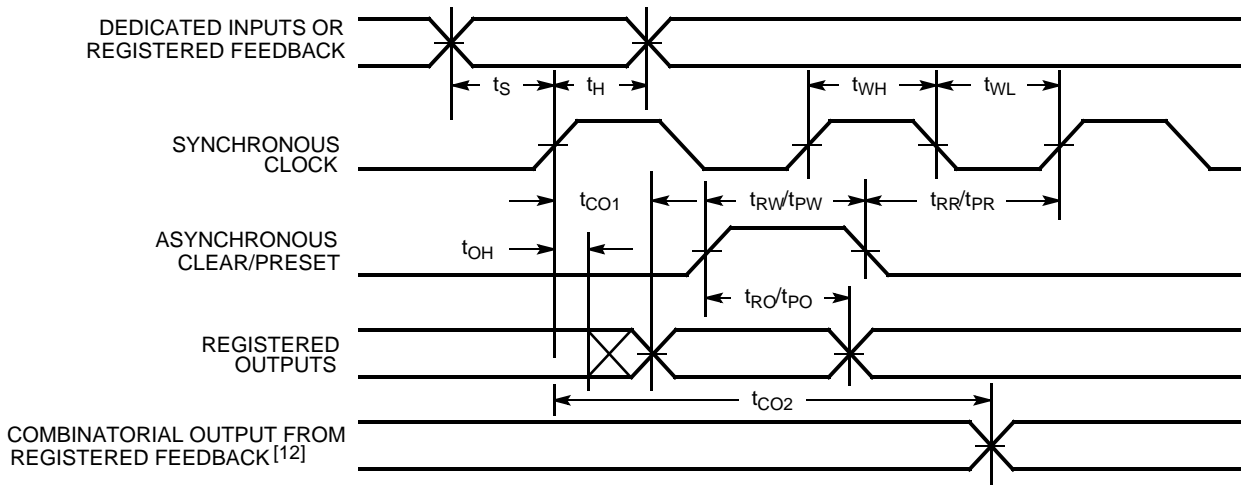

Switching Waveforms (continued)

External Asynchronous

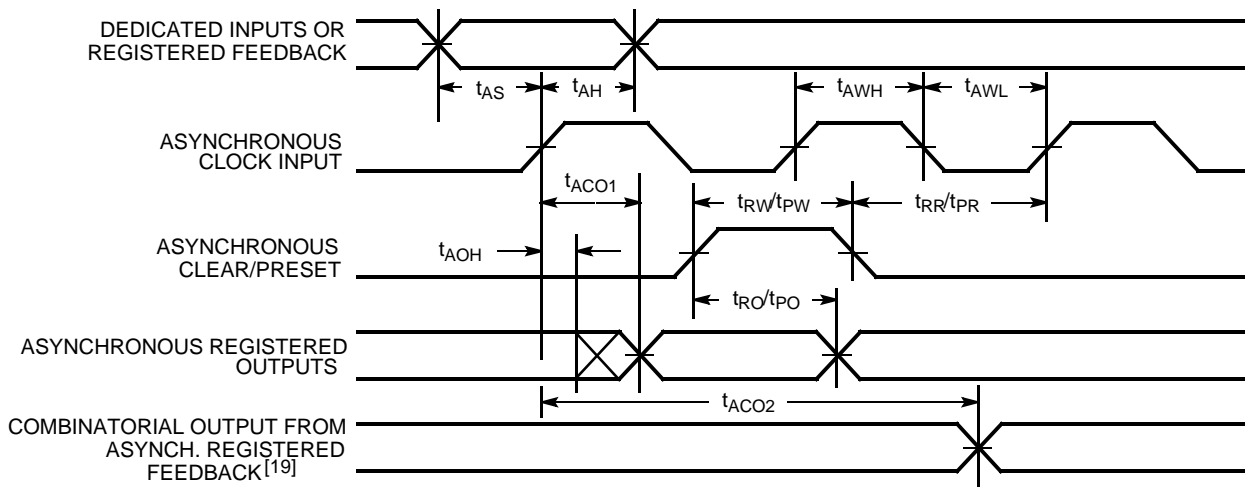

Internal Combinatorial

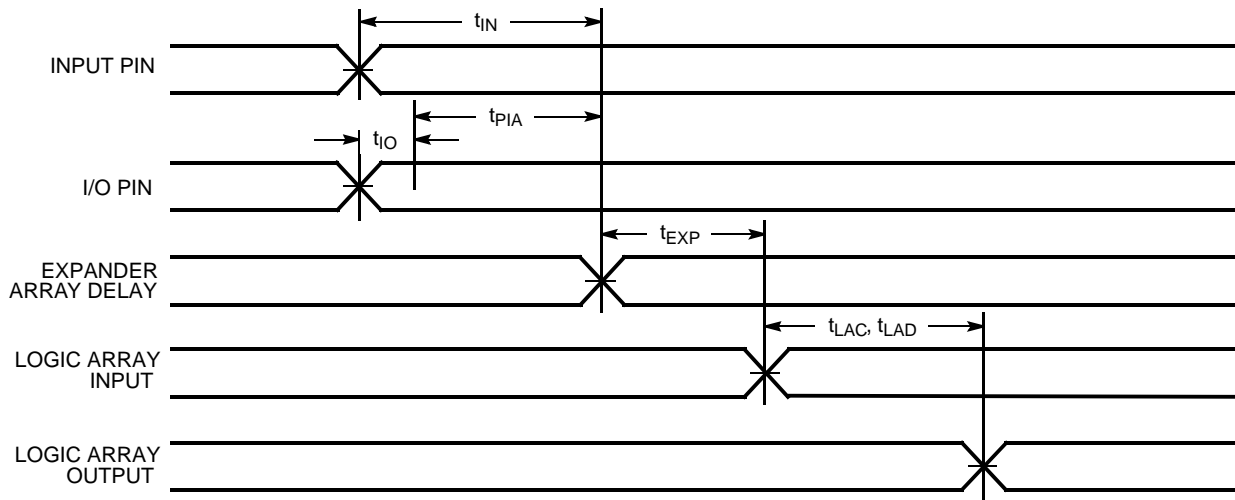

Switching Waveforms (continued)

Internal Asynchronous

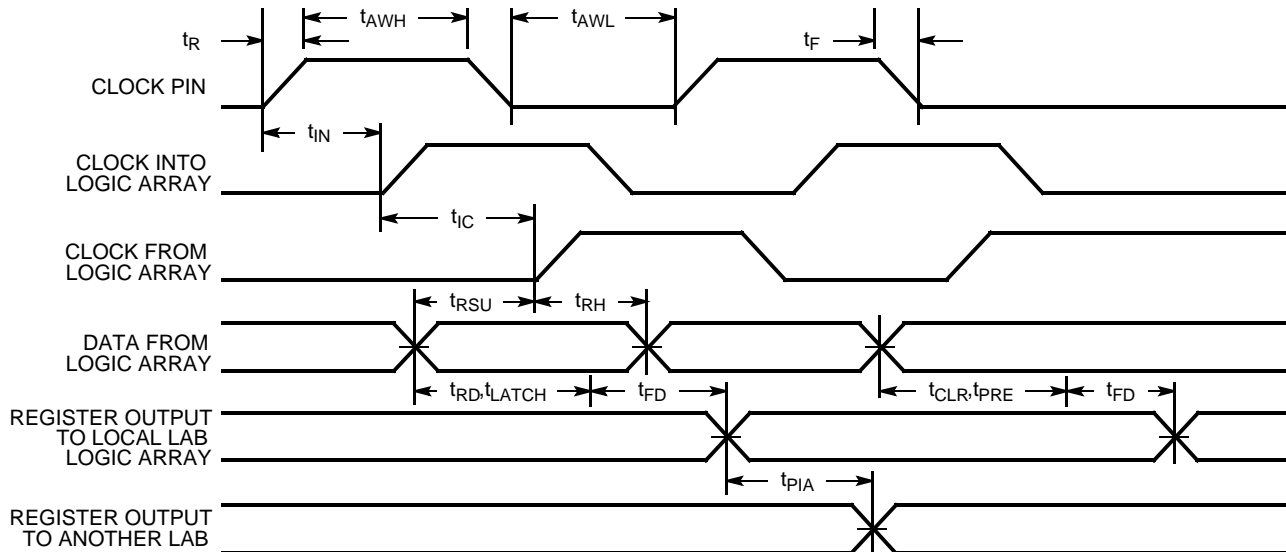

Internal Synchronous (Input Path)

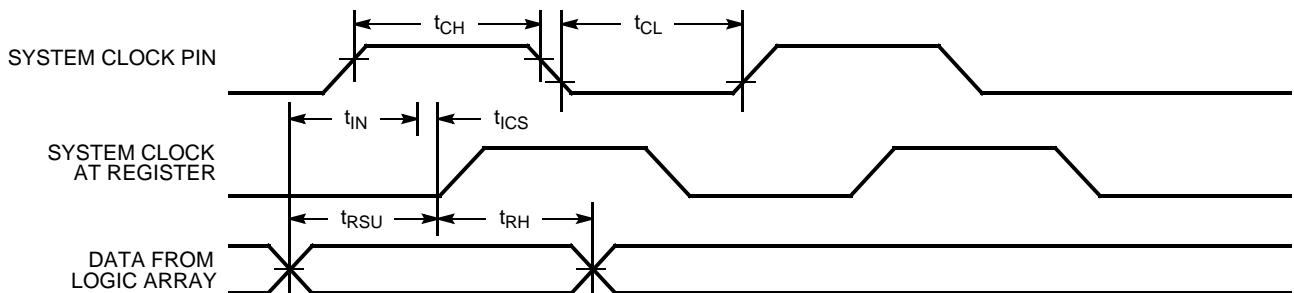

Internal Synchronous (Output Path)

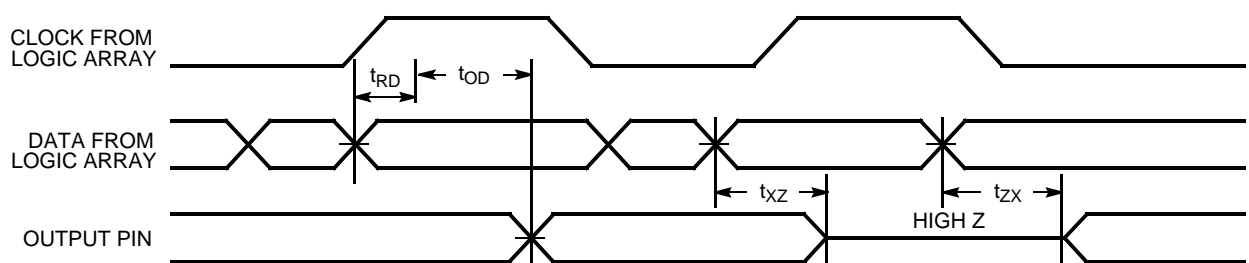



**USE ULTRA37000™ FOR
ALL NEW DESIGNS**

CY7C344B

Ordering Information

Speed (ns)	Ordering Code	Package Name	Package Type	Operating Range
15	CY7C344-15HC/HI	H64	28-Lead Windowed Leaded Chip Carrier	Commercial/Industrial
	CY7C344-15JC/JI	J64	28-Lead Plastic Leaded Chip Carrier	
	CY7C344-15PC/PI	P21	28-Lead (300-Mil) Molded DIP	
	CY7C344-15WC/WI	W22	28-Lead Windowed CerDIP	
20	CY7C344-20HC/HI	H64	28-Lead Windowed Leaded Chip Carrier	Commercial/Industrial
	CY7C344-20JC/JI	J64	28-Lead Plastic Leaded Chip Carrier	
	CY7C344-20PC/PI	P21	28-Lead (300-Mil) Molded DIP	
	CY7C344-20WC/WI	W22	28-Lead Windowed CerDIP	
	CY7C344-20HMB	H64	28-Lead Windowed Leaded Chip Carrier	Military
	CY7C344-20WMB	W22	28-Lead Windowed CerDIP	
25	CY7C344-25HC/HI	H64	28-Lead Windowed Leaded Chip Carrier	Commercial/Industrial
	CY7C344-25JC/JI	J64	28-Lead Plastic Leaded Chip Carrier	
	CY7C344-25PC/PI	P21	28-Lead (300-Mil) Molded DIP	
	CY7C344-25WC/WI	W22	28-Lead Windowed CerDIP	
	CY7C344-25HMB	H64	28-Lead Windowed Leaded Chip Carrier	Military
	CY7C344-25WMB	W22	28-Lead Windowed CerDIP	

**MILITARY SPECIFICATIONS
Group A Subgroup Testing**

DC Characteristics

Parameter	Subgroups
V _{OH}	1, 2, 3
V _{OL}	1, 2, 3
V _{IH}	1, 2, 3
V _{IL}	1, 2, 3
I _{Ix}	1, 2, 3
I _{OZ}	1, 2, 3
I _{CC1}	1, 2, 3

Switching Characteristics

Parameter	Subgroups
t _{PD1}	7, 8, 9, 10, 11
t _{PD2}	7, 8, 9, 10, 11
t _{PD3}	7, 8, 9, 10, 11
t _{CO1}	7, 8, 9, 10, 11
t _S	7, 8, 9, 10, 11
t _H	7, 8, 9, 10, 11
t _{ACO1}	7, 8, 9, 10, 11
t _{ACO1}	7, 8, 9, 10, 11
t _{AS}	7, 8, 9, 10, 11
t _{AH}	7, 8, 9, 10, 11

Package Diagrams

28-Pin Windowed Leaded Chip Carrier H64

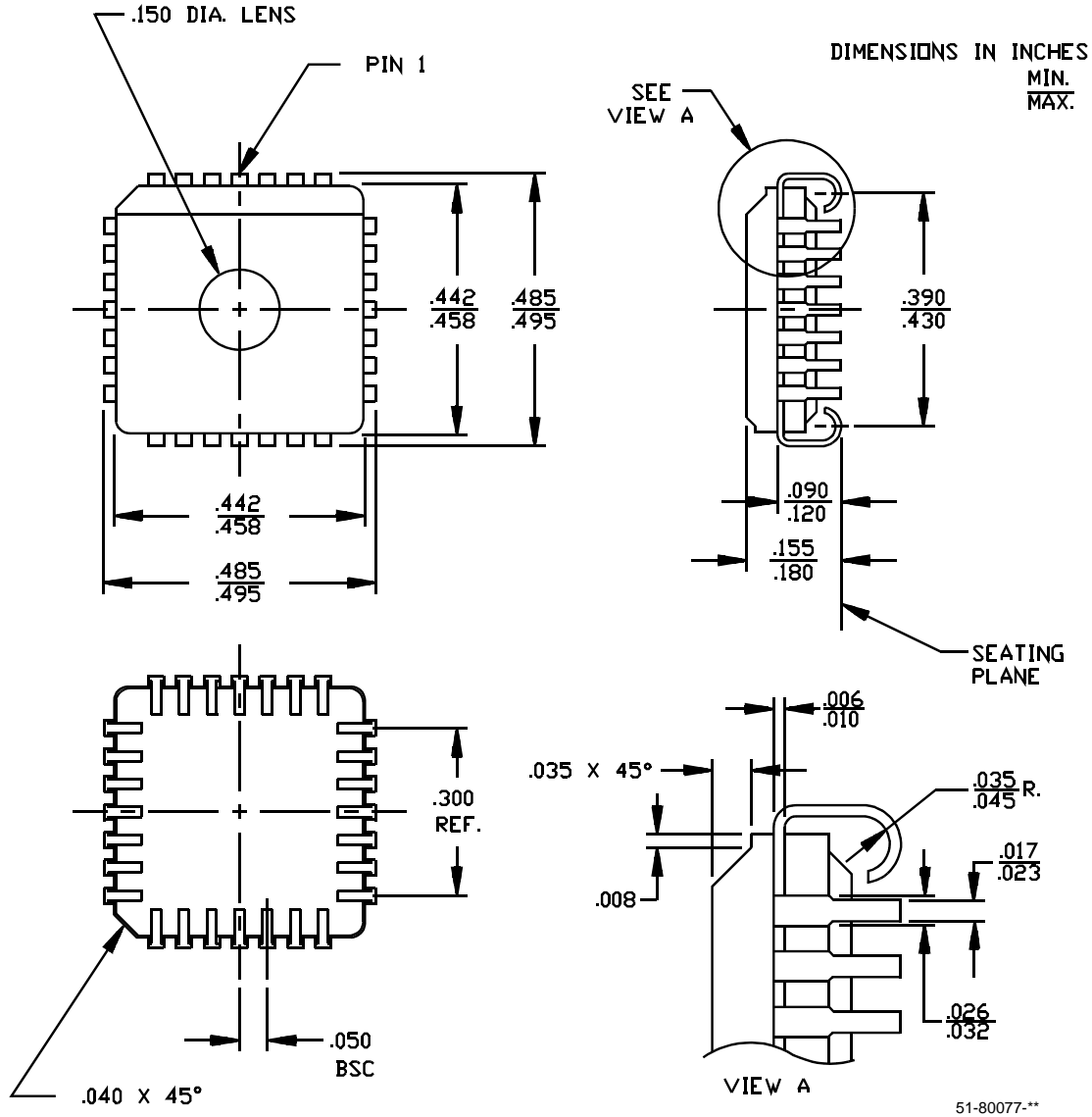

Package Diagrams (continued)

28-Lead Plastic Leaded Chip Carrier J64

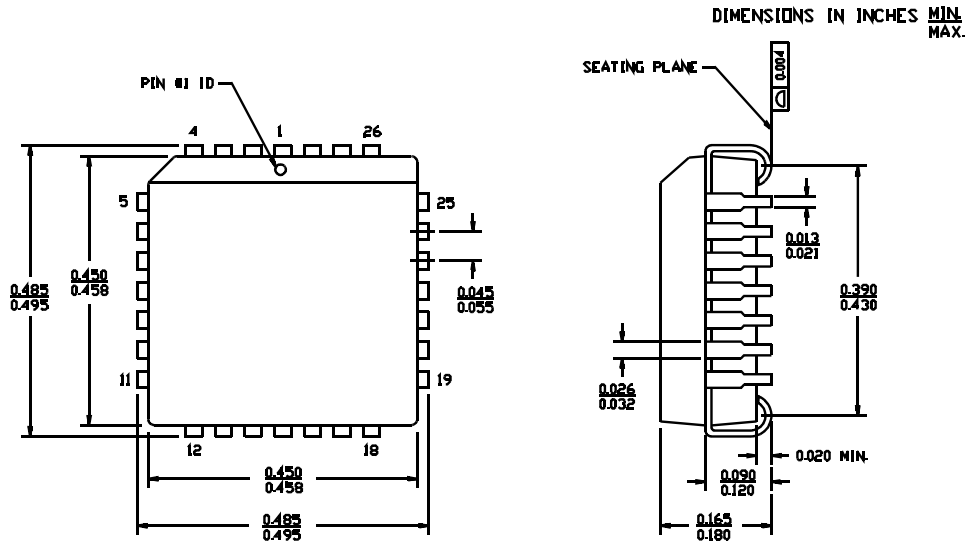

28-Lead (300-Mil) PDIP P21

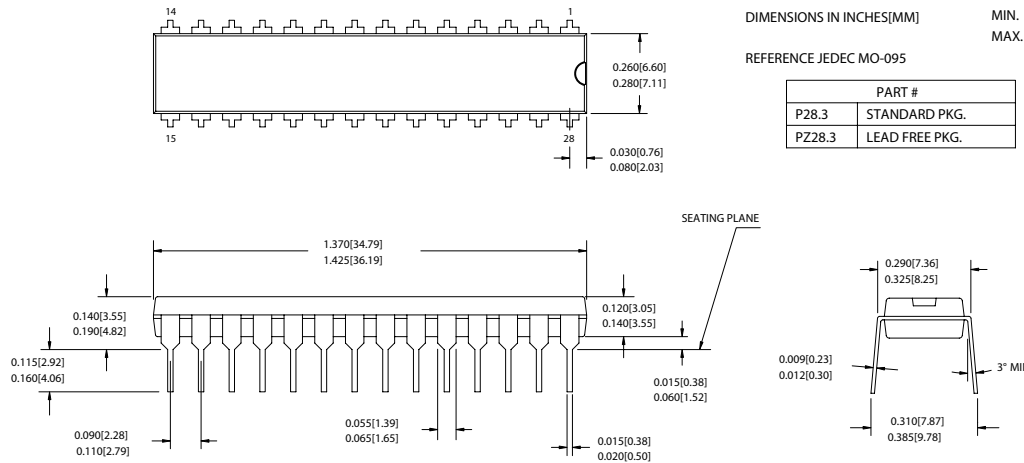

Package Diagrams (continued)

28-Lead (300-Mil) Windowed CerDIP W22
MIL-STD-1835 D-15 Config. A

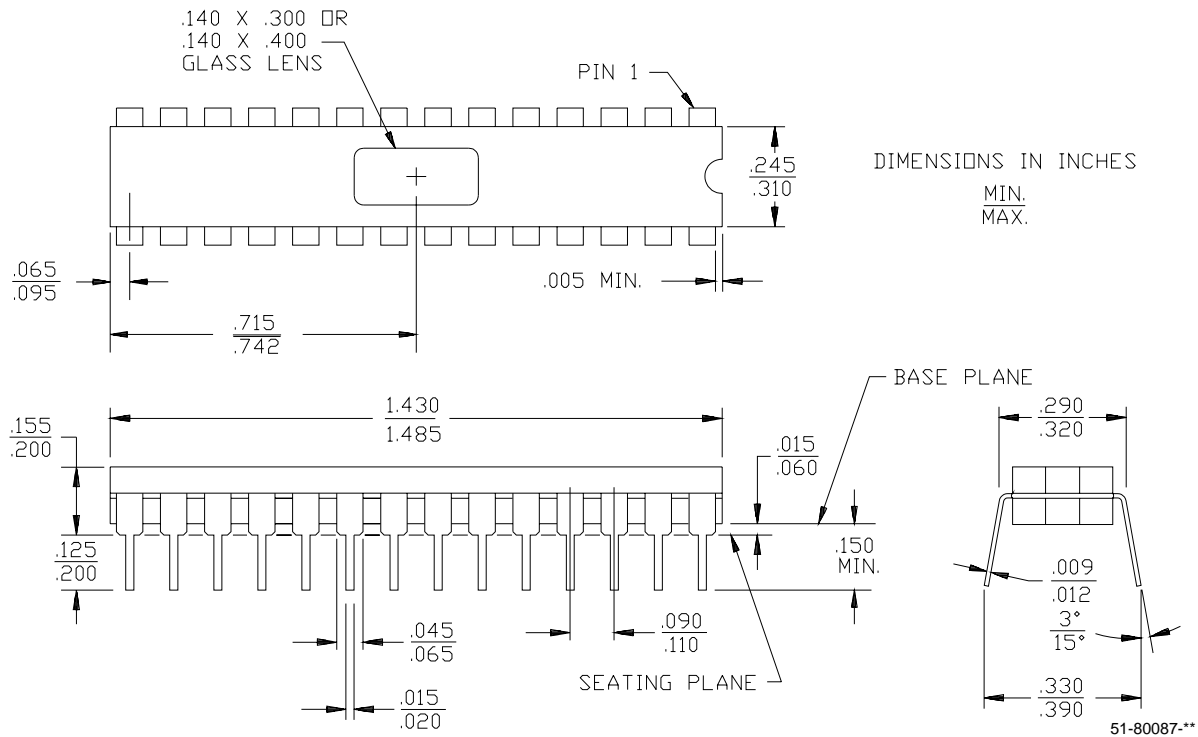

MAX and Warp are registered trademarks and Ultra37000, Warp Professional and Warp Enterprise are trademarks of Cypress Semiconductor Corporation. All products and company names mentioned in this document may be the trademarks of their respective holders.



**USE ULTRA37000™ FOR
ALL NEW DESIGNS**

CY7C344B

Document History Page

Document Title: CY7C344 32-Macrocell MAX® EPLD Document Number: 38-03006				
REV.	ECN NO.	Issue Date	Orig. of Change	Description of Change
**	106271	04/19/01	SZV	Change from Spec number: 38-00127 to 38-03006
*A	213375	See ECN	FSG	Added note to title page: "Use Ultra37000 For All New Designs"

This datasheet has been downloaded from:

www.DatasheetCatalog.com

Datasheets for electronic components.



LittleDiode supplies new, hard to find or obsolete electronic components and semiconductors all over the world.

With over two million different components listed you are sure to find the part you need.

Feel free to visit us today at our online store:

LittleDiode.com

Looking forward to providing you with the best possible service.