

Features

- Radiation Hardened
 - Total Dose $>10^5$ RAD (Si)
 - Transient Upset $<10^8$ RAD (Si)/s
 - Latch Up Free EPI-CMOS
- Low Power Consumption
 - IDDSB = 20 μ A
- Pin Compatible with NMOS 8255A and the Intersil 82C55A
- High Speed, No "Wait State" Operation with 5MHz HS-80C86RH
- 24 Programmable I/O Pins
- Bus-Hold Circuitry on All I/O Ports Eliminates Pull-Up Resistors
- Direct Bit Set/Reset Capability
- Enhanced Control Word Read Capability
- Hardened Field, Self-Aligned, Junction Isolated CMOS Process
- Single 5V Supply
- 2.0mA Drive Capability on All I/O Port Outputs
- Military Temperature Range: -55°C to +125°C

Description

The Intersil HS-82C55ARH is a high performance, radiation hardened CMOS version of the industry standard 8255A and is manufactured using a hardened field, self-aligned silicongate CMOS process. It is a general purpose programmable I/O device which may be used with many different microprocessors. There are 24 I/O pins which are organized into two 8-bit and two 4-bit ports. Each port may be programmed to function as either an input or an output. Additionally, one of the 8-bit ports may be programmed for bi-directional operation, and the two 4-bit ports can be programmed to provide handshaking capabilities. The high performance, radiation hardness, and industry standard configuration of the HS-82C55ARH make it compatible with the HS-80C86RH radiation hardened microprocessor.

Static CMOS circuit design insures low operating power. Bus hold circuitry eliminates the need for pull-up resistors. The Intersil hardened field CMOS process results in performance equal to or greater than existing radiation resistant products at a fraction of the power.

Ordering Information

PART NUMBER	TEMPERATURE	PACKAGE
HS1-82C55ARH-Q	-55°C to +125°C	40 Lead SBDIP
HS1-82C55ARH-8	-55°C to +125°C	40 Lead SBDIP
HS1-82C55ARH/Sample	+25°C	40 Lead SBDIP

Pinout

40 LEAD CERAMIC DUAL-IN-LINE
METAL SEAL PACKAGE (SBDIP)
MIL-STD-1835 CDIP2-T40
TOP VIEW

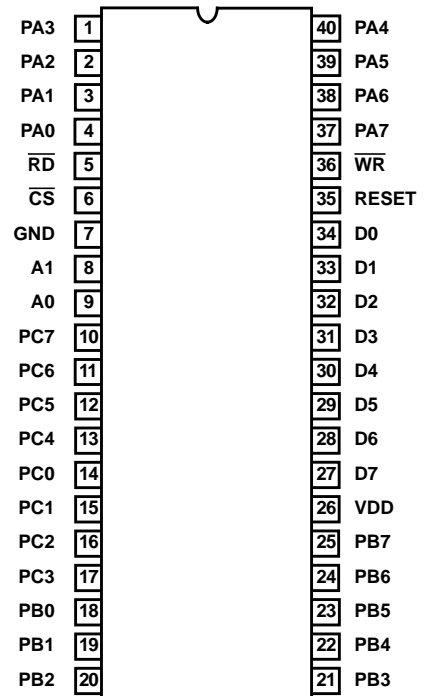

Pin Description

PIN	DESCRIPTION
D7 - D0	Data Bus (Bi-Directional)
RESET	Reset Input
\overline{CS}	Chip Select
\overline{RD}	Read Input
\overline{WR}	Write Input
A0 - A1	Port Address
PA7 - PA0	Port A (Bit)
PB& - PB0	Port B (Bit)
PC7 - PC0	Port C (Bit)
VDD	+5 volts
GND	0 volts

HS-82C55ARH

Pin Description

SYMBOL	PIN NUMBERS	TYPE	DESCRIPTION
PA0-7	1-4, 37-40	I/O	Port A: General purpose I/O Port. Data direction and mode is determined by the contents of the Control Word.
PB0-7	18-25	I/O	Port B: General purpose I/O port. See Port A.
PC0-3	14-17	I/O	Port C (Lower): Combination I/O port and control port associated with Port B. See Port A.
PC4-7	10-13	I/O	Port C (Upper): Combination I/O Port and control port associated with Port A. See Port A.
D0-7	27-34	I/O	Bidirectional Data Bus: Three-State data bus enabled as an input when \overline{CS} and \overline{WR} are low and as an output when \overline{CS} and \overline{RD} are low.
VDD	26	I	VDD: The +5V power supply pin. A 0.1 μ F capacitor between pins 26 and 7 is recommended for decoupling.
GND	7	I	Ground.
CS	6	I	Chip Select: A "low" on this input pin enables the communication between the HS-82C55ARH and the CPU.
RD	5	I	Read: A "low" on this input pin enables the HS-82C55ARH to send the data or status information to the CPU on the data bus. In essence, it allows the CPU to "read from" the HS-82C55ARH.
WR	36	I	Write: A "low" on this input pin enables the CPU to write data or control words into the HS-82C55ARH.
A0 and A1	8, 9	I	Port Select 0 and Port Select 1: These input signals, in conjunction with the \overline{RD} and \overline{WR} inputs, control the selection of one of the three ports or the control word registers. They are normally connected to the Least Significant Bits of the address bus (A0 and A1).
Reset	35	I	Reset: A "high" on this input clears the control register and all ports (A, B, C) are set to the input mode. "Bus hold" devices internal to the HS-82C55ARH will hold the I/O port inputs to a logic "1" state with a maximum hold current of 400 μ A.

Functional Diagram

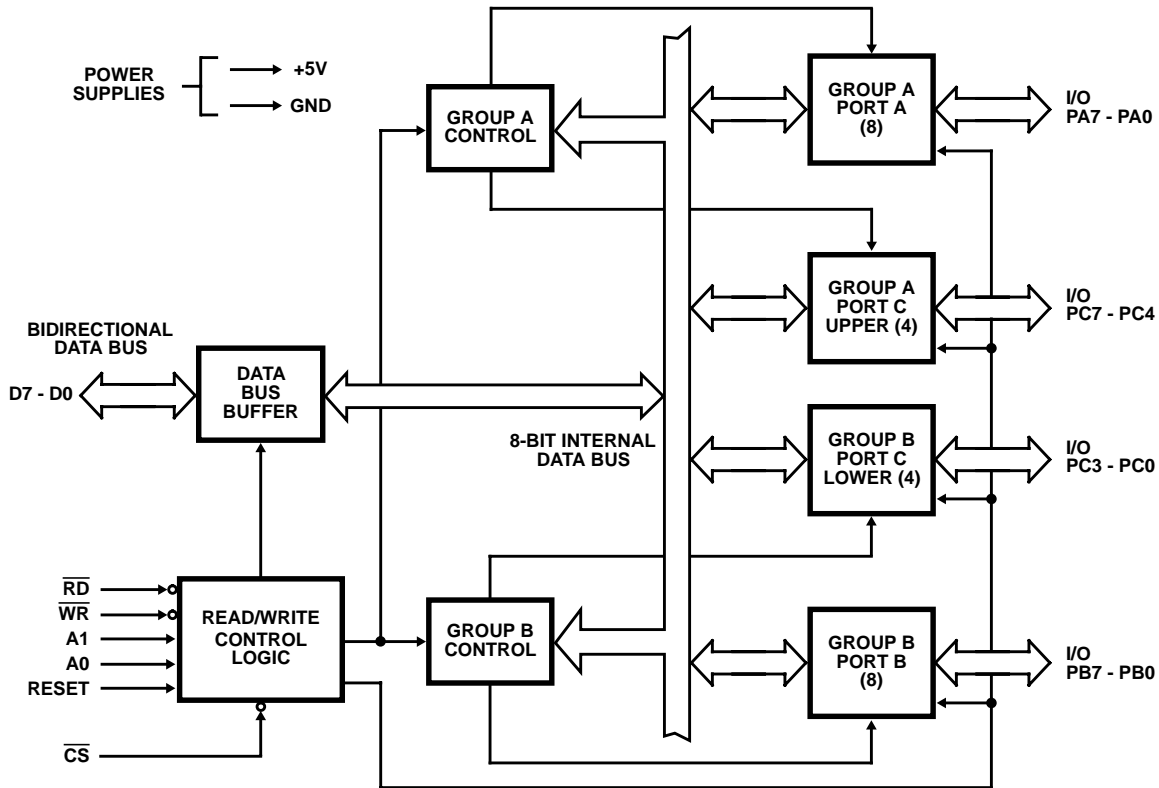

Specifications HS-82C55ARH

Absolute Maximum Ratings

Supply Voltage	+7.0V
Input, Output or I/O Voltage	VSS-0.3V to VDD+0.3V
Storage Temperature Range	-65°C to +150°C
Junction Temperature	+175°C
Lead Temperature (Soldering 10s)	+300°C
ESD Classification	Class 1

Reliability Information

Thermal Resistance	θ_{JA}	θ_{JC}
SBDIP Package	40°C/W	6°C/W
Maximum Package Power Dissipation at +125°C Ambient		
SBDIP Package	1.25W	
If device power exceeds package dissipation capability, provide heat sinking or derate linearly at the following rate:		
SBDIP Package	.25.0mW/C	

CAUTION: Stresses above those listed in "Absolute Maximum Ratings" may cause permanent damage to the device. This is a stress only rating and operation of the device at these or any other conditions above those indicated in the operational sections of this specification is not implied.

Operating Conditions

Operating Voltage Range	+4.5V to +5.5V	Input Low Voltage	.0V to +0.8V
Operating Temperature Range	-55°C to +125°C	Input High Voltage	VDD -1.5V to VDD

TABLE 1. DC ELECTRICAL PERFORMANCE CHARACTERISTICS

PARAMETER	SYMBOL	CONDITIONS	GROUP A SUBGROUP	TEMPERATURE	LIMITS		UNITS
					MIN	MAX	
TTL Output High Voltage	VOH1	VDD = 4.5V, IO = -2.5mA, VIN = 0V, 4.5V	1, 2, 3	-55°C, +25°C, +125°C	3.0	-	V
CMOS Output High Voltage	VOH2	VDD = 4.5V, IO = -100µA, VIN = 0V, 4.5V	1, 2, 3	-55°C, +25°C, +125°C	VDD-0.4	-	V
Output Low Voltage	VOL	VDD = 4.5V, IO = 2.5mA, VIN = 0V, 4.5V	1, 2, 3	-55°C, +25°C, +125°C	-	0.4	V
Input Leakage Current	IIL or IIH	VDD = 5.5V, VIN = 0V, 5.5V	1, 2, 3	-55°C, +25°C, +125°C	-1.0	1.0	µA
Output Leakage Current	IOZL or IOZH	VDD = 5.5V, VIN = 0V, 5.5V	1, 2, 3	-55°C, +25°C, +125°C	-10	10	µA
Input Current Bus Hold High	IBHH	VDD = 4.5V or 5.5V, VIN = 3.0V (See Note 1) Ports A, B, C	1, 2, 3	-55°C, +25°C, +125°C	-800	-60	µA
Input Current Bus Hold Low	IBHL	VDD = 4.5V or 5.5V, VIN = 1.0V (See Note 2) Port A	1, 2, 3	-55°C, +25°C, +125°C	60	800	µA
Standby Power Supply Current	IDDSB	VDD = 5.5V, IO = 0mA, VIN = GND or VDD	1, 2, 3	-55°C, +25°C, +125°C	-	20	µA
Darlington Drive Voltage	VDAR	VDD = 4.5V, IO = -2.0mA, VIN = GND or VDD	1, 2, 3	-55°C, +25°C, +125°C	3.9	-	V
Functional Tests	FT	VDD = 4.5V and 5.5V, VIN = GND or VDD, f = 1MHz	7, 8A, 8B	-55°C, +25°C, +125°C	-	-	-
Noise Immunity Functional Test (Note 4)	FN	VDD = 5.5V, VIN = GND or VDD - 1.5V and VDD = 4.5V, VIN = 0.8V or VDD	7, 8A, 8B	-55°C, +25°C, +125°C	-	-	-

NOTES:

1. IBHH should be measured after raising VIN and then lowering to 3.0V.
2. IBHL should be measured after lowering VIN to VSS and then raising to 0.8V.
3. No internal current limiting exists on the Port Outputs. A resistor must be added externally to limit the current.
4. For VIH (VDD = 5.5V) and VIL (VDD = 4.5V) each of the following groups is tested separately with all other inputs using VIH = 2.6V, VIL = 0.4V: PA, PB, PC, Control Pins (Pins 5, 6, 8, 9, 35, 36).

Specifications HS-82C55ARH

TABLE 2. AC ELECTRICAL PERFORMANCE CHARACTERISTICS $T_A = -55^{\circ}\text{C}$ to $+125^{\circ}\text{C}$

PARAMETER	SYMBOL	CONDITIONS	SUB-GROUPS	TEMPERATURE	LIMITS		UNITS
					MIN	MAX	
READ							
Address Stable Before $\overline{\text{RD}}$	TAVRL	VDD = 4.5, 5.5V	9, 10, 11	-55°C, +25°C, +125°C	0	-	ns
Address Stable After $\overline{\text{RD}}$	TRHAX	VDD = 4.5, 5.5V	9, 10, 11	-55°C, +25°C, +125°C	0	-	ns
$\overline{\text{RD}}$ Pulse Width	TRLRH	VDD = 4.5, 5.5V	9, 10, 11	-55°C, +25°C, +125°C	250	-	ns
Data Valid From $\overline{\text{RD}}$	TRLDV	VDD = 4.5, 5.5V	9, 10, 11	-55°C, +25°C, +125°C	-	200	ns
Data Float After $\overline{\text{RD}}$	TRHDX	VDD = 4.5, 5.5V	9, 10, 11	-55°C, +25°C, +125°C	10	-	ns
Time Between $\overline{\text{RD}}$ s and/or $\overline{\text{WR}}$ s	TRWHRWL	VDD = 4.5, 5.5V	9, 10, 11	-55°C, +25°C, +125°C	300	-	ns
WRITE							
Address Stable Before $\overline{\text{WR}}$	TAVWL	VDD = 4.5, 5.5V	9, 10, 11	-55°C, +25°C, +125°C	0	-	ns
Address Stable After $\overline{\text{WR}}$	TWHAX	VDD = 4.5, 5.5V, Ports A and B	9, 10, 11	-55°C, +25°C, +125°C	20	-	ns
		VDD = 4.5, 5.5V, Port C	9, 10, 11	-55°C, +25°C, +125°C	100	-	ns
$\overline{\text{WR}}$ Pulse Width	TWLWH	VDD = 4.5, 5.5V	9, 10, 11	-55°C, +25°C, +125°C	100	-	ns
Data Valid to $\overline{\text{WR}}$ High	TDVWH	VDD = 4.5, 5.5V	9, 10, 11	-55°C, +25°C, +125°C	100	-	ns
Data Valid After $\overline{\text{WR}}$ High	TWHDX	VDD = 4.5, 5.5V, Ports A and B	9, 10, 11	-55°C, +25°C, +125°C	30	-	ns
		VDD = 4.5, 5.5V, Port C	9, 10, 11	-55°C, +25°C, +125°C	100	-	
OTHER TIMINGS							
$\overline{\text{WR}} = 1$ to Output	TWHPV	VDD = 4.5, 5.5V	9, 10, 11	-55°C, +25°C, +125°C	-	350	ns
Peripheral Data Before $\overline{\text{RD}}$	TPVRL	VDD = 4.5, 5.5V	9, 10, 11	-55°C, +25°C, +125°C	0	-	ns
Peripheral Data After $\overline{\text{RD}}$	TRHPX	VDD = 4.5, 5.5V	9, 10, 11	-55°C, +25°C, +125°C	0	-	ns
$\overline{\text{ACK}}$ Pulse Width	TKLKH	VDD = 4.5, 5.5V	9, 10, 11	-55°C, +25°C, +125°C	200	-	ns
$\overline{\text{STB}}$ Pulse Width	TSLSH	VDD = 4.5, 5.5V	9, 10, 11	-55°C, +25°C, +125°C	100	-	ns
Peripheral Data Before $\overline{\text{STB}}$ High	TPVSH	VDD = 4.5, 5.5V	9, 10, 11	-55°C, +25°C, +125°C	20	-	ns
Peripheral Data After $\overline{\text{STB}}$ High	TSHPX	VDD = 4.5, 5.5V	9, 10, 11	-55°C, +25°C, +125°C	50	-	ns
$\overline{\text{ACK}} = 0$ to Output	TKLPV	VDD = 4.5, 5.5V	9, 10, 11	-55°C, +25°C, +125°C	-	175	ns
$\overline{\text{ACK}} = 1$ to output Float	TKHPZ	VDD = 4.5, 5.5V	9, 10, 11	-55°C, +25°C, +125°C	10	-	ns

Specifications HS-82C55ARH

TABLE 2. AC ELECTRICAL PERFORMANCE CHARACTERISTICS $T_A = -55^{\circ}\text{C}$ to $+125^{\circ}\text{C}$ (Continued)

PARAMETER	SYMBOL	CONDITIONS	SUB-GROUPS	TEMPERATURE	LIMITS		UNITS
					MIN	MAX	
$\overline{WR} = 1$ to $\overline{OBF} = 0$	TWHOL	VDD = 4.5, 5.5V	9, 10, 11	-55°C , $+25^{\circ}\text{C}$, $+125^{\circ}\text{C}$	-	150	ns
$\overline{ACK} = 0$ to $\overline{OBF} = 1$	TKLOH	VDD = 4.5, 5.5V	9, 10, 11	-55°C , $+25^{\circ}\text{C}$, $+125^{\circ}\text{C}$	-	150	ns
$\overline{STB} = 0$ to $\text{IBF} = 1$	TSLIH	VDD = 4.5, 5.5V	9, 10, 11	-55°C , $+25^{\circ}\text{C}$, $+125^{\circ}\text{C}$	-	150	ns
$\overline{RD} = 1$ to $\text{IBF} = 0$	TRHIL	VDD = 4.5, 5.5V	9, 10, 11	-55°C , $+25^{\circ}\text{C}$, $+125^{\circ}\text{C}$	-	150	ns
$\overline{RD} = 0$ to $\text{INTR} = 1$	TRLNL	VDD = 4.5, 5.5V	9, 10, 11	-55°C , $+25^{\circ}\text{C}$, $+125^{\circ}\text{C}$	-	200	ns
$\overline{STB} = 1$ to $\text{INTR} = 1$	TSHNH	VDD = 4.5, 5.5V	9, 10, 11	-55°C , $+25^{\circ}\text{C}$, $+125^{\circ}\text{C}$	-	150	ns
$\overline{ACK} = 1$ to $\text{INTR} = 1$	TKHNL	VDD = 4.5, 5.5V	9, 10, 11	-55°C , $+25^{\circ}\text{C}$, $+125^{\circ}\text{C}$	-	150	ns
$\overline{WR} = 0$ to $\text{INTR} = 0$	TWLNL	VDD = 4.5, 5.5V	9, 10, 11	-55°C , $+25^{\circ}\text{C}$, $+125^{\circ}\text{C}$	-	200	ns
RESET Pulse Width	TRSHRSL	VDD = 4.5, 5.5V (Note 2)	9, 10, 11	-55°C , $+25^{\circ}\text{C}$, $+125^{\circ}\text{C}$	500	-	ns

NOTES:

- AC's tested at worst case VDD, guaranteed over full operating range.
- Period of initial RESET pulse after power-on must be at least 50 μs . Subsequent RESET pulses may be 500ns minimum.

TABLE 3. ELECTRICAL PERFORMANCE CHARACTERISTICS

PARAMETER	SYMBOL	CONDITIONS	TEMPERATURE	LIMITS		UNITS
				MIN	MAX	
Input Capacitance	CIN	VDD = Open, f = 1MHz, All measurements referenced to device ground	$T_A = +25^{\circ}\text{C}$	-	10	pF
I/O Capacitance	CI/O	VDD = Open, f = 1MHz, All measurements referenced to device ground	$T_A = +25^{\circ}\text{C}$	-	20	pF
Data Float After \overline{RD}	TRHDX	VDD = 4.5V and 5.5V	$-55^{\circ}\text{C} < T_A < +125^{\circ}\text{C}$	-	75	ns
$\overline{ACK} = 1$ to Output Float	TKHPZ	VDD = 4.5V and 5.5V	$-55^{\circ}\text{C} < T_A < +125^{\circ}\text{C}$	-	250	ns

NOTE: The parameters listed in Table 3 are controlled via design or process parameters and are not directly tested. These parameters are characterized upon initial design release and upon design changes which would affect these characteristics

TALBE 4. POST 100K RAD ELECTRICAL PERFORMANCE CHARACTERISTICS

See $+25^{\circ}\text{C}$ limits in Table 1 and Table 2 for Post RAD limits (Subgroups 1, 7, 9)

Specifications HS-82C55ARH

TABLE 5. BURN-IN DELTA PARAMETERS (+25°C)

PARAMETER	SYMBOL	DELTA LIMITS
Static Current	IDDSB	±10µA
Input Leakage Current	IIL, IIH	±200nA
Output Leakage Current	IOZL, IOZH	±2µA
Low Level Output Voltage	VOL	±80mV
TTL Output High Voltage	VOH1	±600mV
CMOS Output High Voltage	VOH2	±150mV

TABLE 6. APPLICABLE SUBGROUPS

CONFORMANCE GROUP	MIL-STD-883 METHOD	GROUP A SUBGROUPS			
		TESTED FOR -Q	RECORDED FOR -Q	TESTED FOR -8	RECORDED FOR -8
Initial Test	100% 5004	1, 7, 9	1 (Note 2)	1, 7, 9	
Interim Test	100% 5004	1, 7, 9, Δ	1, Δ (Note 2)	1, 7, 9	
PDA	100% 5004	1, 7, Δ	-	1, 7	
Final Test	100% 5004	2, 3, 8A, 8B, 10, 11	-	2, 3, 8A, 8B, 10, 11	
Group A (Note 1)	Sample 5005	1, 2, 3, 7, 8A, 8B, 9, 10, 11	-	1, 2, 3, 7, 8A, 8B, 9, 10, 11	
Subgroup B5	Sample 5005	1, 2, 3, 7, 8A, 8B, 9, 10, 11, Δ	1, 2, 3, Δ (Note 2)	N/A	
Subgroup B6	Sample 5005	1, 7, 9	-	N/A	
Group C	Sample 5005	N/A	N/A	1, 2, 3, 7, 8A, 8B, 9, 10, 11	
Group D	Sample 5005	1, 7, 9	-	1, 7, 9	
Group E, Subgroup 2	Sample 5005	1, 7, 9	-	1, 7, 9	

NOTES:

1. Alternate Group A testing in accordance with MIL-STD-883 method 5005 may be exercised.
2. Table 5 parameters only

Intersil Space Level Product Flow -Q

Wafer Lot Acceptance (All Lots) Method 5007 (Includes SEM)	100% Interim Electrical Test 1 (T1)
GAMMA Radiation Verification (Each Wafer) Method 1019, 2 Samples/Wafer, 0 Rejects	100% Delta Calculation (T0-T1)
100% Die Attach	100% PDA 1, Method 5004 (Note 1)
100% Nondestructive Bond Pull, Method 2023	100% Dynamic Burn-In, Condition D, 240 Hours, +125°C or Equivalent, Method 1015
Sample - Wire Bond Pull Monitor, Method 2011	100% Interim Electrical Test 2(T2)
Sample - Die Shear Monitor, Method 2019 or 2027	100% Delta Calculation (T0-T2)
100% Internal Visual Inspection, Method 2010, Condition A	100% PDA 2, Method 5004 (Note 1)
CSI and/or GSI PreCap (Note 6)	100% Final Electrical Test
100% Temperature Cycle, Method 1010, Condition C, 10 Cycles	100% Fine/Gross Leak, Method 1014
100% Constant Acceleration, Method 2001, Condition per Method 5004	100% Radiographic (X-Ray), Method 2012 (Note 2)
100% PIND, Method 2020, Condition A	100% External Visual, Method 2009
100% External Visual	Sample - Group A, Method 5005 (Note 3)
100% Serialization	Sample - Group B, Method 5005 (Note 4)
100% Initial Electrical Test (T0)	Sample - Group D, Method 5005 (Notes 4 and 5)
100% Static Burn-In 1, Condition A or B, 72 Hours Min, +125°C Min, Method 1015	100% Data Package Generation (Note 7)
	CSI and/or GSI Final (Note 6)

NOTES:

1. Failures from subgroup 1, 7 and deltas are used for calculating PDA. The maximum allowable PDA = 5% with no more than 3% of the failures from subgroup 7.
2. Radiographic (X-Ray) inspection may be performed at any point after serialization as allowed by Method 5004.
3. Alternate Group A testing may be performed as allowed by MIL-STD-883, Method 5005.
4. Group B and D inspections are optional and will not be performed unless required by the P.O. When required, the P.O. should include separate line items for Group B Test, Group B Samples, Group D Test and Group D Samples.
5. Group D Generic Data, as defined by MIL-I-38535, is optional and will not be supplied unless required by the P.O. When required, the P.O. should include a separate line item for Group D Generic Data. Generic data is not guaranteed to be available and is therefore not available in all cases.
6. CSI and/or GSI inspections are optional and will not be performed unless required by the P.O. When required, the P.O. should include separate line items for CSI PreCap inspection, CSI final inspection, GSI PreCap inspection, and/or GSI final inspection.
7. Data Package Contents:
 - Cover Sheet (Intersil Name and/or Logo, P.O. Number, Customer Part Number, Lot Date Code, Intersil Part Number, Lot Number, Quantity).
 - Wafer Lot Acceptance Report (Method 5007). Includes reproductions of SEM photos with percent of step coverage.
 - GAMMA Radiation Report. Contains Cover page, disposition, Rad Dose, Lot Number, Test Package used, Specification Numbers, Test equipment, etc. Radiation Read and Record data on file at Intersil.
 - X-Ray report and film. Includes penetrometer measurements.
 - Screening, Electrical, and Group A attributes (Screening attributes begin after package seal).
 - Lot Serial Number Sheet (Good units serial number and lot number).
 - Variables Data (All Delta operations). Data is identified by serial number. Data header includes lot number and date of test.
 - Group B and D attributes and/or Generic data is included when required by the P.O.
 - The Certificate of Conformance is a part of the shipping invoice and is not part of the Data Book. The Certificate of Conformance is signed by an authorized Quality Representative.

Intersil Space Level Product Flow -8

GAMMA Radiation Verification (Each Wafer) Method 1019,
2 Samples/Wafer, 0 Rejects

100% Die Attach

Periodic- Wire Bond Pull Monitor, Method 2011

Periodic- Die Shear Monitor, Method 2019 or 2027

100% Internal Visual Inspection, Method 2010, Condition B

CSI an/or GSI PreCap (Note 5)

100% Temperature Cycle, Method 1010, Condition C,
10 Cycles

100% Constant Acceleration, Method 2001, Condition per
Method 5004

100% External Visual

100% Initial Electrical Test

100% Dynamic Burn-In, Condition D, 160 Hours, +125°C or
Equivalent, Method 1015

100% Interim Electrical Test

100% PDA, Method 5004 (Note 1)

100% Final Electrical Test

100% Fine/Gross Leak, Method 1014

100% External Visual, Method 2009

Sample - Group A, Method 5005 (Note 2)

Sample - Group B, Method 5005 (Note 3)

Sample - Group C, Method 5005 (Notes 3 and 4)

Sample - Group D, Method 5005 (Notes 3 and 4)

100% Data Package Generation (Note 6)

CSI and/or GSI Final (Note 5)

NOTES:

1. Failures from subgroup 1, 7 are used for calculating PDA. The maximum allowable PDA = 5%.
2. Alternate Group A testing may be performed as allowed by MIL-STD-883, Method 5005.
3. Group B, C and D inspections are optional and will not be performed unless required by the P.O. When required, the P.O. should include separate line items for Group B Test, Group C Test, Group C Samples, Group D Test and Group D Samples.
4. Group C and/or Group D Generic Data, as defined by MIL-I-38535, is optional and will not be supplied unless required by the P.O. When required, the P.O. should include a separate line item for Group C Generic Data and/or Group D Generic Data. Generic data is not guaranteed to be available and is therefore not available in all cases.
5. CSI and/or GSI inspections are optional and will not be performed unless required by the P.O. When required, the P.O. should include separate line items for CSI PreCap inspection, CSI final inspection, GSI PreCap inspection, and/or GSI final inspection.
6. Data Package Contents:
 - Cover Sheet (Intersil Name and/or Logo, P.O. Number, Customer Part Number, Lot Date Code, Intersil Part Number, Lot Number, Quantity).
 - GAMMA Radiation Report. Contains Cover page, disposition, Rad Dose, Lot Number, Test Package used, Specification Numbers, Test equipment, etc. Radiation Read and Record data on file at Intersil.
 - Screening, Electrical, and Group A attributes (Screening attributes begin after package seal).
 - Group B, C and D attributes and/or Generic data is included when required by the P.O.
 - The Certificate of Conformance is a part of the shipping invoice and is not part of the Data Book. The Certificate of Conformance is signed by an authorized Quality Representative.

AC Test Circuit

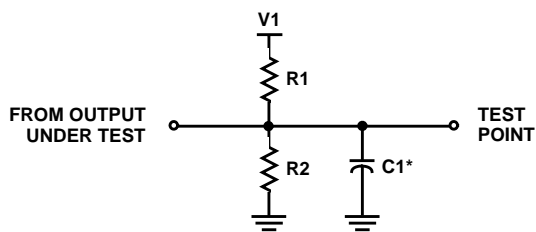

* Includes stray and jig capacitance

TEST CONDITIONS DEFINITION TABLE

V1	R1	R2	C1
1.7V	523Ω	Open	150pF

AC Testing Input, Output Waveforms



NOTE: AC Testing: All parameters tested as per test circuits. Input rise and fall times are driven at 1V/ns.

Waveforms

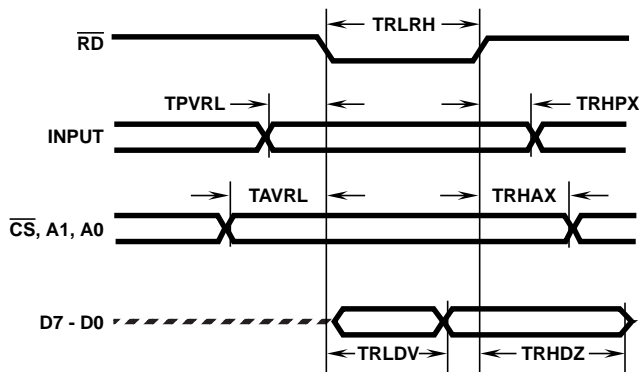

FIGURE 1. MODE 0 (BASIC INPUT)

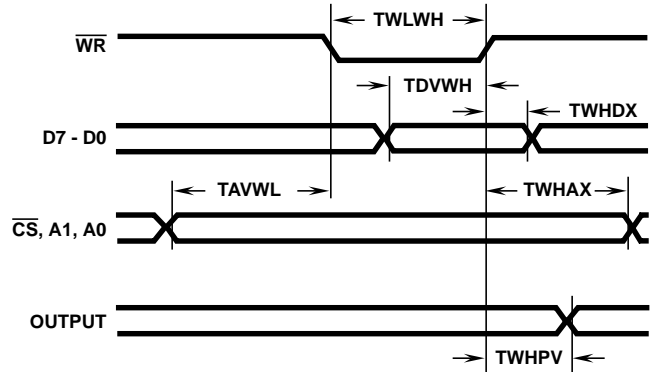

FIGURE 2. MODE 0 (BASIC OUTPUT)

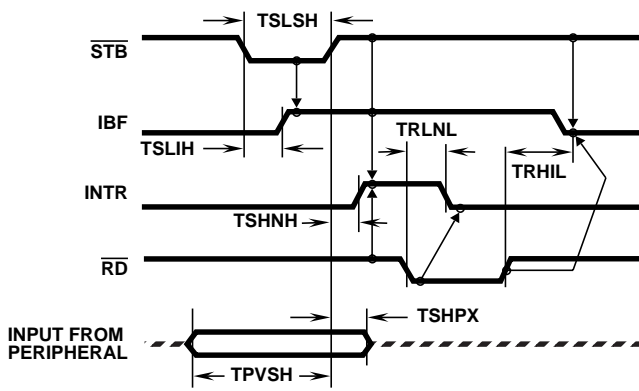

FIGURE 3. MODE 1 (STROBED INPUT)

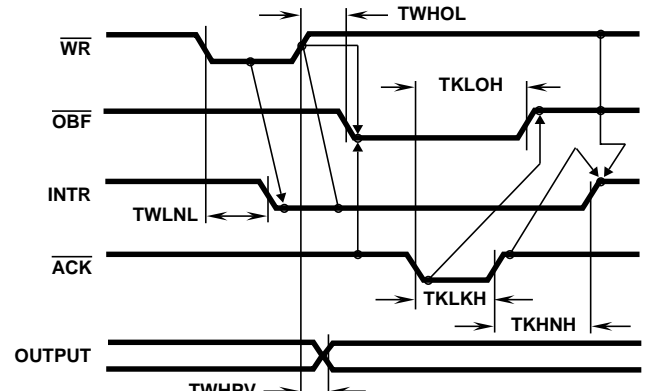

FIGURE 4. MODE 1 (STROBED OUTPUT)

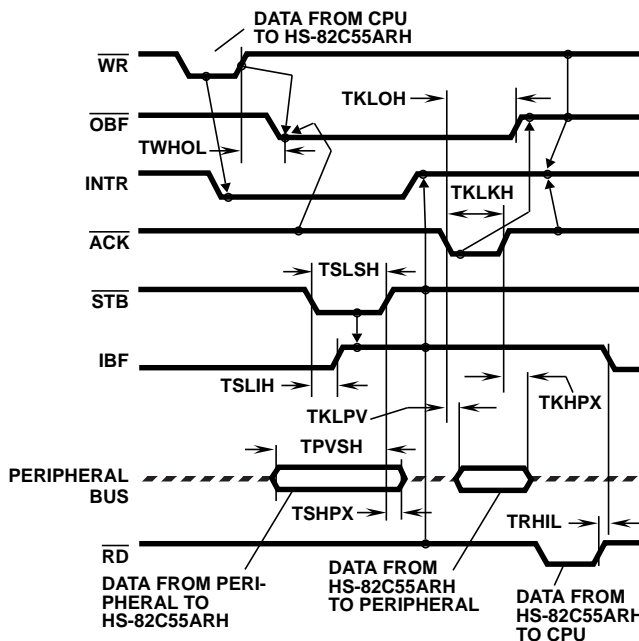

FIGURE 5. MODE 2 (BIDIRECTIONAL)

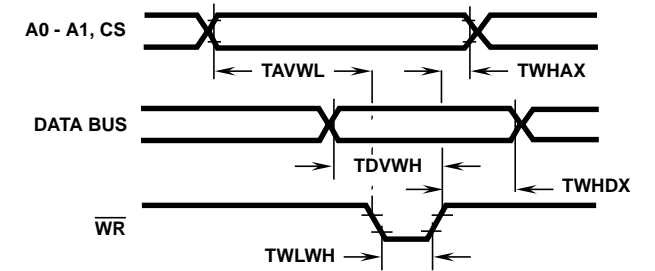

FIGURE 6. WRITE TIMING

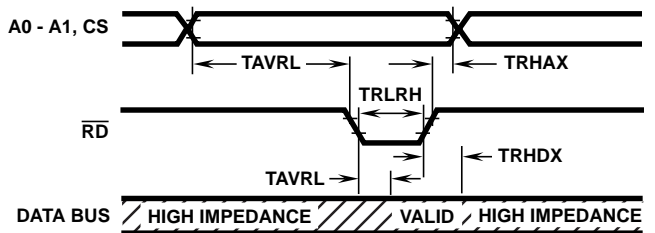
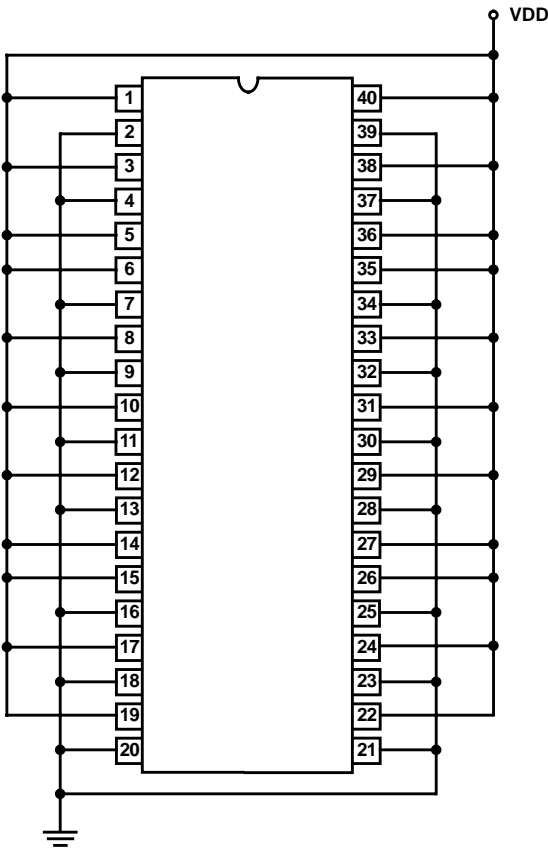

FIGURE 7. READ TIMING

NOTE: Any sequence where \overline{WR} occurs before \overline{ACK} and \overline{STB} occurs before \overline{RD} is permissible.

Burn-In Circuits

PROGRAMMABLE PERIPHERAL INTERFACE



STATIC CONFIGURATION

NOTES:

1. $V_{DD} = 6.0V \pm 0.5\%$
2. $I_{DD} < 500\mu A$
3. $T_A \text{ Min} = +125^\circ C$

PROGRAMMABLE PERIPHERAL INTERFACE

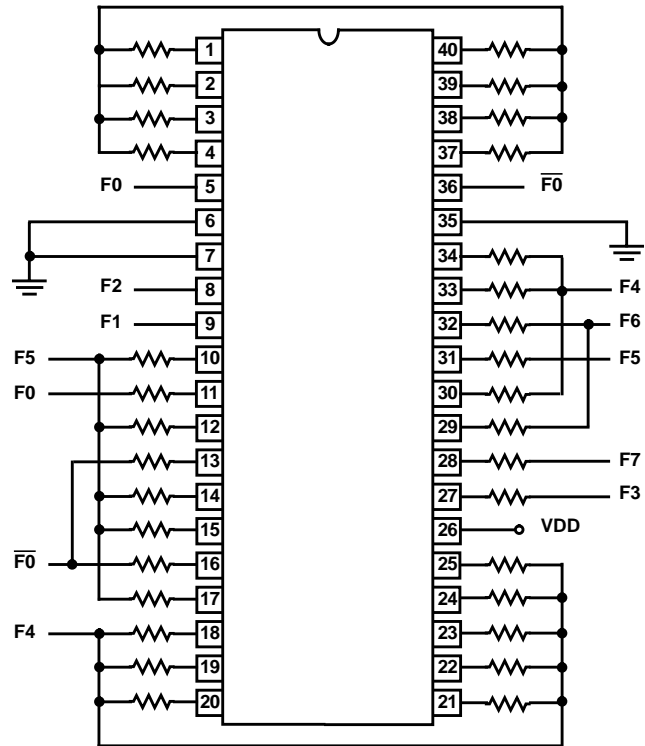

DYNAMIC CONFIGURATION

NOTES:

1. $V_{DD} = 6.0V \pm 5\%$ for Burn-In
2. $V_{DD} = 5.0V \pm 5\%$ for Life Test
3. All resistors are $10K\Omega \pm 5\%$
4. $-0.3V \leq V_{IL} \leq 0.8V$
5. $V_{DD} - 1.0V \leq V_{IH} \leq V_{DD}$
6. $I_{DD} < 5mA$
7. $F_0 = 10KHz, 50\%$ Duty cycle
8. $F_1 = F_0/2; F_2 = F_1/2; F_3 = F_2/2; F_4 = F_3/2 \dots F_7 = F_6/2$
9. $T_A \text{ Min} = +125^\circ C$

HS-82C55ARH

Irradiation Circuit

CMOS PROGRAMMABLE PERIPHERAL INTERFACE

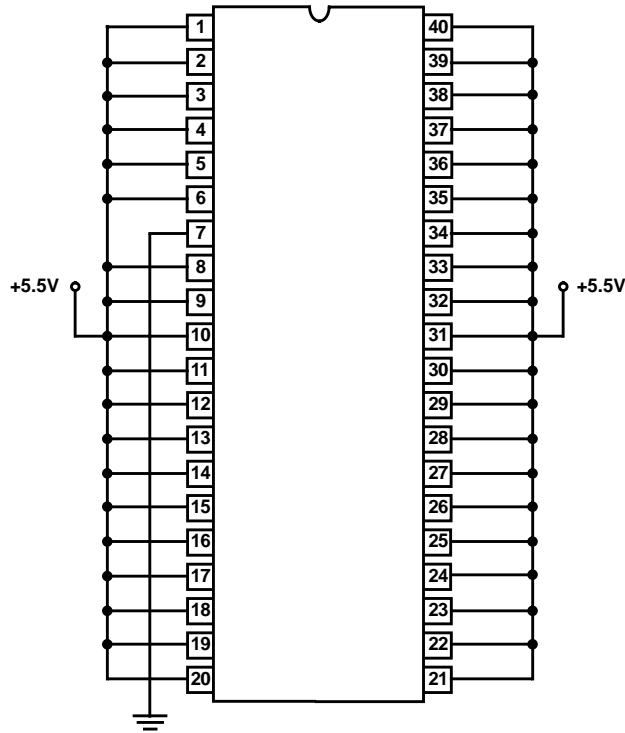

NOTE:

1. VDD = 5.5V

Functional Description

The HS-82C55ARH is a programmable peripheral interface designed to allow microcomputer systems to control and interface with all types of peripheral devices. It has the ability to generate and respond to all asynchronous handshaking signals necessary to transfer data to and from peripheral devices, and it can also interrupt the processor when a peripheral needs servicing. These capabilities allow the HS-82C55ARH to be used in an unlimited number of applications including EXTERNAL SYSTEM CONTROL, ASYNCHRONOUS DATA TRANSFER, and SYSTEMS MONITORING.

Data Bus Buffer

This tri-state bidirectional 8-bit buffer is used to interface the HS-82C55ARH to the system data bus (see Figure 8). Data is transmitted or received by the buffer upon execution of input or output instructions by the CPU. Control words and status information are also transferred through the data bus buffer.

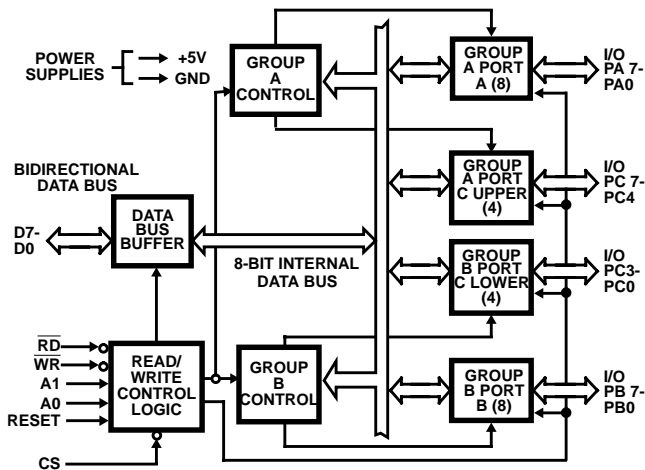

FIGURE 8. BLOCK DIAGRAM DATA BUS BUFFER, READ/WRITE, GROUP A AND B CONTROL LOGIC FUNCTIONS

Read/Write and Control Logic

The function of this block is to manage all of the internal and external transfer of both Data and Control or Status words. It accepts inputs from the CPU Address and Control busses and in turn, issues commands to both of the Control Groups.

Group A and Group B Controls

The functional configuration of each port is programmed by the systems software. In essence, the CPU writes a control word to the HS-82C55ARH. The control word contains information such as "mode", "bit set", "bit reset", etc., that initializes the functional configuration of the HS-82C55ARH.

Each of the Control blocks (Group A and Group B) accepts "commands" from the Read/Write Control Logic, receives "control words" from the internal data bus and issues the proper commands to its associated ports.

- Control Group - Port A and Port C upper (C7 - C4)
- Control Group - Port B and Port C lower (C3 - C0).

Ports A, B, C

The HS-82C55ARH contains three 8-bit ports (A, B and C). All can be configured to a wide variety of functional characteristics by the system software but each has its own special features or "personality" to further enhance the power and flexibility of the HS-82C55ARH.

- Port A One 8-bit data output latch/buffer and one 8-bit data input latch. Both "pull-up" and "pull-down" bus hold devices are present on Port A. See Figure 9A.
- Port B One 8-bit data input/output latch/buffer and one 8-bit data input buffer. See Figure 9B.
- Port C One 8-bit data output latch/buffer and one 8-bit data input buffer (no latch for input). This port can be divided into two 4-bit ports under the mode control. Each 4-bit port contains a 4-bit latch and can be used for the control signal outputs and status signal inputs in conjunction with Ports A and B. See Figure 9B.

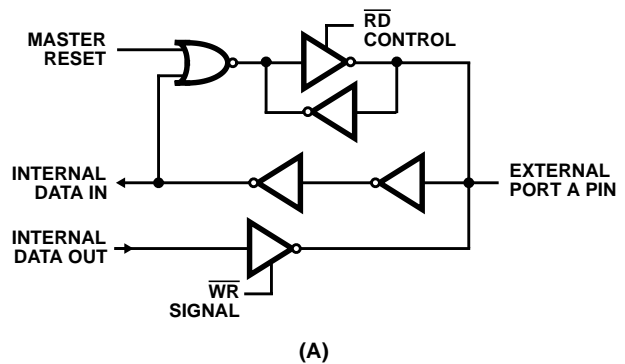

(A)

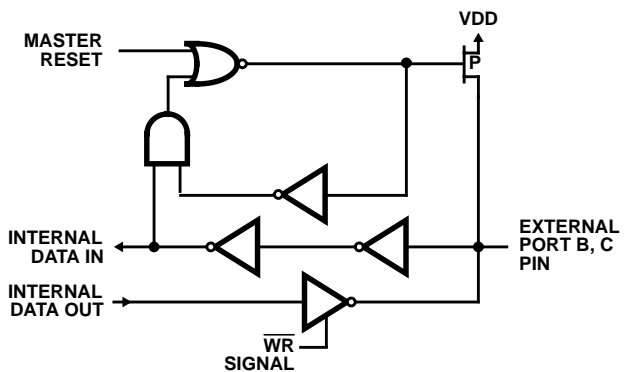

(B)

FIGURE 9. I/O PORT CONFIGURATION

Operational Description

Control Word

The data direction and mode of Ports A, B and C are determined by the contents of the Control Word. See Figure 11. The Control Word can be both written and read as shown in Table 1 and 2. During write operations, the function of the Control Word being written is determined by data bit D7. If D7 is low, the data on D0 - D3 will set or reset one of the bits of Port C. See Figure 12. During read Operations, the

Control Word will always be in the format illustrated in Figure 11 with Bit D7 high to indicate Control Word Mode Information.

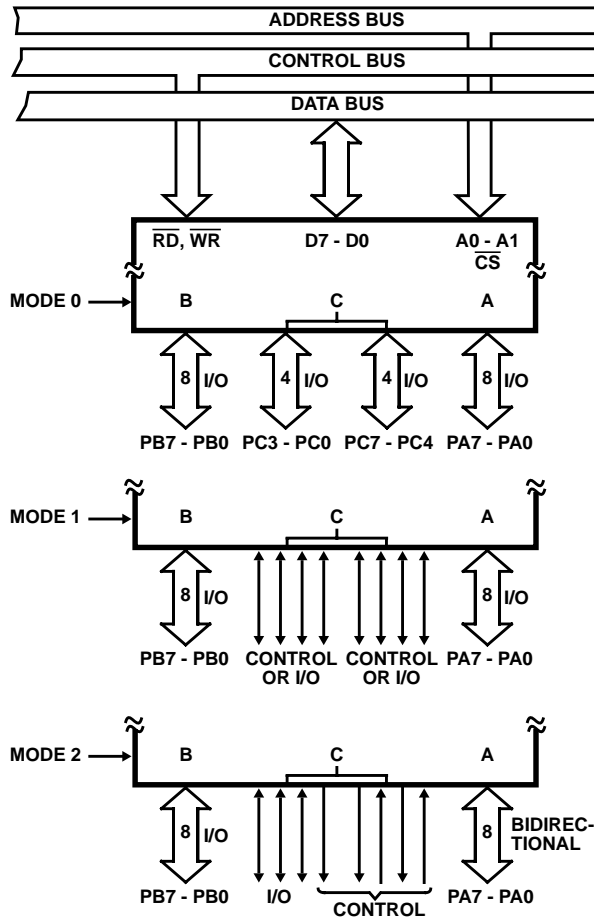

FIGURE 10. BASIC MODE DEFINITIONS & BUS INTERFACE

TABLE 1.

A1	A0	\overline{RD}	\overline{WR}	\overline{CS}	INPUT OPERATION (READ)
0	0	0	1	0	Port A - Data Bus
0	1	0	1	0	Port B - Data Bus
1	0	0	1	0	Port C - Data Bus
1	1	0	1	0	Control Word - Data Bus

TABLE 2.

A1	A0	\overline{RD}	\overline{WR}	\overline{CS}	OUTPUT OPERATION (WRITE)
0	0	1	0	0	Data Bus - Port A
0	1	1	0	0	Data Bus - Port B
1	0	1	0	0	Data Bus - Port C
1	1	1	0	0	Data Bus - Control Word

TABLE 3.

A1	A0	\overline{RD}	\overline{WR}	\overline{CS}	DISABLE FUNCTION
X	X	X	X	1	Data Bus - 3-State
X	X	1	1	0	Data Bus - 3-State

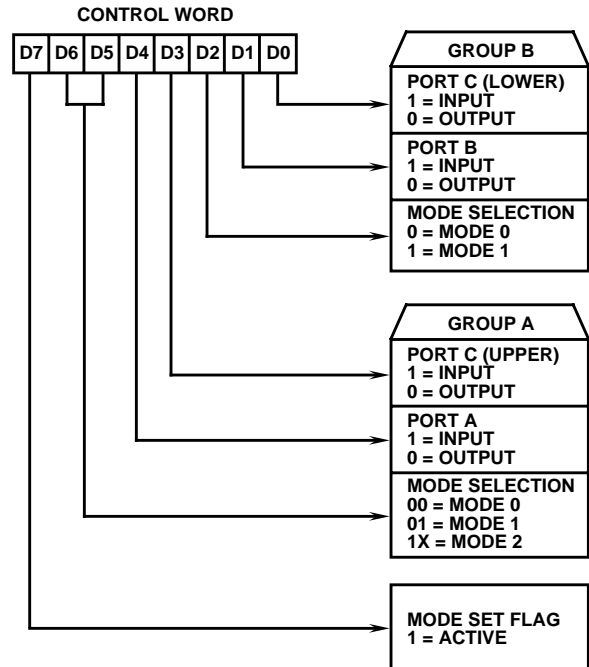

FIGURE 11. MODE SET CONTROL WORD FORMAT

Mode Selection

There are three basic modes of operation that can be selected by the system software:

- Mode 0 - Basic Input/Output
- Mode 1 - Strobed Input/Output
- Mode 2 - Bidirectional Bus

When the RESET input goes "high", all ports will be set to the input mode with all 24 port lines held at the logic "one" level by internal bus hold devices. After reset, the HS-82C55ARH can remain in the input mode with no additional initialization required. This eliminates the need for pullup or pulldown resistors in all CMOS designs. During the execution of the system program, any of the other modes may be selected using a single output instruction. This allows a single HS-82C55ARH to service a variety of peripheral devices with a simple software maintenance routine.

The modes for Port A and Port B can be separately defined while Port C is divided into two portions as required by the Port A and Port B definitions. All of the output registers, including the status register, will be reset whenever the mode is changed. Modes may be combined so that their functional definition can be "tailored" to almost any I/O structure. For instance: Group B can be programmed in Mode 0 to monitor simple switch closings or display computational results, Group A could be programmed in Mode 1 to monitor a keyboard or tape recorder on an interrupt-driven basis.

The mode definitions and possible mode combinations may seem confusing at first but after a cursory review of the complete device operation a simple, logical I/O approach will surface. The design of the HS-82C55ARH has taken into account things such as efficient PC board layout, control signal definition vs PC layout and complete functional flexibility to support almost any peripheral device with no external logic. Such design represents the maximum use of the available pins.

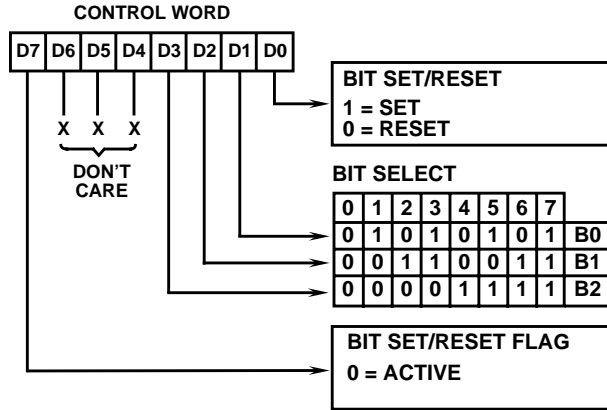

FIGURE 12. BIT SET/RESET CONTROL WORD FORMAT

Single Bit/Set/Reset Feature

Any of the eight bits of Port C can be Set or Reset using a single OUTput instruction. See Figure 12. This feature reduces software requirements in control-based applications.

Interrupt Control Functions

When the HS-82C55ARH is programmed to operate in Mode 1 or Mode 2, control signals are provided that can be used as interrupt request inputs to the CPU. The interrupt request signals, generated from Port C, can be inhibited or enable by setting or resetting the associated INTE flip-flop, using the Bit Set/Reset function of Port C.

This function allows the programmer to enable or disable a CPU interrupt by a specific I/O device without affecting any other device in the interrupt structure.

INTE Flip-Flop Definition:

(BIT-SET) - INTE is SET - Interrupt enable.

(BIT-RESET) - INTE is RESET - Interrupt disable.

NOTE: All mask flip-flops are automatically reset during mode selection and device Reset.

Operating Modes

Mode 0 (Basic Input/Output)

This functional configuration provides simple input and output operations for each of the three ports. No handshaking is required, data is simply written to or read from a specific port.

Mode 0 Basic Functional Definitions:

- Two 8-bit ports and two 4-bit ports
- Any port can be input or output
- Outputs are latched
- Inputs are not latched
- 16 different Input/Output configurations possible

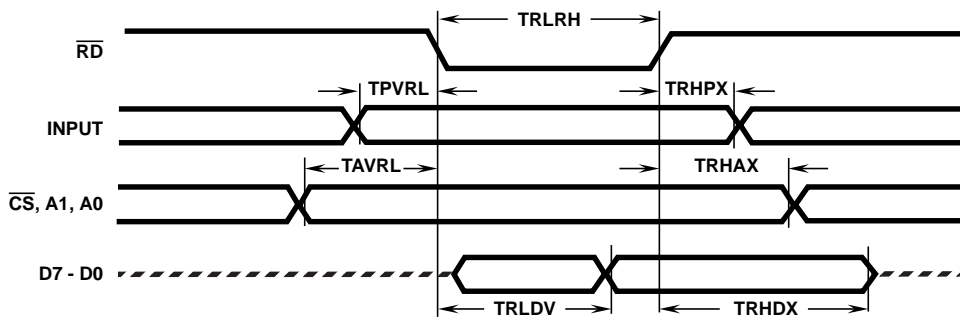

FIGURE 13. MODE 0 (BASIC INPUT)

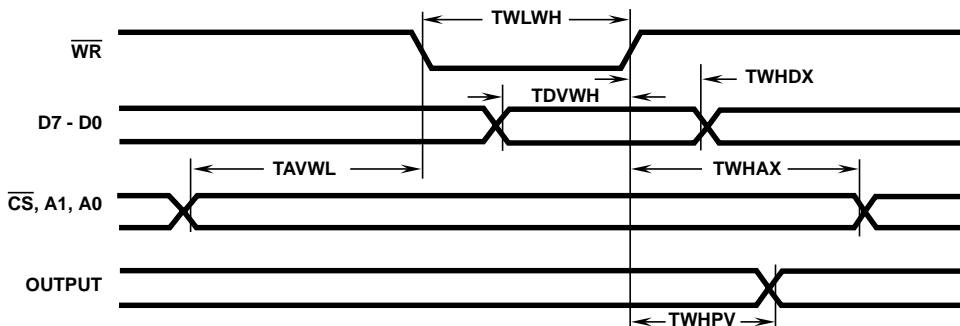

FIGURE 14. MODE 0 (BASIC OUTPUT)

Mode 0 Port Definition

A		B		GROUP A		NO.	GROUP B	
D4	D3	D1	D0	PORT A	PORT C (UPPER)		PORT B	PORT C (LOWER)
0	0	0	0	Output	Output	0	Output	Output
0	0	0	1	Output	Output	1	Output	Input
0	0	1	0	Output	Output	2	Input	Output
0	0	1	1	Output	Output	3	Input	Input
0	1	0	0	Output	Input	4	Output	Output
0	1	0	1	Output	Input	5	Output	Input
0	1	1	0	Output	Input	6	Input	Output
0	1	1	1	Output	Input	7	Input	Input
1	0	0	0	Input	Output	8	Output	Output
1	0	0	1	Input	Output	9	Output	Input
1	0	1	0	Input	Output	10	Input	Output
1	0	1	1	Input	Output	11	Input	Input
1	1	0	0	Input	Input	12	Output	Output
1	1	0	1	Input	Input	13	Output	Input
1	1	1	0	Input	Input	14	Input	Output
1	1	1	1	Input	Input	15	Input	Input

Mode 0 Configurations

CONTROL WORD #0

D7	D6	D5	D4	D3	D2	D1	D0
1	0	0	0	0	0	0	0

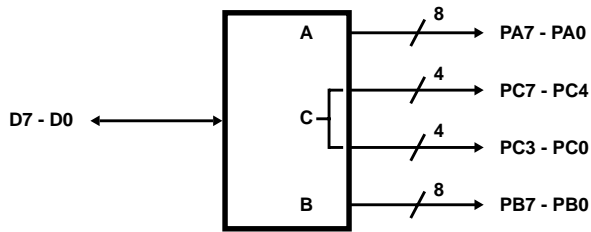

CONTROL WORD #1

D7	D6	D5	D4	D3	D2	D1	D0
1	0	0	0	0	0	0	1

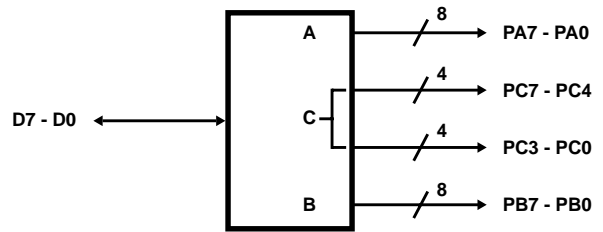

CONTROL WORD #2

D7	D6	D5	D4	D3	D2	D1	D0
1	0	0	0	0	0	1	0

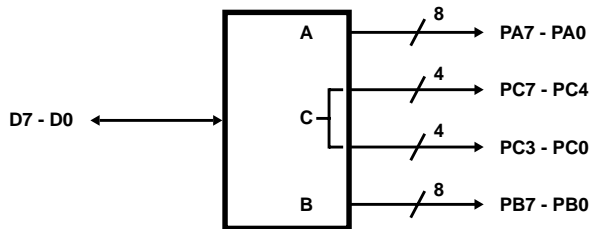

CONTROL WORD #3

D7	D6	D5	D4	D3	D2	D1	D0
1	0	0	0	0	0	1	1

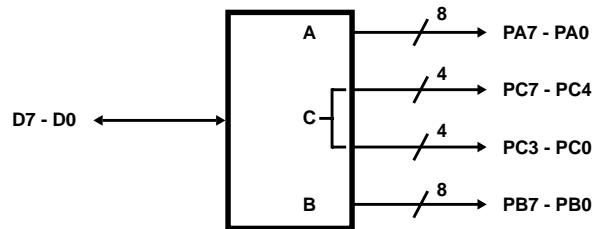

Mode 0 Configurations (Continued)

CONTROL WORD #4

D7	D6	D5	D4	D3	D2	D1	D0
1	0	0	0	1	0	0	0

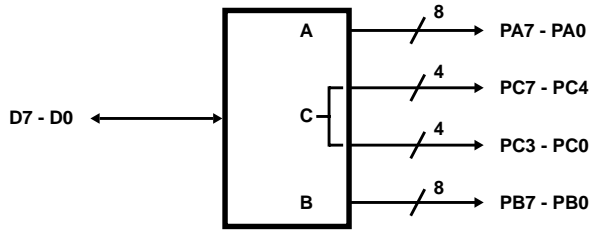

CONTROL WORD #5

D7	D6	D5	D4	D3	D2	D1	D0
1	0	0	1	1	0	0	1

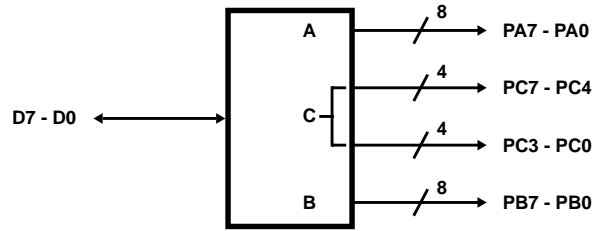

CONTROL WORD #6

D7	D6	D5	D4	D3	D2	D1	D0
1	0	0	0	1	0	1	0

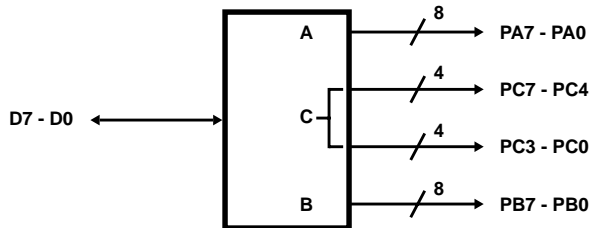

CONTROL WORD #7

D7	D6	D5	D4	D3	D2	D1	D0
1	0	0	0	1	0	1	1

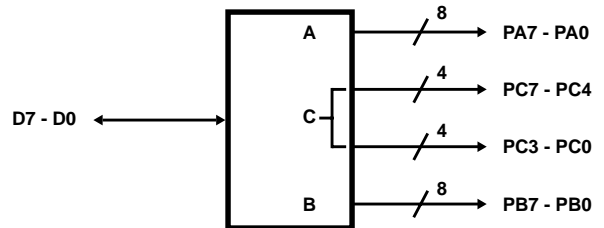

CONTROL WORD #8

D7	D6	D5	D4	D3	D2	D1	D0
1	0	0	1	0	0	0	0

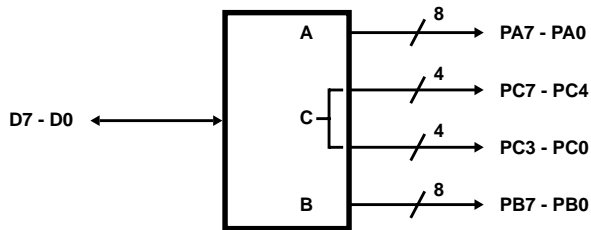

CONTROL WORD #9

D7	D6	D5	D4	D3	D2	D1	D0
1	0	0	1	0	0	0	1

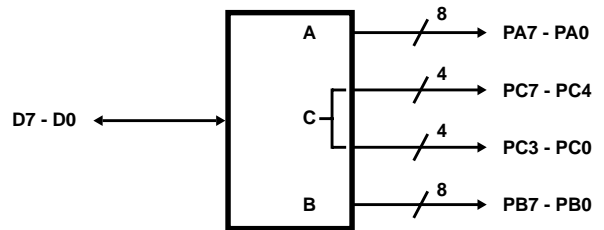

CONTROL WORD #10

D7	D6	D5	D4	D3	D2	D1	D0
1	0	0	1	0	0	1	0

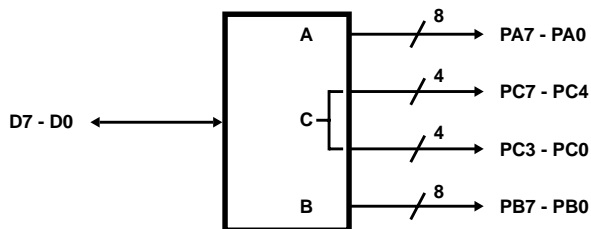

CONTROL WORD #11

D7	D6	D5	D4	D3	D2	D1	D0
1	0	0	1	0	0	1	1

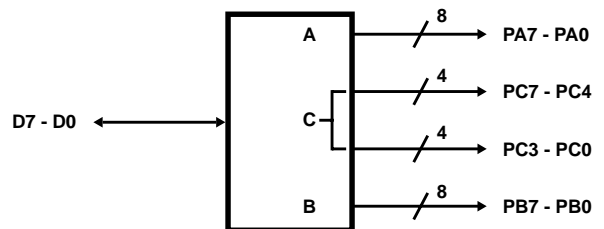

Mode 0 Configurations (Continued)

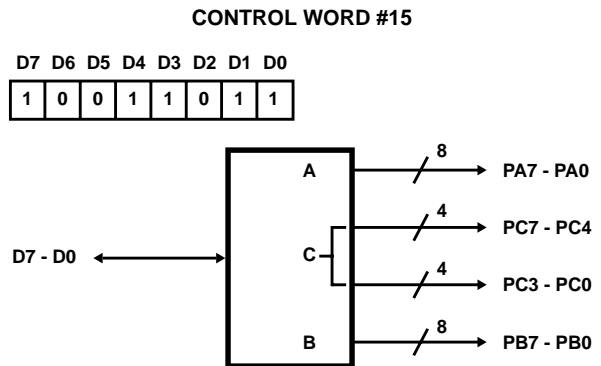
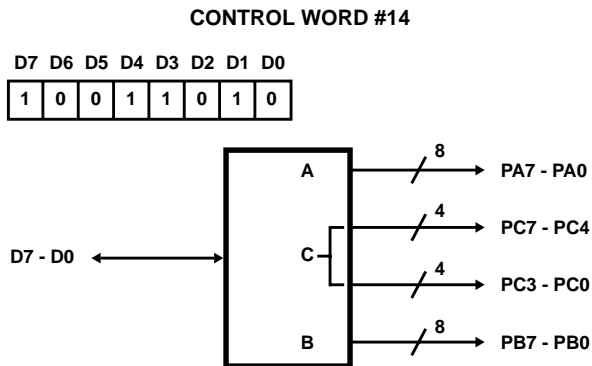
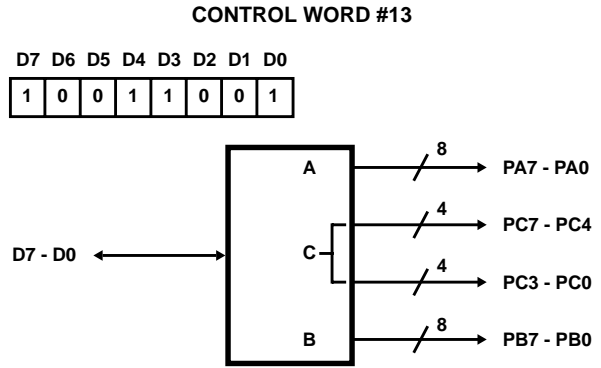
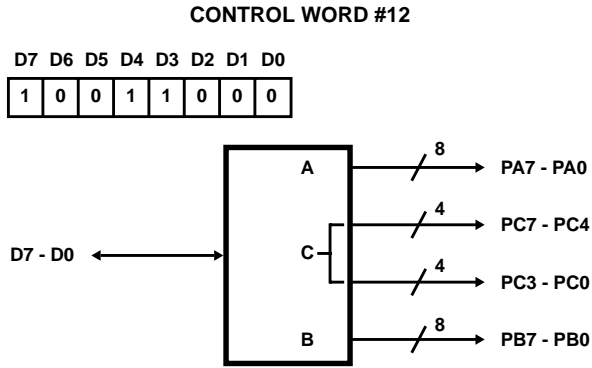

Operating Modes

Mode 1 (Strobed Input/Output)

This functional configuration provides a means for transferring I/O data to or from a specified port in conjunction with strobes or "handshaking" signals. In Mode 1, Port A and Port B use the lines on Port C to generate or accept these "handshaking" signals.

Mode 1 Basic Functional Definitions:

- Two Groups (Group A and Group B)
- Each group contains one 8-bit port and one 4-bit control/data port.
- The 8-bit data port can be either input or output. Both inputs and outputs are latched.
- The 4-bit port is used for control and status of the 8-bit port.

Input Control Signal Definition

STB (Strobe Input)

A "low" on this input loads data into the input latch.

IBF (Input Buffer Full F/F)

A "high" on this output indicates that the data has been loaded into the input latch; in essence, an acknowledgment. IBF is set by \overline{STB} input being low and is reset by the rising edge of the \overline{RD} input.

INTR (Interrupt Request)

A "high" on this output can be used to interrupt the CPU when an input device is requesting service. INTR is set by the rising edge of \overline{STB} and reset by the falling edge of \overline{RD} . This procedure allows an input device to request service from the CPU by simply strobing its data into the port.

INTE A

Controlled by Bit Set/Reset of PC4.

INTE B

Controlled by Bit Set/Reset of PC2.

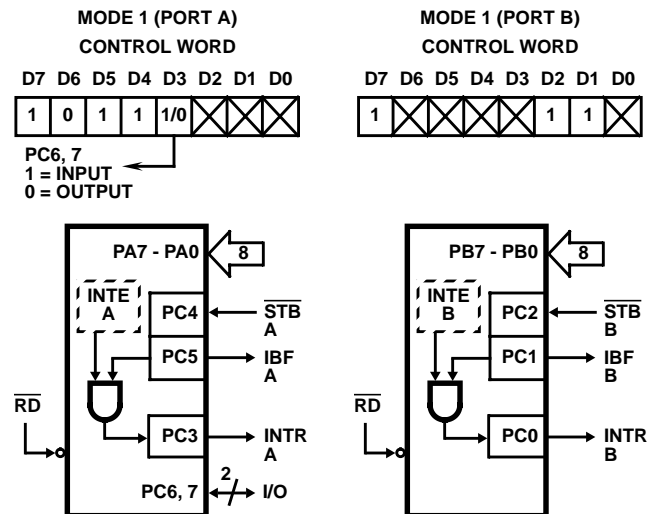

FIGURE 15. MODE 1 INPUT

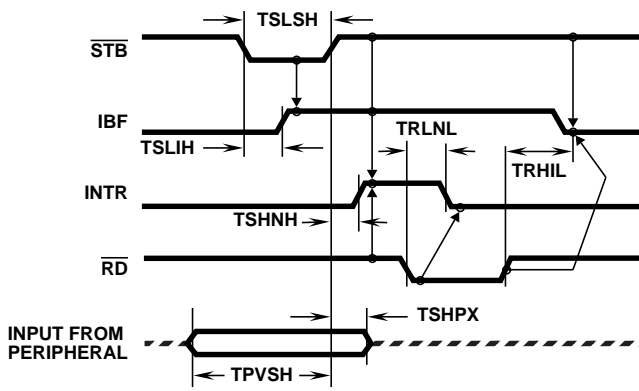

FIGURE 16. MODE 1 (STROBED INPUT)

Output Control Signal Definition

OBF (Output Buffer Full F/F)

The OBF output will go "low" to indicate that the CPU has written data out to the specified port. This does not mean valid data is sent out of the port at this time since OBF can go true before data is available. Data is guaranteed valid at the rising edge of OBF. See Note 1. The OBF F/F will be set by the rising edge of the WR input and reset by ACK input being low.

ACK (Acknowledge Input)

A "low" on this input informs the HS-82C55ARH that the data from Port A or Port B is ready to be accepted. In essence, a response from the peripheral device indicating that it is ready to accept data. See Note 1.

INTR (Interrupt Request)

A "high" on this output can be used to interrupt the CPU when an output device has accepted data transmitted by the CPU. INTR is set by the rising edge of ACK and reset by the falling edge of WR.

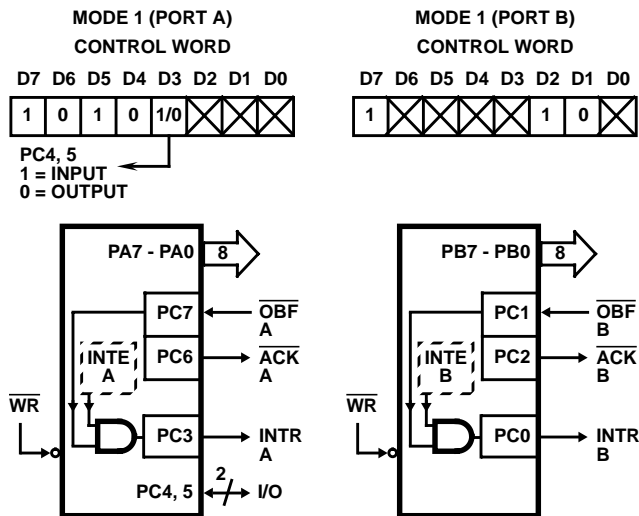

FIGURE 17. MODE 1 OUTPUT

INTE A

Controlled by Bit Set/Reset of PC6.

INTE B

Controlled by Bit Set/Reset of PC2.

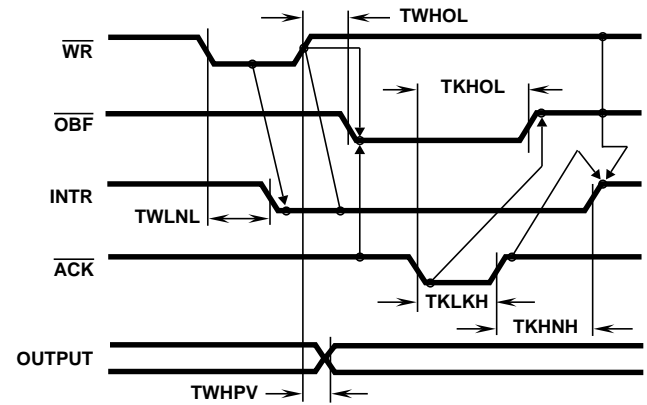

FIGURE 18. MODE 1 (STROBED OUTPUT)

NOTE:

- To strobe data into the peripheral device, the user must operate the strobe line in a hand shaking mode. The user needs to send \overline{OBF} to the peripheral device, generate an \overline{ACK} from the peripheral device and then latch data into the peripheral device on the rising edge of \overline{OBF} .

Combinations of Mode 1: Port A and Port B can be individually defined as input or output in Mode 1 to support a wide variety of strobed I/O applications.

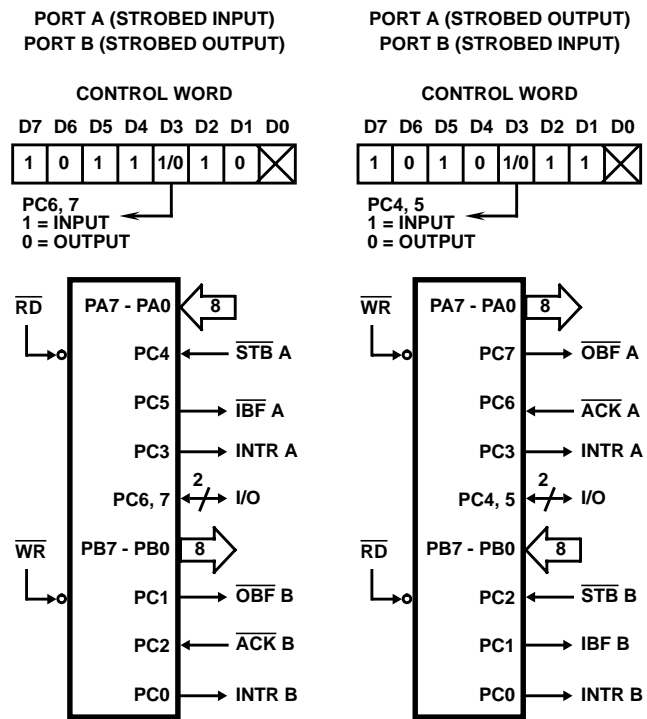

FIGURE 19. COMBINATIONS OF MODE 1

Operating Modes

MODE 2 (Strobed Bidirectional Bus I/O)

The functional configuration provides a means for communicating with a peripheral device or structure on a single 8-bit bus for both transmitting and receiving data (bidirectional bus I/O). "Handshaking" signals are provided to maintain proper bus flow discipline similar to MODE 1. Interrupt generation and enable/disable functions are also available.

Mode 2 Basic Functional Definitions:

- Used in Group A only.
- One 8-bit, bidirectional bus port (Port A) and a 5-bit control port (Port C).
- Both inputs and outputs are latched.
- The 5-bit control port (Port C) is used for control and status for the 8-bit, bidirectional bus port (Port A).

Bidirectional Bus I/O Control Signal Definition

INTR (Interrupt Request)

A high on this output can be used to interrupt the CPU for both input or output operations. INTR will be set either by the rising edge of \overline{ACK} (INTE1 = 1) or the rising edge of \overline{STB} (INTE2 = 1). INTR will be reset by the falling edge of \overline{WR} (if previously set by the rising edge or \overline{ACK}), the falling edge of \overline{RD} (if previously set by the rising edge of \overline{STB}), or the falling edge of \overline{WR} when immediately following a low \overline{RD} pulse or the falling edge of \overline{RD} when immediately following a low \overline{WR} pulse (if previously set by the rising edges of both \overline{ACK} and \overline{STB}).

Output Operations

\overline{OBF} (Output Buffer Full)

The \overline{OBF} output will go "low" to indicate that the CPU has written data out to Port A.

\overline{ACK} (Acknowledge)

A "low" on this input enables the tri-state output buffer of Port A to send out the data. Otherwise, the output buffer will be in the high impedance state.

INTE 1 (The INTE Flip-Flop Associated with \overline{OBF})

Controlled by Bit Set/Reset of PC6.

Input Operations

\overline{STB} (Strobe Input)

A "low" on this input loads data into the input latch.

IBF (Input Buffer Full F/F)

A "high" on this output indicates that data has been loaded into the input latch.

INTE 2 (The INTE Flip-Flop Associated with IBF)

Controlled by Bit Set/Reset of PC4.

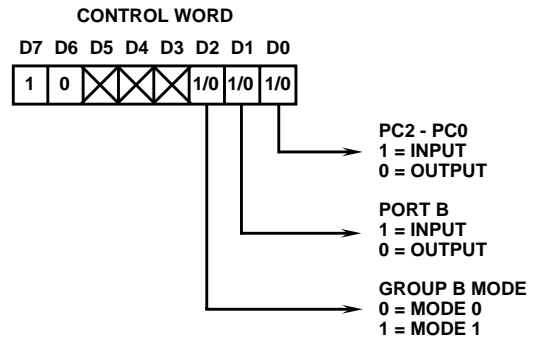

FIGURE 20. MODE CONTROL WORD

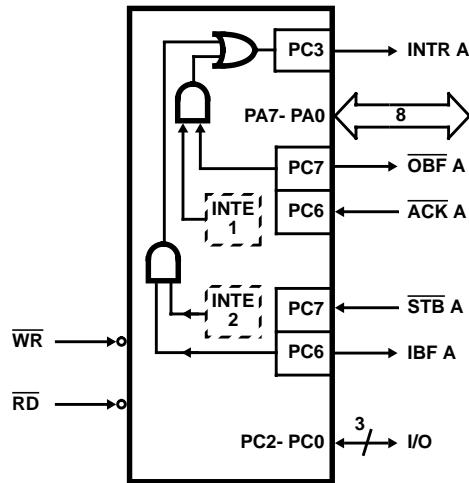
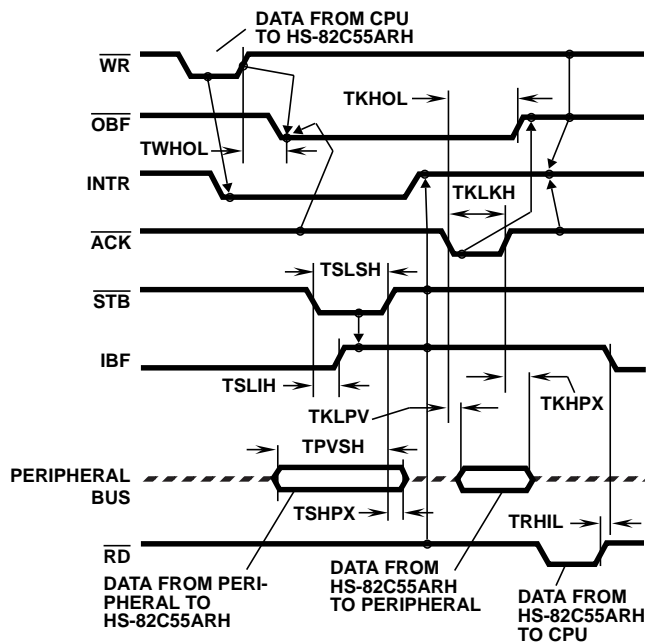

FIGURE 21. MODE 2 (BIDIRECTIONAL)



NOTE: Any sequence where \overline{WR} occurs before \overline{ACK} and \overline{STB} occurs before \overline{RD} is permissible.

FIGURE 22. MODE 2 (BIDIRECTIONAL)

MODE DEFINITION SUMMARY

	MODE 0		MODE 1		MODE 2
	IN	OUT	IN	OUT	GROUP A ONLY
PA0	In	Out	In	Out	↔
AP1	In	Out	In	Out	↔
PA2	In	Out	In	Out	↔
PA3	In	Out	In	Out	↔
PA4	In	Out	In	Out	↔
PA5	In	Out	In	Out	↔
PA6	In	Out	In	Out	↔
PA7	In	Out	In	Out	↔
PB0	In	Out	In	Out	-
PB1	In	Out	In	Out	-
PB2	In	Out	In	Out	-
PB3	In	Out	In	Out	-
PB4	In	Out	In	Out	-
PB5	In	Out	In	Out	-
PB6	In	Out	In	Out	-
PB7	In	Out	In	Out	-
PC0	In	Out	INTR B	INTR B	I/O
PC1	In	Out	IBF B	OBFB	I/O
PC2	In	Out	STB B	ACK B	I/O
PC3	In	Out	INTR A	INTR A	INTR A
PC4	In	Out	STB A	I/O	STB A
PC5	In	Out	IBF A	I/O	IBF A
PC6	In	Out	I/O	ACK A	ACK A
PC7	In	Out	I/O	OBFA	OBFA

Mode 0 or Mode 1 Only

Special Mode Combination Considerations

There are several combinations of modes possible. For any combination, some or all of Port C lines are used for control or status. The remaining bits are either inputs or outputs as defined by a "Set Mode" command.

During a read of Port C, the state of all the Port C lines, except the ACK and STB lines, will be placed on the data bus. In place of the ACK and STB line states, flag status will appear on the data bus in the PC2, PC4, and PC6 bit positions as illustrated by Figure 25.

Through a "Write Port C" command, only the Port C pins programmed as outputs in a Mode 0 group can be written. No other pins can be affected by a "Write Port C" command, nor can the interrupt enable flags be accessed. To write to any Port C output programmed as an output in a Mode 1 group or to change an interrupt enable flag, the "Set/Reset Port C Bit" command must be used.

With a "Set/Reset Port C Bit" command, any Port C line programmed as an output (including IBF and OBFB) can be written, or an interrupt enable flag can be either set or reset. Port C lines programmed as inputs, including ACK and STB lines, associated with Port C fare not affected by a "Set/Reset Port C Bit" command. Writing to the corresponding Port C bit positions of the ACK and STB lines with the "Set/Reset Port C Bit" command will affect the Group A and Group B interrupt enable flags, as illustrated in Figure 25.

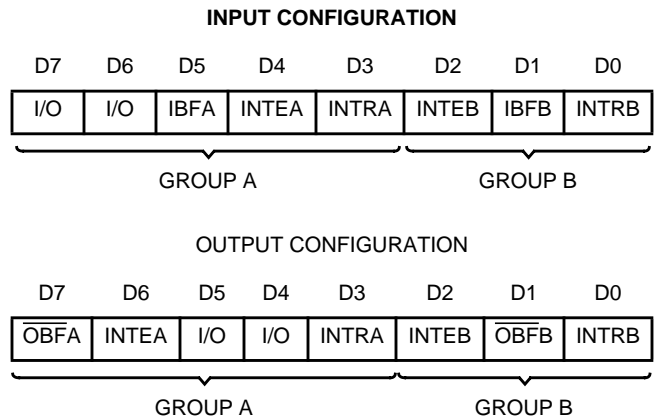
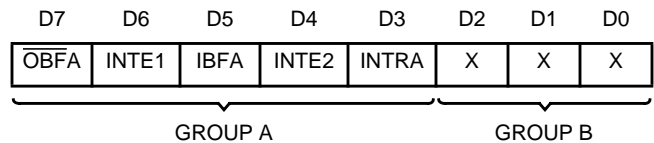

FIGURE 23. MODE 1 STATUS WORD FORMAT



NOTE: (Defined by Mode 0 or Mode 1 Selection)

FIGURE 24. MODE 2 STATUS WORD FORMAT

Current Drive Capability

Any output on Port A, B or C can sink or source 2.5mA. This feature allows the 82C55A to directly drive Darlington type drivers and high-voltage displays that require such sink or source current.

Reading Port C Status (Figures 23 and 24)

In Mode 0, Port C transfers data to or from the peripheral device. When the 82C55A is programmed to function in Modes 1 or 2, Port C generates or accepts “hand shaking” signals with the peripheral device. Reading the contents of Port C allows the programmer to test or verify the “status” of each peripheral device and change the program flow accordingly.

There is no special instruction to read the status information from Port C. A normal read operation of Port C is executed to perform this function.

INTERRUPT ENABLE FLAG*	POSITION	ALTERNATE PORT C PIN SIGNAL (MODE)
INTE B	PC2	\overline{ACKB} (Output Mode 1) or STBB (Input Mode 1)
INTE A2	PC4	\overline{STBA} (Input Mode 1 or Mode 2)
INTE A1	PC6	\overline{ACKA} (Output Mode 1 or Mode 2)

FIGURE 25. INTERRUPT ENABLE FLAGS IN MODES 1 AND 2

HS-82C55ARH

Metallization Topology

DIE DIMENSIONS:

3420 μm x 4350 μm x 485 μm \pm 25 μm

METALLIZATION:

Type: Al/Si

Thickness: 11k \AA \pm 2k \AA

GLASSIVATION:

Type: SiO₂

Thickness: 8k \AA \pm 1k \AA

WORST CASE CURRENT DENSITY:

7.7 x 10⁴ A/cm²

Metallization Mask Layout

HS-82C55ARH

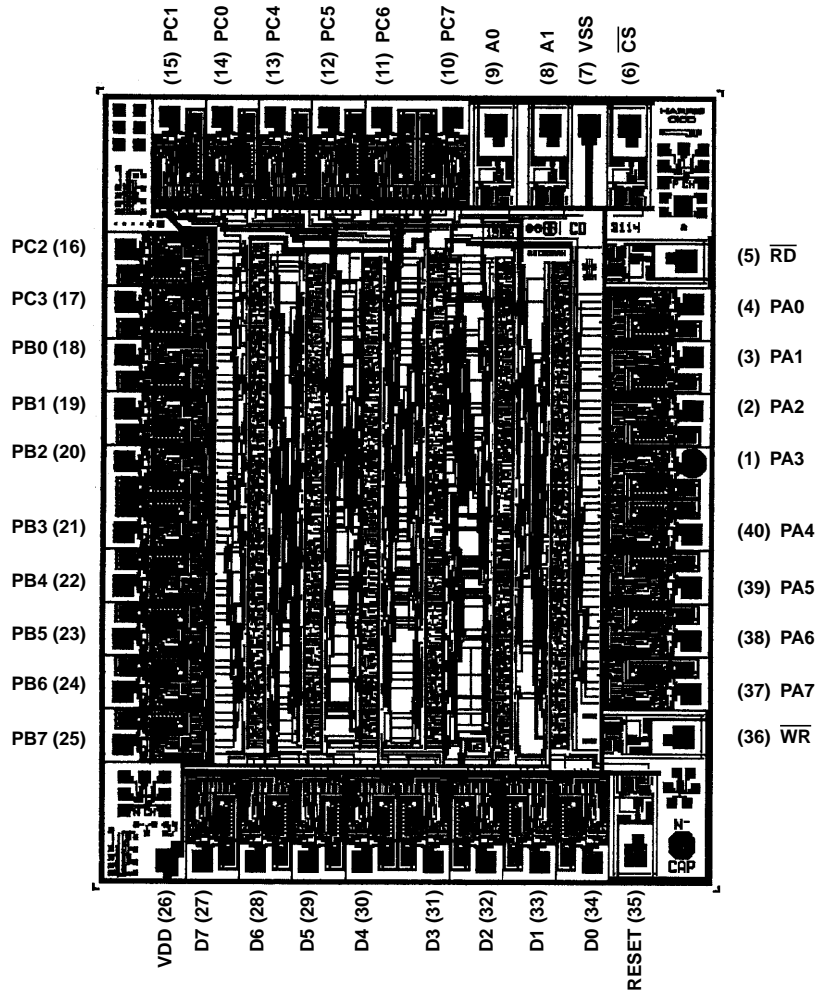

All Intersil semiconductor products are manufactured, assembled and tested under **ISO9000** quality systems certification.

Intersil products are sold by description only. Intersil Corporation reserves the right to make changes in circuit design and/or specifications at any time without notice. Accordingly, the reader is cautioned to verify that data sheets are current before placing orders. Information furnished by Intersil is believed to be accurate and reliable. However, no responsibility is assumed by Intersil or its subsidiaries for its use; nor for any infringements of patents or other rights of third parties which may result from its use. No license is granted by implication or otherwise under any patent or patent rights of Intersil or its subsidiaries.

For information regarding Intersil Corporation and its products, see web site <http://www.intersil.com>

Sales Office Headquarters

NORTH AMERICA

Intersil Corporation
P. O. Box 883, Mail Stop 53-204
Melbourne, FL 32902
TEL: (407) 724-7000
FAX: (407) 724-7240

EUROPE

Intersil SA
Mercure Center
100, Rue de la Fusee
1130 Brussels, Belgium
TEL: (32) 2.724.2111
FAX: (32) 2.724.22.05

ASIA

Intersil (Taiwan) Ltd.
Taiwan Limited
7F-6, No. 101 Fu Hsing North Road
Taipei, Taiwan
Republic of China
TEL: (886) 2 2716 9310
FAX: (886) 2 2715 3029

This datasheet has been downloaded from:

www.DatasheetCatalog.com

Datasheets for electronic components.



LittleDiode supplies new, hard to find or obsolete electronic components and semiconductors all over the world.

With over two million different components listed you are sure to find the part you need.

Feel free to visit us today at our online store:

LittleDiode.com

Looking forward to providing you with the best possible service.