



BC 171 • BC 172 • BC 173

NPN HIGH GAIN LOW NOISE

SILICON PLANAR EPITAXIAL TRANSISTOR

BC171
BC172
BC173

FEATURES

- High Breakdown Voltage $V_{CE0} \dots 50V$ (BC171)
- Available in Different Current Gain Groupings
- Low Noise N.F. $\dots 4dB_{max}$ @ $0.2mA$ (BC173)

APPLICATIONS

- Audio Amplifier Driver Stage
- Television Receiver Circuits
- Low Power General Purpose
- Low Noise Pre-Amplifier (BC173)

MECHANICAL OUTLINE

u - 135
(Lead Code A)
(TO-92 Variant)

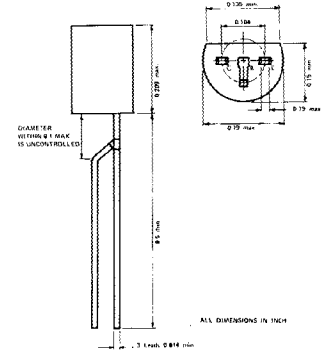

THERMAL CHARACTERISTICS

Thermal Resistance from Junction to Ambient $\theta (j-amb)$
Maximum Collector Junction Temperature
Storage Temperature Range
Soldering Temperature (10 sec. time limit)

$0.42^{\circ}C/mW$
 $150^{\circ}C$
 $-65^{\circ}C$ to $+150^{\circ}C$
 $260^{\circ}C$

ABSOLUTE MAXIMUM RATINGS

Continuous Power Dissipation @ $25^{\circ}C$ Ambient
Continuous Collector Current
Collector - Base Voltage
Collector - Emitter Voltage
Base - Emitter Voltage

| BC 171 | BC 172 | BC 173 |
|--------|--------|--------|
| 300 mW | 300 mW | 300 mW |
| 100 mA | 100 mA | 100 mA |
| 50 V | 25 V | 25 V |
| 45 V | 25 V | 25 V |
| 6 V | 5 V | 5 V |

ELECTRICAL CHARACTERISTICS @ $25^{\circ}C$ free air temperature :

| PARAMETER | SYMBOL | BC 171 | | BC 172 | | BC 173 | | UNIT | TEST CONDITIONS |
|--------------------------------------|---------------|--------|------|--------|------|--------|------|------|---|
| | | MIN. | MAX. | MIN. | MAX. | MIN. | MAX. | | |
| Collector-Base Cutoff Current | I_{CBO} | | 15 | | | | | nA | $V_{CB} = 45V$ |
| Collector-Base Cutoff Current | I_{CBO} | | | | 15 | | 15 | nA | $V_{CB} = 20V$ |
| Collector-Emitter Saturation Voltage | $V_{CE(sat)}$ | | 0.25 | 0.25 | | 0.25 | | V | $I_c = 10mA$ $I_B = 0.5mA$ |
| Collector-Emitter Saturation Voltage | $V_{CE(sat)}$ | | 0.6 | 0.6 | | 0.6 | | V | $I_c = 100mA$ $I_B = 5mA$ |
| Base-Emitter On Voltage | $V_{BE(sat)}$ | 0.55 | 0.7 | 0.55 | 0.7 | 0.55 | 0.7 | V | $V_{CE} = 5V$ $I_c = 2mA$ |
| Forward Current Transfer Ratio | h_{FE} | 110 | 450 | 110 | 800 | 110 | 800 | | $V_{CE} = 5V$ $I_c = 2mA$ |
| Small Signal Current Gain | h_{fe} | 1.5 | | 1.5 | | 1.5 | | | $f = 100MHz$ $I_c = 10mA$ $V_{CE} = 5V$ |
| Collector Output Capacitance | C_{ob} | | 6 | | 6 | | 6 | pF | $V_{CE} = 10V$ $f = 1MHz$ $I_E = 0$ |
| Noise Figure (Narrow Band) | N.F. | | 10 | | 10 | | 4 | dB | $V_{CE} = 5V$ $I_c = 0.2mA$ $R_g = 2K\Omega$ $f = 1KC$ $BW = 200Hz$ |
| Noise Figure (Wide Band) | N.F. | | | | | | 4 | dB | $V_{CE} = 5V$ $I_c = 0.2mA$ $R_g = 2K\Omega$ $f = 30Hz$ to $15KHz$ |

* D. C. CURRENT GAIN GROUPINGS

| TYPE | BC 171A | | BC 172B BC 173B | | BC 172C BC 173C | | BC 171A BC 172A BC 173A | | BC 171B BC 172B BC 173B | | BC 172C BC 173C | |
|------------------------------|---------|------|--------------------|------|--------------------|------|-------------------------------|------|-------------------------------|------|--------------------|------|
| | MIN. | MAX. | MIN. | MAX. | MIN. | MAX. | MIN. | MAX. | MIN. | MAX. | MIN. | MAX. |
| $V_{CE} = 5V$ $I_c = 0.01mA$ | | | 40 | | 40 | | 100 | | | | | |
| $V_{CE} = 5V$ $I_c = 2mA$ | | | | | | | 110 | 220 | 200 | 450 | 420 | 800 |

TYPICAL TWO PORT CHARACTERISTICS (h parameters)

| TYPE | BC 171A BC 172A BC 173A | BC 171B BC 172B BC 173B | BC 172C BC 173C | UNIT | TEST CONDITIONS |
|----------|-------------------------------|-------------------------------|--------------------|---------|--------------------------------------|
| h_{fe} | 180 | 300 | 600 | | $V_{CE} = 5V$ $I_c = 2mA$ $f = 1KHz$ |
| h_{ie} | 2.5 | 4 | 8 | Kohm | |
| h_{re} | 3×10^{-4} | 6×10^{-4} | 8×10^{-4} | | |
| h_{oe} | 20 | 26 | 50 | μS | |

12:74 REV 06

NPN SILICON PLANAR EPITAXIAL TRANSISTOR

TYPICAL ELECTRICAL CHARACTERISTICS BC 171 • BC 172 • BC 173

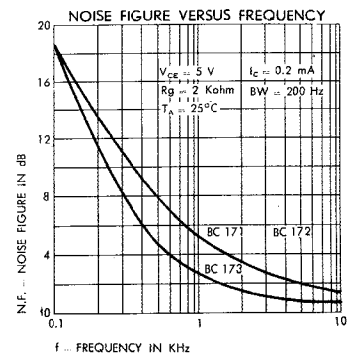
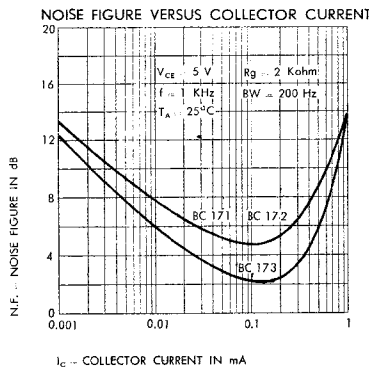
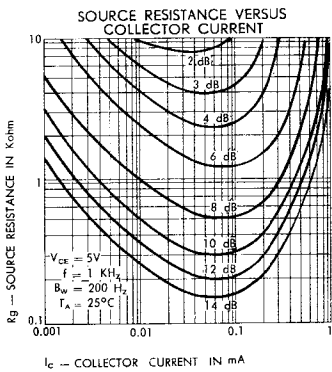
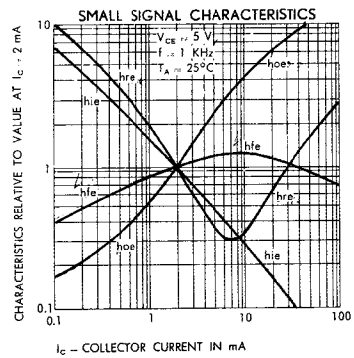
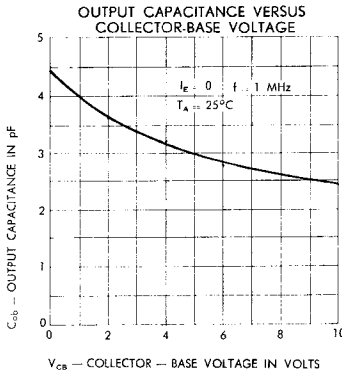
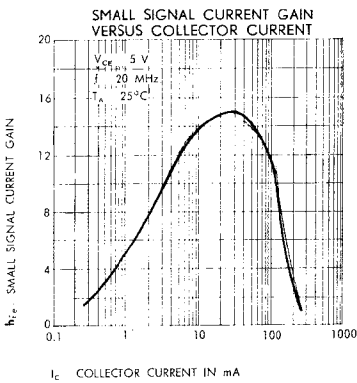
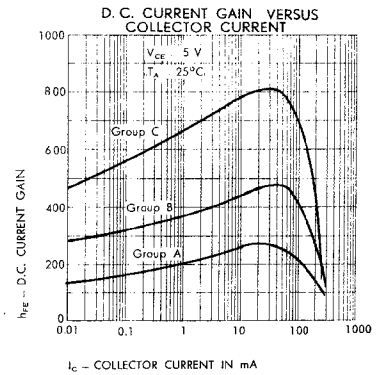
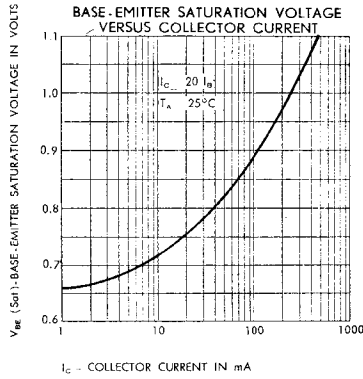
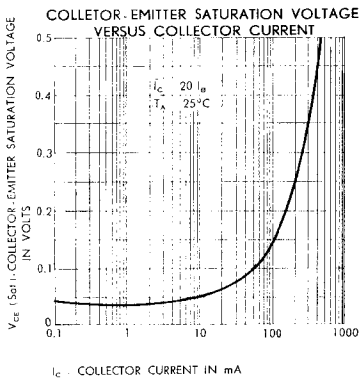
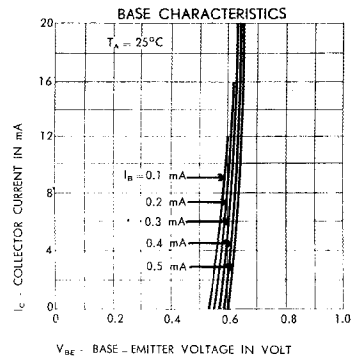
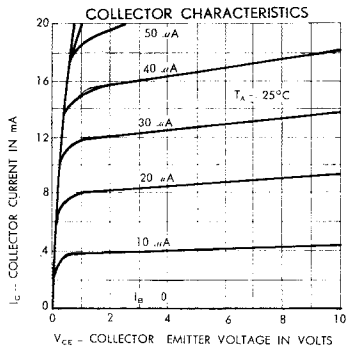
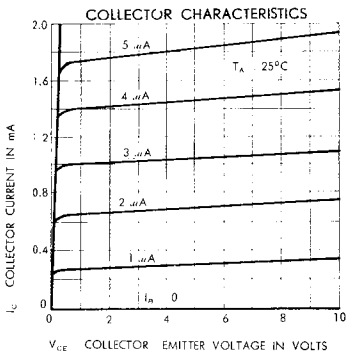



LittleDiode supplies new, hard to find or obsolete electronic components and semiconductors all over the world.

With over two million different components listed you are sure to find the part you need.

Feel free to visit us today at our online store:

LittleDiode.com

Looking forward to providing you with the best possible service.