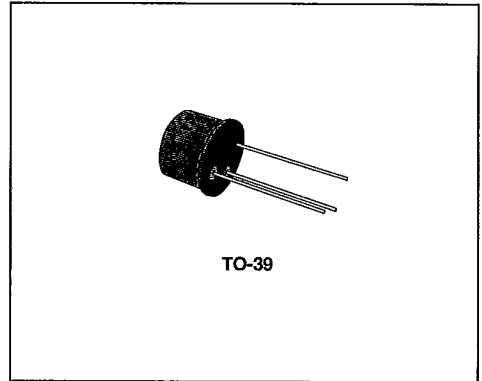
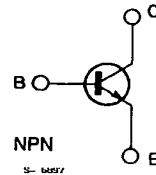

DESCRIPTION

The BSX45 and BSX46 are silicon planar epitaxial NPN transistors in Jedec TO-39 metal case, intended for use in medium power general industrial applications.

**INTERNAL SCHEMATIC DIAGRAM****ABSOLUTE MAXIMUM RATINGS**

Symbol	Parameter	BSX45	BSX46	Unit
V_{CES}	Collector-emitter Voltage ($V_{BE} = 0$)	80	100	V
V_{CEO}	Collector-emitter Voltage ($I_B = 0$)	40	60	V
V_{EBO}	Emitter-base Voltage ($I_C = 0$)	7		V
I_C	Collector Current	1		A
I_B	Base Current	0.2		A
P_{tot}	Total Power Dissipation at $T_{case} \leq 25^\circ\text{C}$	5		W
T_{stg}, T_J	Storage and Junction Temperature	- 65 to 200		$^\circ\text{C}$

THERMAL DATA

$R_{th\ j-case}$	Thermal Resistance Junction-case	Max	35	°C/W
$R_{th\ j-amb}$	Thermal Resistance Junction-ambient	Max	200	°C/W

ELECTRICAL CHARACTERISTICS ($T_{amb} = 25\text{ °C}$ unless otherwise specified)

Symbol	Parameter	Test Conditions	Min.	Typ.	Max.	Unit
I_{CES}	Collector Cutoff Current ($V_{BE} = 0$)	$V_{CE} = 60\text{ V}$ $V_{CE} = 60\text{ V}$ $T_{amb} = 150\text{ °C}$			30 10	nA μA
I_{CEX}	Collector Cutoff Current ($V_{BE} = -0.2\text{ V}$)	$V_{CE} = 60\text{ V}$ $T_{amb} = 100\text{ °C}$			50	μA
I_{EBO}	Emitter Cutoff Current ($I_C = 0$)	$V_{EB} = 5\text{ V}$			10	nA
$V_{(BR)CES}$	Collector-emitter Breakdown Voltage ($V_{BE} = 0$)	$I_C = 100\text{ }\mu\text{A}$ for BSX45 for BSX46	80 100			V V
$V_{(BR)CEO}^*$	Collector-emitter Breakdown Voltage ($I_B = 0$)	$I_C = 30\text{ mA}$ for BSX45 for BSX46	40 60			V V
$V_{(BR)EBO}$	Emitter-base Breakdown Voltage ($I_C = 0$)	$I_E = 100\text{ }\mu\text{A}$	7			V
$V_{CE(sat)}^*$	Collector-emitter Saturation Voltage	$I_C = 1\text{ A}$ $I_B = 0.1\text{ A}$		0.7	1	V
V_{BE}^*	Base-emitter Voltage	$I_C = 0.1\text{ A}$ $V_{CE} = 1\text{ V}$ $I_C = 0.5\text{ A}$ $V_{CE} = 1\text{ V}$ $I_C = 1\text{ A}$ $V_{CE} = 1\text{ V}$	0.75	1.3	1 1.5 2	V V V
h_{FE}^*	DC Current Gain	$I_C = 0.1\text{ mA}$ $V_{CE} = 1\text{ V}$ Gr. 6 Gr. 10 Gr. 16 $I_C = 100\text{ mA}$ $V_{CE} = 1\text{ V}$ Gr. 6 Gr. 10 Gr. 16 $I_C = 500\text{ mA}$ $V_{CE} = 1\text{ V}$ Gr. 6 Gr. 10 Gr. 16 $I_C = 1\text{ A}$ $V_{CE} = 1\text{ V}$ Gr. 6 Gr. 10 Gr. 16	10 15 25 40 63 100 15 25 35	28 40 90 63 100 160 25 40 60	100 160 250	
f_T	Transition Frequency	$I_C = 50\text{ mA}$ $V_{CE} = 10\text{ V}$ $f = 20\text{ MHz}$	50			MHz
C_{EBO}	Emitter-base Capacitance	$I_C = 0$ $V_{EB} = 0.5\text{ V}$ $f = 1\text{ MHz}$			80	pF

* Pulsed ; pulse duration = 300 μs , duty cycle = 1%.

** See test circuit.

ELECTRICAL CHARACTERISTICS (continued)

T-33-05

Symbol	Parameter	Test Conditions	Min.	Typ.	Max.	Unit
C_{CBO}	Collector-base Capacitance	$I_E = 0$ $f = 1 \text{ MHz}$ $V_{CB} = 10 \text{ V}$ for BSX45 for BSX46			25 20	pF
NF	Noise Figure	$I_C = 100 \mu\text{A}$ $R_g = 1 \text{ k}\Omega$ $V_{CE} = 10 \text{ V}$ $f = 1 \text{ kHz}$		3.5		dB
t_{on}^{**}	Turn-on Time	$I_C = 100 \text{ mA}$ $I_{B1} = 5 \text{ mA}$ $V_{CC} = 20 \text{ V}$			200	ns
t_{off}^{**}	Turn-off Time	$I_C = 100 \text{ mA}$ $I_{B1} = -I_{B2} = 5 \text{ mA}$ $V_{CC} = 20 \text{ V}$			850	ns

* Pulsed : pulse duration = 300μs, duty cycle = 1%.
** See test circuit.

Safe operating areas

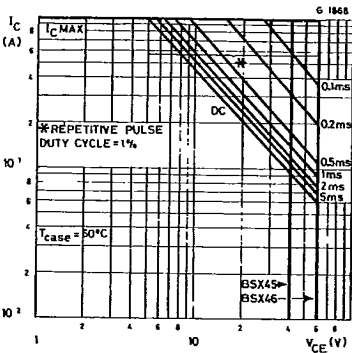

Collector-emitter Saturation Voltage.

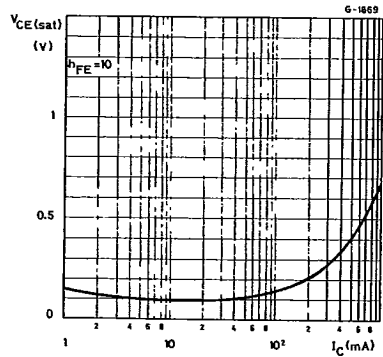

Base-emitter Saturation Voltage.

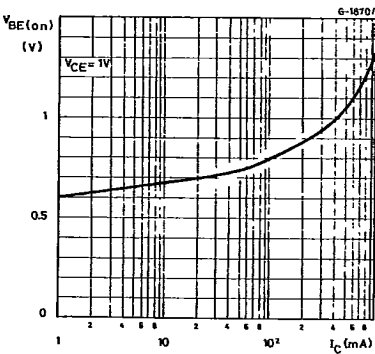

DC Current Gain.

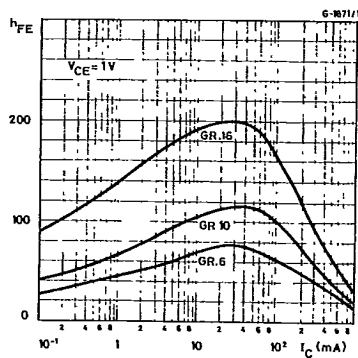

Transition Frequency.

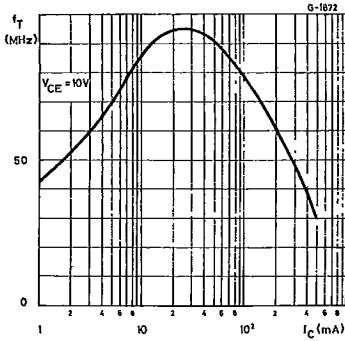

Test circuit for t_{on} , t_{off} .

