

MOTOROLA

SEMICONDUCTOR

TECHNICAL DATA

Advance Information

16-bit General Purpose Digital Signal Processor

DSP56166

Ceramic Quad Flat Pack (CQFP)

Available in a 112 pin, small footprint, surface mount package.

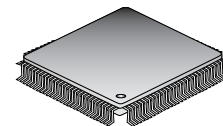

The DSP56166 is the second member of Motorola's DSP56100 family of HCMOS, low power, 16-bit general purpose Digital Signal Processors (DSP). Designed primarily for speech coding and digital communications, the DSP56166 has a built-in $\Sigma\Delta$ codec and phase locked loop (PLL). This MPU-style DSP also contains, memories, digital peripherals, and provides a cost effective, high performance solution to many DSP applications. On-Chip Emulation (OnCE™) circuitry provides convenient and inexpensive debug facilities normally available only through expensive external hardware. Development costs are reduced and in-field testing is greatly simplified by using the OnCE. The DSP56166 RAM based is an off the shelf part since there are no user programmable ROM's on-chip. The DSP56166 ROM based contains a 12K ROM (8Kx 16 program ROM and 4Kx16 data ROM).

The Central Processing Unit (CPU) consists of three execution units operating in parallel allowing up to six operations to occur in an instruction cycle. This parallelism greatly increases the effective processing speed of the DSP56166. The MPU-style programming model and instruction set allow straightforward generation of efficient, compact code. The basic architectures and development tools of the DSP56100 family, DSP56000 family, and DSP96002 are so similar that learning to design and program one greatly reduces the time needed to learn the others.

DSP56166ROM Feature List

DSP56100 Family Features

- | | |
|---|--|
| <ul style="list-style-type: none"> • Up to 30 Million Instructions per Second (MIPS) at 60 MHz.— 33.3 ns Instruction cycle • Single-cycle 16 x 16-bit parallel Multiply-Accumulate • 2 x 40-bit accumulators with extension byte • Fractional and integer arithmetic with support for multiprecision arithmetic • Highly parallel instruction set with unique DSP addressing modes • Nested hardware DO loops including infinite loops and DO zero loop • Two instruction LMS adaptive filter loop • Fast auto-return interrupts • Three external interrupt request pins | <ul style="list-style-type: none"> • Three 16-bit internal data and three 16-bit internal address buses • Individual programmable wait states on the external bus for program, data, and peripheral memory spaces • Off-chip memory-mapped peripheral space with programmable access time and separate peripheral enable pin • On-chip memory-mapped peripheral registers • Low Power Wait and Stop modes • On-Chip Emulation (OnCE) for unobtrusive, processor speed independent debugging • Operating frequency down to DC • 5V single power supply • Low power (HCMOS) |
|---|--|

DSP56166ROM On-chip Resources

- | | |
|---|---|
| <ul style="list-style-type: none"> • 4K x 16 on-chip data RAM • 4K x 16 on-chip data ROM • 256 x 16 on-chip program RAM • 8K x 16 on-chip program ROM • One external 16-bit address bus • One external 16-bit data bus • On-chip $\Sigma\Delta$ voice band codec (A/D-D/A) <ul style="list-style-type: none"> – Internal voltage reference (2/5 of positive power supply) | <ul style="list-style-type: none"> – No off-chip components required • 25 general purpose I/O pins • On-chip, programmable PLL • Byte-wide Host Interface with DMA support • Two independent reduced synchronous serial interfaces • One 16-bit timer • 112 pin quad flat pack packaging |
|---|---|

Operational Differences Of The ROM Based Part From The RAM Based Part

- | | |
|---|--|
| <ul style="list-style-type: none"> • XROM can only be accessed during a single read or the first read of a dual parallel read instruction (see note on page 2) | <ul style="list-style-type: none"> • Reset mode 1 vectors to P:\$0100 • PROM area P:\$2080 — P:\$20FF is reserved and should not be programmed or accessed by the user |
|---|--|

This document contains information on a new product. Specifications and information herein are subject to change without notice.



MOTOROLA

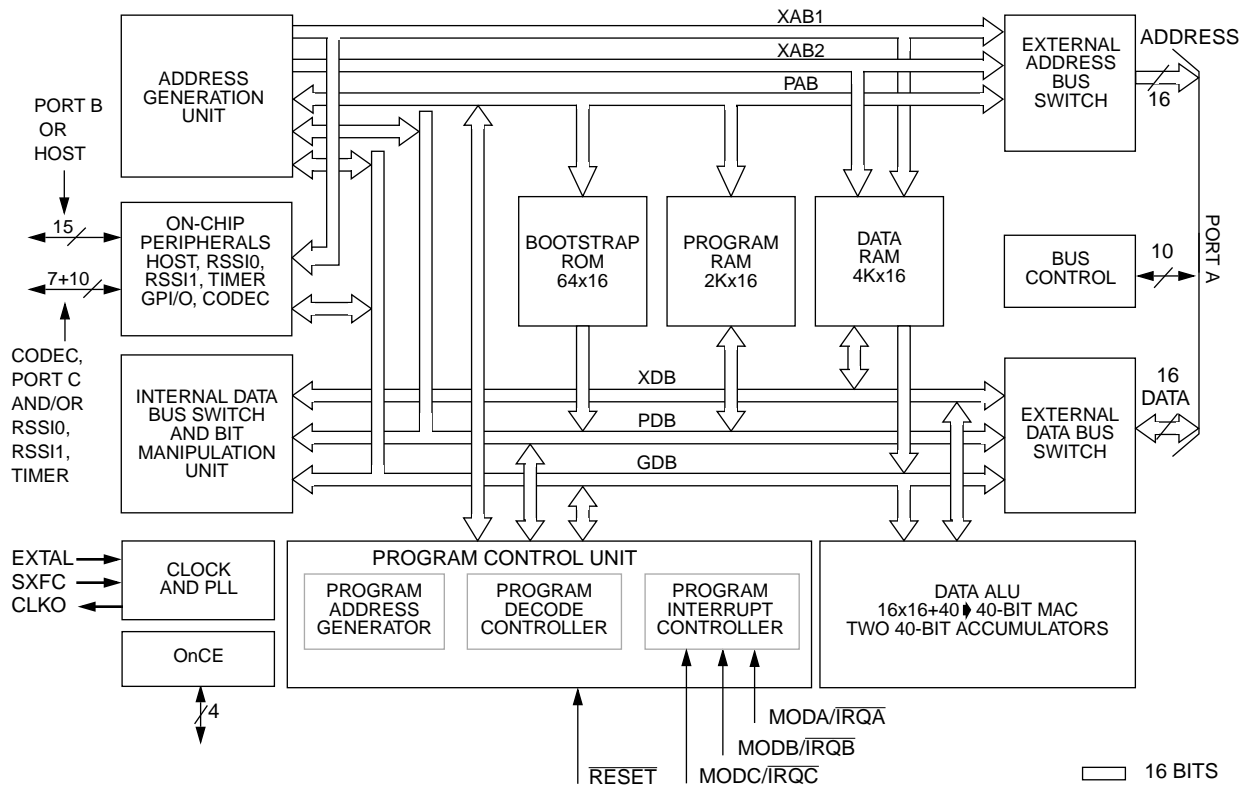

Figure 1 DSP56166 Block Diagram

In the USA:

For technical assistance call:
DSP Applications Helpline (512) 891-3230

For availability and literature call your local Motorola Sales Office or Authorized Distributor.

For free application software and information call the Dr. BuB electronic bulletin board:
9600/4800/2400/1200/300 baud
(512) 891-3771
(8 data bits, no parity, 1 stop)

In Europe, Japan and Asia Pacific

Contact your regional sales office or Motorola distributor.

Note: For the ROM part only (DSP56166ROM) — Since the on-chip XROM is only connected to the XAB1 address bus, the data located in this ROM is only accessible by the **first** read of a single read instruction or the **first** read of a dual parallel read instruction. Therefore, during development using the RAM based part, the data to be mapped in the on-chip XROM on the ROM based part **should not** be accessed with a **second** read during a dual parallel read instruction.

INTRODUCTION

This data sheet is intended to be used with the DSP56100 Family Manual and the DSP56166 User's Manual. The DSP56100 Family Manual provides a description of the components of the DSP5616 core processor that are common to all DSP56100 family processors and includes a detailed description of the basic DSP56100 family instruction set. The DSP56166 User's Manual provides a description of the memory and peripherals that are specific to the DSP56166. The DSP56166 Data Sheet provides electrical specifications and timings that are specific to the DSP56166.

The DSP56166 pinout is shown in Figure 3. The input and output signals on the chip are organized into the 13 functional groups shown in Table 1.

Table 1
Functional Group Pin Allocations

Functional Group	Number of Pins
Address and Data Buses	32
Bus Control	10
Interrupt and Mode Control	4
Clock and PLL	3
Host Interface or PIO	15
Timer Interface or PIO	2
RSSI Interfaces or PIO	8
On-chip CODEC	7
On-chip emulation (OnCE)	4
Power (Vdd)	9
Ground (Vss)	16
APower (Vdda)	1
AGround (Vssa)	1
Total	112

ADDRESS AND DATA BUS (32 PINS)

A0-A15 (Address Bus) — three state, active high outputs. A0-A15 change in t0 and specify the address for external program and data memory accesses. If there is no external bus activity, A0-A15 remain at their previous values. A0-A15 are three-stated during hardware reset, stop mode and when the DSP is not the bus master.

D0-D15 (Data Bus) — three state, active high, bidirectional input/outputs. Read data is sampled on the trailing edge of t2, while write data output is enabled by the leading edge of t2 and three-stated at the leading edge of t0. If there is no external bus activity, D0-D15 are three-stated. D0-D15 are also three-stated during hardware reset.

BUS CONTROL (10 PINS)

PS/ \overline{DS} (Program /Data Memory Select) — three state active low output. This output is asserted only when external data memory is referenced. PS/ \overline{DS} timing is the same for the A0-

A15 address lines. PS/ \overline{DS} is high for program memory access and is low for data memory access. If the external bus is not used during an instruction cycle (t0,t1,t2,t3), PS/ \overline{DS} goes high in t0. PS/ \overline{DS} is in the high impedance state during hardware reset, stop mode and when the DSP is not the bus master.

\overline{PEREN} (Peripheral Enable) — three state active low output. This output is asserted only when external peripheral space of the data memory is referenced (any address between X:\$FF00 and X:\$FF7F). \overline{PEREN} timing is the same as the A0-A15 address lines; it is asserted and deasserted during t0. \overline{PEREN} is high for any program memory access and for data memory access not in the space X:\$FF00 - X:\$FF7F. \overline{PEREN} is in the high impedance state during hardware reset, stop mode and when the DSP is not the bus master.

R/ \overline{W} (Read/Write) — three state, active low output. Timing is the same as for the address lines, providing an "early write" signal. R/ \overline{W} (which changes in t0) is high for a read access and is low for a write access. If the external bus is not used during an instruction cycle (t0,t1,t2,t3), R/ \overline{W} goes high in t0. R/ \overline{W} is three-stated during hardware reset, stop mode and when the DSP is not the bus master.

\overline{WR} (Write Enable) — three state, active low output. This output is asserted during external memory write cycles. When \overline{WR} is asserted in t1, the data bus pins D0-D15 become outputs and the DSP puts data on the bus during the leading edge of t2. When \overline{WR} is deasserted in t3, the external data has been latched inside the external device. When \overline{WR} is asserted, it qualifies the A0-A15 and PS/ \overline{DS} pins. \overline{WR} can be connected directly to the \overline{WE} pin of a static RAM. \overline{WR} is three-stated during hardware reset, stop mode and when the DSP is not the bus master.

\overline{RD} (Read Enable) — three state, active low output. This output is asserted during external memory read cycles. When \overline{RD} is asserted in late t0/early t1, the data bus pins D0-D15 become inputs and an external device is enabled onto the data bus. When \overline{RD} is deasserted in t3, the external data has been latched inside the DSP. When \overline{RD} is asserted, it qualifies the A0-A15 and PS/ \overline{DS} pins. \overline{RD} can be connected directly to the \overline{OE} pin of a static RAM or ROM. \overline{RD} is three-stated during hardware reset, stop mode and when the DSP is not the bus master.

\overline{BS} (Bus Strobe) — active low output. Asserted at the start of a bus cycle (during t0) and deasserted at the end of the bus cycle (during t2). This pin provides an "early bus start" signal which can be used as address latch and as an "early bus end" signal which can be used by an external bus controller. \overline{BS} is three-stated during hardware reset, stop mode and when the DSP is not the bus master.

\overline{TA} (Transfer Acknowledge) — active low input. If there is no external bus activity, the \overline{TA} input is ignored by the DSP. When there is external bus cycle activity, \overline{TA} can be used to insert wait states in the external bus cycle. \overline{TA} is sampled on the leading edge of the clock. Any number of wait states from 1 to infinity may be inserted by using \overline{TA} . If \overline{TA} is sampled high on the leading edge of the clock beginning the bus cycle, the bus cycle will end 2T after the \overline{TA} has been sampled low on a leading edge of the clock; if the Bus Control Register (BCR) value does not program more wait

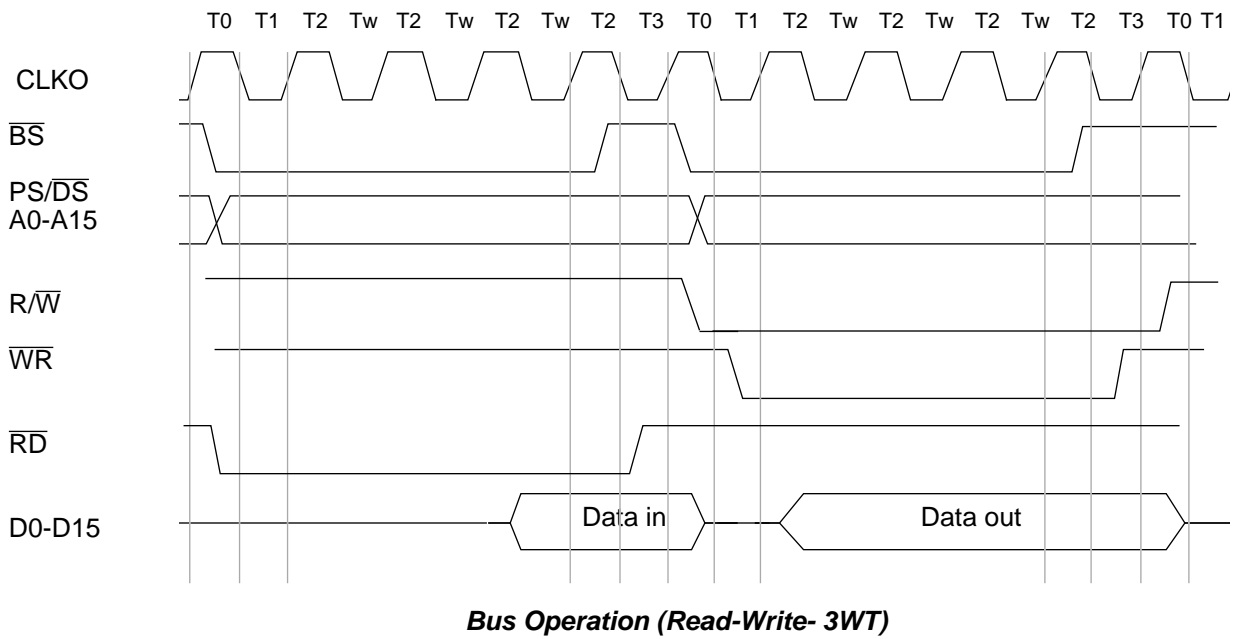
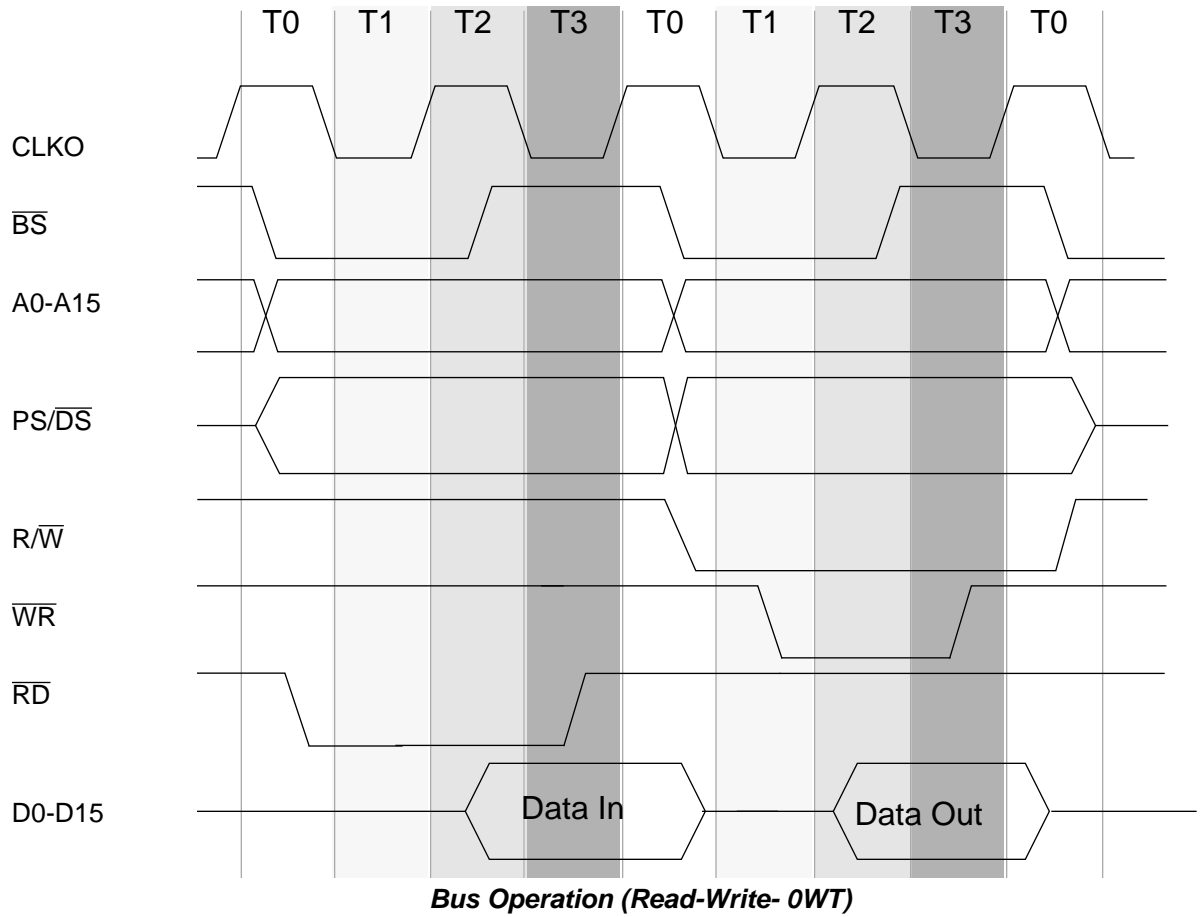

Figure 2 Bus Operation

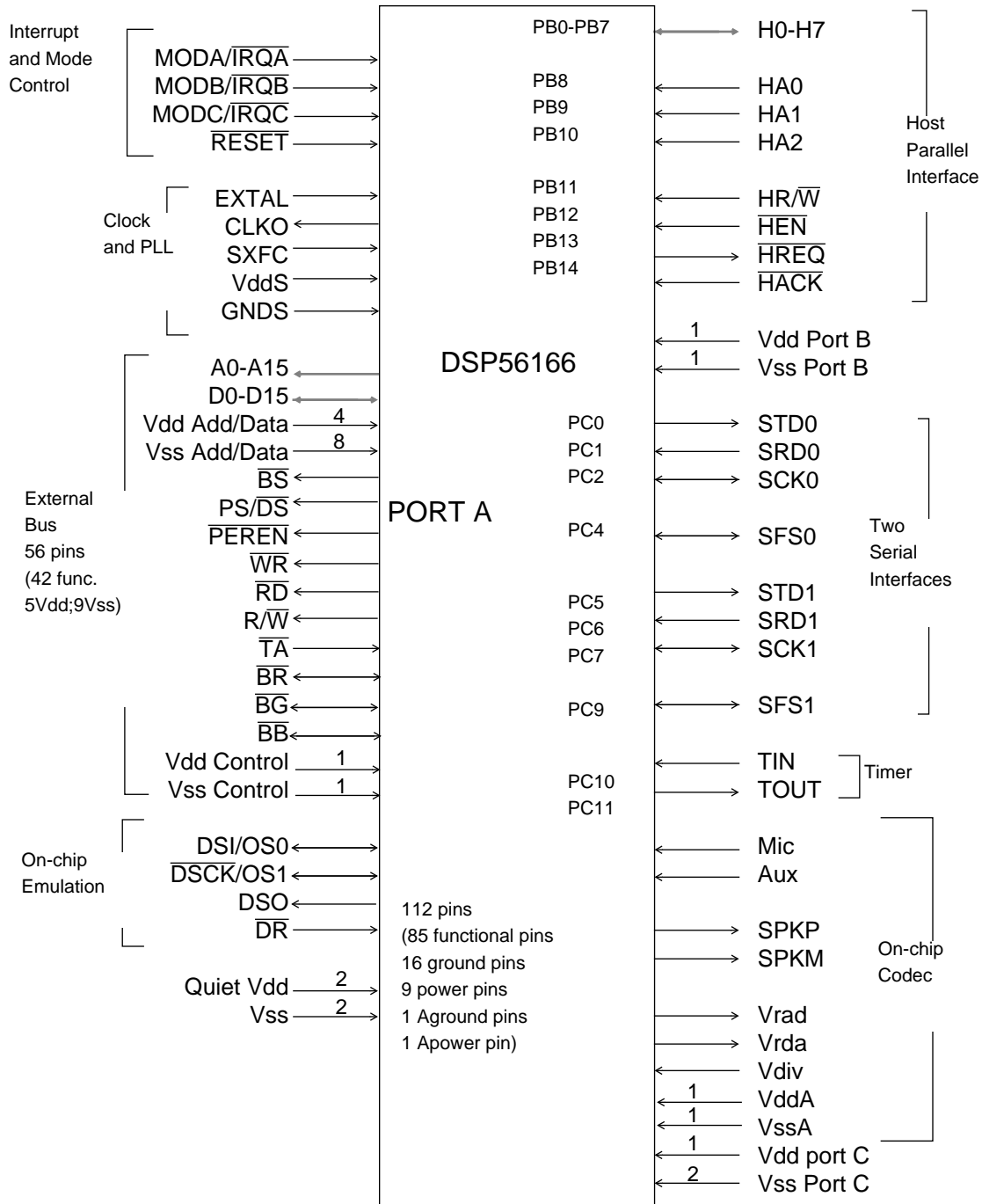

Figure 3 DSP56166 Pinout

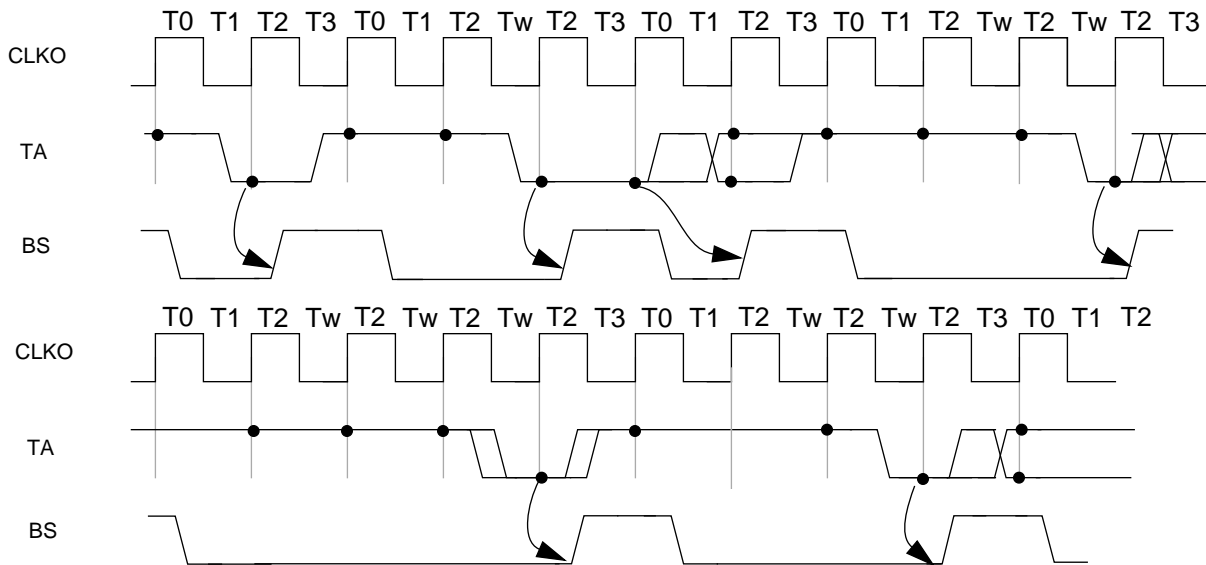

Figure 4 \overline{TA} Controlled Accesses

states. The number of wait states is determined by the \overline{TA} input or by the Bus Control Register (BCR), whichever is longer. \overline{TA} is still sampled during the leading edge of the clock when wait states are controlled by the BCR value. In that case, \overline{TA} will have to be sampled low during the leading edge of the last period of the bus cycle programmed by the BCR (2T) before the end of the bus cycle programmed by the BCR) in order not to add any wait states. \overline{TA} should always be deasserted during t3 to be sampled high by the leading edge of T0. If \overline{TA} is sampled low (asserted) at the leading edge of the t0 beginning the bus cycle, and if no wait states are specified in the BCR register, zero wait states will be inserted in the external bus cycle, regardless the status of \overline{TA} during the leading edge of T2.

\overline{BR} (Bus Request) — active low output when in master mode, active low input when in slave mode. This pin is an input (slave mode) after reset with \overline{MODC} pin low or when the bus arbitration mode bit in the OMR register is cleared. In this mode, the bus request \overline{BR} allows another device such as a processor or DMA controller to become the master of the DSP external data bus D0-D15 and external address bus A0-A15. The DSP asserts \overline{BG} a few T states after the \overline{BR} input is asserted. The DSP bus controller will release control of the external data bus D0-D15, address bus A0-A15 and bus control pins PS/DS, BS, RD, WR, R/W and \overline{PEREN} at the earliest time possible consistent with proper synchronization. These pins will then be placed in the high impedance state and the \overline{BB} pin will be deasserted. The DSP will continue executing instructions only if internal program and data memory resources are being accessed. If the DSP requests the external bus while \overline{BR} input pin is asserted, the DSP bus controller inserts wait states until the external bus becomes available (\overline{BR} and \overline{BB} deasserted). Note that interrupts are not serviced when a DSP instruction is waiting for the bus controller. Note also that \overline{BR} is prevented from interrupting the execution of a read/ modify/ write instruction.

This pin becomes an output (Master Mode) after reset with \overline{MODC} pin high or when the bus arbitration mode bit in the OMR register is set. In this mode, the DSP is not the external bus master and has to assert \overline{BR} to request the bus mastership. The DSP bus controller will insert wait states until \overline{BG} input is asserted and will then begin normal bus accesses after the rising of the clock which sampled \overline{BB} high. The \overline{BR} output signal will remain asserted until the DSP no longer needs the bus. In this mode, the Request Hold bit (RH) of the Bus Control Register (BCR) allows \overline{BR} to be asserted under software control.

During external accesses caused by an instruction executed out of external program memory, \overline{BR} remains asserted low for consecutive external memory accesses. In the master mode, \overline{BR} can also be used for non arbitration purpose: if \overline{BG} is always asserted, \overline{BR} is asserted in t0 of every external bus access. It can then be used as a chip select to turn an external memory device off and on between internal and external bus accesses. \overline{BR} timing is in that case similar to A0-A15, R/W and PS/DS; it is asserted and deasserted during t0.

\overline{BG} (Bus Grant) — active low input when in master mode, active low output when in slave mode. Output after power on reset if the slave mode is selected, this pin is asserted to acknowledge an external bus request. It indicates that the DSP will release control of the external address bus A0-A15, data bus D0-D15 and bus control pins when \overline{BB} is deasserted. The \overline{BG} output is asserted in response to a \overline{BR} input. When the \overline{BG} output is asserted, \overline{BB} will be deasserted and the external address bus A0-A15, data bus D0-D15 and bus control pins will be in the high impedance state at the end of the current instruction. \overline{BG} assertion may occur in the middle of an instruction which requires more than one external bus cycle for execution. Note that \overline{BG} assertion will not occur during indivisible read-modify-write instructions (BFSET, BFCLR, BFCHG). When \overline{BR} is deasserted, the \overline{BG} output is deasserted and the DSP

regains control of the external address bus, data bus, and bus control pins until the \overline{BB} pin is sampled high.

This pin becomes an input if the bus arbitration mode bit in the OMR register is set (Master Mode). It is asserted by an external processor when the DSP may become the bus master. The DSP can start normal external memory access after the \overline{BB} pin has been deasserted by the previous bus master. When \overline{BG} is deasserted, the DSP will release the bus as soon as the current transfer is completed. The state of \overline{BG} may be tested by testing the BS bit in the Bus Control Register.

\overline{BG} is ignored during hardware reset.

\overline{BB} (Bus Busy) — active low input when not bus master, active low output when bus master. This pin is asserted by the DSP when it becomes the bus master and it performs an external access. It is deasserted when the DSP releases bus mastership. \overline{BB} becomes an input when the DSP is no longer the bus master.

INTERRUPT AND MODE CONTROL (4 PINS)

$\overline{MODA}/\overline{IRQA}$ (Mode Select A/External Interrupt Request A) — This input has two functions - to select the initial chip operating mode and, after synchronization, to allow an external device to request a DSP interrupt. \overline{MODA} is read and internally latched in the DSP when the processor exits the reset state. \overline{MODA} and \overline{MODB} select the initial chip operating mode. Several clock cycles after leaving the reset state, the \overline{MODA} pin changes to the external interrupt request \overline{IRQA} . The chip operating mode can be changed by software after reset. The \overline{IRQA} input is a synchronized external interrupt request which indicates that an external device is requesting service. It may be programmed to be level sensitive or negative edge triggered. If level sensitive triggering is selected, an external pull up resistor is required for wired-OR operation. If the processor is in the stop standby state and \overline{IRQA} is asserted, the processor will exit the stop state.

$\overline{MODB}/\overline{IRQB}$ (Mode Select B/External Interrupt Request B) — This input has two functions - to select the initial chip operating mode and, after internal synchronization, to allow an external device to request a DSP interrupt. \overline{MODB} is read and internally latched in the DSP when the processor exits the reset state. \overline{MODA} and \overline{MODB} select the initial chip operating mode. Several clock cycles after leaving the reset state, the \overline{MODB} pin changes to the external interrupt request \overline{IRQB} . After reset, the chip operating mode can be changed by software. The \overline{IRQB} input is an external interrupt request which indicates that an external device is requesting service. It may be programmed to be level sensitive or negative edge triggered. If level sensitive triggering is selected, an external pull up resistor is required for wired-OR operation.

$\overline{MODC}/\overline{IRQC}$ (Mode Select C/External Interrupt Request C) — This input has two functions - to select the initial bus operating mode and after internal synchronization, to allow an external device to request a DSP interrupt. \overline{MODC} is read and internally latched in the DSP when the processor exits the RESET state. When tied high, the external bus is programmed in the master mode (\overline{BR} output and \overline{BG} input) and when tied low the bus is programmed in the slave mode (\overline{BR} input and \overline{BG} output). After RESET, the bus operating

mode can be changed by software writing the MC bit of the OMR register. Several clock cycles after leaving the RESET state, the \overline{MODC} pin changes to the external interrupt request \overline{IRQC} . The \overline{IRQC} input is an external interrupt request which indicates that an external device is requesting service. It may be programmed to be level sensitive or negative edge triggered. If level sensitive triggering is selected, an external pull up resistor is required for wired-OR operation.

\overline{RESET} (Reset) — This input is a direct hardware reset of the processor. When \overline{RESET} is asserted, the DSP is initialized and placed in the reset state. A Schmitt trigger input is used for noise immunity. When the reset pin is deasserted, the initial chip operating mode is latched from the \overline{MODA} and \overline{MODB} pins. The internal reset signal is deasserted synchronously with the internal clocks.

POWER, GROUND, AND CLOCK (28 PINS)

VDD (8) (Power) — power pins.

VSS (15) (Ground) — ground pins.

$VDDS$ (Synthesizer Power) — This pin supplies a quiet power source to the PLL to provide greater frequency stability.

$GNDS$ (Synthesizer Ground) — This pin supplies a quiet ground source to the PLL to provide greater frequency stability.

$VDDA$ (Power Supply input) — This pin is the positive analog supply input. It should be connected to VCC when the codec is not used.

$VSSA$ (Analog Ground) — This pin is the analog ground return. It should be connected to VSS when the codec is not used.

$EXTAL$ (External Clock/Crystal Input) — This input should be connected to an external clock or to an external oscillator. A sine wave with a minimum swing of 1Vpp can be applied to this pin. After being squared, the input frequency can be used as the DSP core internal clock. In that case, it is divided by two to produce a four phase instruction cycle clock, the minimum instruction time being two input clock periods. This input frequency is also used, after division, as input clock for the on-chip codec and the on-chip phase locked loop (PLL).

$CLKO$ (Clock Output) — This pin outputs a buffered clock signal. By programming two bits (CS1-CS0) inside the PLL Control Register (PLCR), the user can select between outputting a squared version of the signal applied to $EXTAL$, a squared version of the signal applied to $EXTAL$ divided by 2, and a delayed version of the DSP core master clock. The clock frequency on this pin can be disabled by setting the Clockout Disable bit (CD; bit 7) of the Operating Mode Register (OMR). In this case, the pin is driven low and can be left floating.

$SXFC$ (External Filter Capacitor) — This pin is used to add an external capacitor to the PLL filter circuit. A low leakage capacitor should be connected between $SXFC$ and $VDDS$; it should be located very close to those pins.

HOST INTERFACE (15 PINS)

H0-H7 (Host Data Bus) — This bidirectional data bus is used to transfer data between the host processor and the DSP. This bus is an input unless enabled by a host processor read. H0-H7 may be programmed as general purpose parallel I/O pins called PB0-PB7 when the Host Interface (HI) is not being used.

HA0-2 (Host Address 0-2) — These inputs provide the address selection for each HI register and should be stable when \overline{HEN} is asserted. HA0-HA2 may be programmed as general purpose parallel I/O pins called PB8-PB10 when the HI is not being used.

HR \overline{W} (Host Read/Write) — This input selects the direction of data transfer for each host processor access. If HR \overline{W} is high and \overline{HEN} is asserted, H0-H7 are outputs and DSP data is transferred to the host processor. If HR \overline{W} is low and \overline{HEN} is asserted, H0-H7 are inputs and host data is transferred to the DSP. HR \overline{W} should be stable when \overline{HEN} is asserted. HR \overline{W} may be programmed as a general purpose I/O pin called PB11 when the HI is not being used.

HEN (Host Enable) — This input enables a data transfer on the host data bus. When \overline{HEN} is asserted and HR \overline{W} is high, H0-H7 becomes an output and DSP data may be latched by the host processor. When \overline{HEN} is asserted and HR \overline{W} is low, H0-H7 is an input and host data is latched inside the DSP when \overline{HEN} is deasserted. Normally a chip select signal derived from host address decoding and an enable clock is connected to the Host Enable. \overline{HEN} may be programmed as a general purpose I/O pin called PB12 when the HI is not being used.

HREQ (Host Request) — This open-drain output signal is used by the HI to request service from the host processor. HREQ may be connected to an interrupt request pin of a host processor, a transfer request of a DMA controller, or a control input of external circuitry. HREQ is asserted when an enabled request occurs in the HI. HREQ is deasserted when the enabled request is cleared or masked, DMA H \overline{ACK} is asserted, or the DSP is reset. HREQ may be programmed as a general purpose I/O pin (not open-drain) called PB13 when the HI is not being used.

HACK (Host Acknowledge) — This input has two functions - (1) to provide a Host Acknowledge signal for DMA transfers or (2) to control handshaking and to provide a Host Interrupt Acknowledge compatible with MC68000 family processors. If programmed as a Host Acknowledge signal, H \overline{ACK} may be used as a data strobe for HI DMA data transfers. If programmed as an MC68000 Host Interrupt Acknowledge, H \overline{ACK} is used to enable the HI Interrupt Vector Register (IVR) onto the Host Data Bus H0-H7 if the Host Request HREQ output is asserted. In this case, all other HI control pins are ignored and the HI state is not affected. H \overline{ACK} may be programmed as a general purpose I/O pin called PB14 when the HI is not being used.

16-BIT TIMER (2 PINS)

TIN (Timer Input) — This input receives external pulses to be counted by the on-chip 16-bit timer when external clocking is selected. The pulses are internally synchronized to the DSP core internal clock. TIN may be programmed as

a general purpose I/O pin called PC10 when the external event function is not being used.

TOUT (Timer Output) — This output generates pulses or toggles on a timer overflow event or a compare event. TOUT may be programmed as a general purpose I/O pin called PC11 when disabled by the timer out enable bits (TO2-TO0).

SYNCHRONOUS SERIAL INTERFACES (RSSI0 AND RSSI1) (8 PINS)

STD0/PC0 (RSSI0 Transmit Data) — This output pin transmits serial data from the RSSI0 Transmit Shift Register. STD0 may be programmed as a general purpose I/O pin called PC0 when the RSSI0 STD0 function is not being used.

SRD0/PC1 (RSSI0 Receive Data) — This input pin receives serial data and transfers the data to the RSSI0 Receive Shift Register. SRD0 may be programmed as a general purpose I/O pin called PC1 when the RSSI0 SRD0 function is not being used.

SCK0/PC2 (RSSI0 Serial Clock) — This bidirectional pin provides the serial bit rate clock for the RSSI0 interface. The clock signal can be continuous or gated and is used by both the transmitter and receiver. SCK0 may be programmed as a general purpose I/O pin called PC2 when the RSSI0 interface is not being used.

SFS0/PC4 (Serial Frame Sync 0) — This bidirectional pin is used by the RSSI0 serial interface as frame sync I/O or flag I/O. The SFS0 is used by both the transmitter and receiver to synchronize the data transfer of the data. It can be input or output. SFS0 may be programmed as a general purpose I/O pin called PC4 when the RSSI0 is not using this pin.

STD1/PC5 (RSSI1 Transmit Data) — This output pin transmits serial data from the RSSI1 Transmit Shift Register. STD1 may be programmed as a general purpose I/O pin called PC5 when the RSSI1 STD1 function is not being used.

SRD1/PC6 (RSSI1 Receive Data) — This input pin receives serial data and transfers the data to the RSSI1 Receive Shift Register. SRD1 may be programmed as a general purpose I/O pin called PC6 when the RSSI1 SRD function is not being used.

SCK1/PC7 (RSSI1 Serial Clock) — This bidirectional pin provides the serial bit rate clock for the RSSI1 interface. The clock signal can be continuous or gated and is used by both the transmitter and receiver. SCK1 may be programmed as a general purpose I/O pin called PC7 when the RSSI1 interface is not being used.

SFS1/PC9 (Serial Frame Sync 1) — This bidirectional pin is used by the RSSI1 serial interface as frame sync I/O or flag I/O. The SFS1 is used by both the transmitter and receiver to synchronize the data transfer of the data. It can be input or output. SFS1 may be programmed as a general purpose I/O pin called PC9 when the RSSI1 is not using this pin.

ON-CHIP EMULATION (4 PINS)

DSI/OS0 (Debug Serial Input/Chip Status 0) — The DSI/OS0 pin, when an input, is the pin through which serial data or commands are provided to the OnCE controller. The data received on the DSI pin will be recognized only when the DSP has entered the debug mode of operation. Data must have valid TTL logic levels before the serial clock falling edge. Data is always shifted into the OnCE serial port most significant bit (MSB) first. When the DSP is not in the debug mode, the DSI/OS0 pin is an output and it provides information about the chip status. It is used in conjunction with the OS1 pin.

DSCK/OS1 (Debug Serial Clock/Chip Status 1) — The DSCK/OS1 pin, when an input, is the pin through which the serial clock is supplied to the OnCE. The serial clock provides pulses required to shift data into and out of the OnCE serial port. Data is clocked into the OnCE on the falling edge and is clocked out of the OnCE serial port on the rising edge. When the DSP is not in the debug mode, the DSCK/OS1 pin is an output and it provides information about the chip status. It is used in conjunction with the OS0 pin.

DSO (Debug Serial Output) — The debug serial output provides the data contained in one of the OnCE controller registers as specified by the last command received from the command controller. When idle, this pin is high. When the requested data is available, the DSO line will be asserted (negative true logic) for nine T cycles (more than two instruction cycles) to indicate that the serial shift register is ready to receive clocks in order to deliver the data. When the chip enters the debug mode due to an external debug request (DR), an internal software debug request (DEBUG), a hardware breakpoint occurrence or a trace/step occurrence, this line will be asserted for eight T cycles to indicate that the chip has entered the debug mode and is waiting for commands. Data is always shifted out the OnCE serial port most significant bit (MSB) first.

DR (Debug Request Input) — The debug request input provides a means of entering the debug mode of operation. This pin when asserted (negative true logic) will cause the DSP to finish the current instruction being executed, enter the debug mode, and wait for commands to be entered from the debug serial input line.

ON-CHIP CODEC (7 PINS)

AUX (Auxiliary input) — This pin is selected as the analog input to the A/D converter when the INS bit is set in the codec control register COCR. This pin should be left floating when the codec is not used.

BIAS (Bias current pin) — This input is used to determine the bias current for the analog circuitry. Connecting a resistor between BIAS and VGND will program the current bias generator. This pin should be left floating when the codec is not used.

MIC (Microphone input) — This pin is selected as the analog input to the A/D converter when the INS bit is cleared in the codec control register COCR. This pin should be left floating when the codec is not used.

SPKP (Speaker Positive Output) — This pin is the positive analog output from the on-chip D/A converter. This pin should be left floating when the codec is not used.

SPKM (Speaker Negative Output) — This pin is the negative analog output from the on-chip D/A converter. This pin should be left floating when the codec is not used.

VRAD (Voltage Reference Output for the A/D) — This pin is the output of the op-amp buffer in the reference voltage generator for the A/D section. It has a value of (2/5) VDDA. This voltage is used for analog ground internal to the block. This pin should always be connected to the Ground through two capacitors, even when the codec is not used.

VRDA (Voltage Reference Output for the D/A) — This pin is the output of the op-amp buffer in the reference voltage generator for the D/A section. It has a value of (2/5) VDDA. This voltage is used for analog ground internal to the block. This pin should always be connected to the Ground through two capacitors, even when the codec is not used.

VDIV (Voltage Division Output) — This pin is the input to the op-amp buffer in the reference voltage generator. It is connected to a resistor divider network located within the codec block which provides a voltage equal to (2/5)VDDA. This pin should be connected to the ground via a capacitor when the codec is used and should be left floating when the codec is not used.

PINOUT AND PACKAGE INFORMATION

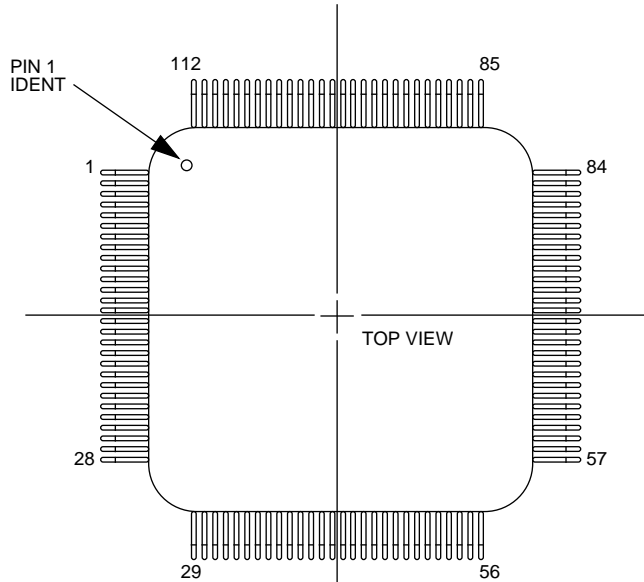

MOTOROLA DSP56166 112 CQFP PACKAGE PIN-OUT

PIN #	FUNCTION	PIN #	FUNCTION	PIN #	FUNCTION	PIN #	FUNCTION
1	GND4	29	MIC	57	H6/PB6	85	MODB
2	D2	30	AUX	58	H5/PB5	86	MODC
3	D3	31	VRAD	59	VDD6	87	A0
4	VDD3	32	\overline{BG}	60	H2/PB2	88	A1
5	D4	33	QVDD0	61	H3/PB3	89	GND0
6	D5	34	\overline{BR}	62	H4/PB4	90	A2
7	GND5	35	\overline{BB}	63	SRD1/PC6	91	A3
8	D6	36	VDD5	64	STD1/PC5	92	VDD1
9	D7	37	\overline{WR}	65	H1/PB1	93	A4
10	D8	38	GND8	66	H0/PB0	94	A5
11	D9	39	\overline{RD}	67	\overline{HREQ} /PB13	95	GND1
12	GND6	40	$\overline{PS/DS}$	68	\overline{HACK} /PB14	96	QVDD1
13	D10	41	\overline{BS}	69	\overline{HEN} /PB12	97	A6
14	D11	42	$\overline{R/W}$	70	\overline{HRW} /PB11	98	A7
15	VDD4	43	DSO	71	HA2/PB10	99	A8
16	D12	44	$\overline{DSCK/OS1}$	72	HA1/PB9	100	A9
17	D13	45	DSI/OS0	73	GND10	101	GND2
18	GND7	46	CLKO	74	HA0/PB8	102	A10
19	D14	47	QGND0	75	TOUT/PC11	103	VDD2
20	D15	48	GND5	76	VDD7	104	QGND1
21	\overline{TA}	49	XFC	77	TIN/PC10	105	A11
22	\overline{DR}	50	VDDS	78	SFS0/PC4	106	A12
23	VDDA	51	EXTAL	79	GND11	107	A13
24	SPKP	52	SFS1/PC9	80	SCK0/PC2	108	GND3
25	SPKM	53	GND9	81	SRD0/PC1	109	A14
26	GNDA	54	\overline{PEREN}	82	STD0/PC0	110	A15
27	VDIV	55	SCK1/PC7	83	\overline{RESET}	111	D0
28	VRDA	56	H7/PB7	84	MODA	112	D1

	Internal	A0-A15	D0-D15	Bus control	Port B, Once, PortC	Codec
Vcc	QVDD0-1	VDD1-2	VDD3-4	VDD5	VDD6,VDD7	VDDA
GND	QGND0-1	GND0-3	GND4-7	GND8	GND9,GND10, GND11	GNDA

The preliminary DC/AC electrical specifications are generated from design simulations. These specifications may not be fully tested or guaranteed at this early stage of the product life cycle. Finalized specifications will be published after complete characterization and device qualifications have been completed.

APPENDIX E ELECTRICAL CHARACTERISTICS AND TIMING

The DSP56166 is fabricated in high density HCMOS with TTL compatible inputs and CMOS compatible outputs.

Maximum Electrical Ratings (VSS = 0 Vdc)

Rating	Symbol	Value	Unit
Supply Voltage	V _{dd}	-0.3 to +7.0	V
All Input Voltages	V _{in}	VSS- 0.5 to V _{dd} + 0.5	V
Current Drain per Pin excluding V _{dd} and VSS	I	10	mA
Storage Temperature	T _{stg}	-55 to +150	°C

Operating Conditions

Marking	Speed	Supply Voltage VDD(V)		Junction Temperature T _j (°C)	
		Min	Max	Min	Max
FE60	60 MHz	4.5	5.5	-40	125

Thermal Characteristics — CQFP Package

Characteristics Thermal Resistance — Ceramic	Symbol	Value	Rating
Junction to Ambient	Θ_{JA}	40	°C/W
Junction to Case (estimated)	Θ_{JC}	7	°C/W

Thermal Characteristics — PQFP Package

Characteristics Thermal Resistance — Plastic	Symbol	Value	Rating
Junction to Ambient	Θ_{JA}	35	°C/W
Junction to Case (estimated)	Θ_{JC}	13	°C/W

This device contains protective circuitry against damage due to high static voltage or electrical fields; however, it is advised that normal precautions be taken to avoid application of any voltages higher than maximum rated voltages to this high-impedance circuit. Reliability of operation is enhanced if unused inputs are tied to an appropriate logic voltage level (e.g., either Vss or Vdd).

Power Considerations

The average chip junction temperature, T_J , in °C can be obtained from:

$$T_J = T_A + (P_D * \Theta_{JA}) \quad (1)$$

Where:

T_A = Ambient Temperature, °C

Θ_{JA} = Package Thermal Resistance, Junction-to-Ambient, °C/W

$P_D = P_{INT} + P_{I/O}$

$P_{INT} = I_{CC} * V_{DD}$, Watts — Chip Internal Power

$P_{I/O}$ = Power Dissipation on Input and Output Pins — User Determined

For most applications $P_{I/O} < P_{INT}$ and can be neglected. An appropriate relationship between P_D and T_J (if $P_{I/O}$ is neglected) is:

$$P_D = K / (T_J + 273^\circ \text{C}) \quad (2)$$

Solving equations (1) and (2) for K gives:

$$K = P_D * (T_A + 273^\circ \text{C}) + \Theta_{JA} * P_D \quad (3)$$

Where K is a constant pertaining to the particular part. K can be determined from equation (2) by measuring P_D (at equilibrium) for a known T_A . Using this value of K, the values of P_D and T_J can be obtained by solving equations (1) and (2) iteratively for any value of T_A . The total thermal resistance of a package (Θ_{JA}) can be separated into two components, Θ_{JA} and C_A , representing the barrier to heat flow from the semiconductor junction to the package (case) surface (Θ_{JC}) and from the case to the outside ambient (C_A). These terms are related by the equation:

$$\Theta_{JA} = \Theta_{JC} + C_A \quad (4)$$

Θ_{JC} is device related and cannot be influenced by the user. However, C_A is user dependent and can be minimized by such thermal management techniques as heat sinks, ambient air cooling, and thermal convection. Thus, good thermal management on the part of the user can significantly reduce C_A so that Θ_{JA} approximately equals Θ_{JC} . Substitution of Θ_{JC} for Θ_{JA} in equation (1) will result in a lower semiconductor junction temperature. Values for thermal resistance presented in this document, unless estimated, were derived using the procedure described in Motorola Reliability Report 7843, "Thermal Resistance Measurement Method for MC68XX Microcomponent Devices", and are provided for design purposes only. Thermal measurements are complex and dependent on procedure and setup. User—derived values for thermal resistance may differ.

Layout Practices

Each DSP56166 Vdd pin should be provided with a low-impedance path to + 5 volts. Each DSP56166 Vss pin should likewise be provided with a low-impedance path to ground. The power supply pins drive six distinct groups of logic on chip. They are:

Power and Ground Connections for CQFP and PQFP

Vdd	Vss	Function
33,96	47,104	Internal Logic supply pins
92,103	89,95,101,108	Address bus output buffer supply pins
4,15	1,7,12,18	Data bus output buffer supply pins
36	38	Bus control buffer supply pins
59,76	53,73,79	OnCE, Port B and C output buffer supply pins
23	26	Codec analog supply pins

Power and Ground Connections

The VDD power supply should be bypassed to ground using at least six 0.01-0.1 uF bypass capacitors located either underneath the chip's socket or as close as possible to the four sides of the package. The capacitor leads and associated printed circuit traces connecting to chip Vdd and Vss should be kept to less than 1/2" per capacitor lead. The use of at least a four layer board is recommended, employing two inner layers as Vdd and Vss planes. All output pins on the DSP56166 have fast rise and fall times. Printed circuit (PC) trace interconnection length should be minimized in order to minimize undershoot and reflections caused by these fast output switching times. This recommendation particularly applies to the address and data buses as well as the PS/DS, BS, RD, WR, R/W, PEREN, IRQA, IRQB, and HEN pins. Maximum PC trace lengths on the order of 6" are recommended. Capacitance calculations should consider all device loads as well as parasitic capacitances due to the PC traces. Attention to proper PCB layout and bypassing becomes especially critical in systems with higher capacitive loads because these loads create higher transient currents in the Vdd and Vss circuits.

The analog power for the VDDA pin and the analog ground for the VSSA pin should be separated from the digital VDD and ground planes. The analog power and ground planes should only be tied to the digital power and ground planes at one point where current enters and exits only at this point.

The analog VDD and ground planes should not have digital signal running over them if possible. The analog VDD and ground pins should be decoupled as close to the DSP as possible.

Clocks signals should not be run across many signals and should be kept away from analog power and ground signals as well as any analog signals.

Refer to Analog I/O Figure 1. for more details.

Power Dissipation

(Vdd = 5.0 Vdc +/- 10%, TJ = -40 to +125 °C, CL = 50 pF + 1 TTL Load).

The DC electrical characteristics of this device are shown below.

Conditions	Symbol	Typical(5V)	Unit
		60 MHz	
Digital Vdd with Codec & PLL disabled	IDD	100	mA
	PD	500	mW
Digital Vdd WAIT Mode with CODEC & PLL disabled	IDD	11	mA
	PD	55	mW

Conditions	Symbol	Typical (5V)	Unit
STOP Mode with PLL and CLKO disabled	IDD	400	μA
	PD	2	mW
Digital current drawn by the PLL when active	IDD	2	mA
	PD	10	mW
Analog Vdd with CODEC enabled	IDDA	10	mA
	PDA	20	mW
Analog Vdd with CODEC disabled	IDDA	75	μA
	PDA	375	μW

In order to minimize the power dissipation, all unused digital inputs pins should be tied inactive to VDD or Vss and all unused I/O pins should be tied inactive through a 10KΩ resistor to VDD or Vss. All port A input pins and bydirectional pins must have a valid state at all time when port A is released in order to minimize power; those pins must then be pulled up or down or driven by another device.

When the codec is not used, VDDA should be connected to VDD and VssA to Vss, and all codec pins should be left floating except Vref which should still be decoupled.

Analog I/O Characteristics

(V_{ddA} = 5.0 V_{dc} +/- 10%, T_J = -40 to +125 °C).

The Analog I/O characteristics of this device are shown below.

Characteristic	Min	Typ	Max	Unit
Input Impedance on Mic & Aux ^a	46	78	1400	kΩ
Input Capacitance on Mic and Aux	—	—	10	pF
Peak Input Voltage on the Mic/Aux Input for Full Scale Linearity (0.14dBm ^{0b}):				
-6dB- MGS1-0=00	—	—	1.414	V _p
0dB- MGS1-0=01	—	—	0.707	V _p
6dB- MGS1-0=10	—	—	354	mV _p
17dB- MGS1-0=11	—	—	100	mV _p
Internal Input Gain Variation; G=-6dB, 0dB, 6dB or 17dB (±0.83dB variation due to 10% variation on V _{dd}):	G-0.83	G	G+0.83	dB
V _{ref} Output Voltage	1.8	2	2.2	V
V _{ref} Output Current	—	—	±1	mA
DC offset between Spkout1 and Spkout2	—	—	100	mV
Allowable Differential Load Capacitance on Spkout1/2 (with 1kΩ in series)	0	—	50	nF
Allowable Single-ended Load Capacitance on Spkout1/2 (with 0.5kΩ in series)	0 ^c	—	100	nF
Maximum Single-ended Signal Output Level	—	—	1	V _p
Maximum Differential Signal Output Level	—	—	2	V _p
Single-ended Load Resistance	500	—	—	Ω
Differential Load Resistance	1	—	—	kΩ
R bias	—	10 ^d	—	kΩ
Internal Output Volume Control Variation VC=-20,-15,-10,-5,0,6,12,18,24,30,35 dB (±0.83dB variation due to 10% variation on V _{dd})	VC-0.83	VC	VC+0.83	dB

a. Min. value reached for a codec clock of 3MHz, typ. for 2MHz and max. for 100KHz

b. 0dBm⁰ corresponds to 3.14dB below the input saturation level

c. AC coupling is necessary in single-ended mode when the load resistor is not tied to V_{ref}

d. ±10%

Analog I/O Figure 1. describes the recommended analog I/O and power supply configurations.

The two analog inputs are electrically identical. When one is not used, it can be left floating. When used, an AC coupling capacitor is required. The value of the capacitor along with the input impedance of the pin determine the cut off frequency of a high pass filter. The input impedance of the MIC and AUX varies as a function of the $\Sigma\Delta$ modulator master clock. 78 k Ω is a typical value at 2MHz. An AC capacitor of 1 μ F defines a high pass filter pole of 2 Hz. A smaller capacitor value will move this pole higher in frequency.

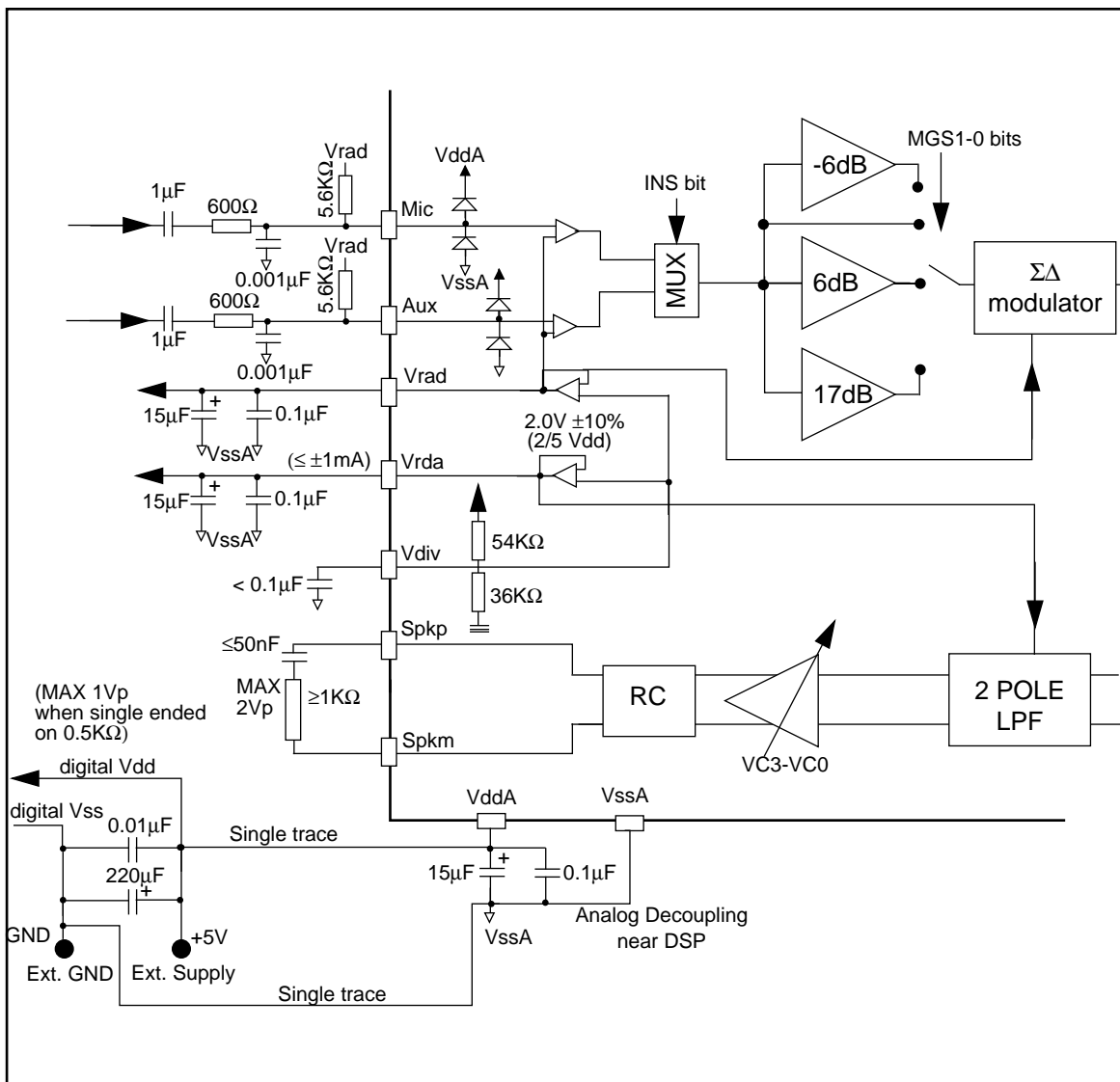

Analog I/O Figure 1. Recommended Analog I/O Configuration

Analog I/O Figure 2. shows three possible single-ended output configurations. Configuration (a) is highly recommended. For configuration (b) and (c), since the load resistor is tied to VssA, an AC coupling capacitor is required.

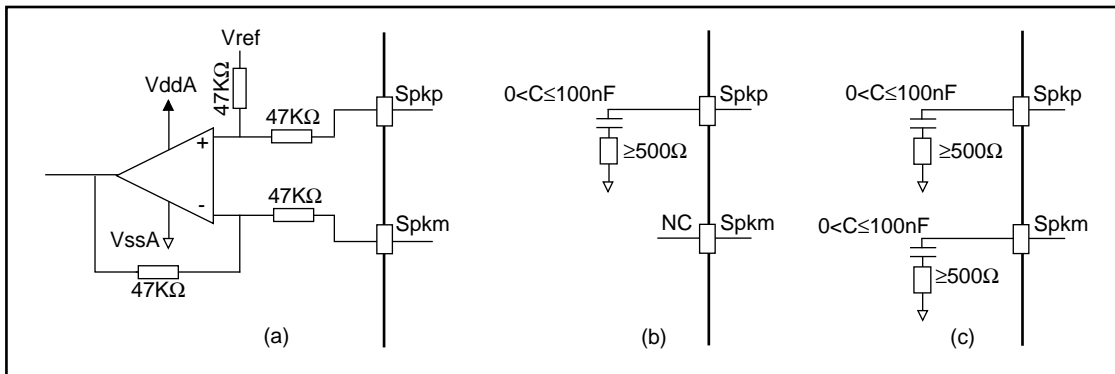

Analog I/O Figure 2. Single-ended Output Configurations

A/D and D/A Performances

(V_{ddA} = 5.0 Vdc +/- 10%, T_J = -40 to +125 °C).

The A/D and D/A performances of the codec section are given below.

Characteristic	Level	Min.	Typ. ^a	Max.	Unit
Analog to Digital Section Signal to Noise plus Distortion Ratio (S/N+T)	0dBm0 ^b	tbd	65	—	dB
	-10dBm0	tbd	60	—	dB
	-20dBm0	tbd	50	—	dB
	-50dBm0	tbd	20	—	dB
Digital to Analog Section Signal to Noise plus Distortion Ratio (S/N+T)	0dB	tbd	60	—	dB
	-10dB	tbd	55	—	dB
	-20dB	tbd	45	—	dB
	-50dB	tbd	15	—	dB

a. 0dB gain on the A/D and D/A; Codec clock at 2.048MHz with 128 decimation/interpolation ratio

b. 0dBm0 corresponds to -3.14dB below the input saturation level

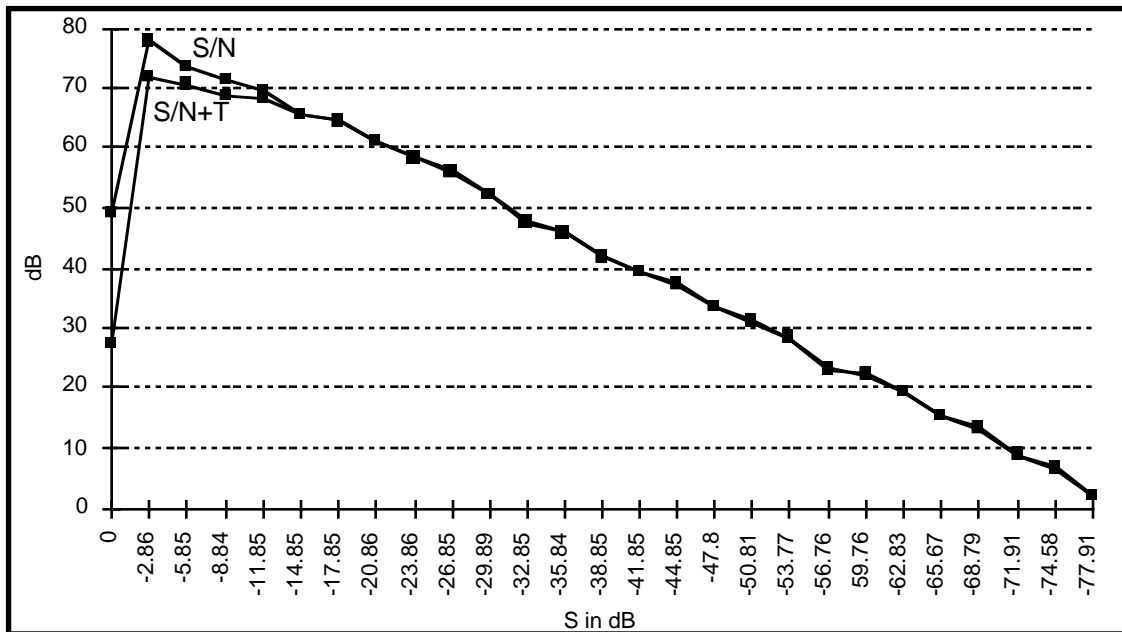

Analog I/O Figure 3. Example: S/N & S/N+T Performance for the A/D section

Other On-Chip Codec Characteristics

(V_{ddA} = 5.0 Vdc +/- 10%, T_J = -40 to +125 °C, C_L = 50 pF + 1 TTL Load).

The Analog I/O characteristics of this device are shown below.

Characteristic	Min	Typ	Max	Unit
Codec Master Clock	0.1	2.048	3	MHz
Codec Sampling rate	78	16000	46150	Hz
A/D section settling time	—	—	tbd	msec
D/A section settling time	—	—	tbd	msec
A/D section group delay	—	—	0.2	msec
D/A section group delay	—	—	0.2	msec
A/D to D/A Crosstalk	—	—	tbd	dB
D/A to A/D Crosstalk	—	—	tbd	dBm ₀
Idle noise at the D/A output	—	—	tbd	μV _{rms}
Idle noise at the A/D digital output	—	—	tbd	dBm ₀

DC Electrical Characteristics (VSS = 0 Vdc)

(Vdd = 5.0 Vdc +/- 10%, TJ = -40 to +125 °C, CL = 50 pF + 1 TTL Load).

The DC electrical characteristics of this device are shown below.

Characteristic	Symbol	Min	Typ	Max	Unit
Input High Voltage Except EXTAL, $\overline{\text{RESET}}$, MODA, MODB, MODC	VIH	2.0	—	Vdd	V
Input Low Voltage Except EXTAL, MODA, MODB, MODC	VIL	-0.5	—	0.8	V
Input High Voltage EXTAL DC coupled EXTAL AC coupled (see note 1)	VIHC	70% of Vdd 1	— —	Vdd Vdd	V
Input Low Voltage EXTAL DC coupled EXTAL AC coupled (see note 1)	VILC	-0.5 -0.5	— —	20% of Vdd Vdd-1	V
Input High Voltage $\overline{\text{RESET}}$	VIHR	2.5	—	Vdd	V
Input High Voltage MODA, MODB, MODC	VIHM	3.5	—	Vdd	V
Input Low Voltage MODA, MODB, MODC	VILM	-0.5	—	2.0	V
Input Leakage Current EXTAL, $\overline{\text{RESET}}$, MODA, MODB, $\overline{\text{BR}}$	Iin	-1	—	1	uA
Three-State (Off-State) Input Current (@2.4 V/0.5 V)	TSI	-10	—	10	uA
Output High Voltage (IOH = -10 uA)	VOHC	Vdd - 0.1	—	—	V
Output High Voltage (IOH = -0.4 mA)	VOH	2.4	—	—	V
Output Low Voltage (IOL = 10 uA)	VOLC	—	—	0.1	V
Output Low Voltage (IOL = 3.2 mA; R/W IOL = 1.6 mA; Open Drain $\overline{\text{HREQ}}$ IOL = 6.7 mA, TXD IOL = 6.7 mA)	VOL	—	—	0.4	V
Input Capacitance (see Note 2)	Cin	—	10	—	pF

NOTES:

1. When EXTAL is AC coupled, VIHC - VILC \geq 1V must be true.
2. Input capacitance is periodically sampled and not 100% tested in production.

AC Electrical Characteristics (VSS = 0 Vdc)

The timing waveforms in the **AC Electrical Characteristics** are tested with a VIL maximum of 0.5 V and a VIH minimum of 2.4 V for all pins, except EXTAL, RESET, MODA, MODB and MODC. These five pins are tested using the input levels set forth in the **DC Electrical Characteristics**. AC timing specifications which are referenced to a device input signal are measured in production with respect to the 50% point of the respective input signal's transition. The DSP56166 output levels are measured with the production test machine VOL and VOH reference levels set at 0.8 V and 2.0 V respectively.

AC Electrical Characteristics — Clock Operation Timing

The system clock to the DSP56166 must be externally supplied to EXTAL.

Num	Characteristics	Sym	60MHz		Unit
			Min	Max	
1	Frequency of Operation (EXTAL)	f	0	60	MHz
2	Instruction Cycle Time =2Tc	Icyc	33	∞	ns
3	Wait State =Tc =2T	WS	16.6	∞	ns
4	EXTAL Cycle Period	Tc	16.6	∞	ns
5	EXTAL Rise Time (see Note 1)		—	3	ns
6	EXTAL Fall Time (see Note 1)		—	3	ns
7	EXTAL Width High (see Note 2, 3, 4) 48-52% duty cycle	Th	8	∞	ns
8	EXTAL Width Low (see Note 2, 3, 4) 48%-52% duty cycle	TI	8	∞	ns

Notes:

1. Rise and Fall time may be relaxed to 12 ns maximum if the EXTAL input frequency is less than or equal to 20MHz. If the EXTAL input frequency is between 20MHz and 40MHz, Rise and Fall time should be 4 ns maximum. If the EXTAL input frequency is between 40MHz and 60MHz, Rise and Fall time should meet the specified values in the 40MHz column (3 ns maximum).
2. The duty cycle may be relaxed to 43-57% if the EXTAL input frequency is less than or equal to 20MHz. If the EXTAL input frequency is between 20MHz and 40MHz, the duty cycle should be such that Th and TI meet 12 ns minimum . If the EXTAL input frequency is between 40MHz and 60MHz, the duty cycle should be such that Th and TI meet the specified values in the 60MHz column (8 ns minimum) .
3. $T = I_{cyc} / 4$ is used in the electrical characteristics. The exact length of each T is affected by the duty cycle of the external clock input.
4. Duty cycles and EXTAL widths are measured at the EXTAL input signal midpoint when AC coupled and at Vdd/2 when not AC coupled.

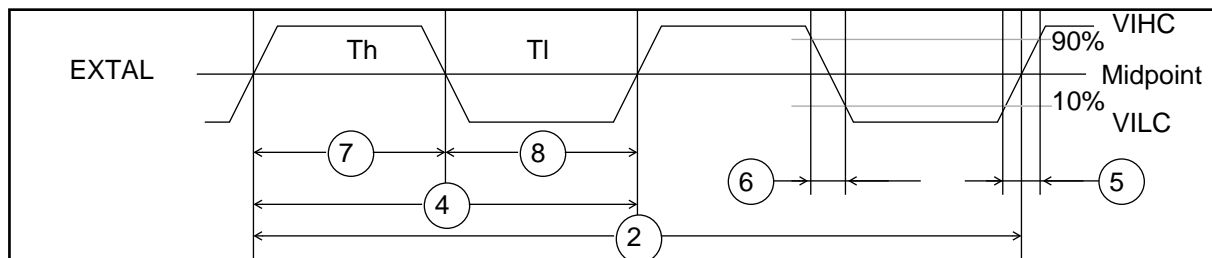

Clock Figure 1. External Clock Timing

AC Electrical Characteristics — Other Clock and PLL Operation Timing

Characteristics	Min	Max	Unit
PLL Output frequency	10	Max Fosc ^a	MHz
EXTAL Input Clock Amplitude ^b	1	Vdd	Vpp

- a. Maximum DSP operating frequency. See Operating Conditions.
- b. An AC coupling capacitor is required on EXTAL if the levels are out of the normal CMOS level range (VILC > 20% of Vdd or VIH < 70% of Vdd).

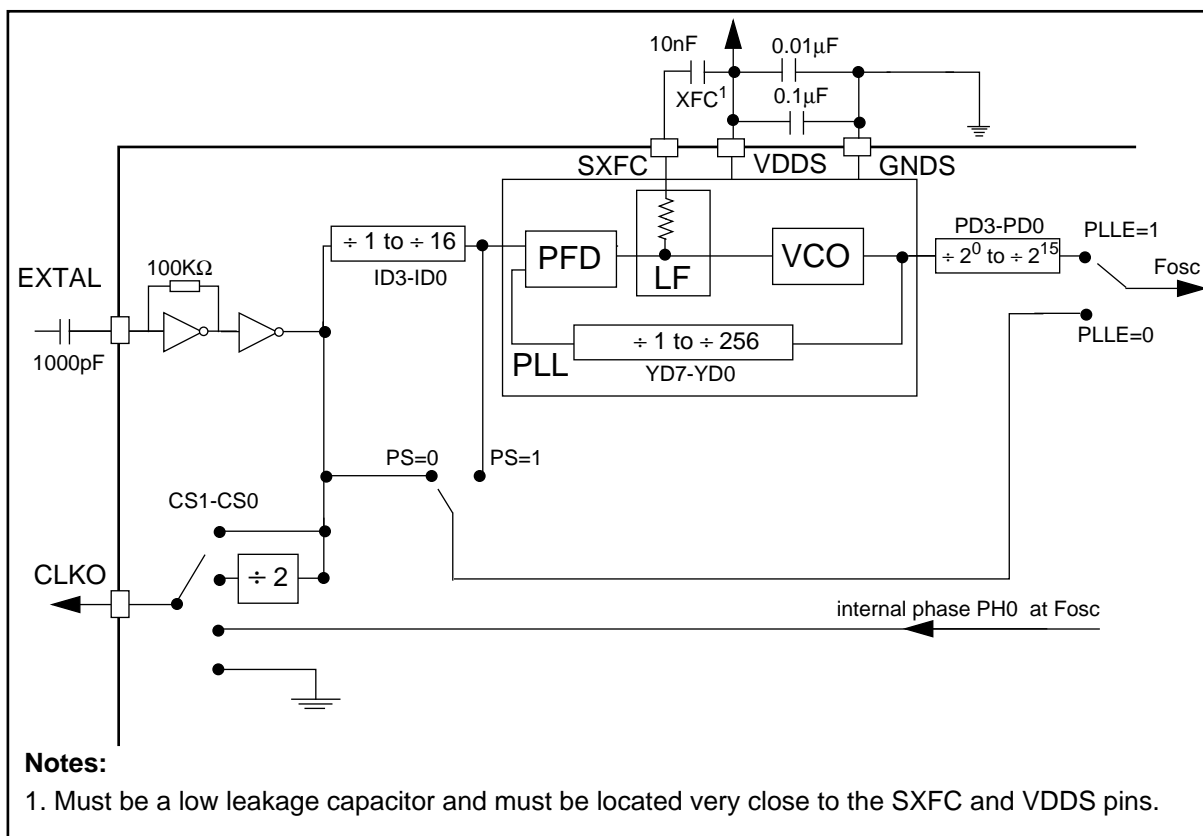

Clock Figure 2. Clocking Configurations

AC Electrical Characteristics**— Reset, Stop, Wait, Mode Select, and Interrupt Timing**(V_{dd} = 5.0 Vdc +/- 10%, T_J = -40 to +125 °C, CL = 50 pF + 1 TTL Load).

cyc = Clock cycle = 1/2 instruction cycle = 2 T cycles

ws= Number of wait states programmed into external bus access using BCR (WS = 0 - 31)

Num	Characteristics	60MHz		Unit
		Min	Max	
10	RESET Assertion to Address, Data and control signals High Impedance	—	21	ns
11	Minimum Stabilization Duration(see Note 1) OMR bit6=0 OMR bit6=1	600KT	—	ns
		60T	—	ns
12	Asynchronous $\overline{\text{RESET}}$ Deassertion to First External Address Output (see note 7)	16T	18T +15	ns
13	Synchronous Reset Setup Time from $\overline{\text{RESET}}$ Deassertion to Rising Edge of CLK0	5	cyc-2	ns
14	Synchronous Reset Delay Time from CLK0 High to the First External Access (see note 7)	16T +3	16T +16	ns
15	Mode Select Setup Time	4.8	—	ns
16	Mode Select Hold Time	0.8	—	ns
17	Edge-Triggered Interrupt Request Width	3.7	—	ns
18	Delay from $\overline{\text{IRQA}}$, $\overline{\text{IRQB}}$, $\overline{\text{IRQC}}$ Assertion to External Data Memory Access Out Valid - Caused by First Interrupt Instruction Fetch - Caused by First Interrupt Instruction Execution	11T+3	—	ns
		19T+3	—	ns
19	Delay from $\overline{\text{IRQA}}$, $\overline{\text{IRQB}}$, $\overline{\text{IRQC}}$ Assertion to General Purpose	22T	—	ns

AC Electrical Characteristics**— Reset, Stop, Wait, Mode Select, and Interrupt Timing (Continued)**(V_{dd} = 5.0 Vdc +/- 10%, T_J = -40 to +125 °C, C_L = 50 pF + 1 TTL Load).

Num	Characteristics	60MHz		Unit
		Min	Max	
21	Delay from General-Purpose Output Valid Caused by the Execution of the First Interrupt Instruction to $\overline{\text{IRQA}}$, $\overline{\text{IRQB}}$, $\overline{\text{IRQC}}$ Deassertion for Level Sensitive Fast Interrupts — If 2nd Interrupt Instruction is: Single Cycle (see note 2)	—	cyc-26	ns
	Two Cycles	—	3cyc-26	ns
22	Synchronous setup time from $\overline{\text{IRQA}}$, $\overline{\text{IRQB}}$, $\overline{\text{IRQC}}$ assertion to Synchronous falling edge of CLK0 (see note 5, 6)	0	1	ns
23	Falling Edge of CLK0 to First Interrupt Vector Address Out Valid after Synchronous recovery from Wait State (see Note 3, 5)	27T+3	27T+16	ns
24	$\overline{\text{IRQA}}$ Width Assertion to Recover from STOP State(see note 4)	3.6	—	ns
25	Delay from $\overline{\text{IRQA}}$ Assertion to Fetch of first instruction (exiting STOP) OMR bit 6 = 0 (see note1,3)	524303T+3	—	ns
	OMR bit 6 = 1	47T+3	—	ns
28	Duration for Level Sensitive $\overline{\text{IRQA}}$ Assertion to Cause the Fetch of First $\overline{\text{IRQA}}$ Interrupt Instruction (exiting STOP) (see note1,3)			
	OMR bit 6 = 0	524303T	—	ns
	OMR bit 6 = 1	47T	—	ns
29	Delay from Level Sensitive $\overline{\text{IRQA}}$ Assertion to First Interrupt Vector Address Out Valid (exiting STOP) (see note1, 3)			
	OMR bit 6 = 0	524303T+3	—	ns
	OMR bit 6 = 1	47T+3	—	ns

Notes:

1. Circuit stabilization delay is required during reset when using an external clock in two cases:
 - 1) after power-on reset, and
 - 2) when recovering from Stop mode.

2. When using fast interrupts and \overline{IRQA} and \overline{IRQB} are defined as **level-sensitive**, then timings 20 & 21 apply to prevent multiple interrupt service. To avoid these timing restrictions, the negative edge-triggered mode is recommended when using fast interrupt. Long interrupts are recommended when using level-sensitive mode.
3. The interrupt instruction fetch is visible on the pins only in Mode 3.
4. The minimum is specified for the duration of an edge triggered \overline{IRQA} interrupt required to recover from the STOP state. This is not the minimum required so that the \overline{IRQA} interrupt is accepted.
5. Timing #22 is for all IRQx interrupts while timing #23 is only when exiting WAIT
6. Timing #22 triggers off T1 in the normal state and off phi1 when exiting the WAIT state.
7. The instruction fetch is visible on the pins only in Mode 2 and Mode 3.

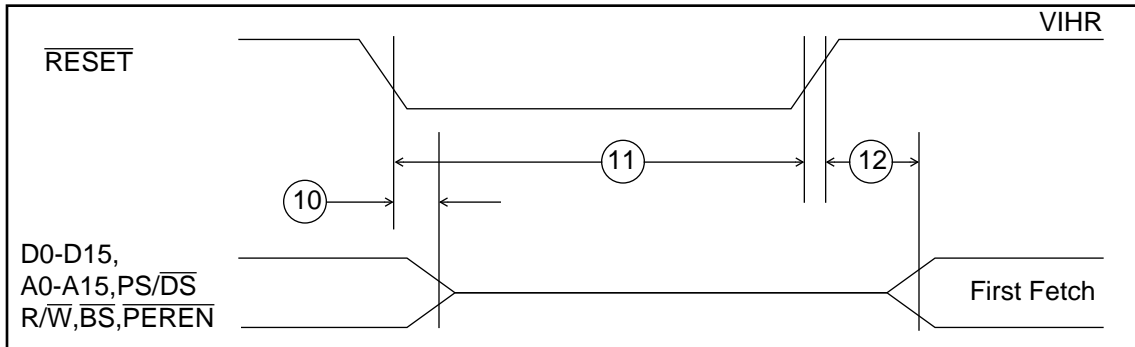

Interrupt Figure 1. Asynchronous Reset Timing

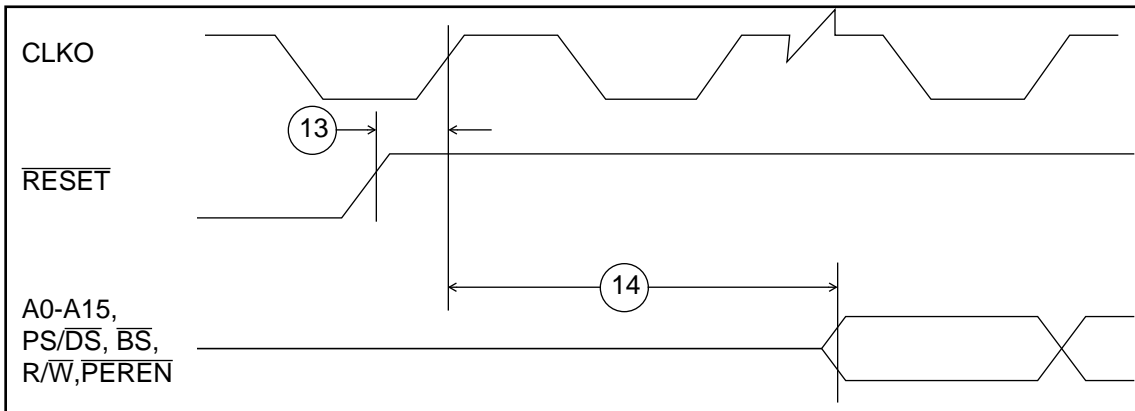

Interrupt Figure 2. Synchronous Reset Timing

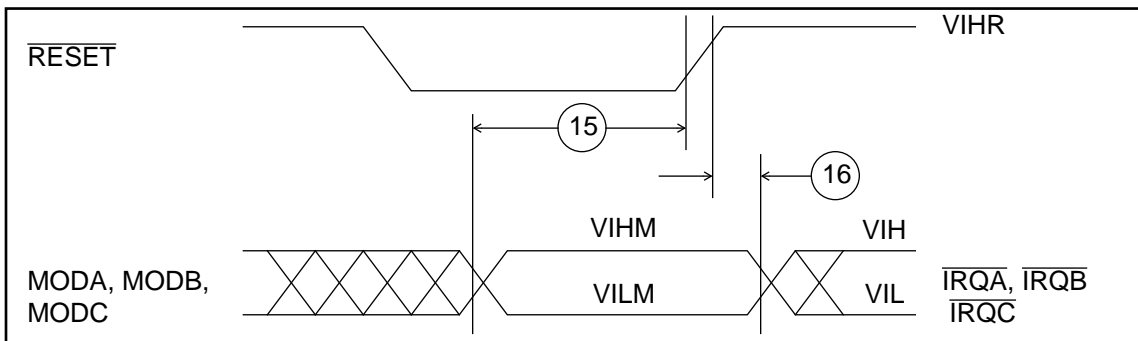

Interrupt Figure 3. Operating Mode Select Timing

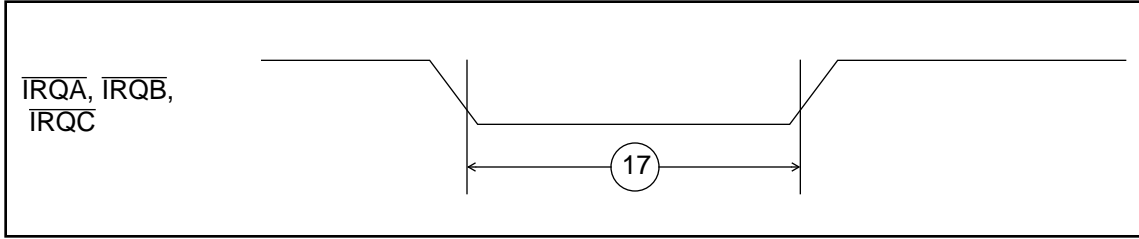

Interrupt Figure 4. External Interrupt Timing (Negative Edge-Triggered)

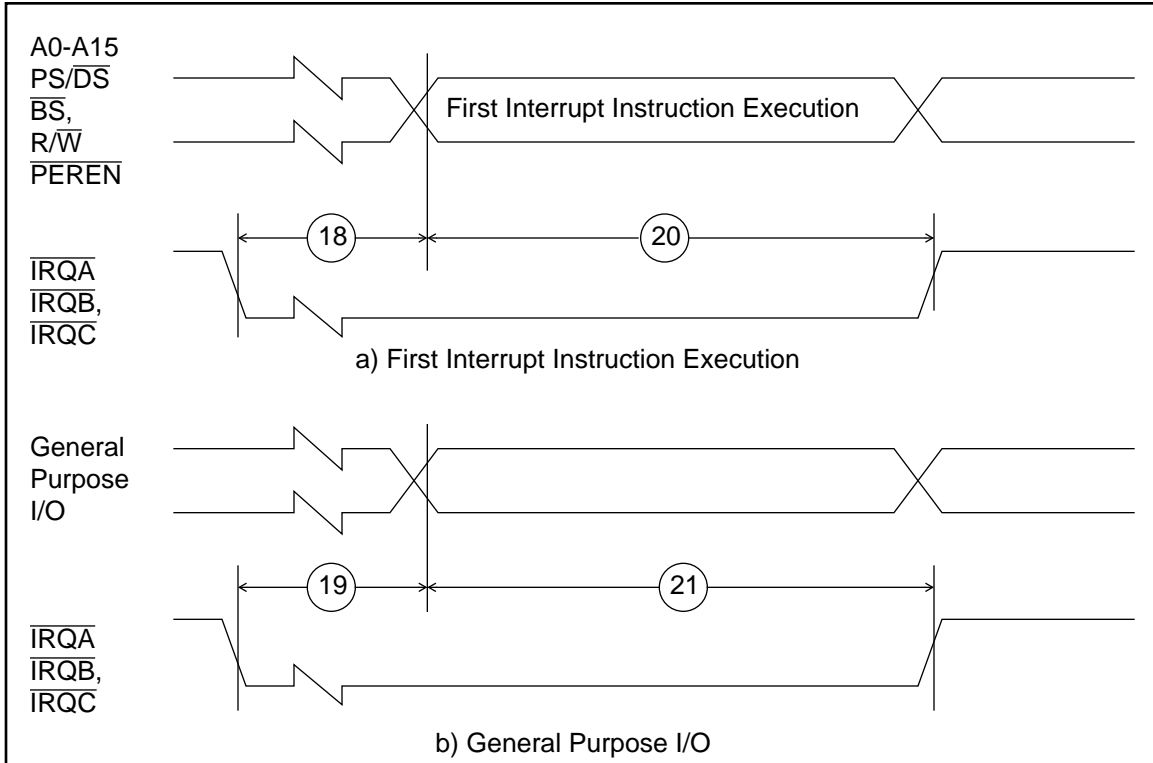

Interrupt Figure 5. External Level-Sensitive Fast Interrupt Timing

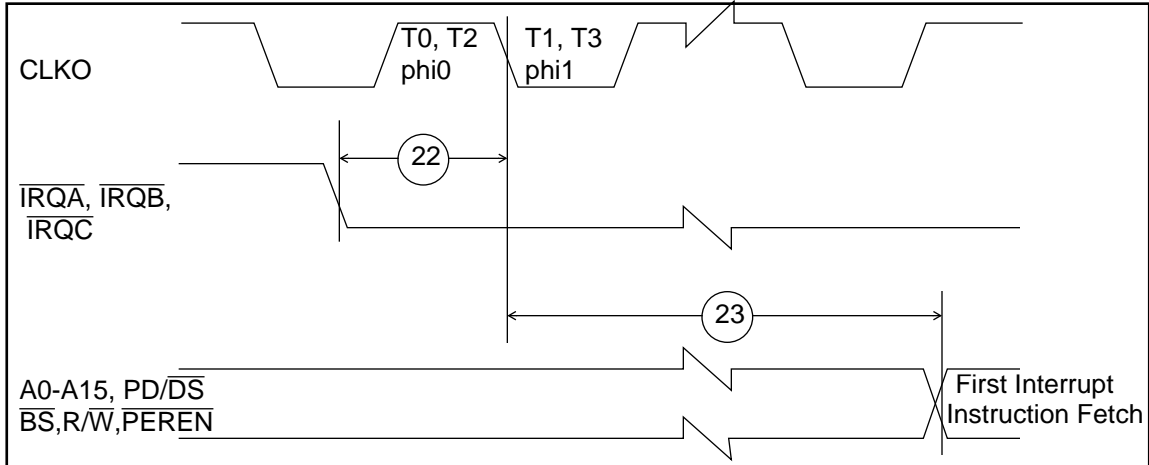

Wait and Stop 1. Synchronous Interrupt from Wait State Timing

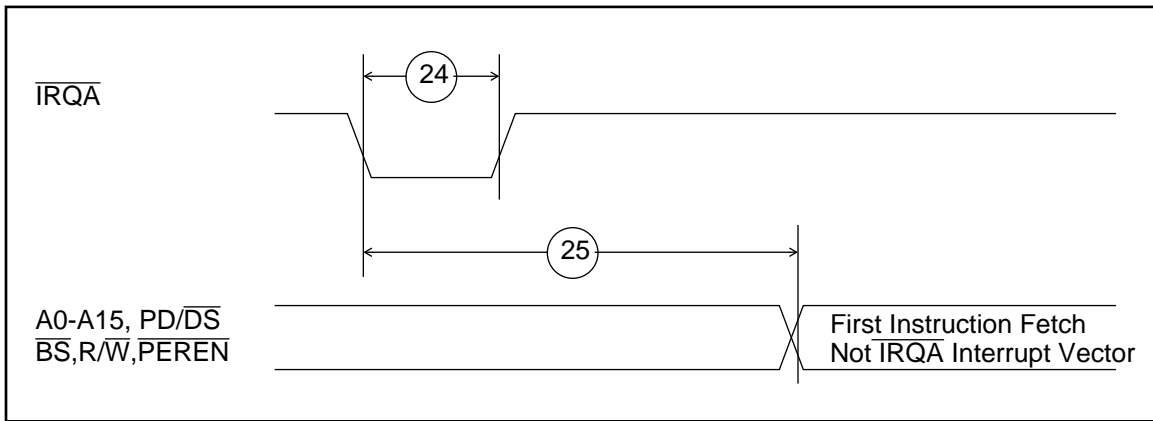

**Wait and Stop 2.
Recovery from STOP State using Asynchronous Interrupt Timing**

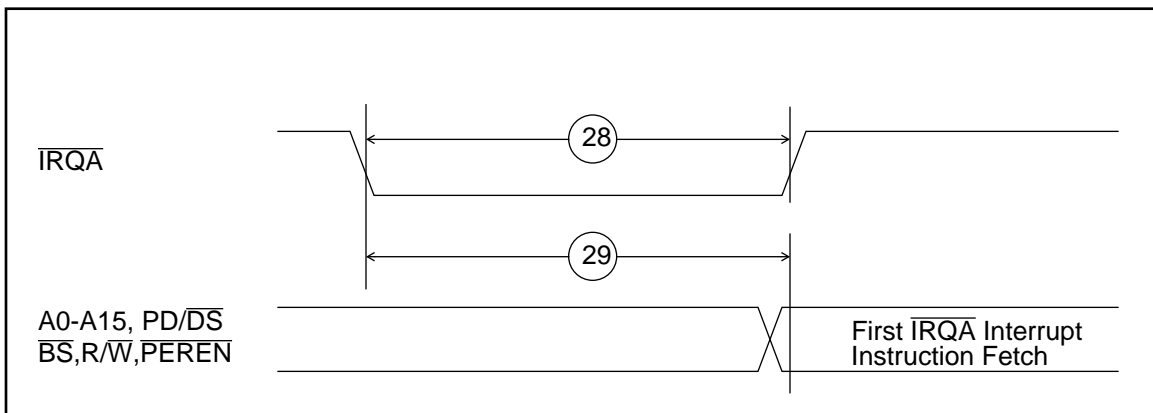

**Wait and Stop 3.
Recovery from Stop State Using IRQA Interrupt Service**

AC Electrical Characteristics — Wait and Stop Timings (Continued)

Num	Characteristics	60MHz		Unit
		Min	Max	
30	\overline{DR} Asserted to CLK low (Setup Time for Synchronous Recovery from Wait State)	8	cyc+8	ns
31	CLK low to DSO (\overline{ACK}) Valid (Enter Debug Mode) After Synchronous Recovery from Wait State	18cyc	—	ns

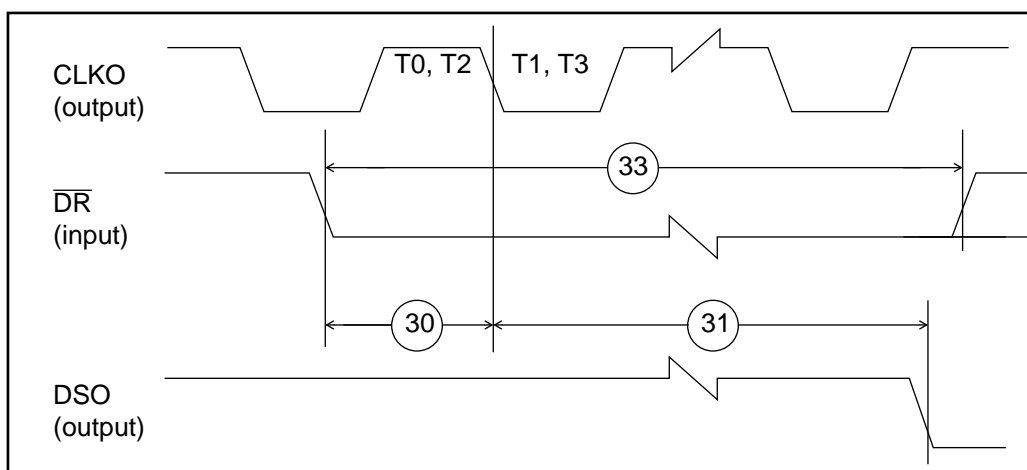

Wait and Stop 4.
Recovery from WAIT State Using \overline{DR} Pin— Synchronous Timing

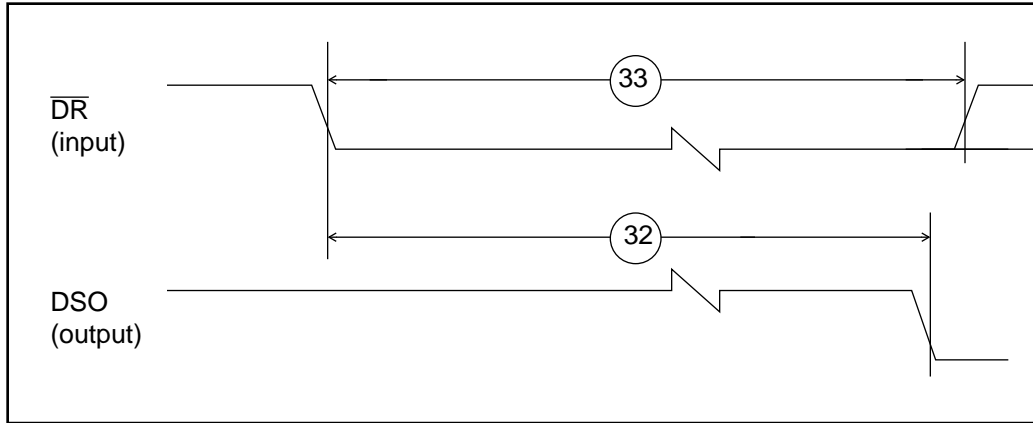

Wait and Stop 5.
Recovery from WAIT/STOP State Using \overline{DR} Pin— Asynchronous Timing

AC Electrical Characteristics

Capacitance Derating —External Bus Synchronous Timing

VCC = 5.0 Vdc +/- 10%, T_J = -40 to +125° C, CL = 50 pF + 1 TTL Load.

The DSP56166 External Bus Timing Specifications are designed and tested at the maximum capacitive load of 50 pF, including stray capacitance. Typically, the drive capability of the External Bus pins (A0-A15, D0-D23, PS/ \overline{DS} , \overline{RD} , \overline{WR} , R/ \overline{W} , BS, \overline{PEREN}) derates linearly at 1 ns per 12 pF of additional capacitance from 50 pF to 250 pF of loading. Port B and C pins derate linearly at 1 ns per 5 pF of additional capacitance from 50 pF to 250 pF of loading.

When an internal memory access follows an external memory access, the $\overline{PS/\overline{DS}}$, R/ \overline{W} , \overline{RD} , \overline{WR} , \overline{BS} and \overline{PEREN} strobes remain deasserted and A0-A15 do not change from their previous state.

Num	Characteristic	60MHz		Unit
		Min	Max	
34	CLK in (EXTAL) High to CLKO High			ns
35	CLKO High to a. A0-A15 Valid b. PS/DS, PEREN Assertion, R/W Valid c. BS Assertion d. RD Assertion		5.8 8.7 8.7 8.3	ns ns ns ns
36	BS Width Deassertion	14.6	—	ns
37	CLKO High to WR Assertion Low		T+ 6.0	ns
38				
39				
40	CLKO High to BS Deassertion	1.5		ns
41	a. TA Assertion to CLKO High (Setup) b. TA Deassertion to CLKO High (Setup)	5.9	— —	ns ns
42	a. CLKO High to TA Assertion (Hold) b. CLKO High to TA Deassertion (Hold)	8.3	— —	ns ns
43	CLKO High to D0-D15 Out Valid		8.8	ns
44	CLKO High to D0-D15 Out Invalid (Hold)	1.6	—	ns
45	D0-D15 In Valid to CLKO Low (Setup)	2.5	—	ns
46	CLKO Low to D0-D15 In Invalid (Hold)	0.1	—	ns
47	CLKO Low to a. WR Deassertion b. RD Deassertion	— —	4.8 4.0	ns ns
48	a. WR Hold Time from CLKO Low b. RD Hold Time from CLKO Low	1.6 0.5	— —	ns ns
49	CLKO High to D0-D15 Three-state		TBD	ns
50	CLKO High to D0-D15 Out Active	TBD		ns
51	CLKO High to a. A0-A15 Invalid b. PS/DS, PEREN, R/W Invalid	1.1 2.2		ns ns

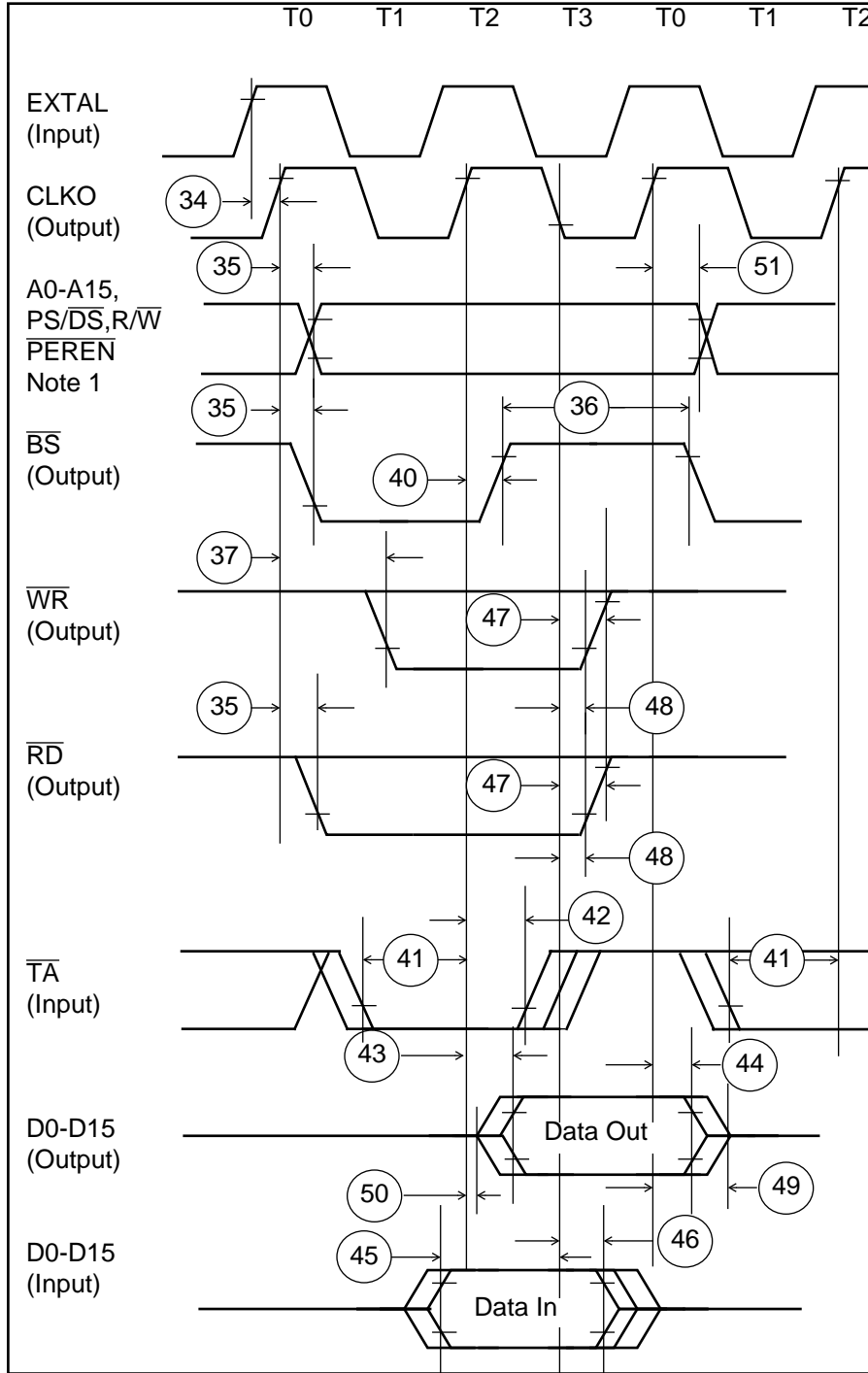

External Bus Figure 1. External Bus Synchronous Timing — No Wait States

Note 1: During Read-Modify-Write instructions and internal instructions, the address lines do not change state

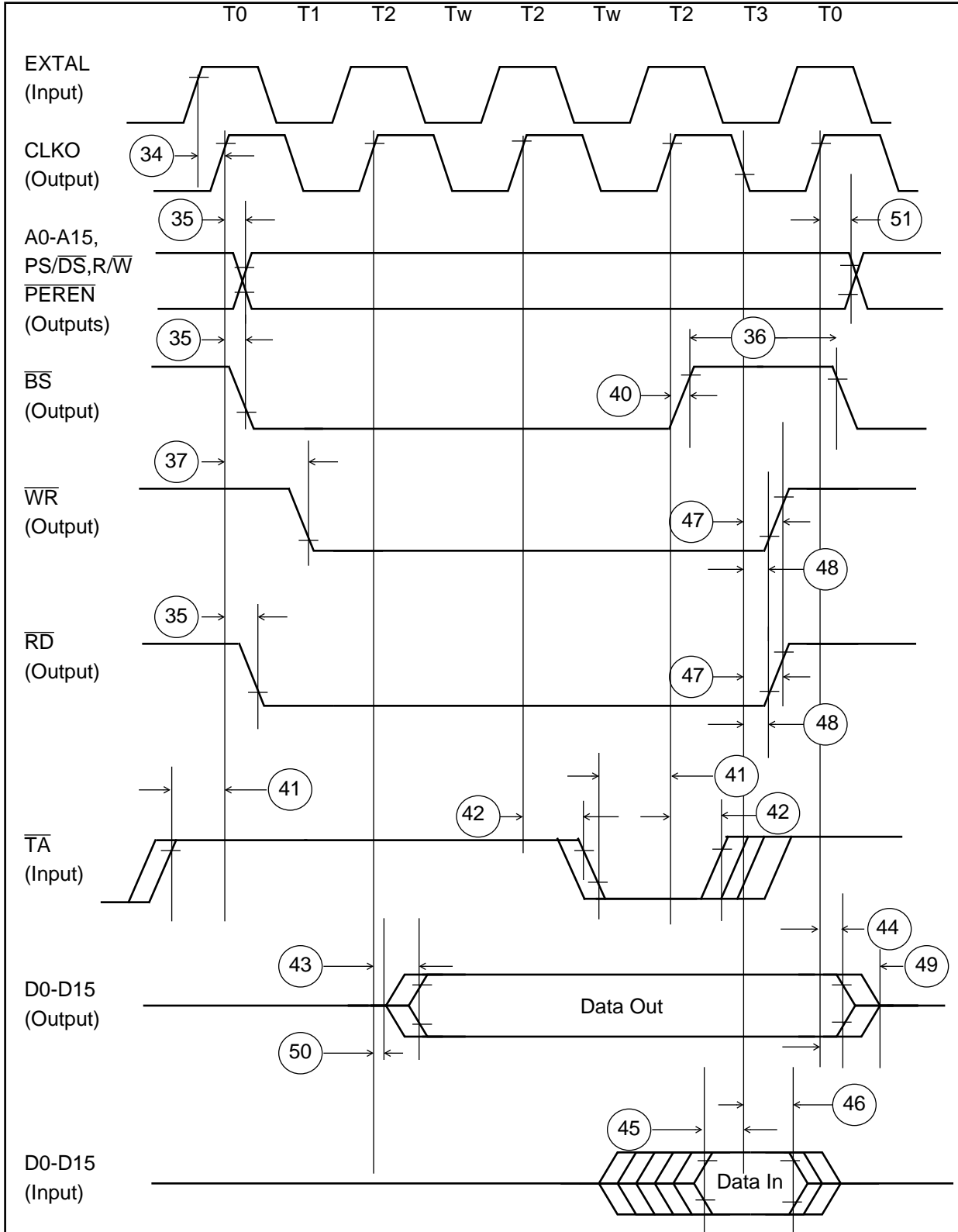

External Bus Figure 2. External Bus Synchronous Timing – Two Wait States

AC Electrical Characteristics

External Bus Asynchronous Timing

VCC = 5.0 Vdc +/- 10%, T_J = -40 to +125° C, CL = 50 pF + 1 TTL Load.

cyc = Clock cycle = 1/2 instruction cycle = 2 T cycles

WS = Number of Wait States, Determined by BCR Register (WS = 0 to 31)

WT = WS*cyc=2T*WS

Num	Characteristic	60MHz		Unit
		Min	Max	
52	\overline{WR} and \overline{RD} Deassertion High to \overline{BS} Assertion Low (2 Successive Bus Cycles)	TBD	TBD	ns
53	Address Valid to \overline{WR} Assertion	TBD	TBD	ns
54	\overline{WR} Width Assertion WS=0 WS>0	TBD	— —	ns
55	\overline{WR} Deassertion to R/\overline{W} , Address Invalid	TBD	—	ns
56	\overline{WR} Assertion to D0-D15 Out Valid	TBD	TBD	ns
57	Data Out Hold Time from \overline{WR} Deassertion	TBD	TBD	ns
58	Data Out Set up Time to \overline{WR} Deassertion WS=0 WS>0	TBD	— —	ns
59	\overline{RD} Deassertion to Adress not valid	TBD	—	ns
60	Address valid to \overline{RD} Deassertion	TBD	—	ns
61	Input data hold to \overline{RD} Deassertion	TBD	—	ns
62	\overline{RD} Assertion width WS=0 WS>0	TBD	— —	ns
63	Address valid to input data valid WS=0 WS>0	— —	TBD	ns
64	Address valid to \overline{RD} Assertion		TBD	ns
65	\overline{RD} Assertion to input data valid WS=0 WS>0	— —	TBD	ns
66	\overline{WR} Deassertion to \overline{RD} Assertion	TBD	—	ns
67	\overline{RD} Deassertion to \overline{RD} Assertion	TBD	—	ns
68	\overline{WR} Deassertion to \overline{WR} Assertion	TBD	—	ns
69	\overline{RD} Deassertion to \overline{WR} Assertion	TBD	—	ns

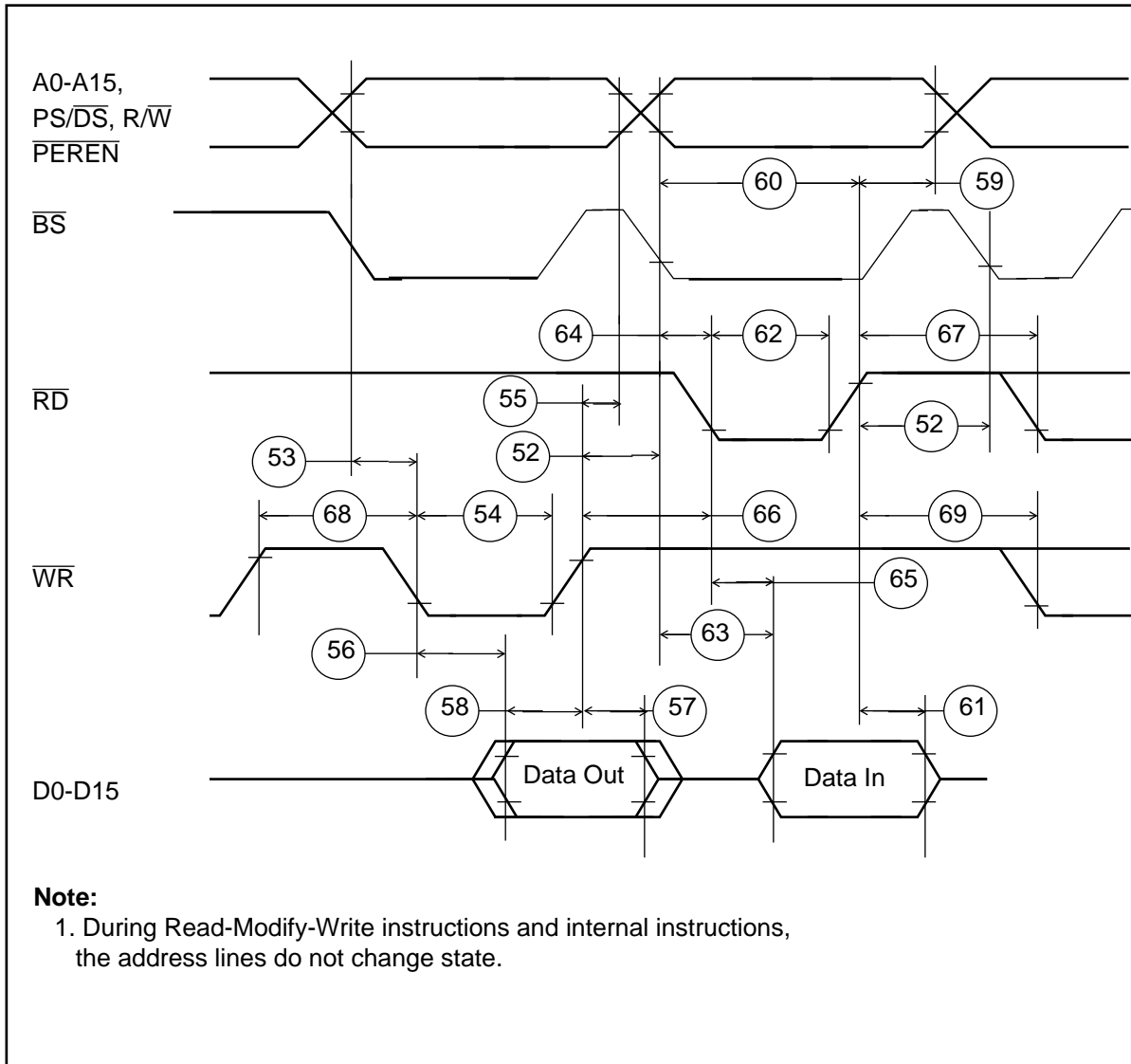

External Bus Figure 3. External Bus Asynchronous Timing

AC Electrical Characteristics — Bus Arbitration Timing — Slave Mode

VCC = 5.0 Vdc +/- 10%, T_J = -40 to +125° C, CL = 50 pF + 1 TTL Load.

cyc = Clock cycle = 1/2 instruction cycle = 2 T cycles

WS = Number of Wait States for X or P external memory, Determined by BCR or BCR2 Registers (WS = 0 to 31)

WT = WS*cyc=2T*WS

Wx = Number of Wait States for X external memory, Determined by BCR or BCR2 Registers (WS = 0 to 31)

Wp = Number of Wait States for P external memory, Determined by BCR Register (WS = 0 to 31)

Num	Characteristics	60 MHz		Unit
		Min	Max	
70	\overline{BR} Input to CLK0 low setup time	2.8		ns
71	Delay from \overline{BR} Input Assertion (See note 1) to \overline{BG} Output Assertion (See note 2) (See note 3) (See note 4) (See note 5)		TBD TBD TBD TBD TBD	ns ns ns ns ns
72	CLK0 high to \overline{BG} Output Assertion		7.2	ns
73	\overline{BG} Output Deassertion duration (See note 1) for two consecutive \overline{BR} (See note 2) (See note 3) (See note 4) (See note 5) (See note 7)	TBD TBD TBD TBD TBD	— — — — —	ns ns ns ns ns
74	CLK0 High to Control Bus high impedance		TBD	ns
75	CLK0 High to \overline{BB} Output Deassertion	10.3		ns
76	CLK0 High to \overline{BB} Output (Three-state)		TBD	ns
77	\overline{BR} Input Deassertion to (See note 1) \overline{BG} Output Deassertion (See note 5) (See note 7)		TBD TBD TBD	ns ns ns
78	CLK0 High to \overline{BG} Deassertion		2.0	ns
79	CLK0 High to \overline{BB} Output Active	TBD		ns
80	CLK0 High to \overline{BB} Output Assertion		8.5	ns
81	CLK0 High to Address and Control Bus Active	TBD		ns
82	CLK0 High to Address and Control Bus Valid		8.5	ns

Num	Characteristics	60 MHz		Unit
		Min	Max	
83	\overline{BR} Assertion to	(See note 1)	TBD	ns
	\overline{BB} Deassertion	(See note 2)	TBD	ns
		(See note 3)	TBD	ns
		(See note 4)	TBD	ns
		(See note 5)	TBD	ns
84	\overline{BR} Assertion to	(See note 1)	TBD	ns
	Addr/Data/Control Three-state	(See note 2)	TBD	ns
		(See note 3)	TBD	ns
		(See note 4)	TBD	ns
		(See note 5)	TBD	ns

NOTES:

1. With no external access from the DSP56166
2. During external read or write access
3. During external read-modify-write access
4. During STOP mode — external bus is released and \overline{BG} is always low
5. During WAIT mode
7. With external accesses pending by the DSP56166
8. Slave mode, when bus is still busy after bus request has been deasserted

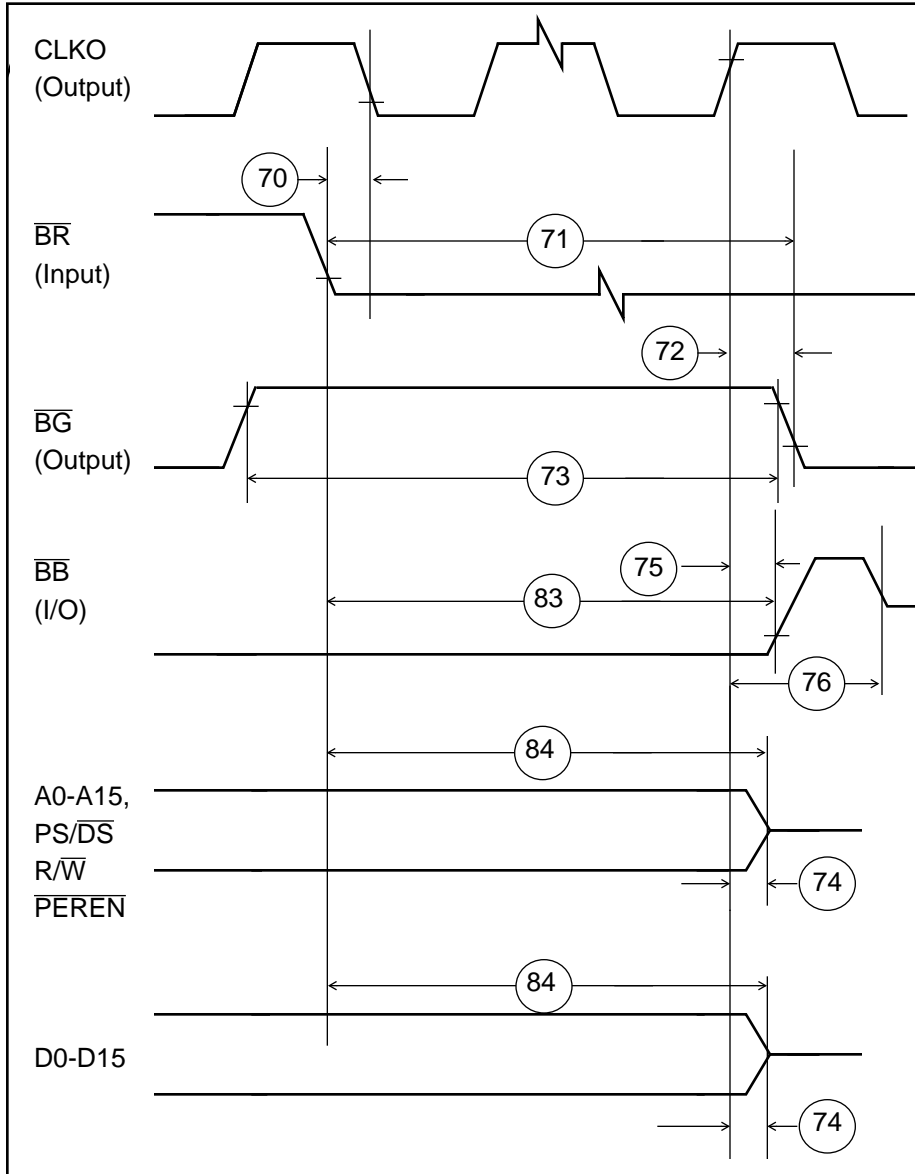

External Bus Figure 4. Bus Arbitration Timing — Slave Mode — Bus Release.

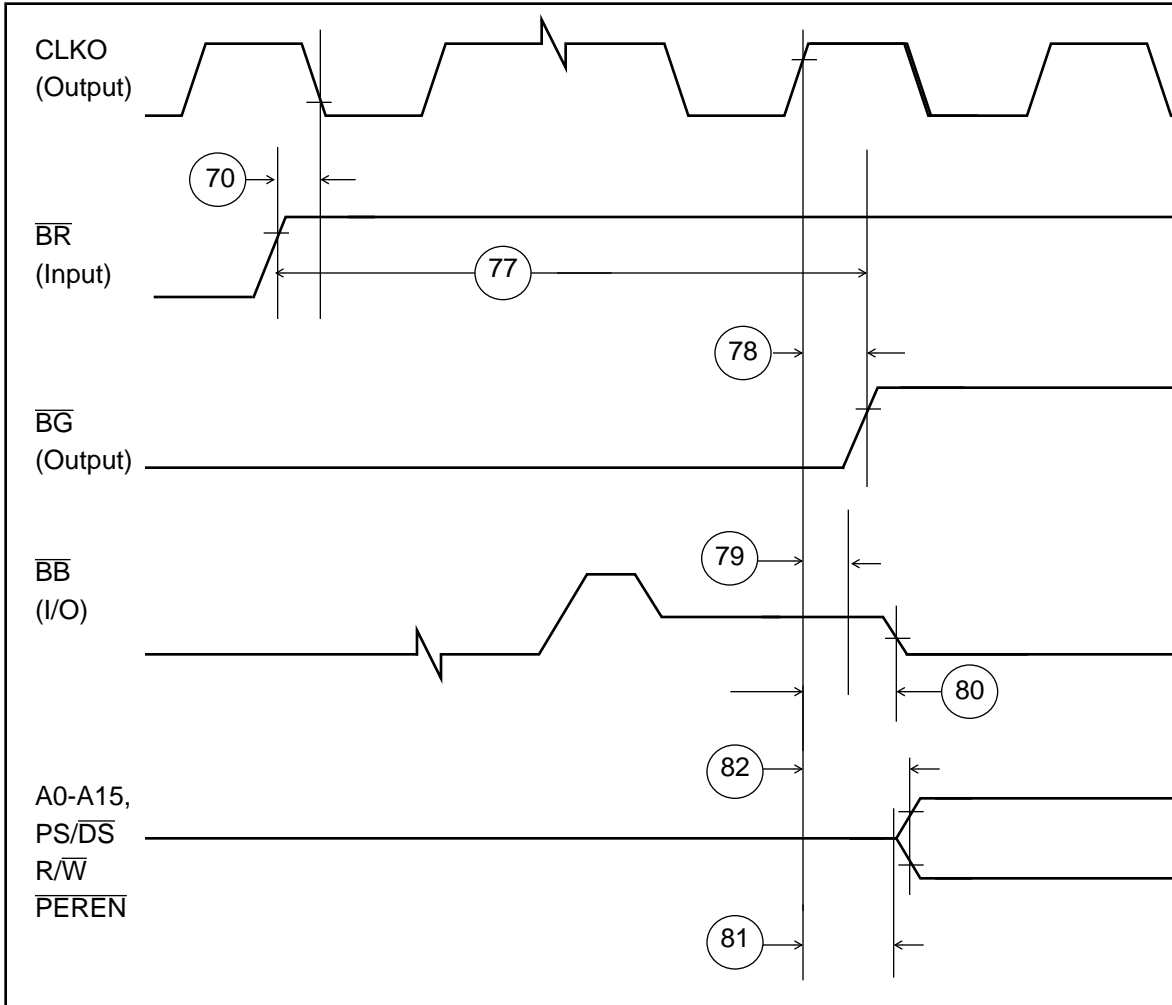

**External Bus Figure 5.
Bus Arbitration Timing — Slave Mode — Bus Acquisition.**

AC Electrical Characteristics — Bus Arbitration Timing — Master ModeVCC = 5.0 Vdc +/- 10%, T_J = -40 to +125° C, CL = 50 pF + 1 TTL Load.

Num	Characteristic	60MHz		Unit
		Min	Max	
85	CLKO high to $\overline{B}\overline{R}$ Output Valid		7.3	ns
86	$\overline{B}\overline{G}$ Input Valid to CLKO Low (Setup)	1.7	—	ns
87	CLKO Low to $\overline{B}\overline{G}$ Input Deassertion (Hold)	TBD	—	ns
88	$\overline{B}\overline{B}$ Input Deassertion to CLKO Low (Setup)	1.5	—	ns
89	CLKO Low to $\overline{B}\overline{B}$ Input Deassertion (Hold)	TBD	—	ns
90	CLKO High to $\overline{B}\overline{B}$ Output Assertion		8.0	ns
91	CLKO Low to $\overline{B}\overline{G}$ Input Assertion (See note 1) (See note 2)	TBD	—	ns
		TBD	—	ns
92	$\overline{B}\overline{G}$ Deassertion to $\overline{B}\overline{B}$ Deassertion (See note 1) (See note 2) (See note 3) (See note 4) (See note 5)		TBD	ns
			TBD	ns
			TBD	ns
			TBD	ns
			TBD	ns
93	$\overline{B}\overline{G}$ Deassertion to Addr/Data/Control Three-state (See note 1) (See note 2) (See note 3) (See note 4) (See note 5)		TBD	ns
			TBD	ns
			TBD	ns
			TBD	ns
			TBD	ns

NOTES:

1. With no external access from the DSP56166
2. During external read or write access
3. During external read-modify-write access
4. During STOP mode — external bus is released and $\overline{B}\overline{G}$ is always low
5. During WAIT mode

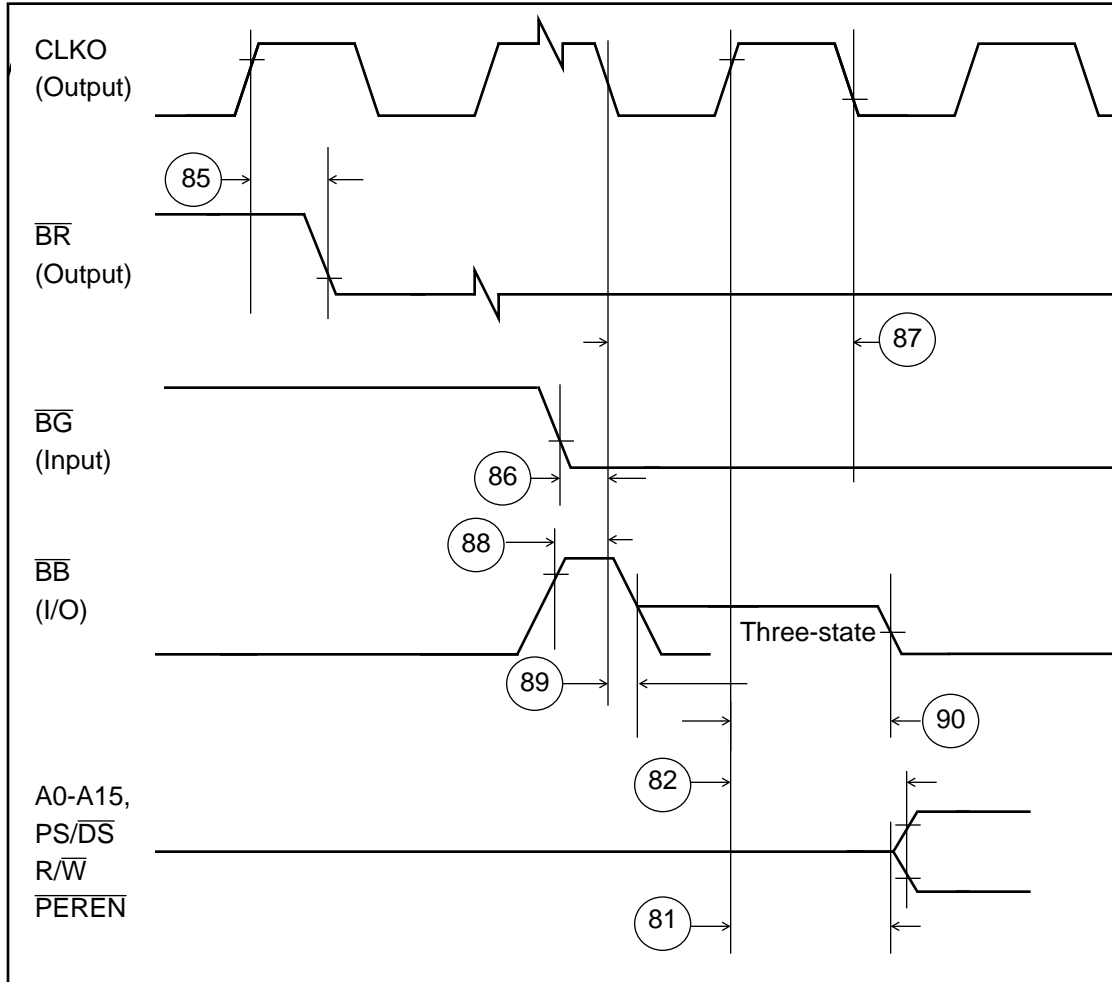

**External Bus Figure 6.
Bus Arbitration Timing — Master Mode — Bus Acquisition.**

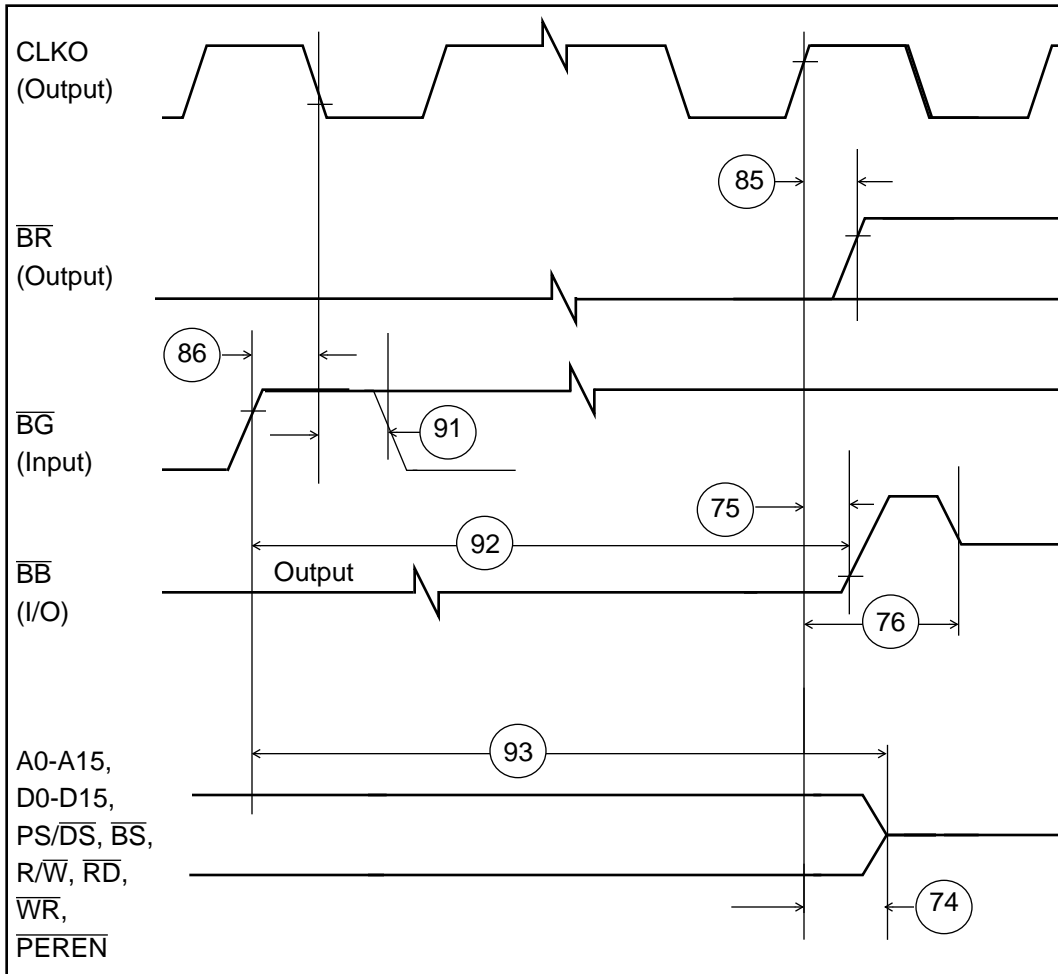

**External Bus Figure 7.
Bus Arbitration Timing — Master Mode — Bus Release.**

HOST PORT USAGE CONSIDERATIONS

Careful synchronization is required when reading multibit registers that are written by another asynchronous system. This is a common problem when two asynchronous systems are connected. The situation exists in the Host port. The considerations for proper operation are discussed below.

Host Programmer Considerations

1. **Unsynchronized Reading of Receive Byte Registers**
When reading receive byte registers, RXH or RXL, the Host programmer should use interrupts or poll the RXDF flag which indicates that data is available. This assures that the data in the receive byte registers will be stable.
2. **Overwriting Transmit Byte Registers**
The Host programmer should not write to the transmit byte registers, TXH or TXL, unless the TXDE bit is set indicating that the transmit byte registers are empty. This guarantees that the transmit byte registers will transfer valid data to the HRX register.
3. **Synchronization of Status Bits from DSP to Host**
HC, HREQ, DMA, HF3, HF2, TRDY, TXDE, and RXDF (refer to DSP56166 User's Manual, I/O Interface section, Host/DMA Interface Programming Model for descriptions of these status bits) status bits are set or cleared from inside the DSP and read by the Host processor. The Host can read these status bits very quickly without regard to the clock rate used by the DSP, but the possibility exists that the state of the bit could be changing during the read operation. This is generally not a system problem, since the bit will be read correctly in the next pass of any Host polling routine.

However, if the Host asserts the $\overline{\text{HEN}}$ for more than timing number 101 (T101), with a minimum cycle time of timing number 103 (T103), then the status is guaranteed to be stable

A potential problem exists when reading status bits HF3 and HF2 as an encoded pair. If the DSP changes HF3 and HF2 from 00 to 11, there is a small probability that the Host could read the bits during the transition and receive 01 or 10 instead of 11. If the combination of HF3 and HF2 has significance, the Host could read the wrong combination.

Solution:

- a. Read the bits twice and check for consensus.
 - b. Assert $\overline{\text{HEN}}$ access for T101a so that status bit transitions are stabilized.
4. **Overwriting the Host Vector**
The Host programmer should change the Host Vector register only when the Host Command bit (HC) is clear. This change will guarantee that the DSP interrupt control logic will receive a stable vector.
 5. **Cancelling a Pending Host Command Exception**
The Host processor may elect to clear the HC bit to cancel the Host Command Exception request at any time before it is recognized by the DSP. Because the Host does not know exactly when the exception will be recognized (due to exception processing synchronization and pipeline delays), the DSP may execute the Host exception after the HC bit is cleared. For these reasons, the HV bits must not be changed at the same time the HC bit is cleared.

DSP Programmer Considerations

1. **Reading HF0 and HF1 as an Encoded Pair**
DMA, HF1, HF0, and HCP, HTDE, and HRDF (refer to DSP56166 User's Manual, I/O Interface section, Host/DMA Interface Programming Model for descriptions of these status bits) status bits are set or cleared by the Host processor side of the interface. These bits are individually synchronized to the DSP clock.

A potential problem exists when reading status bits HF1 and HF2 as an encoded pair, i.e., the four combinations 00, 01, 10, and 11 each have significance. A very small probability exists that the DSP will read the status bits synchronized during transition. The solution to this potential problem is to read the bits twice for consensus.

AC Electrical Characteristics — Host I/O Timing

(VCC = 5.0 Vdc +/- 10%, TJ = -40° to +125° C, CL = 50 pF + 1 TTL Load, see Host Figures 1 through 6)

T = $t_{cyc} / 4$

cyc = Clock cycle = 1/2 instruction cycle = 2 T cycle

tHSDL = Host Synchronization Delay Time

t_{suH} : Host processor data setup time

Active low lines should be "pulled up" in a manner consistent with the AC and DC specifications

Num	Characteristic	60MHz		Unit
		Min	Max	
100	Host Synchronous Delay (see Note 1)	T	3T	ns
101	$\overline{H\!E\!N}/\overline{H\!A\!C\!K}$ Assertion Width a. CVR, ICR, ISR Read (see Note 2,4) b. Read c. Write	2T+ 30 16+t _{suH} 8.0	— — —	ns
102	$\overline{H\!E\!N}/\overline{H\!A\!C\!K}$ Deassertion Width (see Note 2)	27	—	ns
103	Minimum Cycle Time Between Two $\overline{H\!E\!N}$ Assertion for Consecu- tive CVR, ICR, ISR reads	4T+ 30	—	ns
104	Host Data Input Setup Time Before $\overline{H\!E\!N}/\overline{H\!A\!C\!K}$ Deassertion	3	—	ns
105	Host Data Input Hold Time After $\overline{H\!E\!N}/\overline{H\!A\!C\!K}$ Deassertion	9	—	ns
106	$\overline{H\!E\!N}/\overline{H\!A\!C\!K}$ Assertion to Output Data Active from High Impedance	0	—	ns
107	$\overline{H\!E\!N}/\overline{H\!A\!C\!K}$ Assertion to Output Data Valid	—	24	ns
108	$\overline{H\!E\!N}/\overline{H\!A\!C\!K}$ Deassertion to Output Data High Impedance	—	17	ns
109	Output Data Hold Time After $\overline{H\!E\!N}/$ $\overline{H\!A\!C\!K}$ Deassertion	5	—	ns

AC Electrical Characteristics — Host I/O Timing (Continued)

Num	Characteristic	60MHz		Unit
		Min	Max	
110	HR/ \overline{W} Low Setup Time Before $\overline{H\overline{E}N}$ Assertion	4	—	ns
111	HR/ \overline{W} Low Hold Time After $\overline{H\overline{E}N}$ Deassertion	4	—	ns
112	HR/ \overline{W} High Setup Time to $\overline{H\overline{E}N}$ Assertion	4	—	ns
113	HR/ \overline{W} High Hold Time After $\overline{H\overline{E}N}/\overline{HACK}$ Deassertion	3	—	ns
114	HA0-HA2 Setup Time Before $\overline{H\overline{E}N}$ Assertion	0	—	ns
115	HA0-HA2 Hold Time After $\overline{H\overline{E}N}$ Deassertion	6	—	ns
116	DMA \overline{HACK} Assertion to \overline{HREQ} Deassertion(see Note 3)	4	2T+ 35	ns
117	DMA \overline{HACK} Deassertion to \overline{HREQ} Assertion(see Note 3)			
	for DMA RXL Read	$t_{HSDL} + 3T + 4$	—	ns
	for DMA TXL Write	$t_{HSDL} + 2T + 4$	—	ns
	for All Other Cases	4	—	ns
118	Delay from $\overline{H\overline{E}N}$ Deassertion to \overline{HREQ} Assertion for RXL Read (see Note 3)	$t_{HSDL} + 3T + 4$	—	ns
119	Delay from $\overline{H\overline{E}N}$ Deassertion to \overline{HREQ} Assertion for TXL Write (see Note 3)	$t_{HSDL} + 2T + 4$	—	ns
120	Delay from $\overline{H\overline{E}N}$ Assertion to \overline{HREQ} Deassertion for RXL Read, TXL Write (see Note 3)	13.7	2T+ 16.4	ns

NOTES:

1. "Host synchronization delay (t_{HSDL})" is the time period required for the DSP56166 to sample any external asynchronous input signal, determine whether it is high or low, and synchronize it to the internal clock.
2. See **HOST PORT USAGE CONSIDERATIONS**.
3. \overline{HREQ} is pulled up by 1k Ω .
4. Only if two consecutive reads from one of these registers are executed.

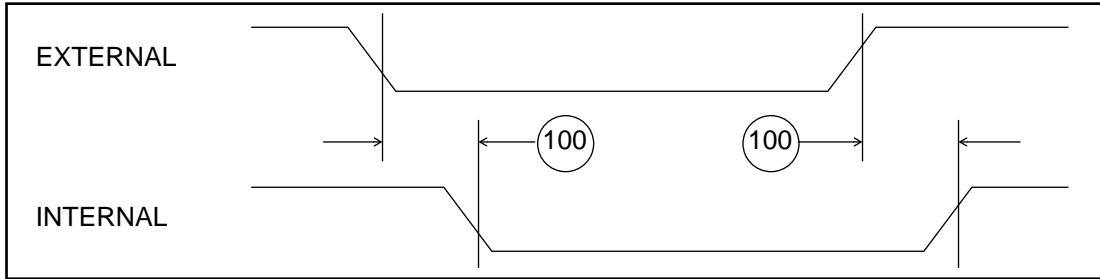

Host Figure 1. Host Synchronization Delay

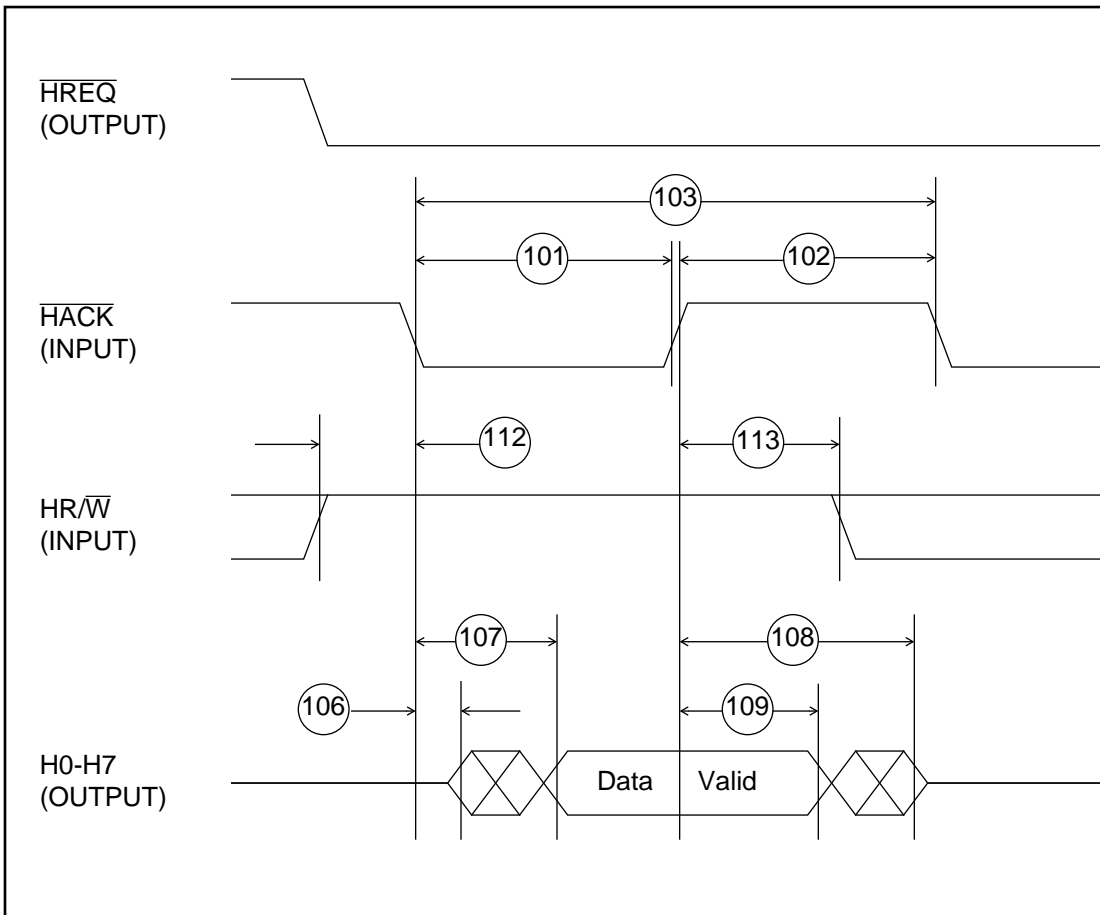

Host Figure 2. Host Interrupt Vector Register (IVR) Read

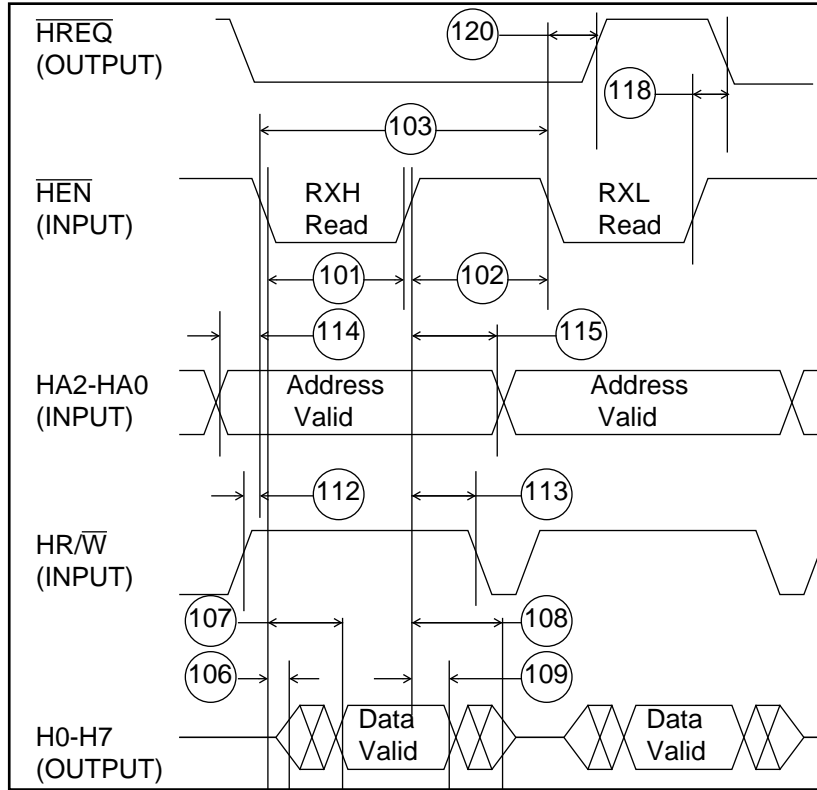

Host Figure 3. Host Read Cycle (Non-DMA Mode)

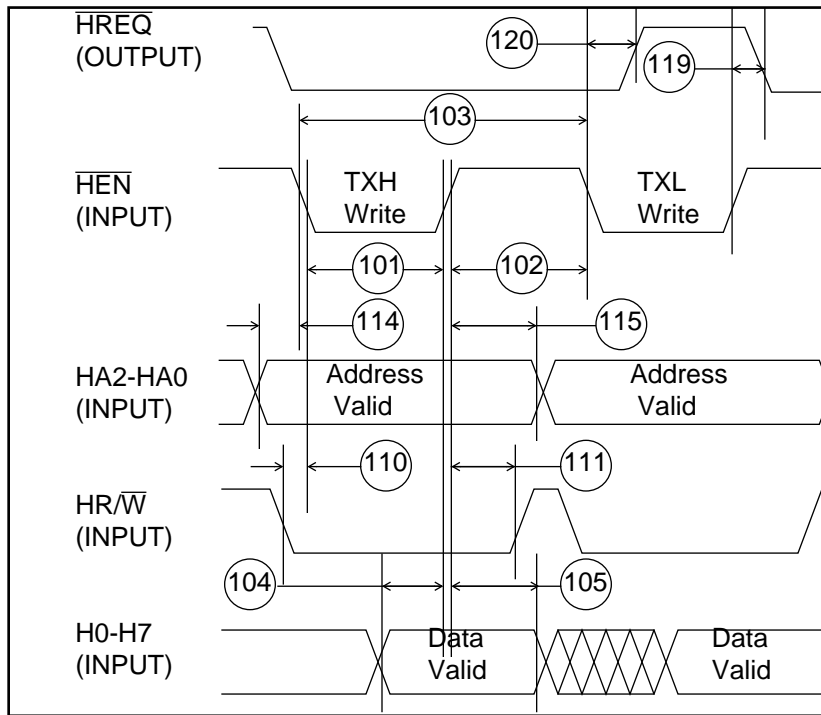

Host Figure 4. Host Write Cycle (Non-DMA Mode)

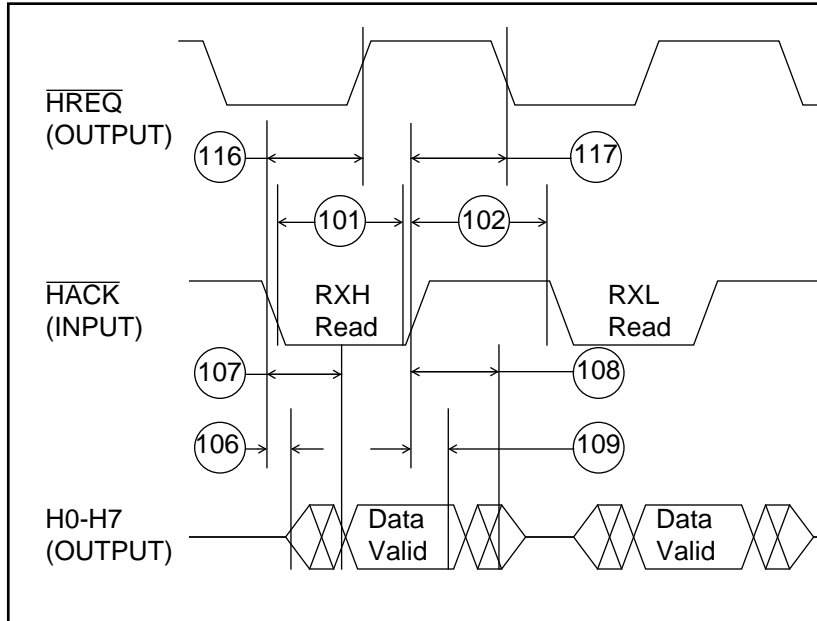

Host Figure 5. Host DMA Read Cycle

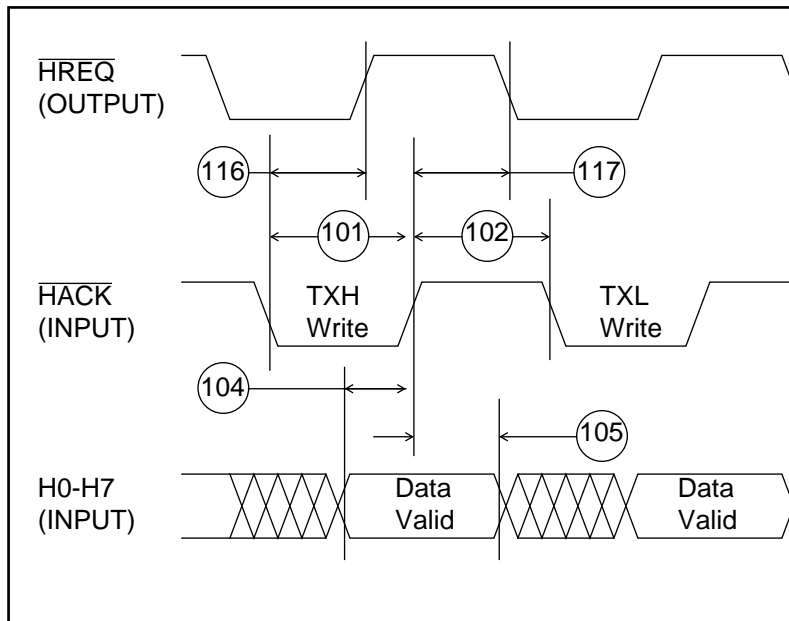

Host Figure 6. Host DMA Write Cycle

AC Electrical Characteristics — RSSI Timing

(VCC = 5.0 Vdc +/- 10%, TJ = -40° to + 125° C, CL = 50 pF + 1 TTL Load, see RSSI Figure 1 and 2)

$$T = t_{cyc} / 4$$

SCK Pin = Serial Clock

SFS Pin = Transmit/Receive Frame Sync

ick = Internal Clock and Frame Sync

xck = External Clock and Frame Sync

bl = bit length

wl = word length

NOTE:

All the timings for the RSSI are given for a non-inverted serial clock polarity (SCKP=0 in CRB) and a non-inverted frame sync (FSI=0 in CRB). If the polarity of the clock and/or the frame sync have been inverted, all the timings remain valid by inverting the clock signal SCK and/or the frame sync SFS in the tables and in the figures.

Num	Characteristic	60MHz		Case	Unit
		Min	Max		
130	SCK Clock Cycle (see Note 1)	TBD	—	ick	ns
131	SCK Clock High Period	TBD	—	ick	ns
132	SCK Clock Low Period	TBD	—	ick	ns
133	SCK Clock Rise/Fall Time	—	TBD	ick	ns
134	SCK Rising Edge to SFS In (bl) High	—	TBD	ick	ns
135	SCK Rising Edge to SFS In (bl) Low	—	TBD	ick	ns
136	SCK Rising Edge to SFS In (wl) High	—	TBD	ick	ns
137	SCK Rising Edge to SFS In (wl) Low	—	TBD	ick	ns
138	Data In Setup Time Before SCK Falling Edge	TBD	—	ick	ns
139	Data In Hold Time After SCK Falling Edge	TBD	—	ick	ns

AC Electrical Characteristics — RSSI Timing (Continued)

Num	Characteristic	60MHz		Case	Unit
		Min	Max		
140	SCK Rising Edge to SFS Out (bl) High	—	TBD	i ck	ns
141	SCK Rising Edge to SFS Out (wl) High	—	TBD	i ck	ns
142	SCK Rising Edge to SFS Out Low	—	TBD	i ck	ns
143	SCK Rising Edge to Data Out Enable from High Impedance	—	TBD	i ck	ns
144	SCK Rising Edge to Data Out Valid	—	TBD	i ck	ns
145	SCK Rising Edge to Data Out Invalid	—	TBD	i ck	ns
146	SCK Rising Edge to Data Out High Impedance	—	TBD	i ck	ns

NOTES:

1. For internal clock, Serial Clock Cycle is defined by I_{cyc} and RSSI control register.

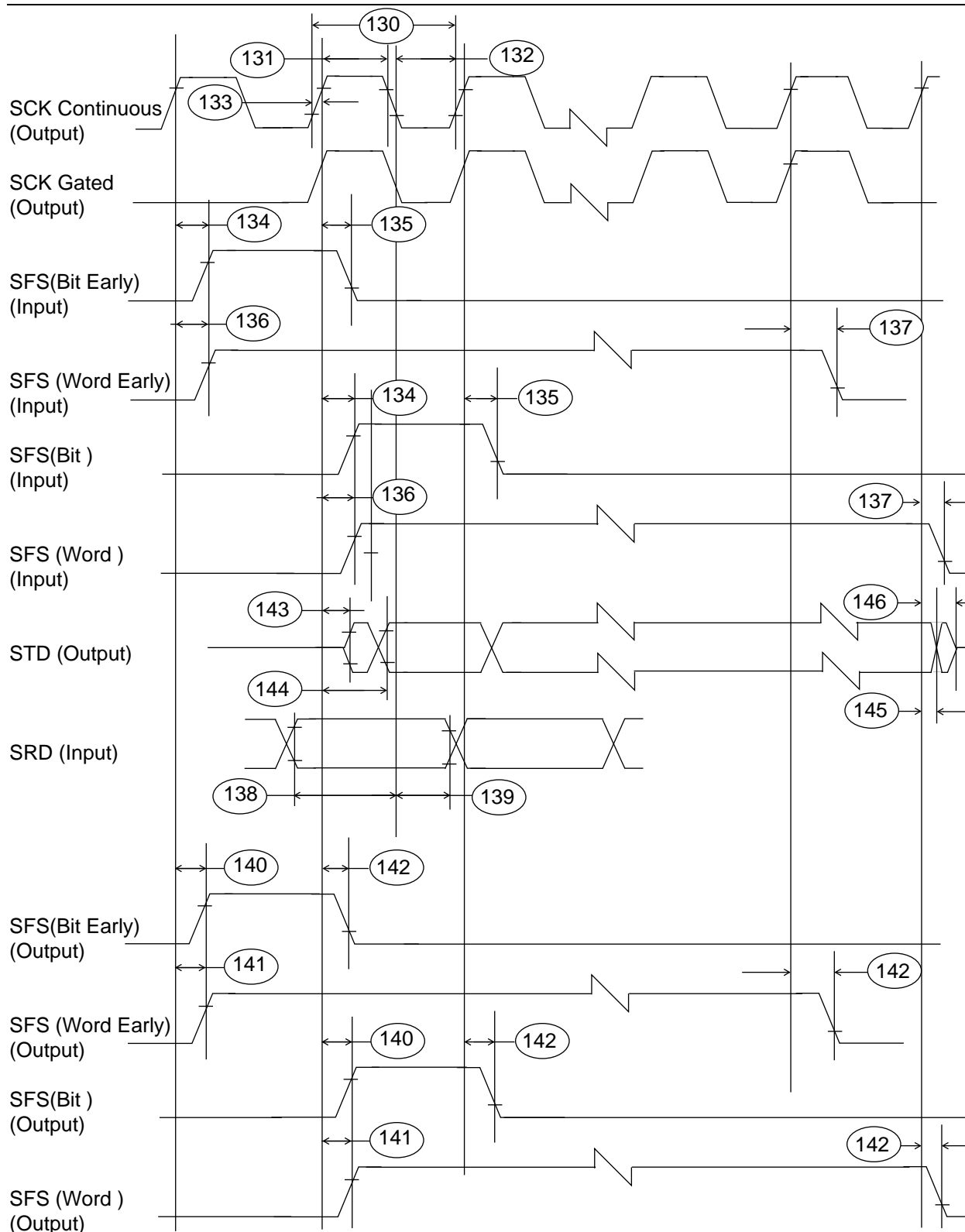

RSSI Figure 1. RSSI Internal ClockTiming

AC Electrical Characteristics — RSSI Timing (Continued)

Num	Characteristic	60MHz		Case	Unit
		Min	Max		
150	SCK Clock Cycle (see Note 1)	TBD	—	x ck	ns
151	SCK Clock High Period	TBD	—	x ck	ns
152	SCK Clock Low Period	TBD	—	x ck	ns
153	SCK Clock Rise/Fall Time	—	TBD	x ck	ns
154	SCK Rising Edge to SFS Out (bl) High	—	TBD	x ck	ns
155	SCK Rising Edge to SFS Out (bl) Low	—	TBD	x ck	ns
156	SCK Rising Edge to SFS Out (wl) High	—	TBD	x ck	ns
157	SCK Rising Edge to SFS Out (wl) Low	—	TBD	x ck	ns
158	Data In Setup Time Before SCK Falling Edge	TBD	—	x ck	ns
159	Data In Hold Time After SCK Falling Edge	TBD	—	x ck	ns
160	SCK Rising Edge to SFS In (bl) High	—	TBD	x ck	ns
161	SCK Rising Edge to SFS In (bl) Low	—	TBD	x ck	ns
162	SCK Rising Edge to SFS In (wl) High	—	TBD	x ck	ns
163	SCK Rising Edge to Data Out Enable from High Impedance	—	TBD	x ck	ns
164	SCK Rising Edge to Data Out Valid	—	TBD	x ck	ns
165	SCK Rising Edge to Data Out Invalid	—	TBD	x ck	ns
166	SCK Rising Edge to Data Out High Impedance	—	TBD	x ck	ns

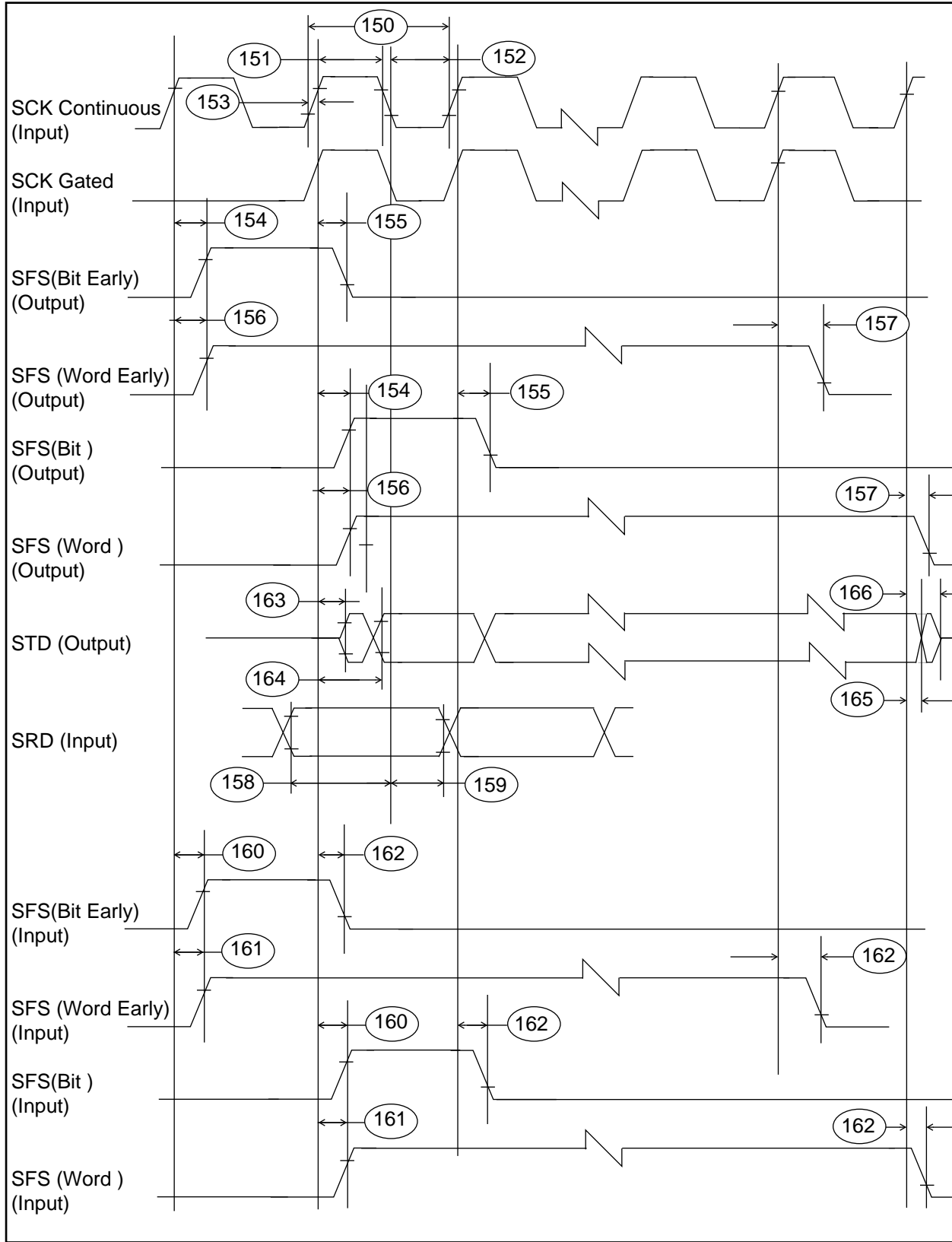

RSSI Figure 2. RSSI External ClockTiming

AC Electrical Characteristics — Timer Timing

(VCC = 5.0 Vdc +/- 10%, TJ = -40 to +125 °C, CL = 50 pF + 1 TTL Load).

Num	Characteristic	60MHz		Unit
		Min	Max	
170	TIN Valid to CLKO low (Setup time)	6	—	ns
171	CLKO Low to TIN Invalid (Hold time)	0	—	ns
172	CLKO High to TOUT Asserted	3.5	14	ns
173	CLKO High to TOUT Deasserted	5.1	20.7	ns
174	Tin Period	8T	—	ns
175	Tin High/Low Period	4T	—	ns

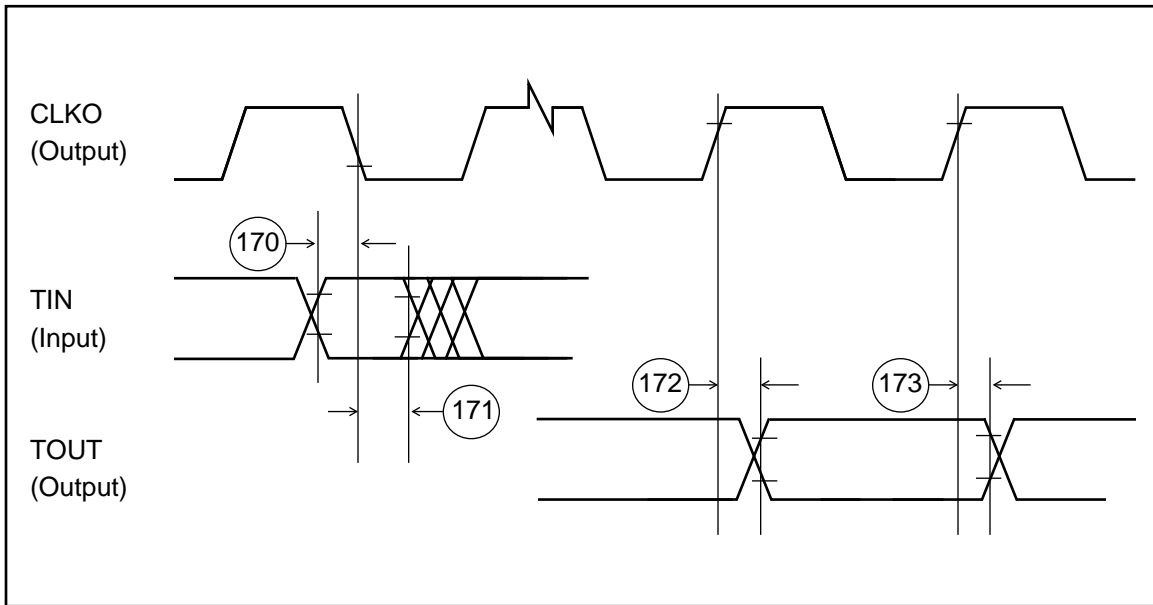

Timer Figure 1. Timer Timing

AC Electrical Characteristics — OnCE Timing

VCC = 5.0 Vdc +/- 10%, TJ = -40° to +125° C, CL = 50 pF + 1 TTL Load).

Num	Characteristic	60 MHz		Unit
		Min	Max	
180	DSCK High to DSO Valid	—	27.6	ns
181	DSI Valid to DSCK Low (Setup)	1	—	ns
182	DSCK Low to DSI Invalid (Hold)	0.9	—	ns
183	DSCK High (See note 1)	2Tc	—	ns
184	DSCK Low (See note 1)	2Tc	—	ns
185	DSCK Cycle Time (See note 1)	4Tc	—	ns
186	CLKO High to OS0-OS1 Valid		14.5	ns
187	CLKO High to OS0-OS1 Invalid	—	—	ns
188	Last DSCK High to OS0-OS1(See note 2) Last DSCK High to \overline{ACK} Active (data)(See note 2) Last DSCK High to \overline{ACK} Active (command)(See note 2)	10T+Td+14.5 10T+Td+13.5 21T+Td+13.5	— —	ns
189	DSO (\overline{ACK}) Asserted to OS0-OS1 Three-state	—	TBD	ns
190	DSO (\overline{ACK}) Asserted to First DSCK High	3Tc	—	ns
191	DSO (\overline{ACK}) Width Asserted: a. when entering debug mode b. when acknowledging command/data transfer	8T+1.1 9T+1.1	8T+4.1 9T+4.1	ns ns
192	Last DSCK Low of Read Register to First DSCK High of Next Command	6Tc	—	ns
193	DSCK High to DSO Invalid (See note 2)	10.9	—	ns
194	\overline{DR} asserted to DSO (\overline{ACK}) Asserted	11T+19.5	—	ns

NOTES:

1. 45%-55% duty cycle
2. Td=DSCK High (183)

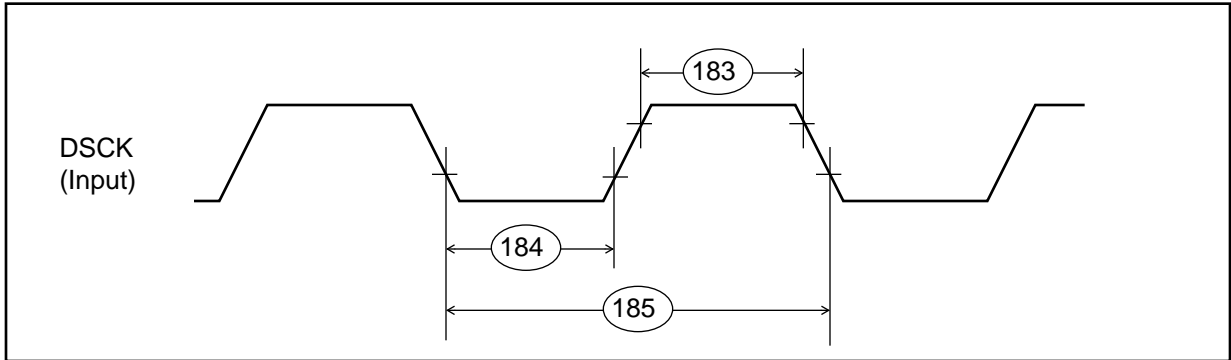

OnCE Figure 1. OnCE Serial Clock Timing

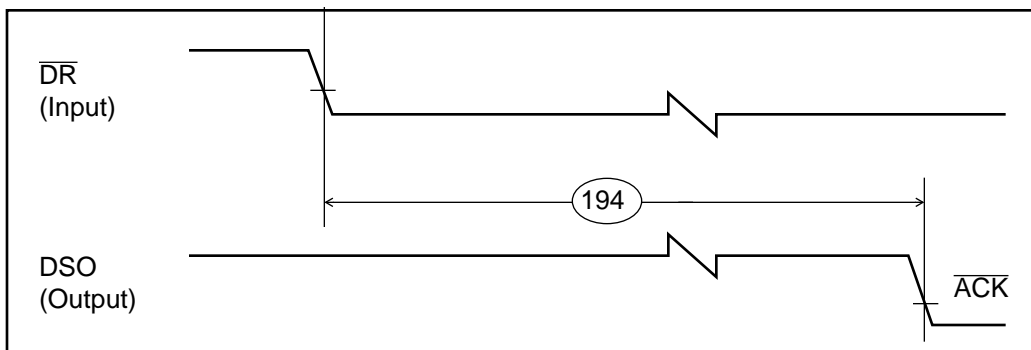

OnCE Figure 2. OnCE Acknowledge Timing

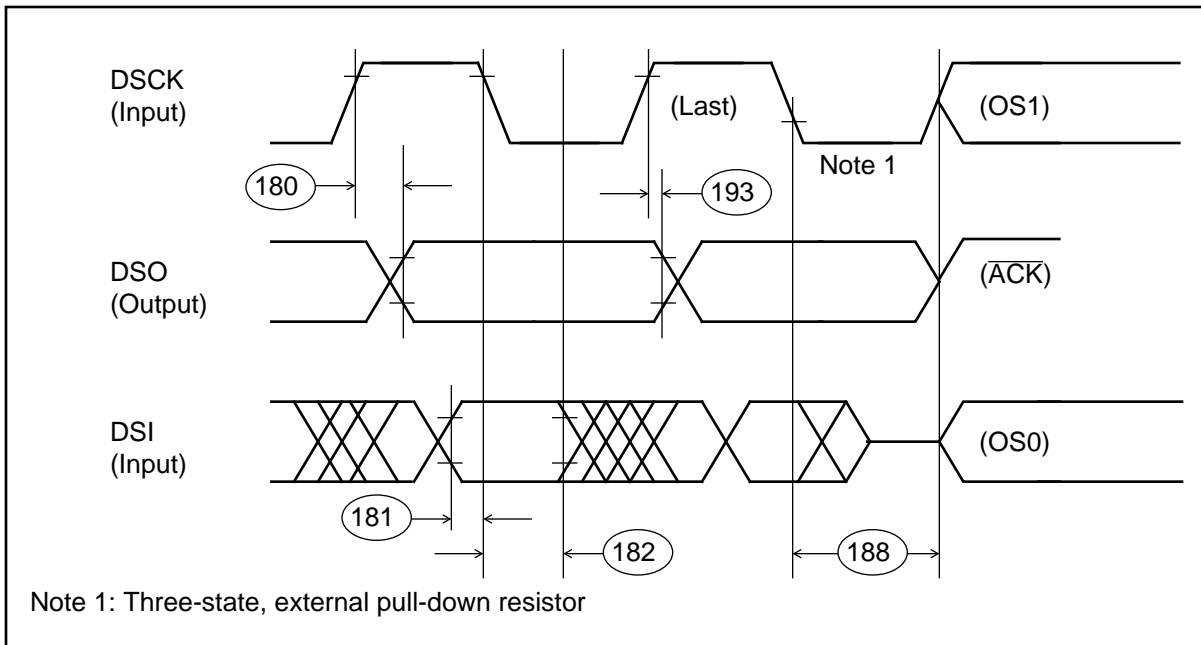

OnCE Figure 3. OnCE Data I/O To Status Timing

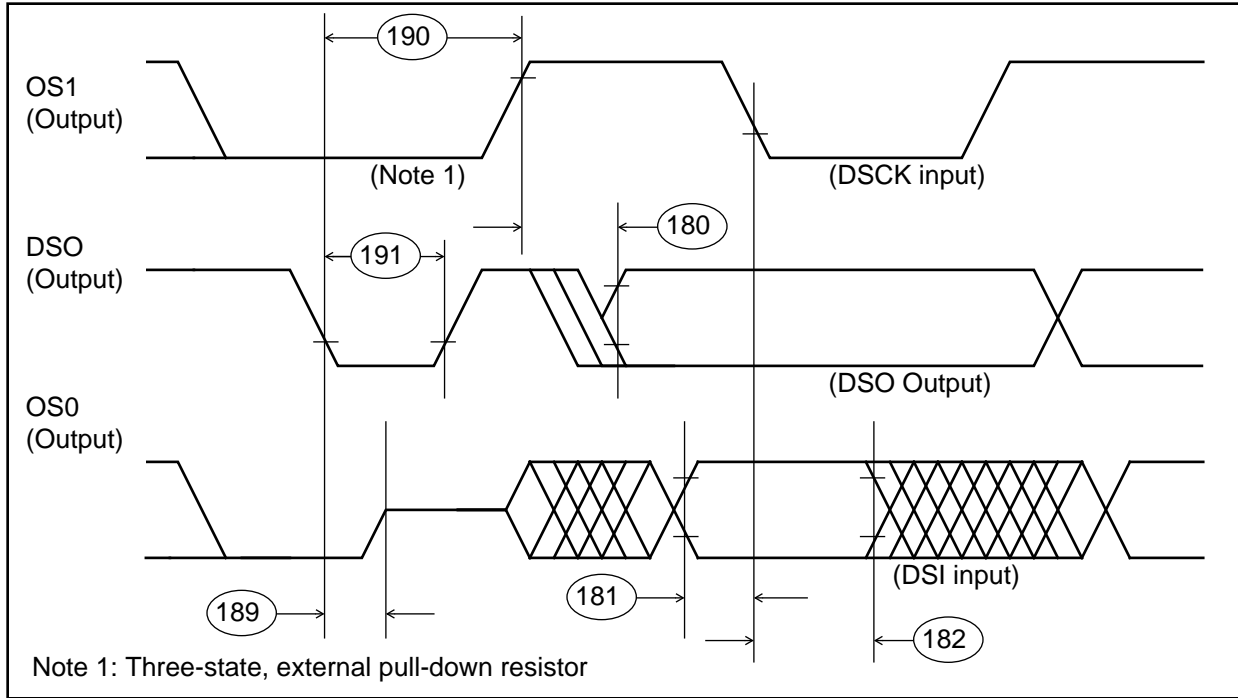

OnCE Figure 4. OnCE Data I/O To Status Timing

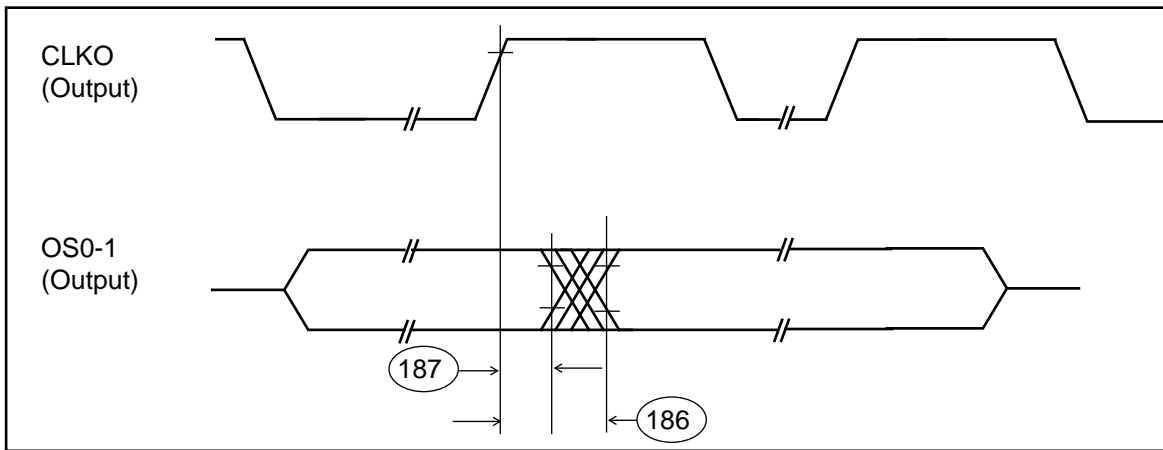

OnCE Figure 5. OnCE CLK To Status Timing

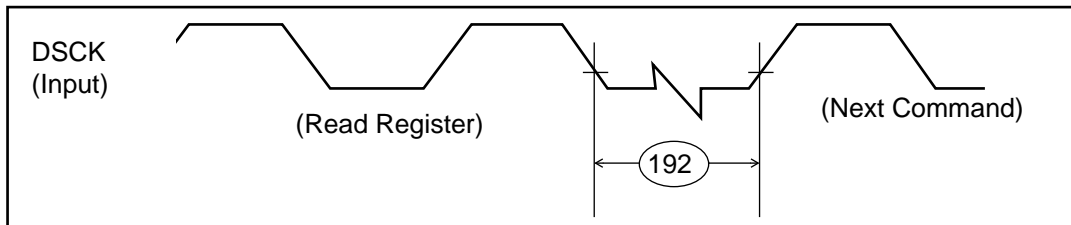

OnCE Figure 6. OnCE DSCK Next Command After Read Register Timing

AC Electrical Characteristics — General Purpose I/O (GPIO) Timing

(VCC = 5.0 Vdc +/- 10%, TJ = -40 to +125 °C, CL = 50 pF + 1 TTL Load).

Num	Characteristic	60 MHz		Unit
		Min	Max	
201	CLKO Edge to GPIO Out Valid (GPIO Out Delay Time)	TBD	TBD	ns
202	CLKO Edge to GPIO Out Not Valid (GPIO Out Hold Time)	TBD	TBD	ns
203	GPIO In Valid to CLKO Edge (GPIO In Set-upTime)	TBD	TBD	ns
204	CLKO Edge to GPIO In Not Valid (GPIO In Hold Time)	TBD	TBD	ns

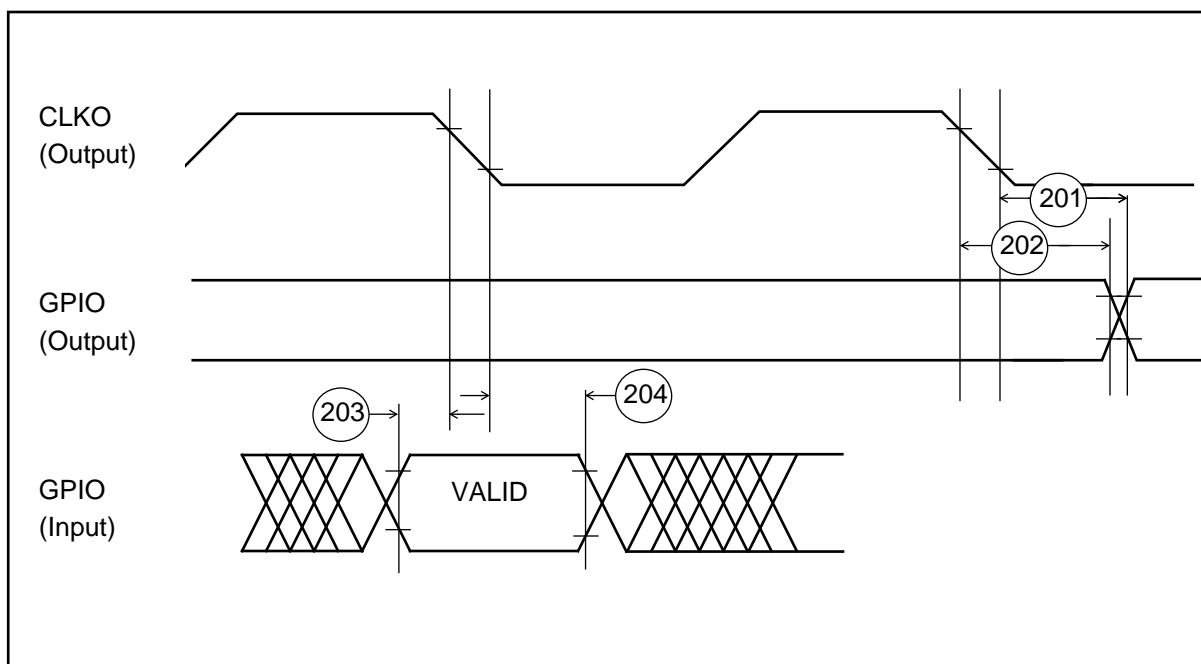

GPIO Figure 1. GPIO Timing

MOTOROLA

SEMICONDUCTOR

TECHNICAL DATA

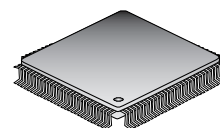
*Advance Information***16-bit General Purpose
Digital Signal Processor****DSP56166ROM****Ceramic Quad Flat Pack (CQFP)**Available in a 112 pin, small footprint,
surface mount package.

The DSP56166ROM is the second member of Motorola's DSP56100 family of HCMOS, low power, 16-bit general purpose Digital Signal Processors (DSP). Designed primarily for speech coding and digital communications, the DSP56166ROM has a built-in $\Sigma\Delta$ codec and phase locked loop (PLL). This MPU-style DSP also contains, memories, peripherals, and provides a cost effective, high performance solution to many DSP applications. On-Chip Emulation (OnCE™) circuitry provides convenient and inexpensive debug facilities normally available only through expensive external hardware. Development costs are reduced and in-field testing is greatly simplified by using the OnCE. The DSP56166 ROM based part contains a 12K ROM (8K x 16 program ROM and 4K x 16 data ROM).

The Central Processing Unit (CPU) consists of three execution units operating in parallel allowing up to six operations to occur in an instruction cycle. This parallelism greatly increases the effective processing speed of the DSP56166ROM. The MPU-style programming model and instruction set allow straightforward generation of efficient, compact code. The basic architectures and development tools of the DSP56100, DSP56000, and DSP96000 families are so similar that learning to design and program one greatly reduces the time needed to learn the others.

DSP56166ROM Feature List**DSP56100 Family Features**

- | | |
|---|--|
| <ul style="list-style-type: none"> • Up to 30 Million Instructions per Second (MIPS) at 60 MHz.— 33.3 ns Instruction cycle • Single-cycle 16 x 16-bit parallel Multiply-Accumulate • 2 x 40-bit accumulators with extension byte • Fractional and integer arithmetic with support for multiprecision arithmetic • Highly parallel instruction set with unique DSP addressing modes • Nested hardware DO loops including infinite loops and DO zero loop • Two instruction LMS adaptive filter loop • Fast auto-return interrupts • Three external interrupt request pins | <ul style="list-style-type: none"> • Three 16-bit internal data and three 16-bit internal address buses • Individual programmable wait states on the external bus for program, data, and peripheral memory spaces • Off-chip memory-mapped peripheral space with programmable access time and separate peripheral enable pin • On-chip memory-mapped peripheral registers • Low Power Wait and Stop modes • On-Chip Emulation (OnCE) for unobtrusive, processor speed independent debugging • Operating frequency down to DC • 5V single power supply • Low power (HCMOS) |
|---|--|

DSP56166ROM On-chip Resources

- | | |
|---|---|
| <ul style="list-style-type: none"> • 4K x 16 on-chip data RAM • 4K x 16 on-chip data ROM • 256 x 16 on-chip program RAM • 8K x 16 on-chip program ROM • One external 16-bit address bus • One external 16-bit data bus • On-chip $\Sigma\Delta$ voice band codec (A/D-D/A) <ul style="list-style-type: none"> – Internal voltage reference (2/5 of positive power supply) | <ul style="list-style-type: none"> – No off-chip components required • 25 general purpose I/O pins • On-chip, programmable PLL • Byte-wide Host Interface with DMA support • Two independent reduced synchronous serial interfaces • One 16-bit timer • 112 pin quad flat pack packaging |
|---|---|

Operational Differences Of The ROM Based Part From The RAM Based Part

- | | |
|---|--|
| <ul style="list-style-type: none"> • XROM can only be accessed during a single read or the first read of a dual parallel read instruction (see note on back. • No bootstrap ROM | <ul style="list-style-type: none"> • Reset mode 1 vectors to P:\$0100 • PROM area P:\$2080 — P:\$20FF is reserved and should not be programmed or accessed by the user |
|---|--|

This document contains information on a new product. Specifications and information herein are subject to change without notice.

**MOTOROLA**



OnCE is a trademark of Motorola, Inc.

All product and brand names appearing herein are trademarks or registered trademarks of their respective holders.

Motorola reserves the right to make changes without further notice to any products herein. Motorola makes no warranty, representation or guarantee regarding the suitability of its products for any particular purpose, nor does Motorola assume any liability arising out of the application or use of any product or circuit, and specifically disclaims any and all liability, including without limitation consequential or incidental damages. "Typical" parameters can and do vary in different applications. All operating parameters, including "Typical", must be validated for each customer application by customer's technical experts. Motorola does not convey any license under its patent rights nor the rights of others. Motorola products are not designed, intended, or authorized for use as components in systems intended for surgical implant into the body, or other applications intended to support or sustain life, or for any other application in which the failure of the Motorola product could create a situation where personal injury or death may occur. Should Buyer purchase or use Motorola products for any such unintended or unauthorized application, Buyer shall indemnify and hold Motorola and its officers, employees, subsidiaries, affiliates, and distributors harmless against all claims, costs, damages, and expenses, and reasonable attorney fees arising out of, directly or indirectly, any claim of personal injury or death associated with such unintended or unauthorized use, even if such claim alleges that Motorola was negligent regarding the design or manufacture of the part.

Motorola and **b** are registered trademarks of Motorola, Inc.
Motorola, Inc. is an Equal Opportunity/Affirmative Action Employer.

Literature Distribution Centers

USA: Motorola Literature Distribution; P.O. Box 20912; Phoenix, Arizona 85036.

EUROPE: Motorola Ltd.; European Literature Centre; 88 Tanners Drive, Blakelands, Milton Keynes, MK14 5BP, United Kingdom.

JAPAN: Nippon Motorola Ltd.; 4-32-1, Nishi-Gotanda, Shinagawa-ku, Tokyo 141 Japan.

ASIA-PACIFIC: Motorola Semiconductors H.K. Ltd.; Silicon Harbor Center, No. 2 Dai King Street, Tai Po Industrial Estate, Tai Po, N.T., Hong Kong.



MOTOROLA

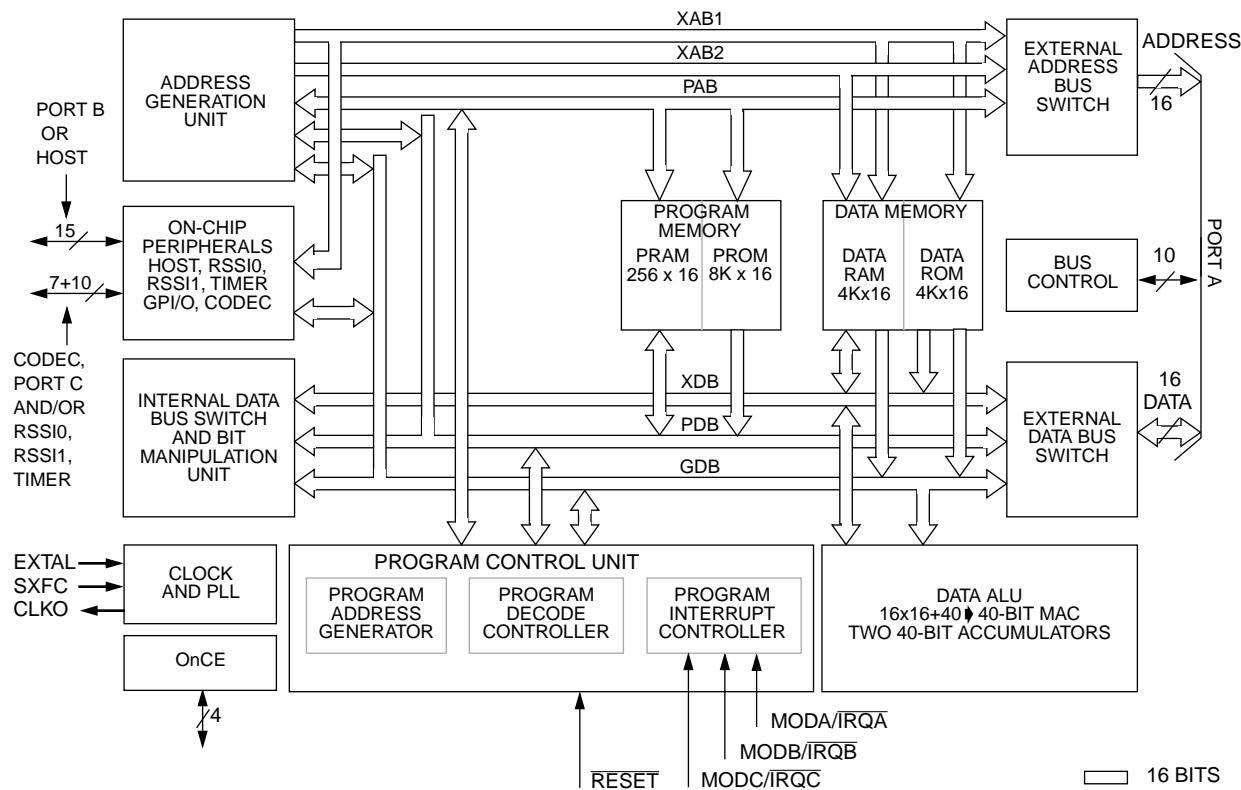

DSP56166ROM Block Diagram

In the USA:

For technical assistance call:
 DSP Applications Helpline (512) 891-3230

For availability and literature call your local Motorola Sales Office or Authorized Distributor.

For free application software and information call the Dr. BuB electronic bulletin board:
 9600/4800/2400/1200/300 baud
 (512) 891-3771
 (8 data bits, no parity, 1 stop)

In Europe, Japan and Asia Pacific

Contact your regional sales office or Motorola distributor.

Note: Since the on-chip XROM is only connected to the XAB1 address bus (see the block diagram above), the data located in this ROM is only accessible by the **first** read of a single read instruction or the **first** read of a dual parallel read instruction. Therefore, during development using the RAM based part, the data to be mapped in the on-chip XROM on the ROM based part **should not** be accessed with a **second** read during a dual parallel read instruction.

Motorola reserves the right to make changes without further notice to any products herein. Motorola makes no warranty, representation or guarantee regarding the suitability of its products for any particular purpose, nor does Motorola assume any liability arising out of the application or use of any product or circuit, and specifically disclaims any and all liability, including without limitation consequential or incidental damages. "Typical" parameters can and do vary in different applications. All operating parameters, including "Typicals" must be validated for each customer application by customer's technical experts. Motorola does not convey any license under its patent rights nor the rights of others. Motorola products are not designed, intended, or authorized for use as components in systems intended for surgical implant into the body, or other applications intended to support or sustain life, or for any other application in which the failure of the Motorola product could create a situation where personal injury or death may occur. Should Buyer purchase or use Motorola products for any such unintended or unauthorized application, Buyer shall indemnify and hold Motorola and its officers, employees, subsidiaries, affiliates, and distributors harmless against all claims, costs, damages, and expenses, and reasonable attorney fees arising out of, directly or indirectly, any claim of personal injury or death associated with such unintended or unauthorized use, even if such claim alleges that Motorola was negligent regarding the design or manufacture of the part. Motorola and M are registered trademarks of Motorola, Inc. Motorola, Inc. is an Equal Opportunity/Affirmative Action Employer.

Literature Distribution Centers:

USA: Motorola Literature Distribution; P.O. Box 20912; Phoenix, Arizona 85036.

EUROPE: Motorola Ltd.; European Literature Center; 88 Tanners Drive, Blakelands, Milton Keynes, MK14 5BP, England.

JAPAN: Nippon Motorola Ltd.; 4-32-1, Nishi-Gotanda, Shinagawa-ku, Tokyo 141 Japan.

ASIA-PACIFIC: Motorola Semiconductors H.K. Ltd.; Silicon Harbor Center, No. 2 Dai King Street, Tai Po Industrial Estate, Tai Po, N.T., Hong Kong.



MOTOROLA

Corrections to the DSP56166 Data Sheet Dated 6/15/93

1. Remove the entry for the BIAS pin (page 9 of the 6/15/93 data sheet)



LittleDiode supplies new, hard to find or obsolete electronic components and semiconductors all over the world.

With over two million different components listed you are sure to find the part you need.

Feel free to visit us today at our online store:

LittleDiode.com

Looking forward to providing you with the best possible service.