

## HIGH VOLTAGE FAST-SWITCHING NPN POWER TRANSISTOR

- SGS-THOMSON PREFERRED SALESTYPE
- HIGH VOLTAGE CAPABILITY
- LOW SPREAD OF DYNAMIC PARAMETERS
- MINIMUM LOT-TO-LOT SPREAD FOR RELIABLE OPERATION
- VERY HIGH SWITCHING SPEED
- LARGE RBSOA
- INTEGRATED ANTIPARALLEL COLLECTOR-EMITTER DIODE

### APPLICATIONS

- ELECTRONIC TRANSFORMERS FOR HALOGEN LAMPS
- ELECTRONIC BALLASTS FOR FLUORESCENT LIGHTING
- SWITCH MODE POWER SUPPLIES

### DESCRIPTION

The BUL381D is manufactured using high voltage Multi Epitaxial Planar technology for high switching speeds and high voltage capability. The BUL series is designed for use in lighting applications and low cost switch-mode power supplies.

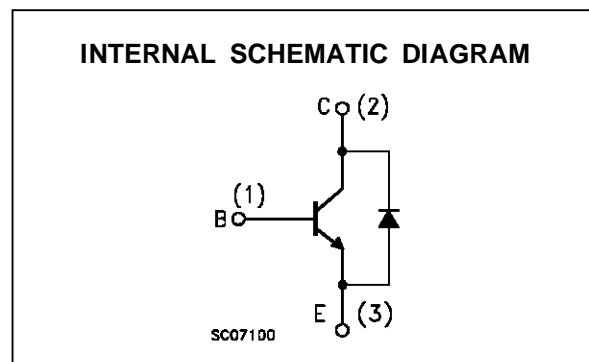
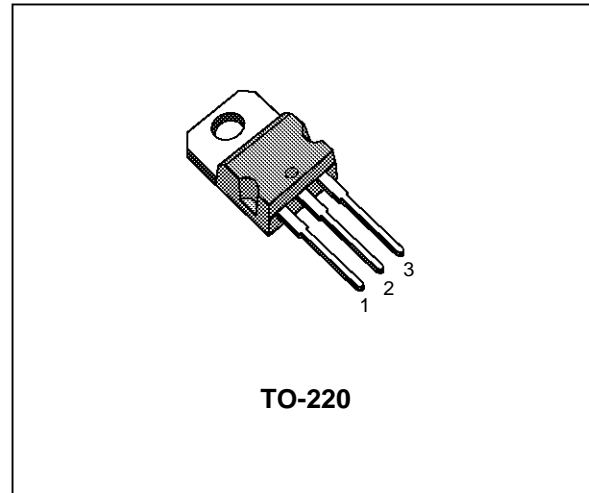

### ABSOLUTE MAXIMUM RATINGS

Symbol	Parameter	Value	Unit
$V_{CES}$	Collector-Emitter Voltage ( $V_{BE} = 0$ )	800	V
$V_{CEO}$	Collector-Emitter Voltage ( $I_B = 0$ )	400	V
$V_{EBO}$	Emitter-Base Voltage ( $I_C = 0$ )	9	V
$I_C$	Collector Current	5	A
$I_{CM}$	Collector Peak Current ( $t_p < 5$ ms)	8	A
$I_B$	Base Current	2	A
$I_{BM}$	Base Peak Current ( $t_p < 5$ ms)	4	A
$P_{tot}$	Total Dissipation at $T_c = 25$ °C	70	W
$T_{stg}$	Storage Temperature Range	-65 to 150	°C
$T_j$	Max. Operating Junction Temperature	150	°C

# BUL381D

## THERMAL DATA

$R_{thj-case}$	Thermal Resistance Junction-Case	Max	1.78	$^{\circ}C/W$
$R_{thj-amb}$	Thermal Resistance Junction-Ambient	Max	62.5	$^{\circ}C/W$

## ELECTRICAL CHARACTERISTICS ( $T_{case} = 25^{\circ}C$ unless otherwise specified)

Symbol	Parameter	Test Conditions	Min.	Typ.	Max.	Unit
$I_{CES}$	Collector Cut-off Current ( $V_{BE} = 0$ )	$V_{CE} = 800 V$ $V_{CE} = 800 V \quad T_j = 125^{\circ}C$			100 500	$\mu A$ $\mu A$
$I_{CEO}$	Collector Cut-off Current ( $I_B = 0$ )	$V_{CE} = 400 V$			250	$\mu A$
$V_{CEO(sus)}$	Collector-Emitter Sustaining Voltage	$I_C = 100 mA \quad L = 25 mH$	400			V
$V_{EBO}$	Emitter-Base Voltage ( $I_C = 0$ )	$I_E = 10 mA$	9			V
$V_{CE(sat)*}$	Collector-Emitter Saturation Voltage	$I_C = 1 A \quad I_B = 0.2 A$ $I_C = 2 A \quad I_B = 0.4 A$ $I_C = 3 A \quad I_B = 0.75 A$			0.5 0.7 1.1	V V V
$V_{BE(sat)*}$	Base-Emitter Saturation Voltage	$I_C = 1 A \quad I_B = 0.2 A$ $I_C = 2 A \quad I_B = 0.4 A$			1.1 1.2	V V
$h_{FE*}$	DC Current Gain	$I_C = 2 A \quad V_{CE} = 5 V$ $I_C = 10 mA \quad V_{CE} = 5 V$	8 10			
$t_s$ $t_f$	RESISTIVE LOAD Storage Time Fall Time	$I_C = 2 A \quad V_{CC} = 250 V$ $I_{B1} = 0.4 A \quad I_{B2} = -0.4 V$ $t_p = 30 \mu s$	1.5		2.5 0.8	$\mu s$ ns
$t_s$ $t_f$	INDUCTIVE LOAD Storage Time Fall Time	$I_C = 2 A \quad I_{B1} = 0.4 A$ $V_{BE(off)} = -5 V \quad R_{BB} = 0 \Omega$ $V_{CL} = 250 V \quad L = 200 \mu H$ $T_j = 125^{\circ}C$		1.3 100		$\mu s$ ns
$V_f$	Diode Forward Voltage	$I_C = 2 A$			2.5	V

\* Pulsed: Pulse duration = 300  $\mu s$ , duty cycle 1.5 %

## Safe Operating Areas

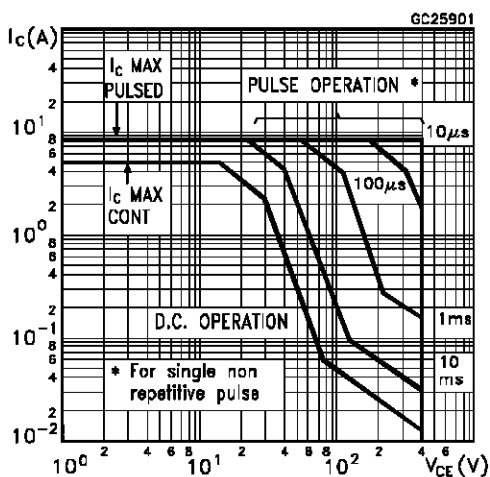

## Derating Curves

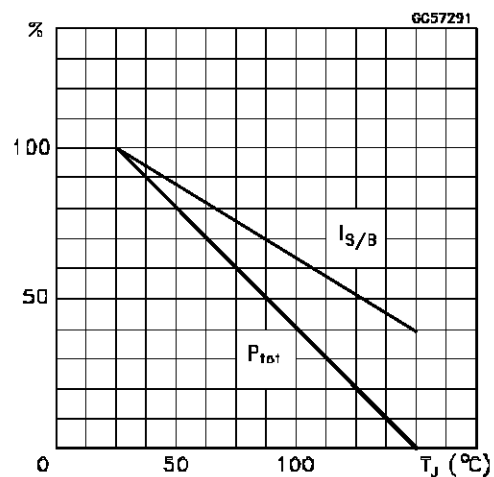

DC Current Gain

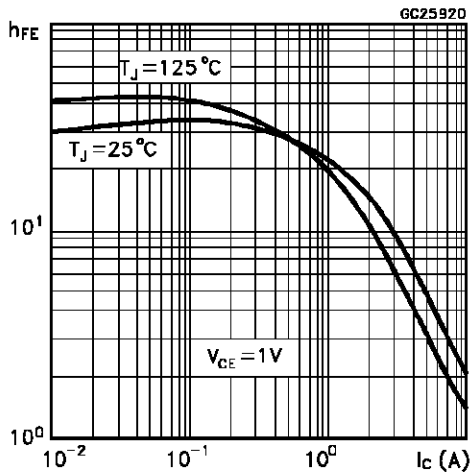

DC Current Gain

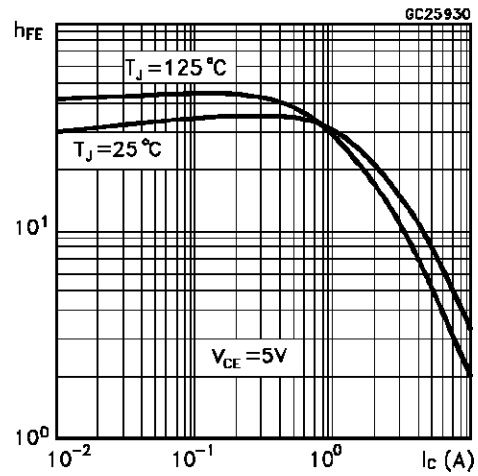

Collector Emitter Saturation Voltage

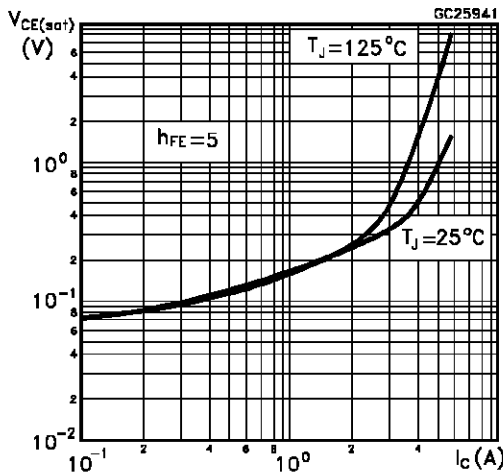

Base Emitter Saturation Voltage

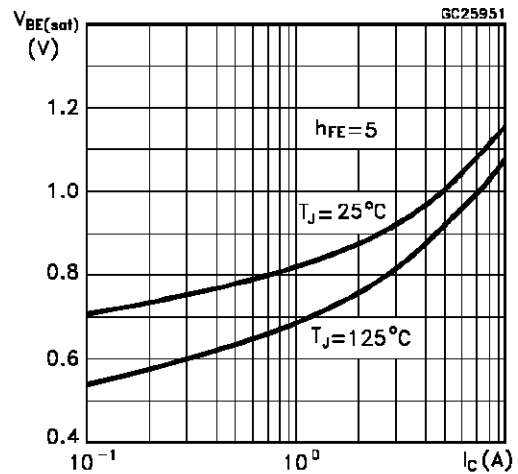

Inductive Fall Time

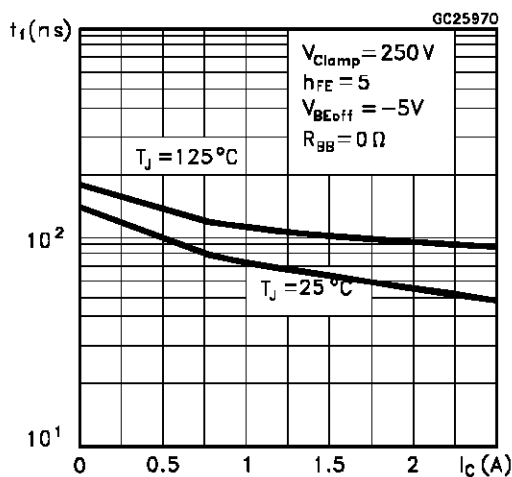

Inductive Storage Time

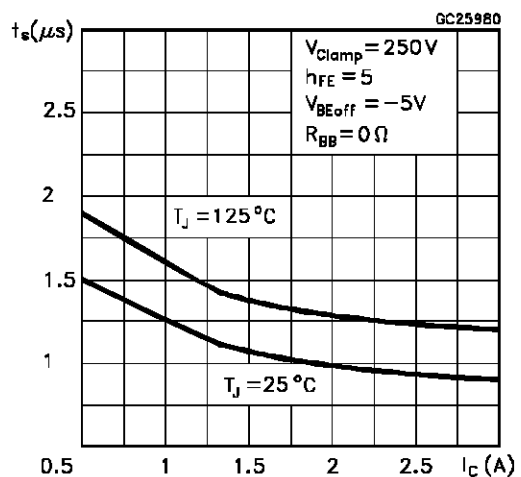

Reverse Biased SOA

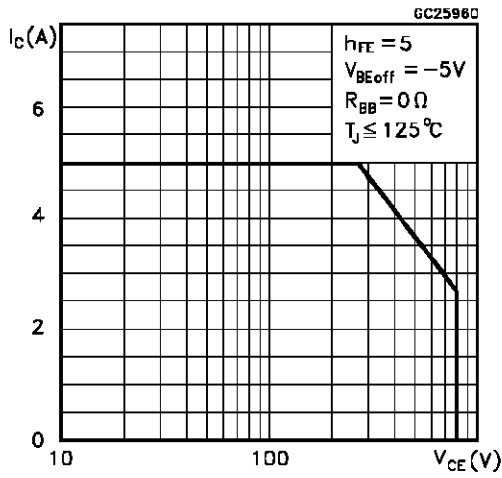

Resistive Load Switching Test Circuit

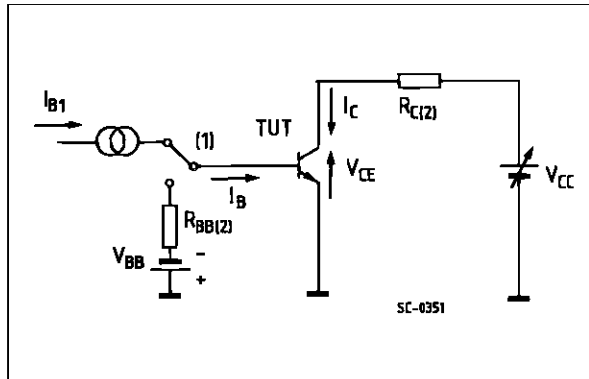

- (1) Fast electronic switch
- (2) Non-inductive Resistor

RBSOA and Inductive Load Switching Test Circuit

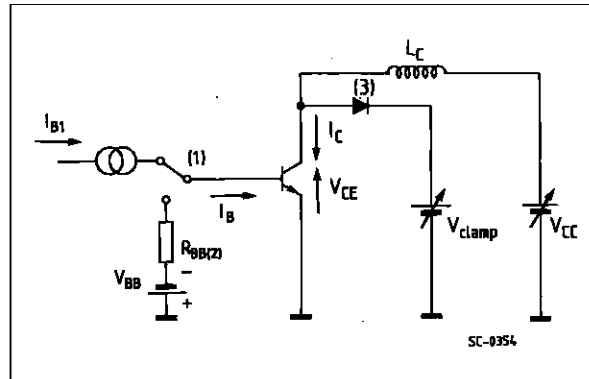

- (1) Fast electronic switch
- (2) Non-inductive Resistor
- (3) Fast recovery rectifier

**TO-220 MECHANICAL DATA**

DIM.	mm			inch		
	MIN.	TYP.	MAX.	MIN.	TYP.	MAX.
A	4.40		4.60	0.173		0.181
C	1.23		1.32	0.048		0.051
D	2.40		2.72	0.094		0.107
D1		1.27			0.050	
E	0.49		0.70	0.019		0.027
F	0.61		0.88	0.024		0.034
F1	1.14		1.70	0.044		0.067
F2	1.14		1.70	0.044		0.067
G	4.95		5.15	0.194		0.203
G1	2.4		2.7	0.094		0.106
H2	10.0		10.40	0.393		0.409
L2		16.4			0.645	
L4	13.0		14.0	0.511		0.551
L5	2.65		2.95	0.104		0.116
L6	15.25		15.75	0.600		0.620
L7	6.2		6.6	0.244		0.260
L9	3.5		3.93	0.137		0.154
DIA.	3.75		3.85	0.147		0.151

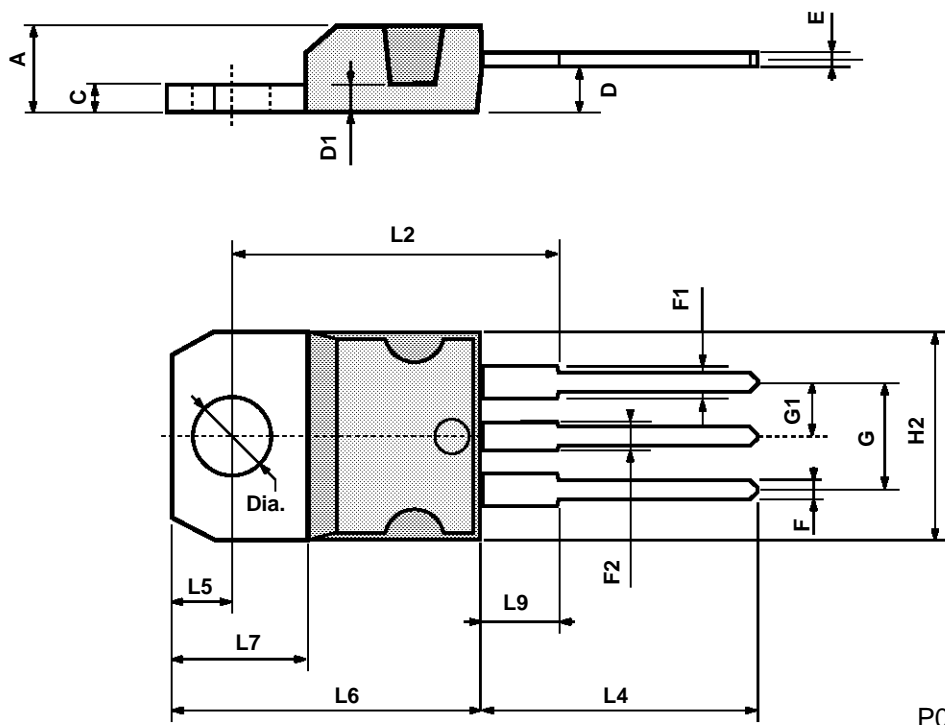

Information furnished is believed to be accurate and reliable. However, SGS-THOMSON Microelectronics assumes no responsibility for the consequences of use of such information nor for any infringement of patents or other rights of third parties which may result from its use. No license is granted by implication or otherwise under any patent or patent rights of SGS-THOMSON Microelectronics. Specifications mentioned in this publication are subject to change without notice. This publication supersedes and replaces all information previously supplied. SGS-THOMSON Microelectronics products are not authorized for use as critical components in life support devices or systems without express written approval of SGS-THOMSON Microelectronics.

© 1994 SGS-THOMSON Microelectronics - All Rights Reserved

SGS-THOMSON Microelectronics GROUP OF COMPANIES  
Australia - Brazil - France - Germany - Hong Kong - Italy - Japan - Korea - Malaysia - Malta - Morocco - The Netherlands -  
Singapore - Spain - Sweden - Switzerland - Taiwan - Thailand - United Kingdom - U.S.A