



2K x 8 Dual-Port Static RAM

Features

- True Dual-Ported memory cells which allow simultaneous reads of the same memory location
- 2K x 8 organization
- 0.65-micron CMOS for optimum speed/power
- High-speed access: 15 ns
- Low operating power: $I_{CC} = 110$ mA (max.)
- Fully asynchronous operation
- Automatic power-down
- Master CY7C132/CY7C136 easily expands data bus width to 16 or more bits using slave CY7C142/CY7C146
- BUSY output flag on CY7C132/CY7C136; BUSY input on CY7C142/CY7C146
- INT flag for port-to-port communication (52-pin PLCC/PQFP versions)
- Available in 48-pin DIP (CY7C132/142), 52-pin PLCC and 52-pin TQFP (CY7C136/146)

Functional Description

The CY7C132/CY7C136/CY7C142 and CY7C146 are high-speed CMOS 2K by 8 dual-port static RAMs. Two ports are provided to permit independent access to any location in memory. The CY7C132/ CY7C136 can be utilized as either a standalone 8-bit dual-port static RAM or as a MASTER dual-port RAM in conjunction with the CY7C142/CY7C146 SLAVE dual-port device in systems requiring 16-bit or greater word widths. It is the solution to applications requiring shared or buffered data such as cache memory for DSP, bit-slice, or multiprocessor designs.

Each port has independent control pins; chip enable (\overline{CE}), write enable (R/W), and output enable (\overline{OE}). BUSY flags are provided on each port. In addition, an interrupt flag (INT) is provided on each port of the 52-pin PLCC version. BUSY signals that the port is trying to access the same location currently being accessed by the other port. On the PLCC version, INT is an interrupt flag indicating that data has been placed in a unique location (7FF for the left port and 7FE for the right port).

An automatic power-down feature is controlled independently on each port by the chip enable (\overline{CE}) pins.

The CY7C132/CY7C142 are available in 48-pin DIP. The CY7C136/CY7C146 are available in 52-pin PLCC and PQFP.

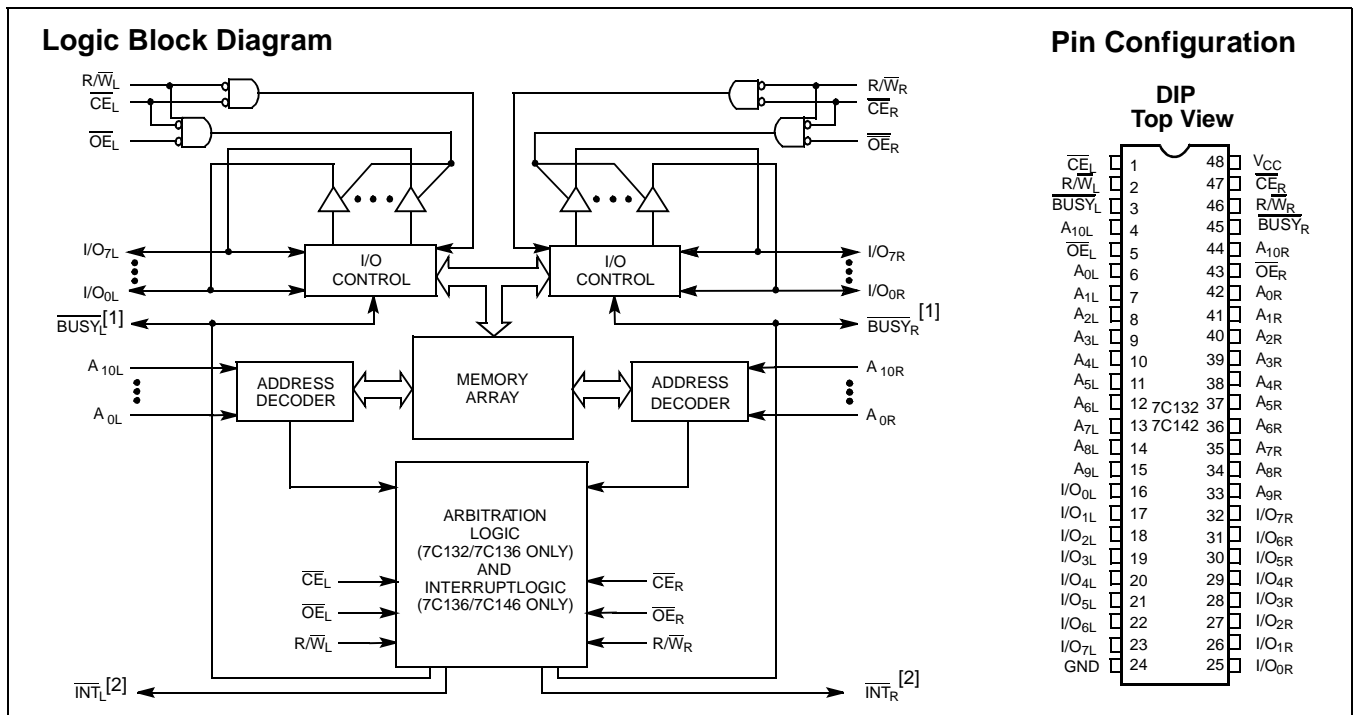

Notes:

1. CY7C132/CY7C136 (Master): BUSY is open drain output and requires pull-up resistor. CY7C142/CY7C146 (Slave): BUSY is input.
2. Open drain outputs; pull-up resistor required.

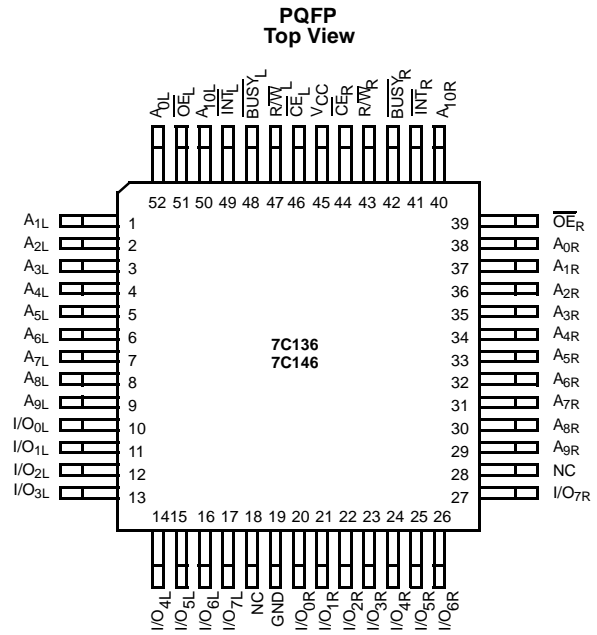
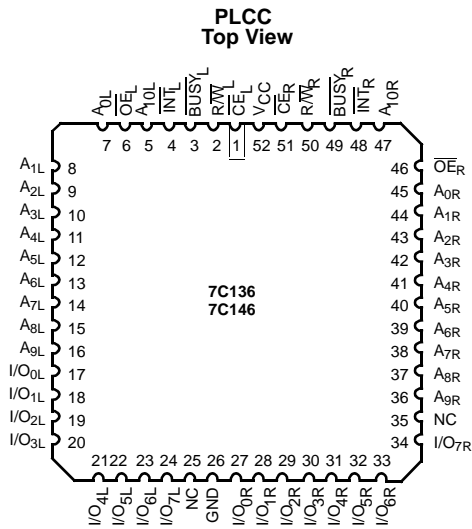
Pin Configurations

Selection Guide

		7C132-25 ^[3] 7C136-25 7C142-25 7C146-25	7C132-30 7C136-30 7C142-30 7C146-30	7C132-35 7C136-35 7C142-35 7C146-35	7C132-45 7C136-45 7C142-45 7C146-45	7C132-55 7C136-55 7C142-55 7C146-55	Unit	
Maximum Access Time		15	25	30	35	45	55	ns
Maximum Operating Current	Com'l/Ind	190	170	170	120	120	110	mA
Maximum Operating Current	Military				170	170	120	mA
Maximum Standby Current	Com'l/Ind	75	65	65	45	45	35	mA
	Military				65	65	45	

Shaded area contains preliminary information.

Note:

- 15 and 25-ns version available in PQFP and PLCC packages only.



Maximum Ratings

(Above which the useful life may be impaired. For user guidelines, not tested.)

- Storage Temperature -65°C to +150°C
- Ambient Temperature with Power Applied..... -55°C to +125°C
- Supply Voltage to Ground Potential (Pin 48 to Pin 24)..... -0.5V to +7.0V
- DC Voltage Applied to Outputs in High-Z State -0.5V to +7.0V

- DC Input Voltage -3.5V to +7.0V
- Output Current into Outputs (LOW)..... 20 mA
- Static Discharge Voltage..... > 2001V (per MIL-STD-883, Method 3015)
- Latch-up Current..... > 200 mA

Operating Range

Range	Ambient Temperature	V _{CC}
Commercial	0°C to +70°C	5V ± 10%
Industrial	-40°C to +85°C	5V ± 10%
Military ^[4]	-55°C to +125°C	5V ± 10%

Electrical Characteristics Over the Operating Range^[5]

Parameter	Description	Test Conditions	7C136-15 ^[3]		7C132-30 ^[3] 7C136-25,30 7C142-30 7C146-25,30		7C132-35,45 7C136-35,45 7C142-35,45 7C146-35,45		7C132-55 7C136-55 7C142-55 7C146-55		Unit
			Min.	Max.	Min.	Max.	Min.	Max.	Min.	Max.	
V _{OH}	Output HIGH voltage	V _{CC} = Min., I _{OH} = -4.0 mA	2.4		2.4		2.4		2.4		V
V _{OL}	Output LOW voltage	I _{OL} = 4.0 mA		0.4		0.4		0.4		0.4	V
		I _{OL} = 16.0 mA ^[6]		0.5		0.5		0.5		0.5	
V _{IH}	Input HIGH voltage		2.2		2.2		2.2		2.2		V
V _{IL}	Input LOW voltage			0.8		0.8		0.8		0.8	V
I _{IX}	Input load current	GND ≤ V _I ≤ V _{CC}	-5	+5	-5	+5	-5	+5	-5	+5	µA
I _{OZ}	Output leakage current	GND ≤ V _O ≤ V _{CC} , Output Disabled	-5	+5	-5	+5	-5	+5	-5	+5	µA
I _{OS}	Output short circuit current ^[7]	V _{CC} = Max., V _{OUT} = GND		-350		-350		-350		-350	mA
I _{CC}	V _{CC} Operating Supply Current	CE = V _{IL} , Outputs Open, f = f _{MAX} ^[8]	Com'l	190		170		120		110	mA
			Mil					170		120	
I _{SB1}	Standby current both ports, TTL Inputs	CE _L and CE _R ≥ V _{IH} , f = f _{MAX} ^[8]	Com'l	75		65		45		35	mA
			Mil					65		45	
I _{SB2}	Standby Current One Port, TTL Inputs	CE _L or CE _R ≥ V _{IH} , Active Port Outputs Open, f = f _{MAX} ^[8]	Com'l	135		115		90		75	mA
			Mil					115		90	
I _{SB3}	Standby Current Both Ports, CMOS Inputs	Both Ports CE _L and CE _R ≥ V _{CC} - 0.2V, V _{IN} ≥ V _{CC} - 0.2V or V _{IN} ≤ 0.2V, f = 0	Com'l	15		15		15		15	mA
			Mil					15		15	
I _{SB4}	Standby Current One Port, CMOS Inputs	One Port CE _L or CE _R > V _{CC} - 0.2V, V _{IN} > V _{CC} - 0.2V or V _{IN} < 0.2V, Active Port Outputs Open, f = f _{MAX} ^[8]	Com'l	125		105		85		70	mA
			Mil					105		85	

Capacitance^[9]

Parameter	Description	Test Conditions	Max.	Unit
C _{IN}	Input Capacitance	T _A = 25°C, f = 1 MHz,	15	pF
C _{OUT}	Output Capacitance	V _{CC} = 5.0V	10	pF

Shaded area contains preliminary information.

Notes:

4. T_A is the "instant on" case temperature.
5. See the last page of this specification for Group A subgroup testing information.
6. BUSY and INT pins only.
7. Duration of the short circuit should not exceed 30 seconds.
8. At f = f_{MAX}, address and data inputs are cycling at the maximum frequency of read cycle of 1/t_{rc} and using AC Test Waveforms input levels of GND to 3V.
9. This parameter is guaranteed but not tested.

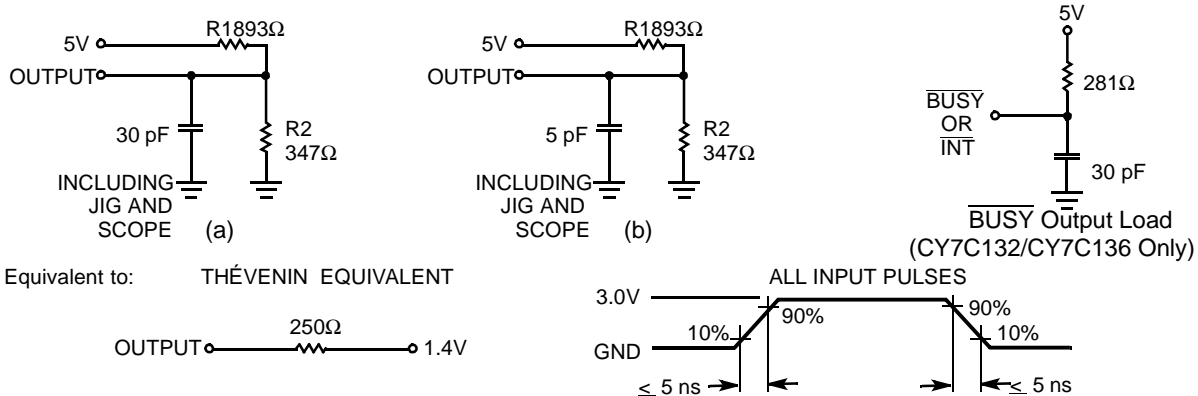
AC Test Loads and Waveforms

Switching Characteristics Over the Operating Range (Speeds -15, -25, -30) [5, 10]

Parameter	Description	7C136-15 ^[3] 7C146-15		7C132-25 ^[3] 7C136-25 7C142-25 7C146-25		7C132-30 7C136-30 7C142-30 7C146-30		Unit
		Min.	Max.	Min.	Max.	Min.	Max.	
Read Cycle								
t _{RC}	Read Cycle Time	15		25		30		ns
t _{AA}	Address to Data Valid ^[11]		15		25		30	ns
t _{OHA}	Data Hold from Address Change	0		0		0		ns
t _{ACE}	CE LOW to Data Valid ^[11]		15		25		30	ns
t _{DOE}	OE LOW to Data Valid ^[11]		10		15		20	ns
t _{LZOE}	OE LOW to Low Z ^[9, 12]	3		3		3		ns
t _{HZOE}	OE HIGH to High Z ^[9, 12, 13]		10		15		15	ns
t _{LZCE}	CE LOW to Low Z ^[9, 12]	3		5		5		ns
t _{HZCE}	CE HIGH to High Z ^[9, 12, 13]		10		15		15	ns
t _{PU}	CE LOW to Power-Up ^[9]	0		0		0		ns
t _{PD}	CE HIGH to Power-Down ^[9]		15		25		25	ns
Write Cycle^[14]								
t _{WC}	Write Cycle Time	15		25		30		ns
t _{SCE}	CE LOW to Write End	12		20		25		ns
t _{AW}	Address Set-up to Write End	12		20		25		ns
t _{HA}	Address Hold from Write End	2		2		2		ns
t _{SA}	Address Set-up to Write Start	0		0		0		ns
t _{PWE}	R/W Pulse Width	12		15		25		ns
t _{SD}	Data Set-up to Write End	10		15		15		ns
t _{HD}	Data Hold from Write End	0		0		0		ns
t _{HZWE}	R/W LOW to High Z ^[9]		10		15		15	ns
t _{LZWE}	R/W HIGH to Low Z ^[9]	0		0		0		ns

Shaded areas contain preliminary information.

Notes:

- Test conditions assume signal transition times of 5 ns or less, timing reference levels of 1.5V, input pulse levels of 0 to 3.0V and output loading of the specified I_{OL}/I_{OH}, and 30-pF load capacitance.
- AC test conditions use V_{OH} = 1.6V and V_{OL} = 1.4V.
- At any given temperature and voltage condition for any given device, t_{HZCE} is less than t_{LZCE} and t_{HZOE} is less than t_{LZOE}.
- t_{LZCE}, t_{LZOE}, t_{HZOE}, t_{HZCE}, and t_{HZWE} are tested with C_L = 5pF as in (b) of AC Test Loads. Transition is measured ±500 mV from steady-state voltage.
- The internal write time of the memory is defined by the overlap of CE LOW and R/W LOW. Both signals must be LOW to initiate a write and either signal can terminate a write by going HIGH. The data input setup and hold timing should be referenced to the rising edge of the signal that terminates the write.

Switching Characteristics Over the Operating Range (Speeds -15, -25, -30) (continued)^[5, 10]

Parameter	Description	7C136-15 ^[3] 7C146-15		7C132-25 ^[3] 7C136-25 7C142-25 7C146-25		7C132-30 7C136-30 7C142-30 7C146-30		Unit
		Min.	Max.	Min.	Max.	Min.	Max.	
Busy/Interrupt Timing								
t _{BLA}	BUSY LOW from Address Match		15		20		20	ns
t _{BHA}	BUSY HIGH from Address Mismatch ^[15]		15		20		20	ns
t _{BLC}	BUSY LOW from CE LOW		15		20		20	ns
t _{BHC}	BUSY HIGH from CE HIGH ^[15]		15		20		20	ns
t _{PS}	Port Set Up for Priority	5		5		5		ns
t _{WB}	R/W LOW after BUSY LOW ^[16]	0		0		0		ns
t _{WH}	R/W HIGH after BUSY HIGH	13		20		30		ns
t _{BDD}	BUSY HIGH to Valid Data		15		25		30	ns
t _{DDD}	Write Data Valid to Read Data Valid		Note 17		Note 17		Note 17	ns
t _{WDD}	Write Pulse to Data Delay		Note 17		Note 17		Note 17	ns
Interrupt Timing^[18]								
t _{WINS}	R/W to INTERRUPT Set Time		15		25		25	ns
t _{EINS}	CE to INTERRUPT Set Time		15		25		25	ns
t _{INS}	Address to INTERRUPT Set Time		15		25		25	ns
t _{OINR}	OE to INTERRUPT Reset Time ^[15]		15		25		25	ns
t _{EINR}	CE to INTERRUPT Reset Time ^[15]		15		25		25	ns
t _{INR}	Address to INTERRUPT Reset Time ^[15]		15		25		25	ns

Switching Characteristics Over the Operating Range (Speeds -35, -45, -55) ^[5, 10]

Parameter	Description	7C132-35 7C136-35 7C142-35 7C146-35		7C132-45 7C136-45 7C142-45 7C146-45		7C132-55 7C136-55 7C142-55 7C146-55		Unit
		Min.	Max.	Min.	Max.	Min.	Max.	
Read Cycle								
t _{RC}	Read Cycle Time	35		45		55		ns
t _{AA}	Address to Data Valid ^[11]		35		45		55	ns
t _{OHA}	Data Hold from Address Change	0		0		0		ns
t _{ACE}	CE LOW to Data Valid ^[11]		35		45		55	ns
t _{DOE}	OE LOW to Data Valid ^[11]		20		25		25	ns
t _{LZOE}	OE LOW to Low Z ^[9, 12]	3		3		3		ns
t _{HZOE}	OE HIGH to High Z ^[9, 12, 13]		20		20		25	ns
t _{LZCE}	CE LOW to Low Z ^[9, 12]	5		5		5		ns
t _{HZCE}	CE HIGH to High Z ^[9, 12, 13]		20		20		25	ns
t _{PU}	CE LOW to Power-Up ^[9]	0		0		0		ns
t _{PD}	CE HIGH to Power-Down ^[9]		35		35		35	ns

Notes:

15. These parameters are measured from the input signal changing, until the output pin goes to a high-impedance state.
16. CY7C142/CY7C146 only.
17. A write operation on Port A, where Port A has priority, leaves the data on Port B's outputs undisturbed until one access time after one of the following:
 BUSY on Port B goes HIGH.
 Port B's address toggled.
 CE for Port B is toggled.
 R/W for Port B is toggled during valid read.
18. 52-pin PLCC and PQFP versions only.



Switching Characteristics Over the Operating Range (Speeds -35, -45, -55) (continued)^[5, 10]

Parameter	Description	7C132-35 7C136-35 7C142-35 7C146-35		7C132-45 7C136-45 7C142-45 7C146-45		7C132-55 7C136-55 7C142-55 7C146-55		Unit
		Min.	Max.	Min.	Max.	Min.	Max.	
Write Cycle^[14]								
t _{WC}	Write Cycle Time	35		45		55		ns
t _{SCE}	CE LOW to Write End	30		35		40		ns
t _{AW}	Address Set-up to Write End	30		35		40		ns
t _{HA}	Address Hold from Write End	2		2		2		ns
t _{SA}	Address Set-up to Write Start	0		0		0		ns
t _{PWE}	R/W Pulse Width	25		30		30		ns
t _{SD}	Data Set-up to Write End	15		20		20		ns
t _{HD}	Data Hold from Write End	0		0		0		ns
t _{HZWE}	R/W LOW to High Z ^[9]		20		20		25	ns
t _{LZWE}	R/W HIGH to Low Z ^[9]	0		0		0		ns
Busy/Interrupt Timing								
t _{BLA}	BUSY LOW from Address Match		20		25		30	ns
t _{BHA}	BUSY HIGH from Address Mismatch ^[15]		20		25		30	ns
t _{BLC}	BUSY LOW from CE LOW		20		25		30	ns
t _{BHC}	BUSY HIGH from CE HIGH ^[15]		20		25		30	ns
t _{PS}	Port Set Up for Priority	5		5		5		ns
t _{WB}	R/W LOW after BUSY LOW ^[16]	0		0		0		ns
t _{WH}	R/W HIGH after BUSY HIGH	30		35		35		ns
t _{BDD}	BUSY HIGH to Valid Data		35		45		45	ns
t _{DDD}	Write Data Valid to Read Data Valid		Note 17		Note 17		Note 17	ns
t _{WDD}	Write Pulse to Data Delay		Note 17		Note 17		Note 17	ns
Interrupt Timing^[18]								
t _{WINS}	R/W to INTERRUPT Set Time		25		35		45	ns
t _{EINS}	CE to INTERRUPT Set Time		25		35		45	ns
t _{INS}	Address to INTERRUPT Set Time		25		35		45	ns
t _{OINR}	OE to INTERRUPT Reset Time ^[15]		25		35		45	ns
t _{EINR}	CE to INTERRUPT Reset Time ^[15]		25		35		45	ns
t _{INR}	Address to INTERRUPT Reset Time ^[15]		25		35		45	ns

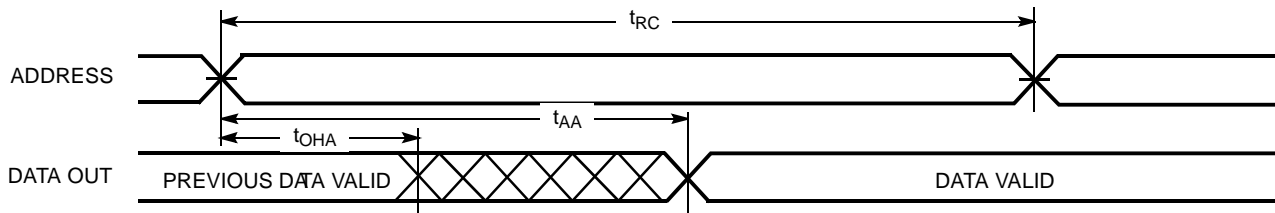
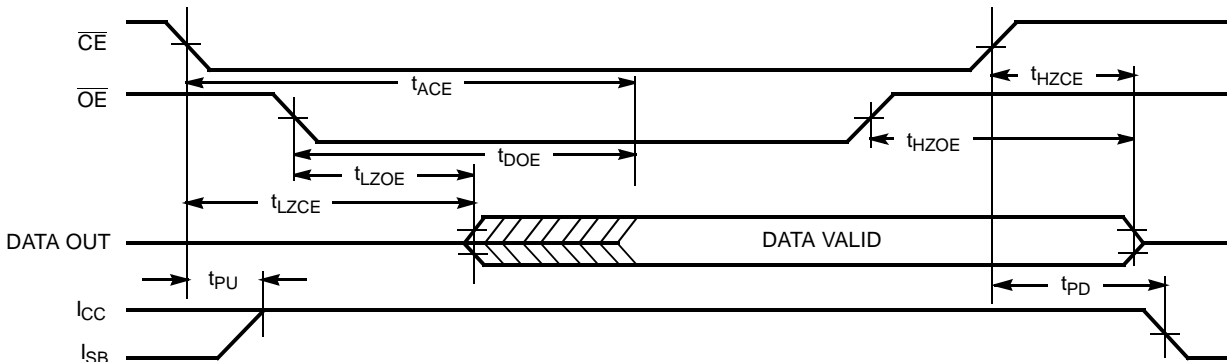
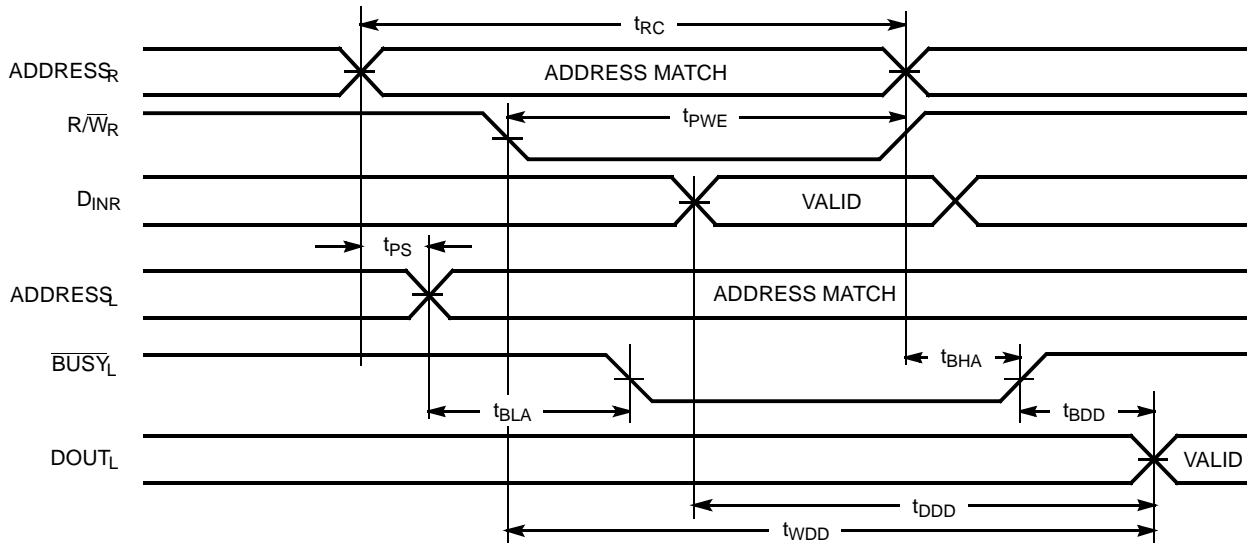
Switching Waveforms
Read Cycle No. 1 (Either Port-Address Access)^[19, 20]

Read Cycle No. 2 (Either Port- $\overline{CE}/\overline{OE}$)^[19, 21]

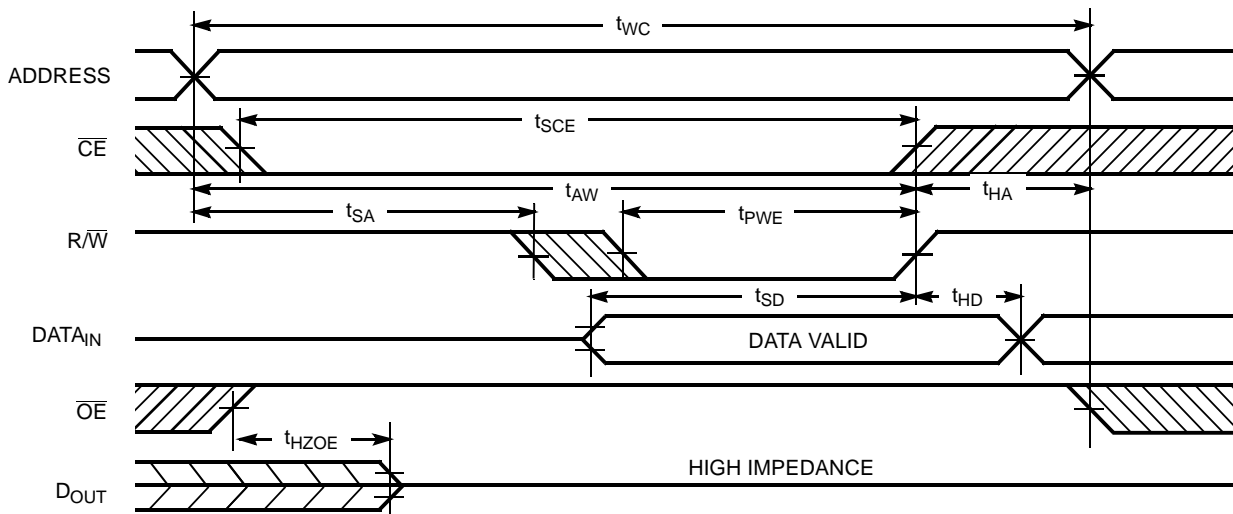
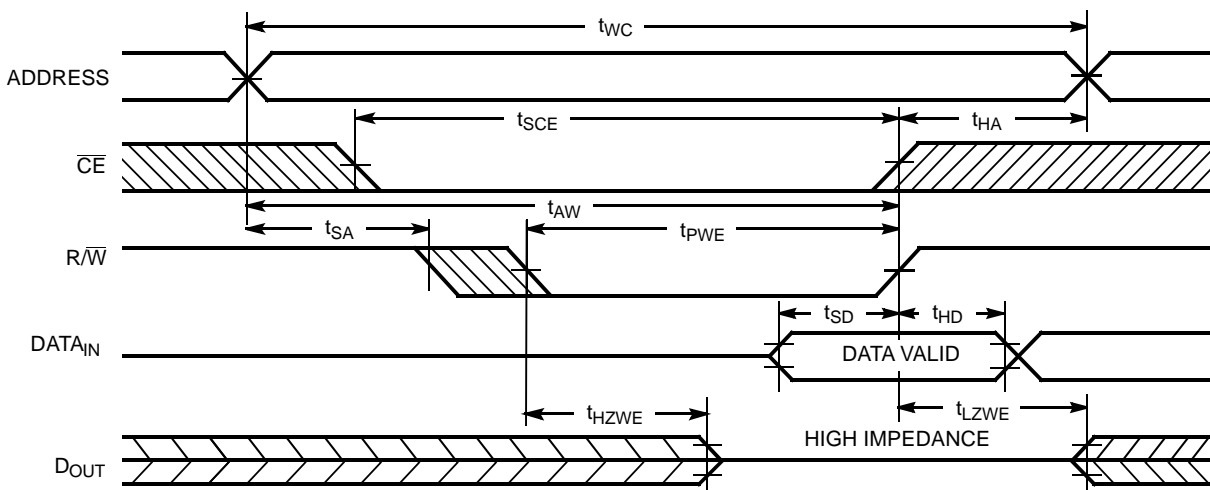
Read Cycle No. 3 (Read with \overline{BUSY} Master: CY7C132 and CY7C136)

Notes:

19. R/W is HIGH for read cycle.
20. Device is continuously selected, $\overline{CE} = V_{IL}$ and $\overline{OE} = V_{IL}$.
21. Address valid prior to or coincident with CE transition LOW.

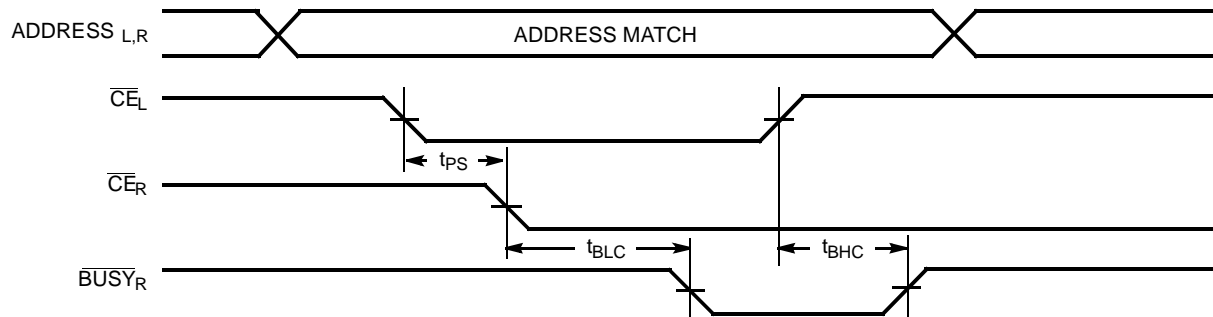
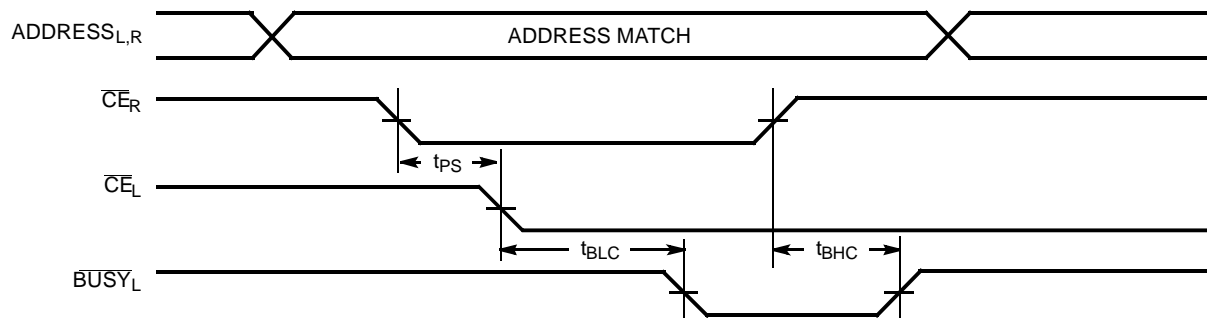
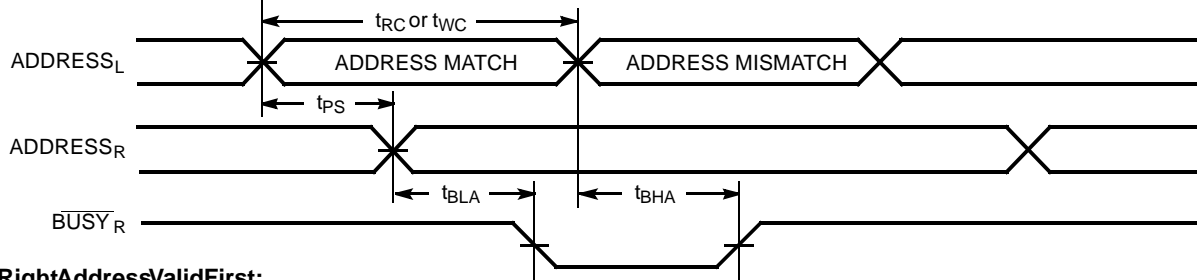
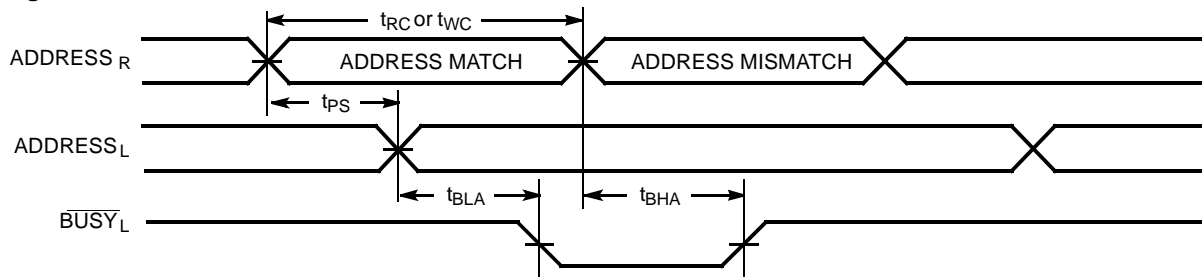
Switching Waveforms (continued)
Write Cycle No.1 (\overline{OE} Three-States Data I/Os—Either Port)^[14, 22]

Write Cycle No. 2 ($\overline{R/\overline{W}}$ Three-States Data I/Os—Either Port)^[14, 23]

Notes:

22. If \overline{OE} is LOW during a $\overline{R/\overline{W}}$ controlled write cycle, the write pulse width must be the larger of t_{PWE} or $t_{HZWE} + t_{SD}$ to allow the data I/O pins to enter high impedance and for data to be placed on the bus for the required t_{SD} .
23. If the \overline{CE} LOW transition occurs simultaneously with or after the $\overline{R/\overline{W}}$ LOW transition, the outputs remain in a high-impedance state.

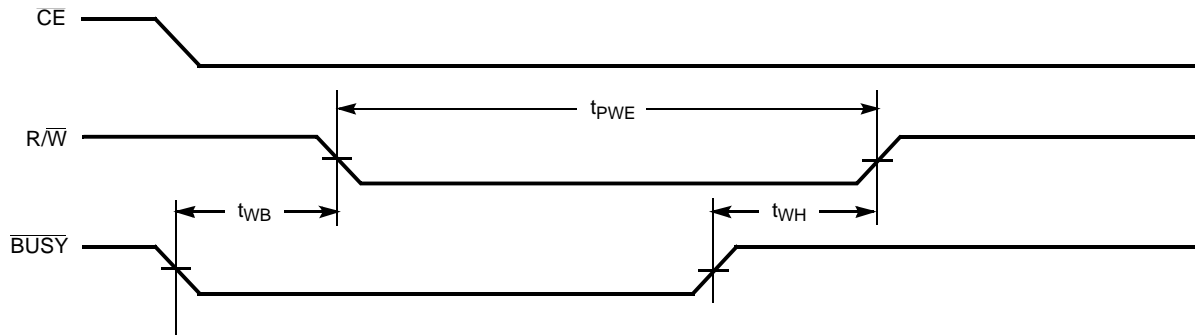
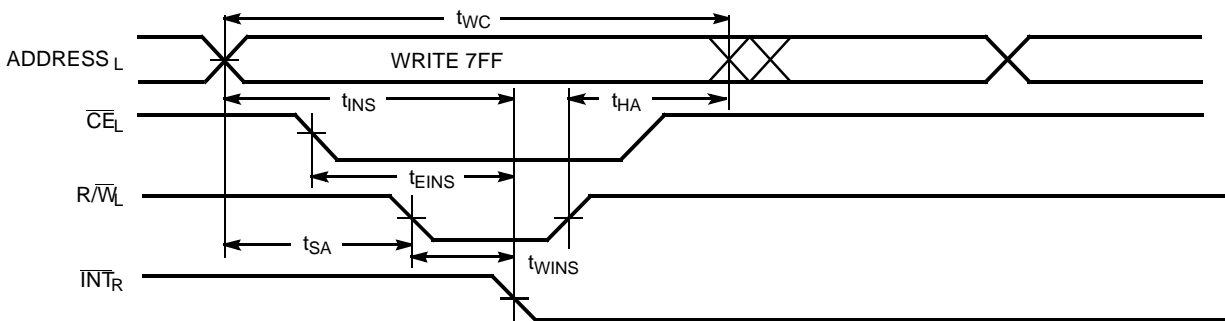
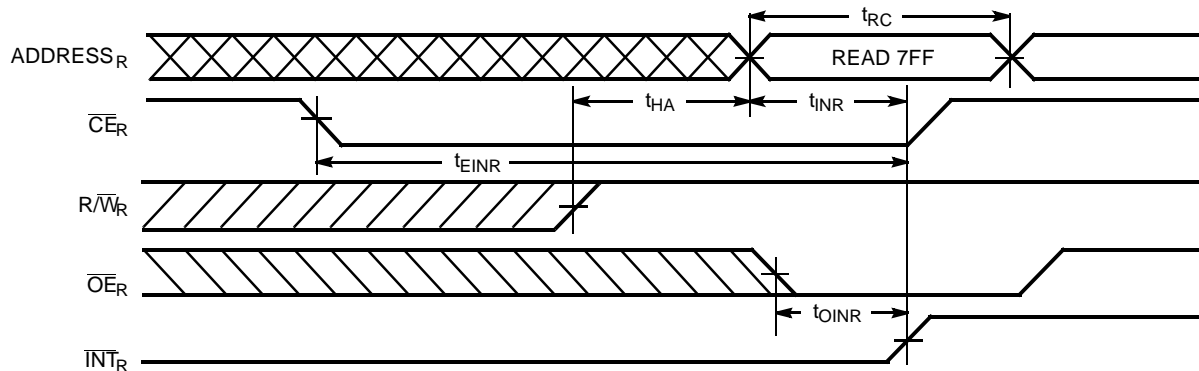
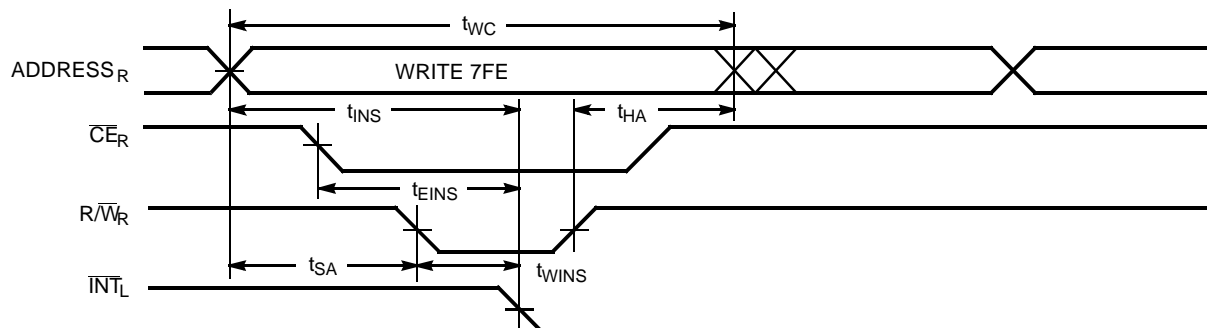
Switching Waveforms (continued)

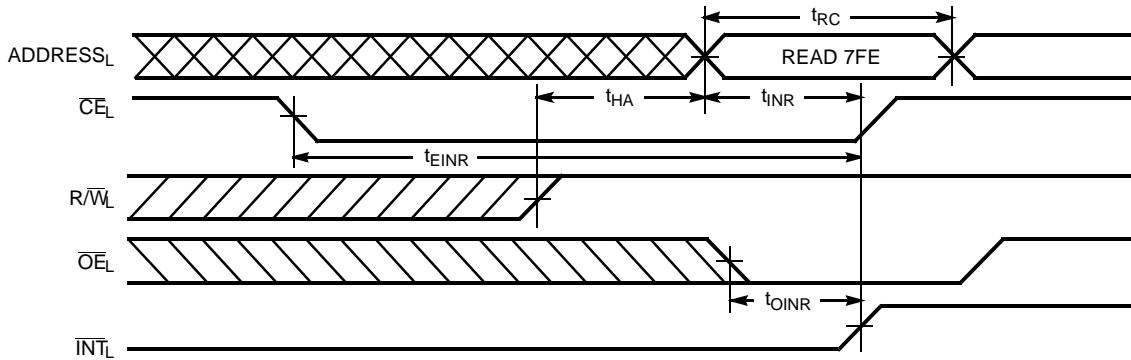
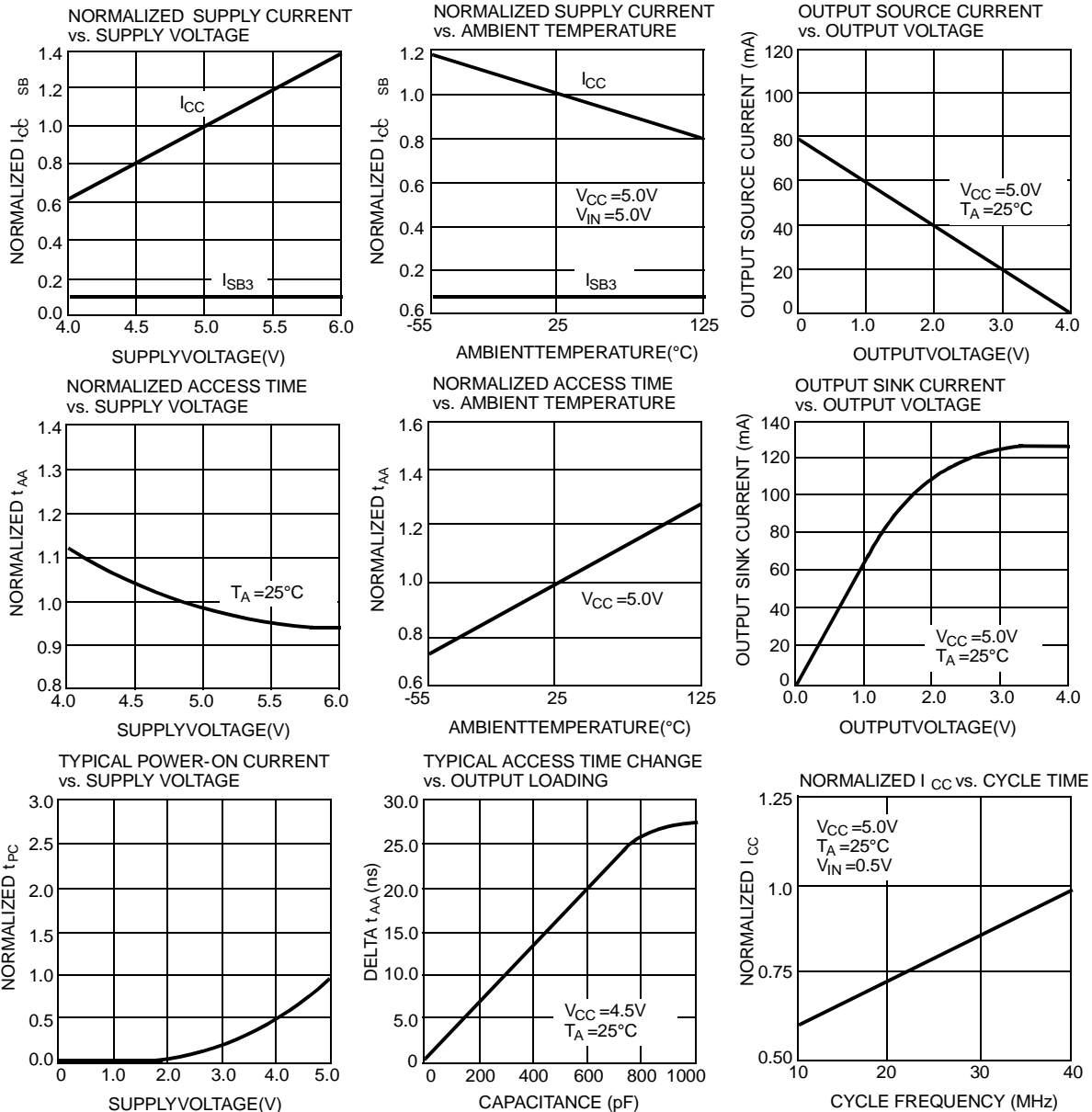
Busy Timing Diagram No. 1 (\overline{CE} Arbitration)
 \overline{CE}_L Valid First:

 \overline{CE}_R Valid First:

Busy Timing Diagram No. 2 (Address Arbitration)
Left Address Valid First:

Right Address Valid First:

Switching Waveforms (continued)
Busy Timing Diagram No. 3 (Write with $\overline{\text{BUSY}}$, Slave: CY7C142/CY7C146)

Interrupt Timing Diagrams^[18]
Left Side Sets $\overline{\text{INT}}_R$:

Right Side Clears $\overline{\text{INT}}_R$:

Right Side Sets $\overline{\text{INT}}_L$:

Interrupt Timing Diagrams^[18] (continued)
Right Side Clears INT_L:

Typical DC and AC Characteristics



Ordering Information

Speed (ns)	Ordering Code	Package Name	Package Type	Operating Range
30	CY7C132-30PC	P25	48-Lead (600-Mil) Molded DIP	Commercial
	CY7C132-30PI	P25	48-Lead (600-Mil) Molded DIP	Industrial
35	CY7C132-35PC	P25	48-Lead (600-Mil) Molded DIP	Commercial
	CY7C132-35PI	P25	48-Lead (600-Mil) Molded DIP	Industrial
	CY7C132-35DMB	D26	48-Lead (600-Mil) Sidebrazed DIP	Military
45	CY7C132-45PC	P25	48-Lead (600-Mil) Molded DIP	Commercial
	CY7C132-45PI	P25	48-Lead (600-Mil) Molded DIP	Industrial
	CY7C132-45DMB	D26	48-Lead (600-Mil) Sidebrazed DIP	Military
55	CY7C132-55PC	P25	48-Lead (600-Mil) Molded DIP	Commercial
	CY7C132-55PI	P25	48-Lead (600-Mil) Molded DIP	Industrial
	CY7C132-55DMB	D26	48-Lead (600-Mil) Sidebrazed DIP	Military
15	CY7C136-15JC	J69	52-Lead Plastic Leaded Chip Carrier	Commercial
	CY7C136-15NC	N52	52-Pin Plastic Quad Flatpack	
25	CY7C136-25JC	J69	52-Lead Plastic Leaded Chip Carrier	Commercial
	CY7C136-25NC	N52	52-Pin Plastic Quad Flatpack	
30	CY7C136-30JC	J69	52-Lead Plastic Leaded Chip Carrier	Commercial
	CY7C136-30NC	N52	52-Pin Plastic Quad Flatpack	
	CY7C136-30JI	J69	52-Lead Plastic Leaded Chip Carrier	Industrial
35	CY7C136-35JC	J69	52-Lead Plastic Leaded Chip Carrier	Commercial
	CY7C136-35NC	N52	52-Pin Plastic Quad Flatpack	
	CY7C136-35JI	J69	52-Lead Plastic Leaded Chip Carrier	Industrial
	CY7C136-35LMB	L69	52-Square Leadless Chip Carrier	Military
45	CY7C136-45JC	J69	52-Lead Plastic Leaded Chip Carrier	Commercial
	CY7C136-45NC	N52	52-Pin Plastic Quad Flatpack	
	CY7C136-45JI	J69	52-Lead Plastic Leaded Chip Carrier	Industrial
	CY7C136-45LMB	L69	52-Square Leadless Chip Carrier	Military
55	CY7C136-55JC	J69	52-Lead Plastic Leaded Chip Carrier	Commercial
	CY7C136-55NC	N52	52-Pin Plastic Quad Flatpack	
	CY7C136-55JI	J69	52-Lead Plastic Leaded Chip Carrier	Industrial
	CY7C136-55NI	N52	52-Pin Plastic Quad Flatpack	
	CY7C136-55LMB	L69	52-Square Leadless Chip Carrier	Military
30	CY7C142-30PC	P25	48-Lead (600-Mil) Molded DIP	Commercial
	CY7C142-30PI	P25	48-Lead (600-Mil) Molded DIP	Industrial
35	CY7C142-35PC	P25	48-Lead (600-Mil) Molded DIP	Commercial
	CY7C142-35PI	P25	48-Lead (600-Mil) Molded DIP	Industrial
	CY7C142-35DMB	D26	48-Lead (600-Mil) Sidebrazed DIP	Military
45	CY7C142-45PC	P25	48-Lead (600-Mil) Molded DIP	Commercial
	CY7C142-45PI	P25	48-Lead (600-Mil) Molded DIP	Industrial
	CY7C142-45DMB	D26	48-Lead (600-Mil) Sidebrazed DIP	Military
55	CY7C142-55PC	P25	48-Lead (600-Mil) Molded DIP	Commercial
	CY7C142-55PI	P25	48-Lead (600-Mil) Molded DIP	Industrial
	CY7C142-55DMB	D26	48-Lead (600-Mil) Sidebrazed DIP	Military

Shaded areas contain preliminary information.

Ordering Information (continued)

Speed (ns)	Ordering Code	Package Name	Package Type	Operating Range
15	CY7C146-15JC	J69	52-Lead Plastic Leaded Chip Carrier	Commercial
	CY7C146-15NC	N52	52-Pin Plastic Quad Flatpack	
25	CY7C146-25JC	J69	52-Lead Plastic Leaded Chip Carrier	Commercial
	CY7C146-25NC	N52	52-Pin Plastic Quad Flatpack	
30	CY7C146-30JC	J69	52-Lead Plastic Leaded Chip Carrier	Commercial
	CY7C146-30NC	N52	52-Pin Plastic Quad Flatpack	
	CY7C146-30JI	J69	52-Lead Plastic Leaded Chip Carrier	Industrial
35	CY7C146-35JC	J69	52-Lead Plastic Leaded Chip Carrier	Commercial
	CY7C146-35NC	N52	52-Pin Plastic Quad Flatpack	
	CY7C146-35JI	J69	52-Lead Plastic Leaded Chip Carrier	Industrial
	CY7C146-35LMB	L69	52-Square Leadless Chip Carrier	Military
45	CY7C146-45JC	J69	52-Lead Plastic Leaded Chip Carrier	Commercial
	CY7C146-45NC	N52	52-Pin Plastic Quad Flatpack	
	CY7C146-45JI	J69	52-Lead Plastic Leaded Chip Carrier	Industrial
	CY7C146-45LMB	L69	52-Square Leadless Chip Carrier	Military
55	CY7C146-55JC	J69	52-Lead Plastic Leaded Chip Carrier	Commercial
	CY7C146-55NC	N52	52-Pin Plastic Quad Flatpack	
	CY7C146-55JI	J69	52-Lead Plastic Leaded Chip Carrier	Industrial
	CY7C146-55LMB	L69	52-Square Leadless Chip Carrier	Military

MILITARY SPECIFICATIONS
Group A Subgroup Testing—DC Characteristics

Parameter	Subgroups
V _{OH}	1, 2, 3
V _{OL}	1, 2, 3
V _{IH}	1, 2, 3
V _{IL} Max.	1, 2, 3
I _{IX}	1, 2, 3
I _{OZ}	1, 2, 3
I _{CC}	1, 2, 3
I _{SB1}	1, 2, 3
I _{SB2}	1, 2, 3
I _{SB3}	1, 2, 3
I _{SB4}	1, 2, 3

Switching Characteristics

Parameter	Subgroups
Read Cycle	
t _{RC}	7, 8, 9, 10, 11
t _{AA}	7, 8, 9, 10, 11
t _{ACE}	7, 8, 9, 10, 11
t _{DOE}	7, 8, 9, 10, 11
Write Cycle	
t _{WC}	7, 8, 9, 10, 11
t _{SCE}	7, 8, 9, 10, 11

Switching Characteristics (continued)

Parameter	Subgroups
t _{AW}	7, 8, 9, 10, 11
t _{HA}	7, 8, 9, 10, 11
t _{SA}	7, 8, 9, 10, 11
t _{PWE}	7, 8, 9, 10, 11
t _{SD}	7, 8, 9, 10, 11
t _{HD}	7, 8, 9, 10, 11
Busy/Interrupt Timing	
t _{BLA}	7, 8, 9, 10, 11
t _{BHA}	7, 8, 9, 10, 11
t _{BLC}	7, 8, 9, 10, 11
t _{BHC}	7, 8, 9, 10, 11
t _{PS}	7, 8, 9, 10, 11
t _{WINS}	7, 8, 9, 10, 11
t _{EINS}	7, 8, 9, 10, 11
t _{INS}	7, 8, 9, 10, 11
t _{OINR}	7, 8, 9, 10, 11
t _{EINR}	7, 8, 9, 10, 11
t _{INR}	7, 8, 9, 10, 11
BUSY TIMING	
t _{WB} ^[24]	7, 8, 9, 10, 11
t _{WH}	7, 8, 9, 10, 11
t _{BDD}	7, 8, 9, 10, 11

Note:

24. CY7C142/CY7C146 only.

Package Diagrams

48-Lead (600-Mil) Sidebrazed DIP D26
MIL-STD-1835 D-14 Config. C

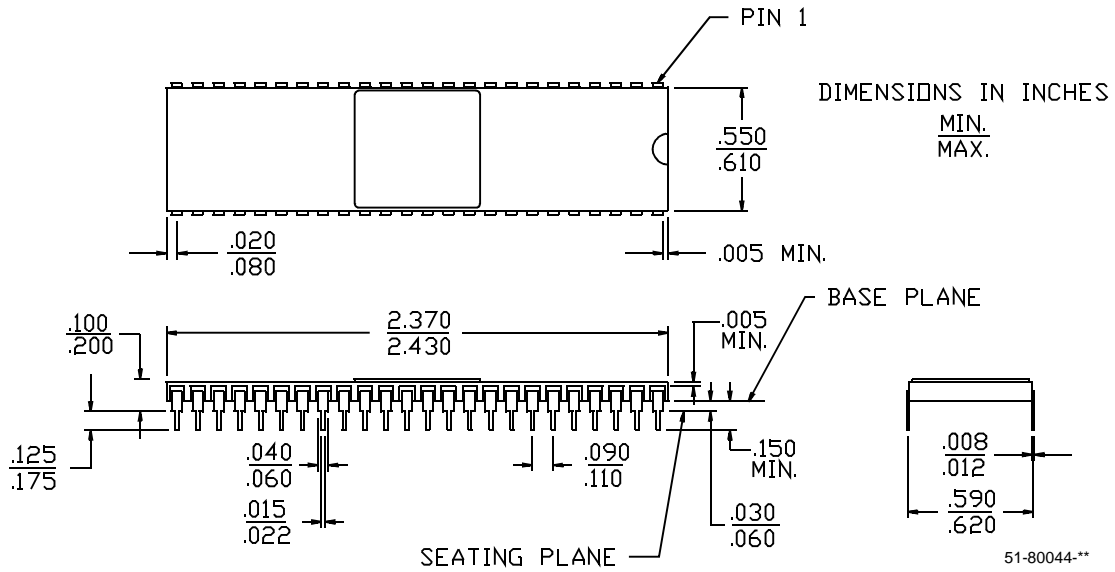

52-Lead Plastic Leaded Chip Carrier J69

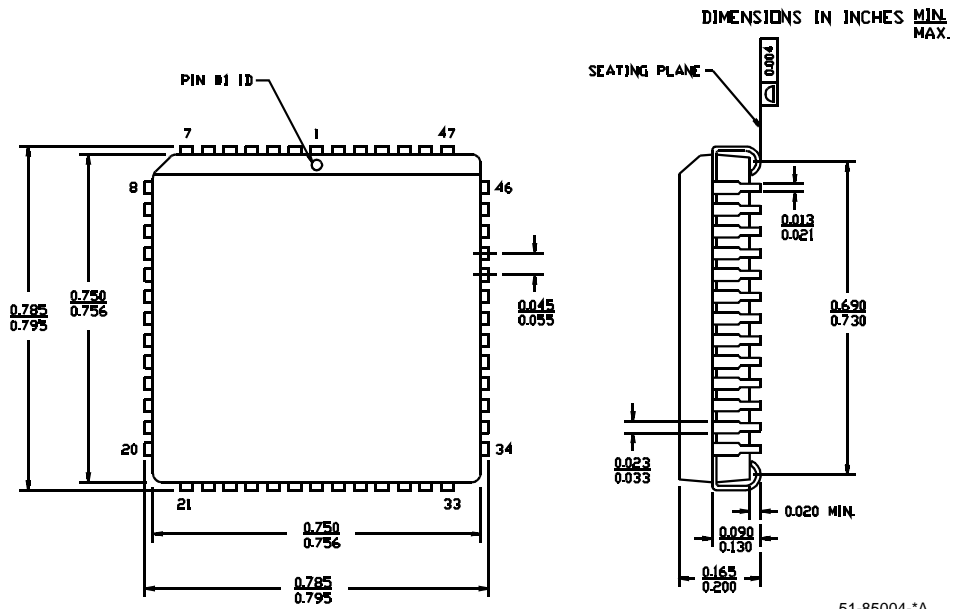

Package Diagrams (continued)

52-Square Leadless Chip Carrier L69

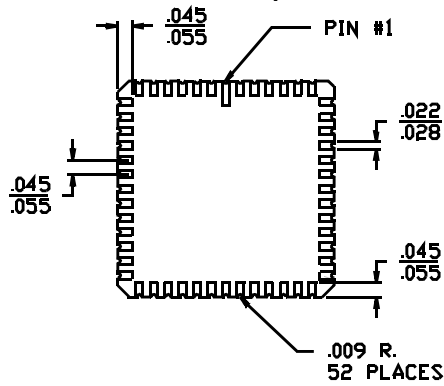

DIMENSIONS IN INCHES

MIN.
MAX.

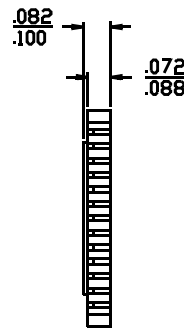
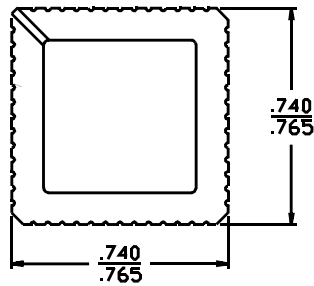

51-80054-**

52-Lead Plastic Quad Flatpack N52

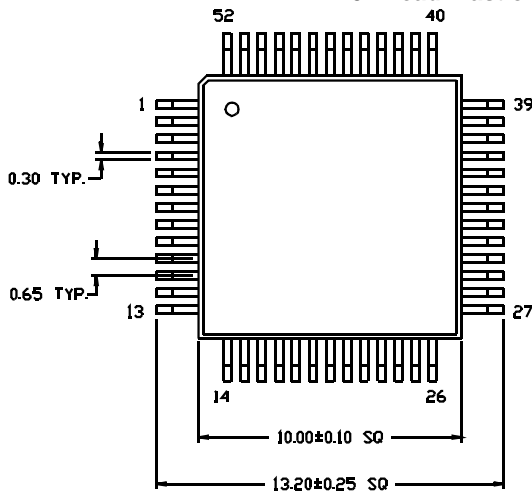

DIMENSIONS ARE IN MILLIMETERS

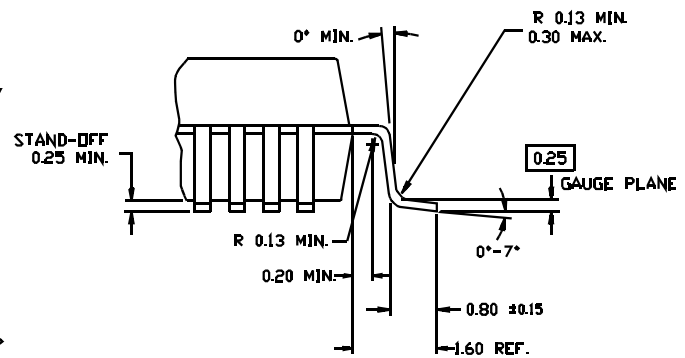

DETAIL A

51-85042-**

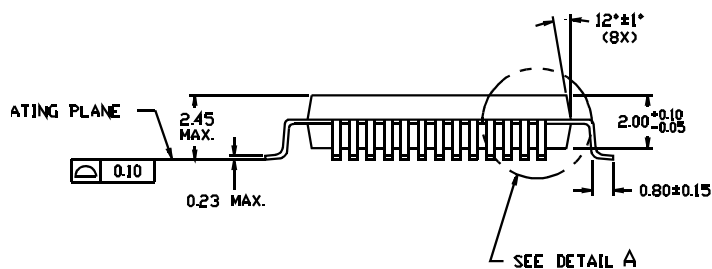

SEE DETAIL A

Package Diagrams (continued)

48-Lead (600-Mil) Molded DIP P25

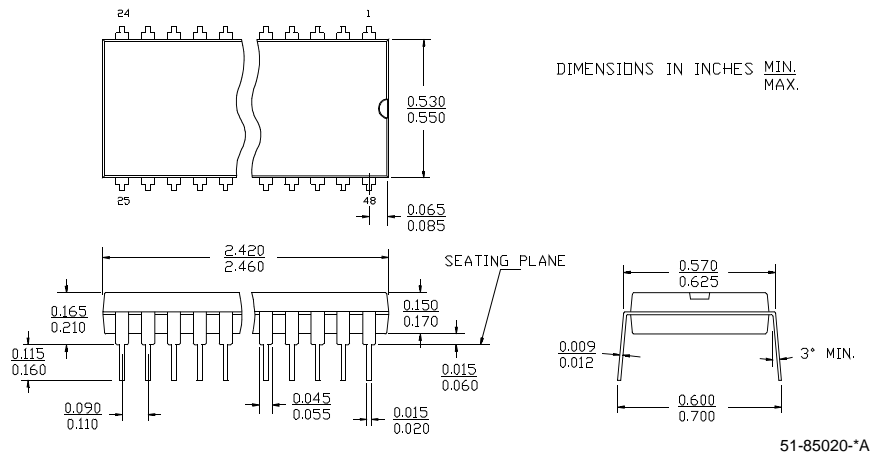

All product and company names mentioned in this document are the trademarks of their respective holders.



Document History Page

Document Title: CY7C132 / CY7C136 / CY7C142 / CY7C146 2K x 8 Dual Port Static RAM				
Document Number: 38-06031				
REV.	ECN NO.	Issue Date	Orig. of Change	Description of Change
**	110171	10/21/01	SZV	Change from Spec number: 38-06031
*A	128959	09/03/03	JFU	Added CY7C136-55NI to Order Information
*B	236748	See ECN	YDT	Removed cross information from features section



LittleDiode supplies new, hard to find or obsolete electronic components and semiconductors all over the world.

With over two million different components listed you are sure to find the part you need.

Feel free to visit us today at our online store:

LittleDiode.com

Looking forward to providing you with the best possible service.