



Integrated Device Technology, Inc.

# CMOS StaticRAM 16K (4K x 4-BIT) CACHE-TAG RAM

IDT6178S

## FEATURES:

- High-speed Address to MATCH Valid time
  - Military: 12/15/20/25ns
  - Commercial: 10/12/15/20/25ns (max.)
- High-speed Address Access time
  - Military: 12/15/20/25ns
  - Commercial: 10/12/15/20/25ns (max.)
- Low-power consumption
  - IDT6178S
 Active: 300mW (typ.)
- Produced with advanced CMOS high-performance technology
- Input and output TTL-compatible
- Standard 22-pin Plastic or Ceramic DIP, 24-pin SOJ
- Military product 100% compliant to MIL-STD-883, Class B

## DESCRIPTION:

The IDT6178 is a high-speed cache address comparator sub-system consisting of a 16,384-bit StaticRAM organized as 4K x 4. Cycle Time and Address to MATCH Valid are equal. The IDT6178 features an onboard 4-bit comparator that compares RAM contents and current input data. The result is an active HIGH on the MATCH pin. The MATCH pins of several IDT6178s can be handed together to provide enabling or acknowledging signals to the data cache or processor.

The IDT6178 is fabricated using IDT's high-performance, high-reliability CMOS technology. Address to MATCH and Data to MATCH times are as fast as 10ns.

All inputs and outputs of the IDT6178 are TTL-compatible and the device operates from a single 5V supply.

The IDT6178 is packaged in either a 22-pin, 300-mil Plastic or Ceramic DIP package or 24-pin SOJ. Military grade product is manufactured in compliance with latest revision of MIL-STD-883, Class B, making it ideally suited to military temperature applications demanding the highest level of performance and reliability.

## FUNCTIONAL BLOCK DIAGRAM

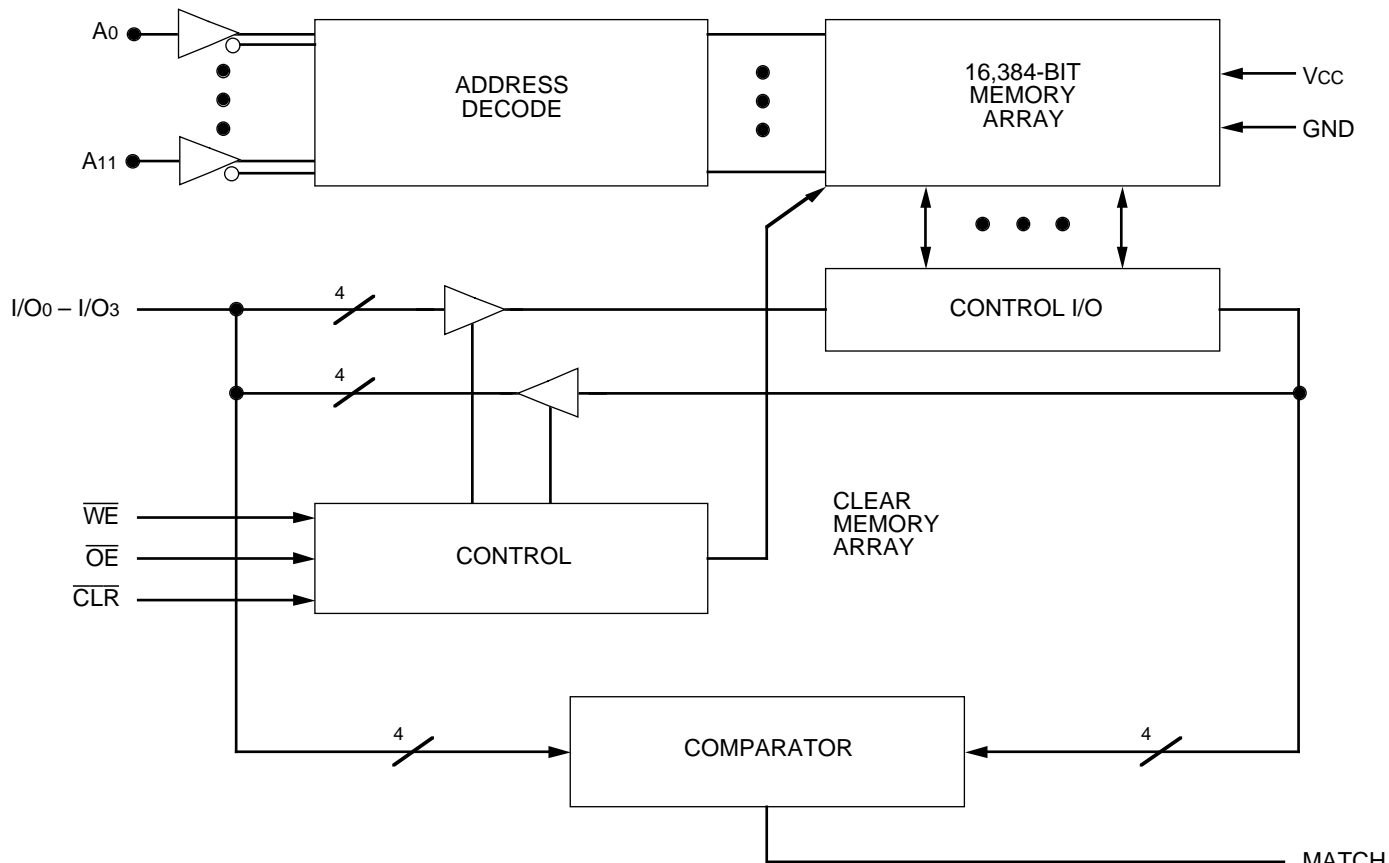

The IDT logo is a registered trademark of Integrated Device Technology, Inc.

2953 drw 01

**PIN CONFIGURATIONS**

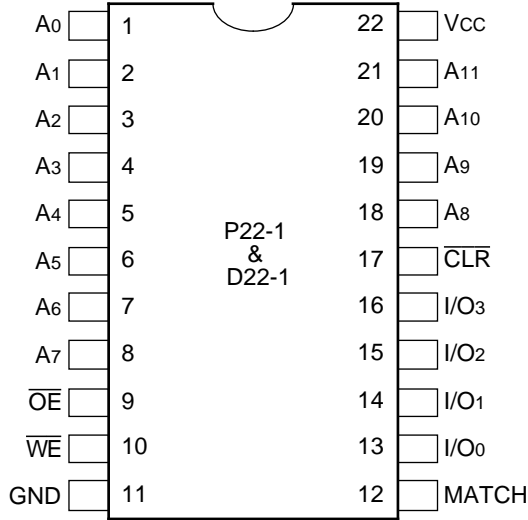

**DIP  
TOP VIEW**

2953 drw 02

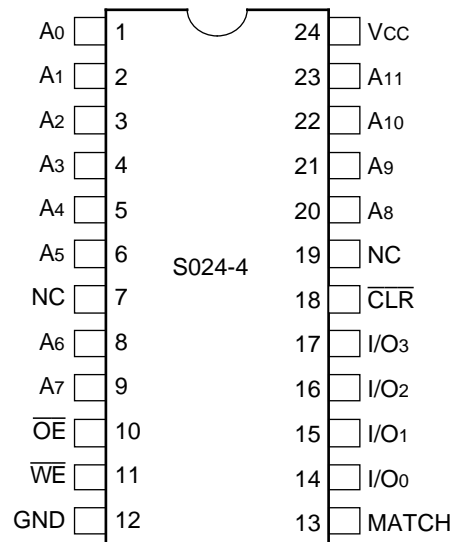

**SOJ  
TOP VIEW**

2953 drw 03

**PIN DESCRIPTIONS**

A <sub>0</sub> –A <sub>11</sub>	Address Inputs
I/O <sub>0</sub> –I/O <sub>3</sub>	Data Input/Output
MATCH	Match
WE	Write Enable
OE	Output Enable
CLR	Clear
VCC	Power
GND	Ground

2953 tbl 01

**RECOMMENDED OPERATING TEMPERATURE AND SUPPLY VOLTAGE**

Grade	Ambient Temperature	GND	Vcc
Commercial	0°C to +70°C	0V	5.0V ± 10%
Military	–55°C to +125°C	0V	5.0V ± 10%

2953 tbl 02

**TRUTH TABLES<sup>(1)</sup>**

WE	OE	CLR	MATCH	Mode
H	H	H	Valid <sup>(2)</sup>	Match Cycle
L	X	H	Invalid	Write Cycle
H	L	H	Invalid	Read Cycle
X	X	L	Invalid	Clear Cycle

**NOTE:**

- H = V<sub>IH</sub>, L = V<sub>IL</sub>, X = Don't care.
- Valid Match = V<sub>OH</sub>, Valid Non-Match = V<sub>OL</sub>.

2953 tbl 03

**ABSOLUTE MAXIMUM RATINGS<sup>(1)</sup>**

Symbol	Rating	Value	Unit
V <sub>TERM</sub>	Terminal Voltage with respect to GND	–0.5 to +7.0	V
T <sub>A</sub>	Operating Temperature	–55 to +125	°C
T <sub>BIAS</sub>	Temperature Under Bias	–65 to +135	°C
T <sub>STG</sub>	Storage Temperature	–65 to +150	°C
P <sub>T</sub>	Power Dissipation	1.0	W
I <sub>OUT</sub>	DC Output Current	50	mA

**NOTE:**

- Stresses greater than those listed under ABSOLUTE MAXIMUM RATINGS may cause permanent damage to the device. This is a stress rating only and functional operation of the device at these or any other conditions above those indicated in the operational sections of this specification is not implied. Exposure to absolute maximum rating conditions for extended periods may affect reliability.

2953 tbl 04

**RECOMMENDED DC OPERATING CONDITIONS**

Symbol	Parameter	Min.	Typ.	Max.	Unit
VCC	Supply Voltage	4.5	5.0	5.5	V
GND	Supply Voltage	0	0	0	V
V <sub>IH</sub>	Input High Voltage	2.2 <sup>(2)</sup>	–	6.0	V
V <sub>IL</sub>	Input Low Voltage	–0.5 <sup>(1)</sup>	–	0.8	V

**NOTES:**

- V<sub>IL</sub> = –3.0V for pulse width less than 20ns, once per cycle.
- V<sub>IH</sub> = 2.5V for clear pin.

2953 tbl 05

**CAPACITANCE (T<sub>A</sub> = 25°C, f = 1MHz)**

Symbol	Parameter	Condition	Max	Units
C <sub>IN</sub>	Input Capacitance	V <sub>IN</sub> = 0V	8	pF
C <sub>I/O</sub>	I/O Capacitance	V <sub>OUT</sub> = 0V	8	pF

**NOTE:**

- This parameter is determined by device characterization, but is not production tested.

2953 tbl 06

**DC ELECTRICAL CHARACTERISTICS** ( $V_{CC} = 5.0V \pm 10\%$ , All Temperature Ranges)

Symbol	Parameter	Test Condition	6178S		Unit
			Min.	Max.	
I <sub>LI</sub>	Input Leakage Current	$V_{CC} = 5.5V, V_{IN} = 0V \text{ to } V_{CC}$	—	10	μA
I <sub>LO</sub>	Output Leakage Current	$\overline{OE} = V_{IH}, V_{OUT} = 0V \text{ to } V_{CC}$	—	10	μA
V <sub>OL</sub>	Output Low Voltage	I <sub>OL</sub> = 8mA (I/O <sub>0</sub> – I/O <sub>3</sub> )	—	0.4	V
		I <sub>OL</sub> = 10mA (I/O <sub>0</sub> – I/O <sub>3</sub> )	—	0.5	V
		I <sub>OL</sub> = 16mA (Match)	—	0.4	V
		I <sub>OL</sub> = 20mA (Match)	—	0.5	V
V <sub>OH</sub>	Output High Voltage	I <sub>OH</sub> = –4mA (I/O <sub>0</sub> – I/O <sub>3</sub> )	2.4	—	V
		I <sub>OH</sub> = –8mA (Match)	2.4	—	V

2953 tbl 07

**DC ELECTRICAL CHARACTERISTICS** ( $V_{CC} = 5.0V \pm 10\%$ , All Temperature Ranges)

Symbol	Parameter		6178S10 Max.	6178S12 <sup>(1)</sup> Max.	6178S15 <sup>(1)</sup> Max.	6178S20/25 Max.	Unit
I <sub>CC1</sub>	Operating Power Supply Current Outputs Open, $V_{CC} = \text{Max.}, f = 0^{(2)}$	COM'L.	90	90	90	90	mA
		MIL.	—	110	110	110	mA
I <sub>CC2</sub>	Dynamic Operating Current Outputs Open, $V_{CC} = \text{Max.}, f = f_{\text{MAX}}^{(2)}$	COM'L.	180	160	140	140	mA
		MIL.	—	180	160	160	mA

2953 tbl 08

**NOTES:**

- Military values are preliminary only.
- $f_{\text{MAX}} = 1/\text{trc}$ , only address inputs are cycling at  $f_{\text{MAX}}$ .  $f = 0$  means no address inputs change.

**AC TEST CONDITIONS**

Input Pulse Levels	GND to 3.0V
Input Rise/Fall Times	5ns
Input Timing Reference Levels	1.5V
Output Reference Levels	1.5V
AC Test Load	See Figures 2 and 3
AC Test Load for Match Cycle	See Figure 1

2953 tbl 09

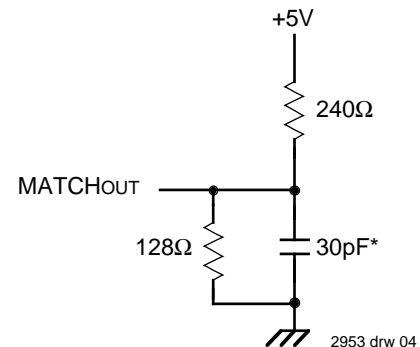

Figure 1. AC Test Load for MATCH

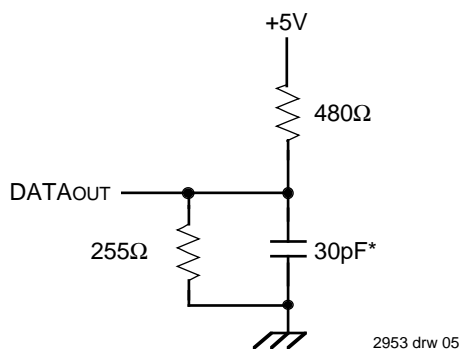

Figure 2. AC Test Load

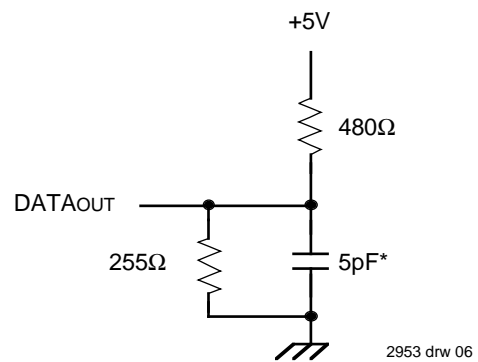

Figure 3. AC Test Load  
(for tOLZ, tOHZ, tWHZ, tOW)

\* Including scope and jig.

## CYCLE DESCRIPTION

**Match Cycle:** A match cycle occurs when all control signals ( $\overline{OE}$ ,  $\overline{WE}$ ,  $\overline{CLR}$ ) are HIGH. At that time, data supplied to the RAM on the I/O pins is compared with the data stored at the specified address. The totem-pole match output is HIGH when there is a match at all data bits, and drives LOW if there is not a match.

**Write Cycle:** The write cycle is conventional, occurring when  $\overline{WE}$  is LOW and  $\overline{CLR}$  is HIGH.  $\overline{OE}$  may be either HIGH or LOW, since it is overridden by  $\overline{WE}$ . The state of the Match pin is not guaranteed, but in the current implementation it continues to reflect the output of the comparator. The Match pin goes HIGH during write cycles since the data at the specified address is the same as the data (being written) at the I/Os of the RAM.

**Read Cycle:** When  $\overline{WE}$  and  $\overline{CLR}$  are HIGH and  $\overline{OE}$  is LOW, the RAM is in a read cycle. The state of the Match pin is not guaranteed, but in the current implementation it continues to reflect the output of the comparator. The Match pin goes HIGH during read cycles since the data at the specified address is the same as the data (being read) at the I/Os of the RAM.

**Clear Cycle:** When  $\overline{CLR}$  is asserted, every bit in the RAM is cleared to zero. If  $\overline{OE}$  is LOW during a clear cycle, the RAM I/Os will be driven. However, this data is not necessarily zeros, even after a considerable time. The Match pin is enabled, but its state is not predicable.

## AC ELECTRICAL CHARACTERISTICS (V<sub>CC</sub> = 5.0V ± 10%, All Temperature Ranges)

Symbol	Parameter	6178S10 <sup>(1)</sup>		6178S12		6178S15		6178S20		6178S25		Unit
		Min.	Max.	Min.	Max.	Min.	Max.	Min.	Max.	Min.	Max.	
<b>Match Cycle</b>												
t <sub>ADM</sub>	Address to Match Valid	—	10	—	12	—	15	—	20	—	25	ns
t <sub>DAM</sub>	Data Input to Match Valid	—	8	—	11	—	13	—	15	—	15	ns
t <sub>MHO</sub>	Match Valid Hold from $\overline{OE}$	0	—	0	—	0	—	0	—	0	—	ns
t <sub>OEM</sub>	$\overline{OE}$ HIGH to Match Valid	—	10	—	12	—	15	—	20	—	20	ns
t <sub>MHW</sub>	Match Valid Hold from $\overline{WE}$	0	—	0	—	0	—	0	—	0	—	ns
t <sub>WEM</sub>	$\overline{WE}$ HIGH to Match Valid	—	10	—	12	—	15	—	20	—	20	ns
t <sub>MHCLR</sub>	Match Valid Hold from $\overline{CLR}$	0	—	0	—	0	—	0	—	0	—	ns
t <sub>MHA</sub>	Match Valid Hold from Address	3	—	3	—	3	—	3	—	3	—	ns
t <sub>MHD</sub>	Match Valid Hold from Data	3	—	3	—	3	—	3	—	3	—	ns

### NOTE:

1. 0°C to +70°C temperature range only.

2953 tbl 10

## TIMING WAVEFORM OF MATCH CYCLE<sup>(1)</sup>

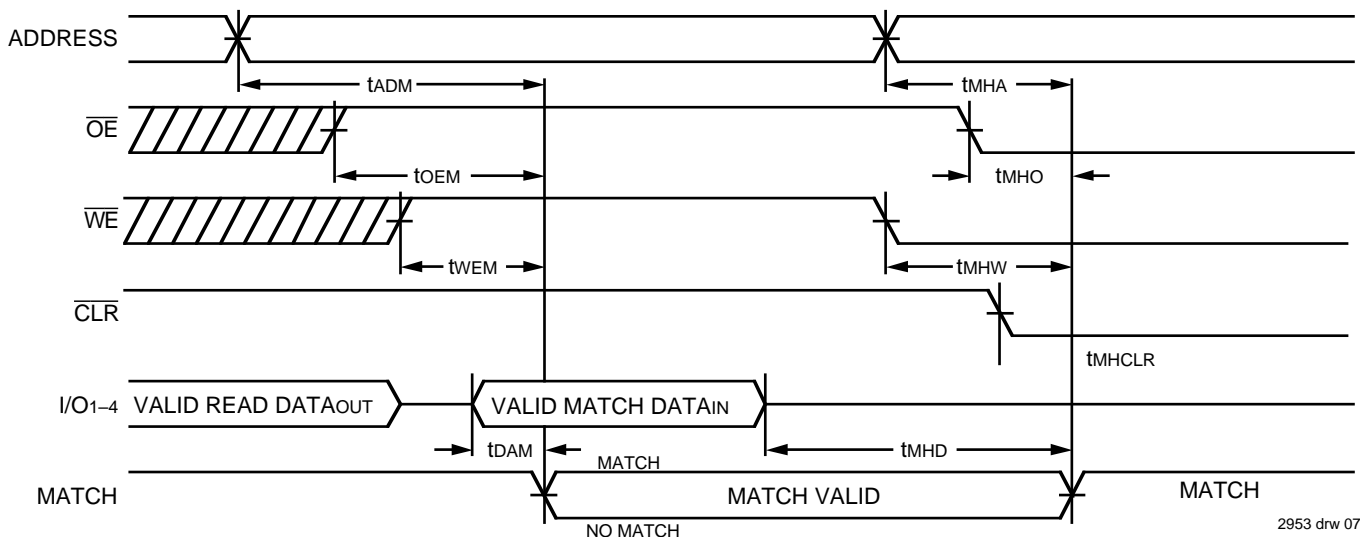

2953 drw 07

### NOTE:

1. It is not recommended to let address and data input pins float while MATCH pin is active.

**AC ELECTRICAL CHARACTERISTICS** ( $V_{CC} = 5.0V \pm 10\%$ , All Temperature Ranges)

Symbol	Parameter	6178S10 <sup>(1)</sup>		6178S12		6178S15		6178S20/25		Unit
		Min.	Max.	Min.	Max.	Min.	Max.	Min.	Max.	
<b>Read Cycle</b>										
t <sub>RC</sub>	Read Cycle Time	10	—	12	—	15	—	20/25	—	ns
t <sub>AA</sub>	Address Access Time	—	10	—	12	—	15	—	20/25	ns
t <sub>OE</sub>	Output Enable Access Time	—	7	—	8	—	10	—	15	ns
t <sub>OH</sub>	Output Hold from Address Change	3	—	3	—	3	—	3	—	ns
t <sub>OLZ</sub> <sup>(2)</sup>	Output Enable to Output in Low-Z Time	2	—	2	—	2	—	2	—	ns
t <sub>OHZ</sub> <sup>(2)</sup>	Output Disable to Output in High-Z Time	—	6	—	7	—	9	—	12	ns

**NOTES:**

- 0°C to +70°C temperature range only.
- This parameter guaranteed with AC load (Figure 3) by device characterization, but is not production tested.

2953 tbl 11

**TIMING WAVEFORM OF READ CYCLE NO. 1<sup>(1)</sup>**

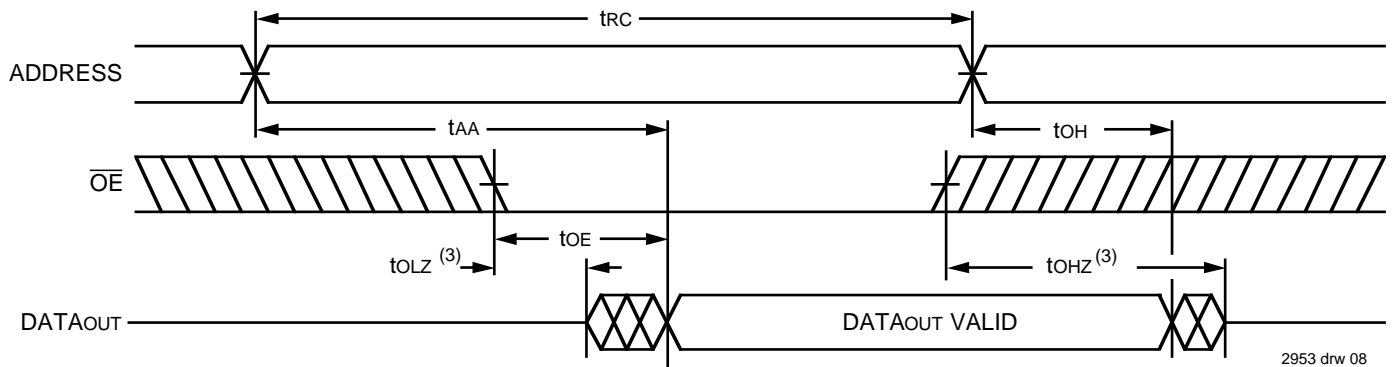

2953 drw 08

**TIMING WAVEFORM OF READ CYCLE NO. 2<sup>(1,2)</sup>**

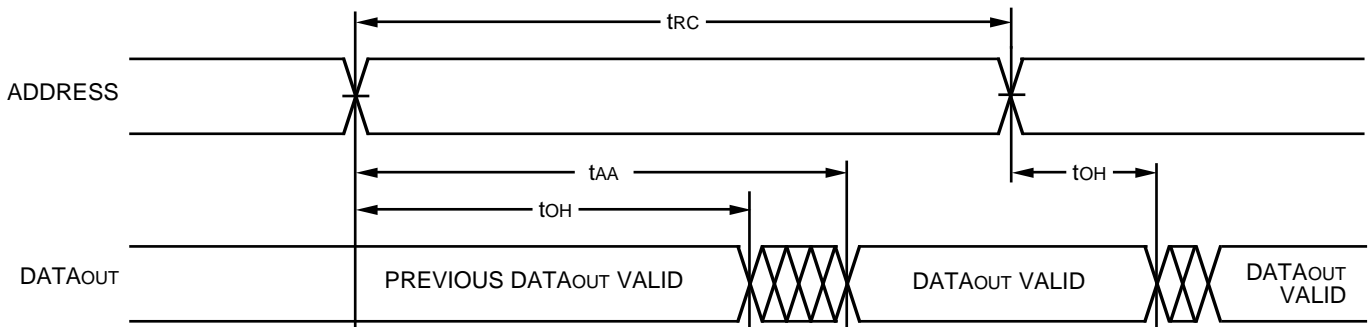

**NOTES:**

- $\overline{WE}$  is HIGH for Read Cycle.
- Output enable is continuously active,  $\overline{OE}$  is LOW.
- Transition is measured  $\pm 200V$  from steady state.

2953 drw 09

**AC ELECTRICAL CHARACTERISTICS** ( $V_{CC} = 5.0V \pm 10\%$ , All Temperature Ranges)

Symbol	Parameter	6178S10 <sup>(1)</sup>		6178S12		6178S15		6178S20/25		Unit
		Min.	Max.	Min.	Max.	Min.	Max.	Min.	Max.	
<b>Write Cycle</b>										
t <sub>WC</sub>	Write Cycle Time	10	—	12	—	15	—	20	—	ns
t <sub>AW</sub>	Address Valid to End-of-Write	8	—	10	—	12	—	14	—	ns
t <sub>AS</sub>	Address Set-up Time	0	—	0	—	0	—	0	—	ns
t <sub>WP</sub>	Write Pulse Width	8	—	10	—	12	—	14	—	ns
t <sub>WR</sub>	Write Recovery Time	0	—	0	—	0	—	0	—	ns
t <sub>DW</sub>	Data Valid to End-of-Write	6	—	8	—	10	—	12	—	ns
t <sub>DH</sub>	Data Hold from Write Time	0	—	0	—	0	—	0	—	ns
t <sub>WHZ</sub> <sup>(2)</sup>	Write Enable to Output in High-Z	—	5	—	6	—	7	—	9	ns
t <sub>OW</sub> <sup>(2)</sup>	Output Active from End-of-Write	0	—	0	—	0	—	0	—	ns

**NOTES:**

- 0°C to +70°C temperature range only.
- This parameter guaranteed with AC load (Figure 3) by device characterization, but is not production tested.

2953 tbl 12

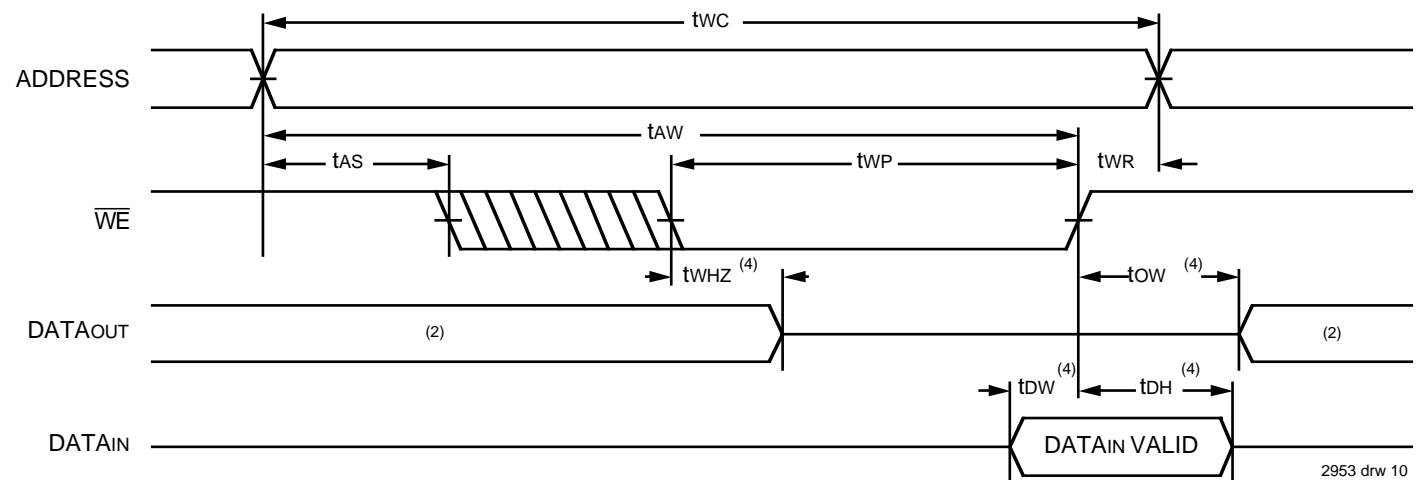
**TIMING WAVEFORM OF WRITE CYCLE**<sup>(1,3)</sup>

2953 drw 10

**NOTES:**

- $\overline{WE}$  must be HIGH during all address transitions.
- During this period, I/O pins are in the output state and the input signals must not be applied.
- $\overline{OE}$  is HIGH. If  $\overline{OE}$  is LOW during a  $\overline{WE}$  controlled write cycle, the write pulse width must be the greater of t<sub>WP</sub> or (t<sub>WHZ</sub> + t<sub>DW</sub>) to allow the I/O drivers to turn off and data to be placed on the bus for the required t<sub>DW</sub>. If  $\overline{OE}$  is HIGH during a  $\overline{WE}$  controlled write cycle, this requirement does not apply and the write pulse is the specified t<sub>WP</sub>.
- Transition is measured  $\pm 200mV$  from steady state.

**AC ELECTRICAL CHARACTERISTICS** ( $V_{CC} = 5.0V \pm 10\%$ , All Temperature Ranges)

Symbol	Parameter	6178S10 <sup>(1)</sup>		6178S12		6178S15		6178S20/25		Unit
		Min.	Max.	Min.	Max.	Min.	Max.	Min.	Max.	
<b>Clear Cycle</b>										
t <sub>CLPW</sub> <sup>(2)</sup>	$\overline{CLR}$ Pulse Width	12	—	15	—	20	—	25	—	ns
t <sub>CLRC</sub>	$\overline{CLR}$ HIGH to $\overline{WE}$ LOW	5	—	5	—	5	—	5	—	ns
t <sub>POCL</sub> <sup>(3)</sup>	Power on Reset	50	—	60	—	80	—	100	—	ns
t <sub>WECL</sub>	$\overline{WE}$ HIGH to Clear HIGH	5	—	5	—	5	—	5	—	ns

**NOTES:**

- 0°C to +70°C temperature range only.
- Recommended duty cycle of 10% maximum.
- This parameter guaranteed with AC load (Figure 3) by device characterization, but is not production tested.

2953 tbl 13

**TIMING WAVEFORM OF CLEAR CYCLE**

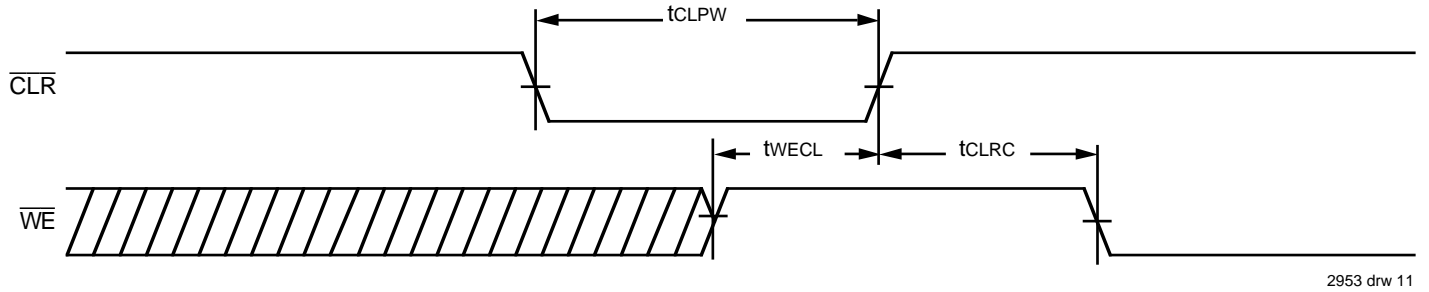

2953 drw 11

**POWER ON RESET TIMING**

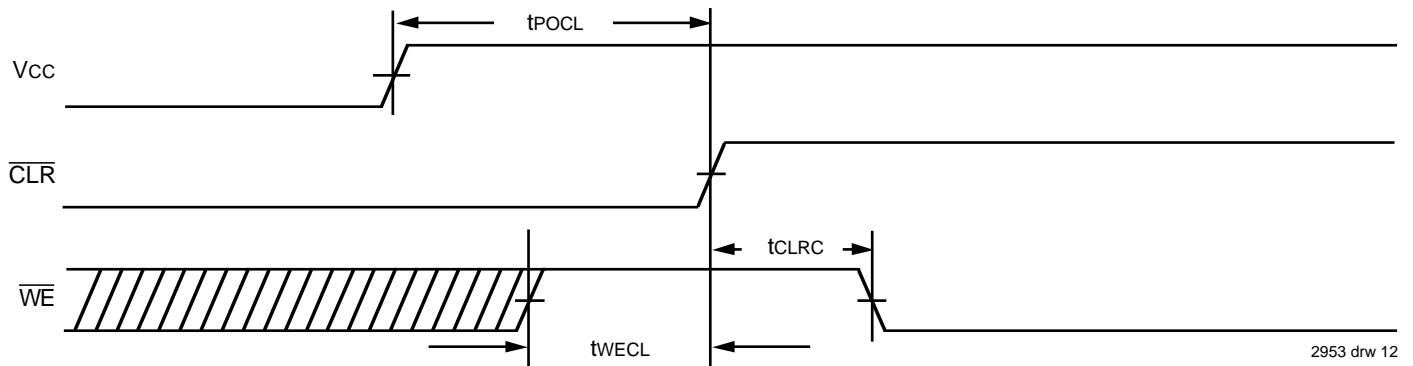

2953 drw 12

**ORDERING INFORMATION**

IDT	6178	S	XX	X	X	
	Device Type	Power	Speed	Package	Process/ Temperature	
					Blank B	Commercial (0°C to +70°C) Military (-55°C to +125°C, Compliant to MIL-STD-883, Class B)
					P Y D	300 mil Plastic DIP (P22-1) 300 mil Small Outline, J bend (SO24-4) 300 mil Ceramic DIP (D22-1)
					10 12 15 20 25	Commercial only
						} Speed in nanoseconds

2953 drw 13

This datasheet has been downloaded from:

[www.DatasheetCatalog.com](http://www.DatasheetCatalog.com)

Datasheets for electronic components.



LittleDiode supplies new, hard to find or obsolete electronic components and semiconductors all over the world.

With over two million different components listed you are sure to find the part you need.

Feel free to visit us today at our online store:

[LittleDiode.com](http://LittleDiode.com)

Looking forward to providing you with the best possible service.