

HD74AC166/HD74ACT166

8-bit Shift Register

HITACHI

Description

The HD74AC166/HD74ACT166 is an 8-bit, serial or parallel-in, serial-out shift register using edge triggered D-type flip-flops. Serial and parallel entry are synchronous, with state changes initiated by the rising edge of the clock. An asynchronous Master Reset overrides other inputs and clears all flip-flops. The circuit can be clocked from two sources or one CP input can be used to trigger the other.

Features

- Outputs Source/Sink 24 mA
- HD74ACT166 has TTL-Compatible Inputs

Pin Arrangement

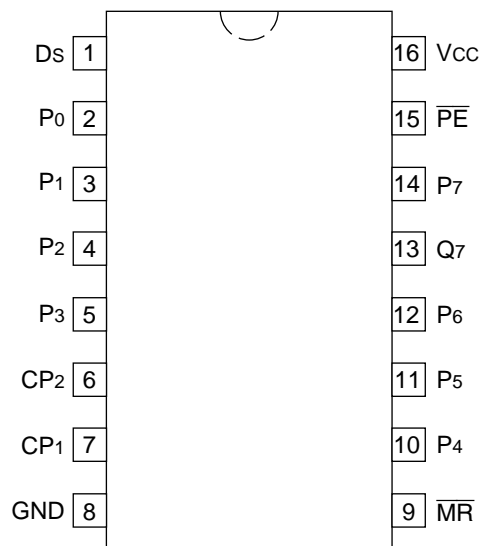

(Top view)

Logic Symbol

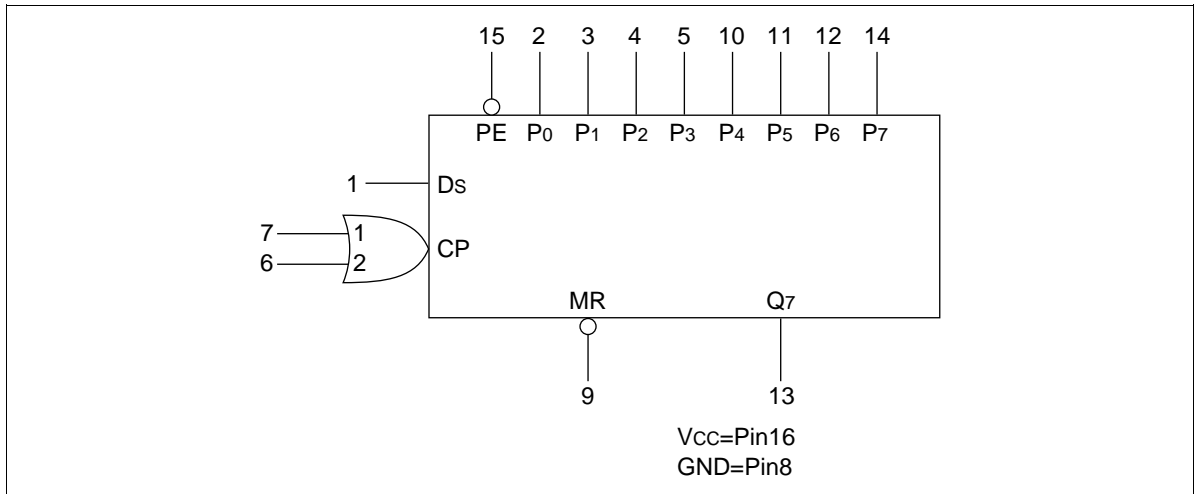

Pin Names

- CP₁, CP₂ Clock Pulse Inputs (Active Rising Edge)
- D_S Serial Data Input
- \overline{PE} Parallel Enable Input (Active Low)
- P₀ to P₇ Parallel Data Inputs
- \overline{MR} Asynchronous Master Reset Input (Active Low)
- Q₇ Last Stage Output

Functional Description

Operation is synchronous (except for Master Reset) and state changes are initiated by the rising edge of either clock input if the other clock input is Low. When one of the clock inputs is used as an active High clock inhibit, it should attain the High state while the other clock is still in the High state following the previous operation. When the Parallel Enable (\overline{PE}) input is Low, data is loaded into the register from the Parallel Data (P₀ to P₇) inputs on the next rising edge of the clock. When \overline{PE} is High, information is shifted from the Serial Data (D_S) input to Q₀ and all data in the register is shifted one bit position (i.e., Q₀ → Q₁, Q₁ → Q₂, etc.) on the rising edge of the clock.

Truth Table

Inputs

\overline{MR}	\overline{PE}	CP_2	CP_1	D_s	Parallel	Internal Outputs		Output
					P_0 to P_7	Q_0	Q_6	Q_7
L	X	X	X	X	X	L	L	L
H	X	L	L	X	X	Q_{A0}	Q_{B0}	Q_{H0}
H	L	L	\lrcorner	X	a ... h	a	b	h
H	H	L	\lrcorner	H	X	H	Q_{An}	Q_{Gn}
H	H	L	\lrcorner	L	X	L	Q_{An}	Q_{Gn}
H	X	H	\lrcorner	X	X	Q_{A0}	Q_{B0}	Q_{H0}

H : High Voltage Level

L : Low Voltage Level

X : Immaterial

\lrcorner : Low-to-High Clock Transition

Logic Diagram

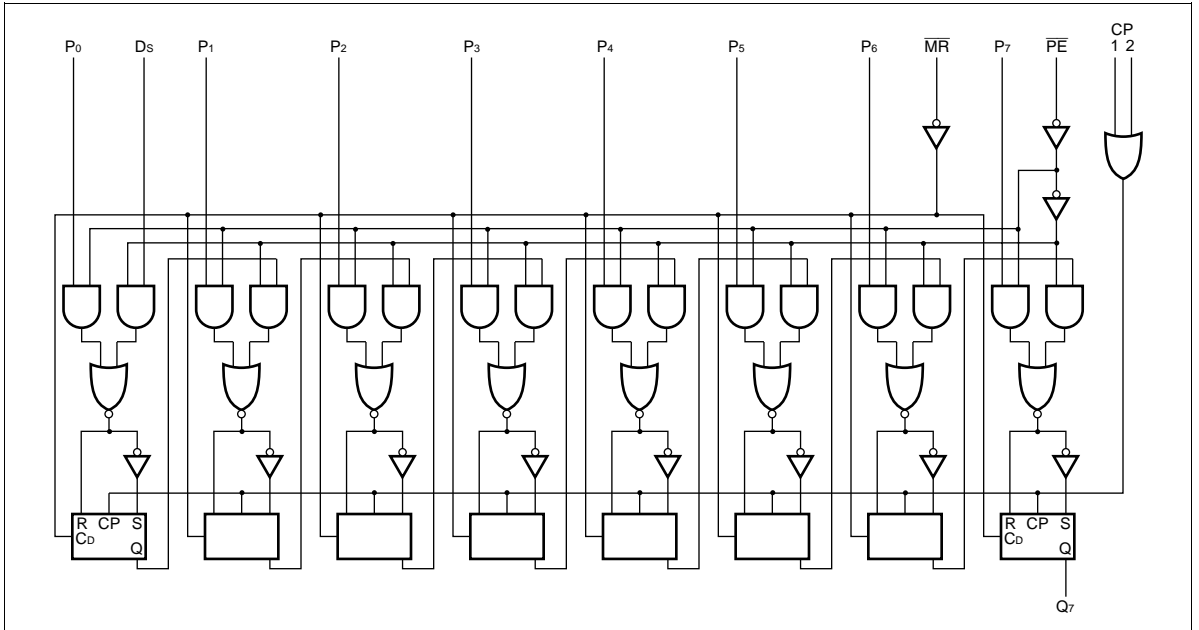

HD74AC166/HD74ACT166

DC Characteristics (unless otherwise specified)

Item	Symbol	Max	Unit	Condition
Maximum quiescent supply current	I_{CC}	80	μA	$V_{IN} = V_{CC}$ or ground, $V_{CC} = 5.5\text{ V}$, $T_a = \text{Worst case}$
Maximum quiescent supply current	I_{CC}	8.0	μA	$V_{IN} = V_{CC}$ or ground, $V_{CC} = 5.5\text{ V}$, $T_a = 25^\circ\text{C}$
Maximum additional I_{CC} /input (HD74ACT166)	I_{CCT}	1.5	mA	$V_{IN} = V_{CC} - 2.1\text{ V}$, $V_{CC} = 5.5\text{ V}$, $T_a = \text{Worst case}$

AC Characteristics: HD74AC166

Item	Symbol	$V_{CC} (\text{V})^{*1}$	$T_a = +25^\circ\text{C}$ $C_L = 50\text{ pF}$			$T_a = -40^\circ\text{C to } +85^\circ\text{C}$ $C_L = 50\text{ pF}$		Unit
			Min	Typ	Max	Min	Max	
Maximum clock frequency	f_{max}	3.3	75	—	—	65	—	MHz
		5.0	100	—	—	80	—	
Propagation delay CP_1 or CP_2 to Q_7	t_{PLH}	3.3	1.0	11.0	14.5	1.0	15.5	ns
		5.0	1.0	9.5	11.5	1.0	12.5	
Propagation delay CP_1 or CP_2 to Q_7	t_{PHL}	3.3	1.0	10.5	14.0	1.0	15.0	
		5.0	1.0	9.0	11.0	1.0	12.0	
Propagation delay \overline{MR} to Q_7	t_{PHL}	3.3	1.0	9.5	12.0	1.0	13.0	
		5.0	1.0	6.5	9.0	1.0	10.0	

Note: 1. Voltage Range 3.3 is $3.3\text{ V} \pm 0.3\text{ V}$
Voltage Range 5.0 is $5.0\text{ V} \pm 0.5\text{ V}$

AC Operating Requirements: HD74AC166

Item	Symbol	V _{CC} (V)* ¹	Ta = +25°C C _L = 50 pF		Ta = -40°C to +85°C C _L = 50 pF		Unit
			Typ	Guaranteed Minimum			
Setup time	t _{su}	3.3	3.0	5.5	6.0	ns	
\overline{PE} or P _n or D _s to CP _n		5.0	2.0	4.0	4.5		
Hold time	t _h	3.3	-1.5	3.0	3.0		
CP _n to \overline{PE} or P _n or D _s		5.0	-0.5	3.0	3.0		
Pulse width	t _w	3.3	2.0	5.5	7.0		
CP _n or \overline{MR}		5.0	2.0	4.5	5.0		
Recovery time	t _{rec}	3.3	-2.5	0.0	0.0		
\overline{MR} to CP _n		5.0	-1.5	0.0	0.0		

Note: 1. Voltage Range 3.3 is 3.3 V ± 0.3 V
Voltage Range 5.0 is 5.0 V ± 0.5 V

AC Characteristics: HD74ACT166

Item	Symbol	V _{CC} (V)* ¹	Ta = +25°C C _L = 50 pF			Ta = -40°C to +85°C C _L = 50 pF		Unit
			Min	Typ	Max	Min	Max	
Maximum clock frequency	f _{max}	5.0	100	—	—	80	—	MHz
Propagation delay CP _n to Q ₇	t _{PLH}	5.0	1.0	10.0	12.5	1.0	13.5	ns
Propagation delay CP _n to Q ₇	t _{PHL}	5.0	1.0	9.5	12.0	1.0	13.0	
Propagation delay \overline{MR} to Q ₇	t _{PHL}	5.0	1.0	8.5	11.0	1.0	12.0	

Note: 1. Voltage Range 5.0 is 5.0 V ± 0.5 V

HD74AC166/HD74ACT166

AC Operating Requirements: HD74ACT166

Item	Symbol	V_{CC} (V)*1	Ta = +25°C	Ta = -40°C		Unit
			$C_L = 50$ pF	to +85°C	$C_L = 50$ pF	
			Typ	Guaranteed Minimum		
Setup time \overline{PE} or P_n or D_S to CP_n	t_{su}	5.0	2.5	7.0	8.0	ns
Hold time CP_n to \overline{PE} or P_n or D_S	t_h	5.0	0.0	1.5	1.5	
Pulse width CP_n or \overline{MR}	t_w	5.0	4.5	7.0	8.0	
Recovery time \overline{MR} to CP_n	t_{rec}	5.0	-2.5	0.5	0.5	

Note: 1. Voltage Range 5.0 is $5.0\text{ V} \pm 0.5\text{ V}$

Capacitance

Item	Symbol	Typ	Unit	Condition
Input capacitance	C_{IN}	4.5	pF	$V_{CC} = 5.5\text{ V}$
Power dissipation capacitance	C_{PD}	35.0	pF	$V_{CC} = 5.0\text{ V}$

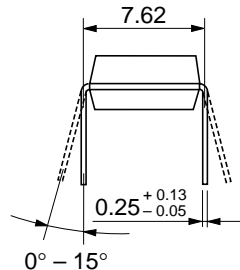
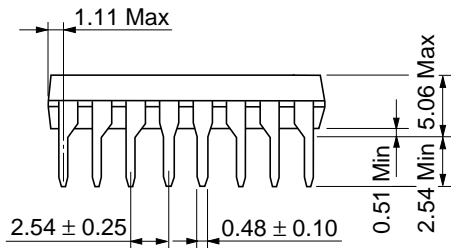
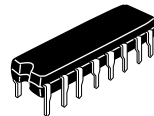
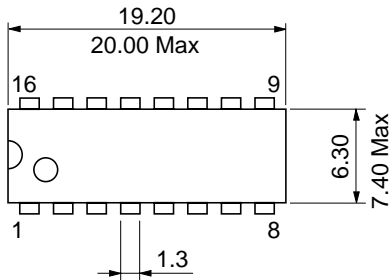

Hitachi Code	DP-16
JEDEC	Conforms
EIAJ	Conforms
Weight (reference value)	1.07 g

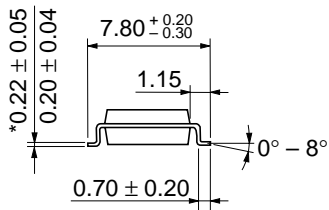
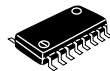
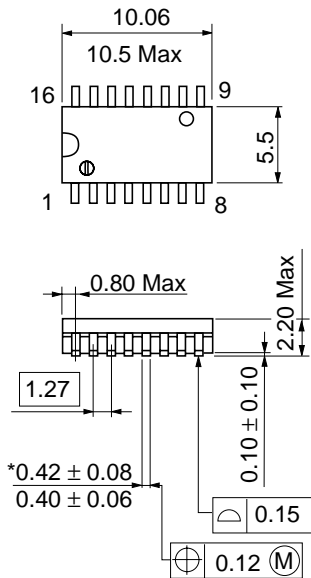

*Dimension including the plating thickness
 Base material dimension

Hitachi Code	FP-16DA
JEDEC	—
EIAJ	Conforms
Weight (reference value)	0.24 g

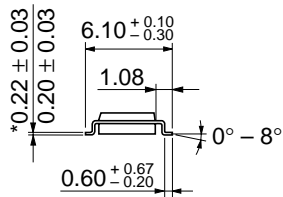
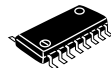
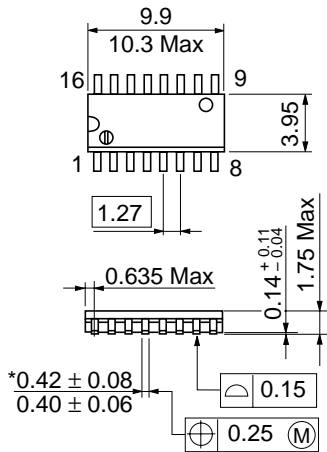

*Dimension including the plating thickness
Base material dimension

Hitachi Code	FP-16DN
JEDEC	Conforms
EIAJ	Conforms
Weight (reference value)	0.15 g

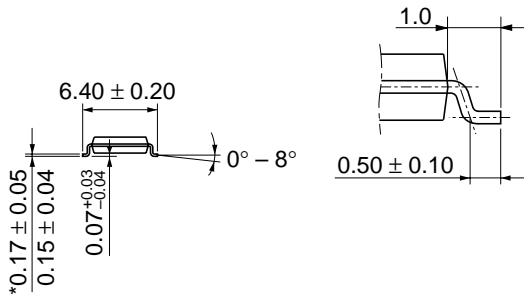
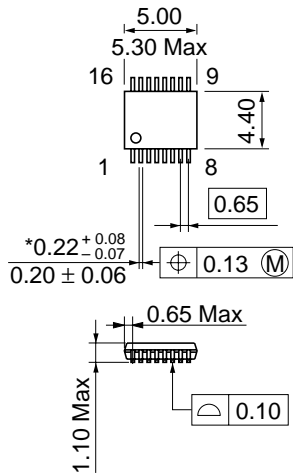

*Dimension including the plating thickness
 Base material dimension

Hitachi Code	TTP-16DA
JEDEC	—
EIAJ	—
Weight (reference value)	0.05 g

Cautions

1. Hitachi neither warrants nor grants licenses of any rights of Hitachi's or any third party's patent, copyright, trademark, or other intellectual property rights for information contained in this document. Hitachi bears no responsibility for problems that may arise with third party's rights, including intellectual property rights, in connection with use of the information contained in this document.
2. Products and product specifications may be subject to change without notice. Confirm that you have received the latest product standards or specifications before final design, purchase or use.
3. Hitachi makes every attempt to ensure that its products are of high quality and reliability. However, contact Hitachi's sales office before using the product in an application that demands especially high quality and reliability or where its failure or malfunction may directly threaten human life or cause risk of bodily injury, such as aerospace, aeronautics, nuclear power, combustion control, transportation, traffic, safety equipment or medical equipment for life support.
4. Design your application so that the product is used within the ranges guaranteed by Hitachi particularly for maximum rating, operating supply voltage range, heat radiation characteristics, installation conditions and other characteristics. Hitachi bears no responsibility for failure or damage when used beyond the guaranteed ranges. Even within the guaranteed ranges, consider normally foreseeable failure rates or failure modes in semiconductor devices and employ systemic measures such as fail-safes, so that the equipment incorporating Hitachi product does not cause bodily injury, fire or other consequential damage due to operation of the Hitachi product.
5. This product is not designed to be radiation resistant.
6. No one is permitted to reproduce or duplicate, in any form, the whole or part of this document without written approval from Hitachi.
7. Contact Hitachi's sales office for any questions regarding this document or Hitachi semiconductor products.

HITACHI

Hitachi, Ltd.

Semiconductor & Integrated Circuits.
Nippon Bldg., 2-6-2, Ohte-machi, Chiyoda-ku, Tokyo 100-0004, Japan
Tel: Tokyo (03) 3270-2111 Fax: (03) 3270-5109

URL North America : <http://semiconductor.hitachi.com/>
Europe : <http://www.hitachi-eu.com/hel/ecg>
Asia (Singapore) : <http://www.has.hitachi.com.sg/grp3/sicd/index.htm>
Asia (Taiwan) : http://www.hitachi.com.tw/E/Product/SICD_Frame.htm
Asia (HongKong) : <http://www.hitachi.com.hk/eng/bo/grp3/index.htm>
Japan : <http://www.hitachi.co.jp/Sicd/indx.htm>

For further information write to:

Hitachi Semiconductor
(America) Inc.
179 East Tasman Drive,
San Jose, CA 95134
Tel: <1> (408) 433-1990
Fax: <1> (408) 433-0223

Hitachi Europe GmbH
Electronic components Group
Dornacher Straße 3
D-85622 Feldkirchen, Munich
Germany
Tel: <49> (89) 9 9180-0
Fax: <49> (89) 9 29 30 00

Hitachi Europe Ltd.
Electronic Components Group.
Whitebrook Park
Lower Cookham Road
Maidenhead
Berkshire SL6 8YA, United Kingdom
Tel: <44> (1628) 585000
Fax: <44> (1628) 778322

Hitachi Asia Pte. Ltd.
16 Collyer Quay #20-00
Hitachi Tower
Singapore 049318
Tel: 535-2100
Fax: 535-1533

Hitachi Asia Ltd.
Taipei Branch Office
3F, Hung Kuo Building, No.167,
Tun-Hwa North Road, Taipei (105)
Tel: <886> (2) 2718-3666
Fax: <886> (2) 2718-8180

Hitachi Asia (Hong Kong) Ltd.
Group III (Electronic Components)
7/F., North Tower, World Finance Centre,
Harbour City, Canton Road, Tsim Sha Tsui,
Kowloon, Hong Kong
Tel: <852> (2) 735 9218
Fax: <852> (2) 730 0281
Telex: 40815 HITEC HX

Copyright ' Hitachi, Ltd., 1999. All rights reserved. Printed in Japan.

HITACHI



LittleDiode supplies new, hard to find or obsolete electronic components and semiconductors all over the world.

With over two million different components listed you are sure to find the part you need.

Feel free to visit us today at our online store:

LittleDiode.com

Looking forward to providing you with the best possible service.