

DN8643S

24-bit Shift Register Latch Driver IC

■ Overview

The DN8643S is an IC which incorporates a 24-bit shift register and a latch driver to meet high-speed operation, low power consumption and high-density printout of the thermal printers for the work processors, and so on. It employs the Bi-CMOS process in which the serial-in and serial-out/parallel-out functions are incorporated, the 24-step shift register block and latch block are composed of CMOS, and the 24-step parallel driver block is bipolar.

■ Features

- Serial-in and serial-out/parallel-out
- Cascade connection allowed
- Built-in output malfunctioning preventive circuit
- Low current at standby $I_{CC} \leq 100\mu A$
- High-breakdown, large current drive type output steps
Breakdown : 30V
Output current : 120mA
- Surface mountable USONF-36D package (pin pitch : 0.8mm)

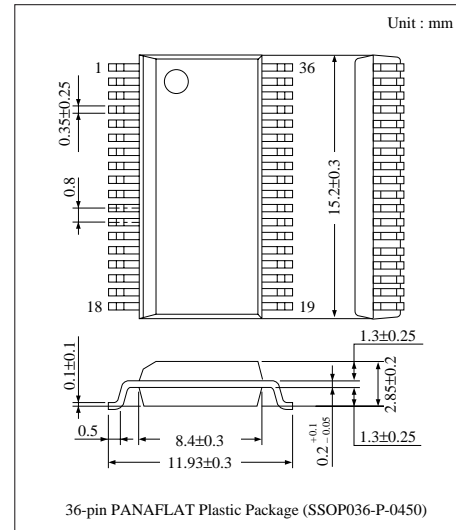

■ Block Diagram

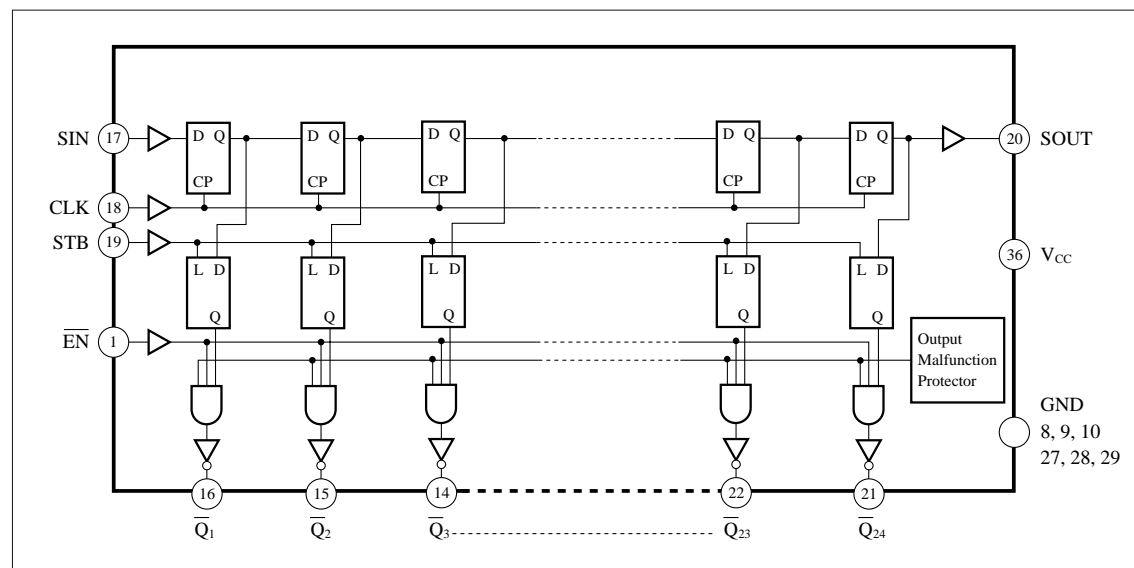

■ Absolute Maximum Ratings (Ta=25°C)

Parameter	Symbol	Rating	Unit
Supply voltage	V _{CC}	0 to 7	V
Output voltage	V _O	0 to 30	V
Output current	I _O	120	mA
Power dissipation	P _D	1.3 *	W
Operating ambient temperature	T _{opr}	-20 to + 75	°C
Storage temperature	T _{stg}	-55 to + 125	°C

* When mounting onto the PCB, power dissipation is reduced at a rate of 10.4mW/°C from Ta=25°C

■ Recommended Operating Range (Ta=25°C)

Parameter	Symbol	Condition	min	typ	max	Unit
Supply voltage	V _{CC}		4	5	6	V
Output voltage	V _O		—	—	30	V
Output current *	I _O		—	—	100	mA
Clock frequency	f _{CLK}	Input Duty 40 to 60%	—	—	10	MHz
Input pulse width	CLK	t _w	40	—	—	ns
	STB		40	—	—	ns
Setup time	SIN	t _{su}	30	—	—	ns
	STB		40	—	—	ns
Hold time	SIN	t _h	20	—	—	ns
	STB		0	—	—	ns
Clock pulse rise time	t _r		—	—	500	ns
Clock pulse fall time	t _f		—	—	500	ns

* An allowable value changes depends on the number of simultaneously turned-on circuits and the duty. Use with power dissipation taken into full account.

■ Electrical Characteristics (Ta=25°C)

Parameter	Symbol	Condition	min	typ	max	Unit
Input voltage	V _{IH}	V _{CC} =4 to 6V	0.7V _{CC}	—	V _{CC}	V
	V _{IL}		0	—	0.3V _{CC}	V
Input current	I _{IH}	V _{IH} =5V	—	—	25	μA
	I _{IL}	V _{IL} =0V	—	—	-25	μA
Output voltage	V _{OH}	I _O =-1μA	4.9	—	—	V
	V _{OL}	I _O =1μA	—	—	0.1	V
Output current	I _{OH}	V _{OH} =4.5V	-4	—	—	mA
	I _{OL}	V _{OL} =0.4V	4	—	—	mA
Output saturation voltage	V _{CE(sat)1}	I _{OL} =100mA	—	—	0.4	V
	V _{CE(sat)2}	I _{OL} =80mA	—	—	0.35	V
Output leakage current	I _{OLK1}	V _O =30V (output OFF)	—	—	50	μA
	I _{OLK2}	V _O =15V (output Off)	—	—	25	μA
Supply current	I _{CC1}	Total driver output OFF	—	—	100	μA
	I _{CC2}	Driver output 1 circuit ON	—	—	5	mA
Output malfunctioning preventive circuit operating voltage *	V _{CCT+}		2.9	—	3.9	V
	V _{CCT-}		2.6	—	3.6	V

* Output malfunctioning preventive circuit operating voltage timing chart

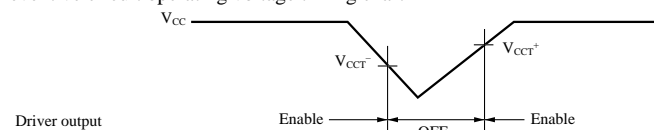

■ Switching Characteristics (Ta=25°C)

Parameter	Symbol	Input	Output	Condition	min	typ	max	Unit
Maximum clock frequency	f_{max}	CLK			10	—	—	MHz
Propagation delay time	t_{PLH}	CLK	SOUT	$V_{CC}=5V$ $C_L=15pF$	—	—	100	ns
	t_{PHL}				—	—	100	ns
	t_{PLH}	CLK	$\bar{Q}n$	$V_{CC}=5V$ $R_L=100\Omega$	—	—	2	μs
	t_{PHL}				—	—	0.5	μs
	t_{PLH}	\bar{EN}	$\bar{Q}n$	$C_L=15pF$	—	—	2	μs
	t_{PHL}				—	—	0.5	μs

■ Timing Chart

1. Input Timing

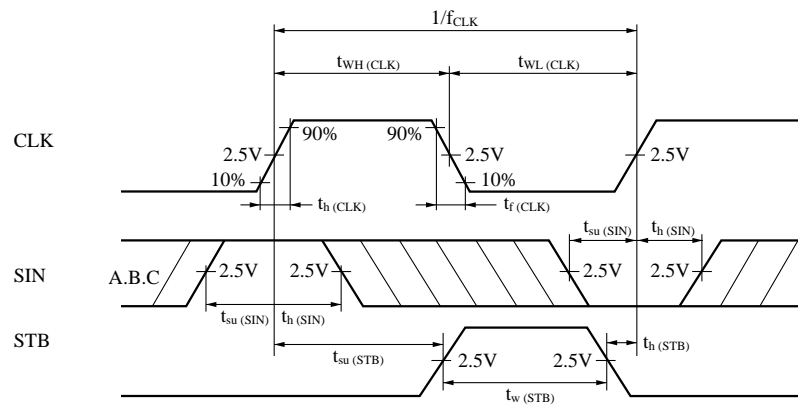

2. Propagation Delay Time

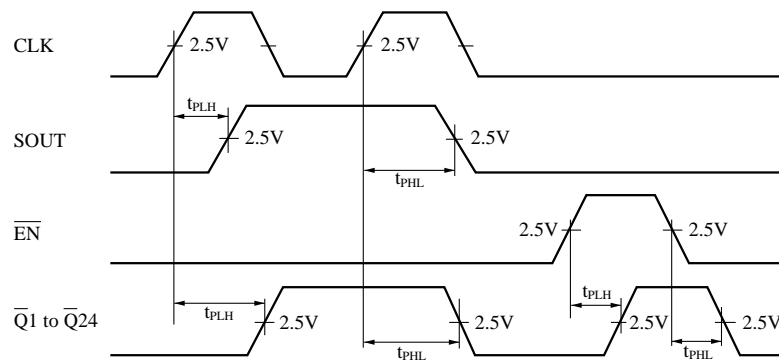

■ Pin Assignments

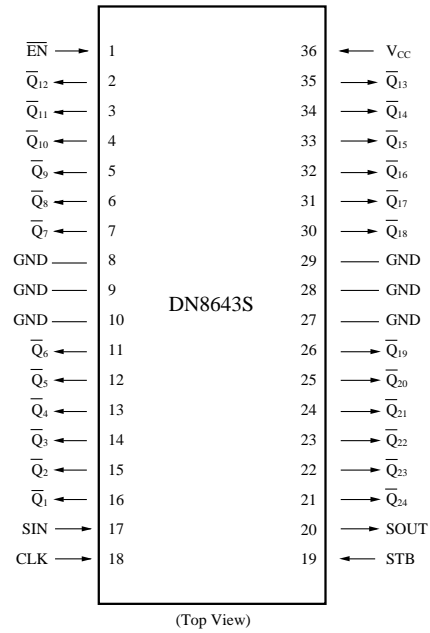

■ Functions Table

Input				Driver output		SOUT
CLK	\overline{EN}	STB	SIN	\overline{Q}_1	\overline{Q}_n	
↑	H	×	×	H	H	Q'_{23}
↓	H	×	×	H	H	nc
↑	L	L	×	nc	nc	Q'_{23}
↑	L	H	L	H	\overline{Q}_{n-1}	Q'_{23}
↑	L	H	H	L	\overline{Q}_{n-1}	Q'_{23}
↓	L	H	×	nc	nc	nc

Note) H=High level, L=Low level, × = Either "H" or "L" will do, ↑ = Transition from "H" or "L", ↓ = Transition from "H" to "L", nc=No change, Q'_{23} =Status of the 23rd shift register

Request for your special attention and precautions in using the technical information and semiconductors described in this material

- (1) An export permit needs to be obtained from the competent authorities of the Japanese Government if any of the products or technologies described in this material and controlled under the "Foreign Exchange and Foreign Trade Law" is to be exported or taken out of Japan.
- (2) The technical information described in this material is limited to showing representative characteristics and applied circuit examples of the products. It does not constitute the warranting of industrial property, the granting of relative rights, or the granting of any license.
- (3) The products described in this material are intended to be used for standard applications or general electronic equipment (such as office equipment, communications equipment, measuring instruments and household appliances).
Consult our sales staff in advance for information on the following applications:
 - Special applications (such as for airplanes, aerospace, automobiles, traffic control equipment, combustion equipment, life support systems and safety devices) in which exceptional quality and reliability are required, or if the failure or malfunction of the products may directly jeopardize life or harm the human body.
 - Any applications other than the standard applications intended.
- (4) The products and product specifications described in this material are subject to change without notice for reasons of modification and/or improvement. At the final stage of your design, purchasing, or use of the products, therefore, ask for the most up-to-date Product Standards in advance to make sure that the latest specifications satisfy your requirements.
- (5) When designing your equipment, comply with the guaranteed values, in particular those of maximum rating, the range of operating power supply voltage and heat radiation characteristics. Otherwise, we will not be liable for any defect which may arise later in your equipment.
Even when the products are used within the guaranteed values, redundant design is recommended, so that such equipment may not violate relevant laws or regulations because of the function of our products.
- (6) When using products for which dry packing is required, observe the conditions (including shelf life and after-unpacking standby time) agreed upon when specification sheets are individually exchanged.
- (7) No part of this material may be reprinted or reproduced by any means without written permission from our company.

Please read the following notes before using the datasheets

- A. These materials are intended as a reference to assist customers with the selection of Panasonic semiconductor products best suited to their applications.
Due to modification or other reasons, any information contained in this material, such as available product types, technical data, and so on, is subject to change without notice.
Customers are advised to contact our semiconductor sales office and obtain the latest information before starting precise technical research and/or purchasing activities.
- B. Panasonic is endeavoring to continually improve the quality and reliability of these materials but there is always the possibility that further rectifications will be required in the future. Therefore, Panasonic will not assume any liability for any damages arising from any errors etc. that may appear in this material.
- C. These materials are solely intended for a customer's individual use.
Therefore, without the prior written approval of Panasonic, any other use such as reproducing, selling, or distributing this material to a third party, via the Internet or in any other way, is prohibited.



LittleDiode supplies new, hard to find or obsolete electronic components and semiconductors all over the world.

With over two million different components listed you are sure to find the part you need.

Feel free to visit us today at our online store:

LittleDiode.com

Looking forward to providing you with the best possible service.