

SIM Card EMI Filter Array with ESD Protection

Features

- Functionally and pin compatible with CMD's CSPEMI400
- Optiguard™ coated for improved reliability at assembly
- Three channels of EMI filtering, each with ESD protection
- Two additional channels of ESD-only protection
- ±10kV ESD protection (IEC 61000-4-2, contact discharge) on all pins
- ±25kV ESD protection (HBM)
- Greater than 30dB of attenuation at 1GHz
- 10-bump, 1.960mm x 1.330mm footprint Chip Scale Package (CSP)
- Chip Scale Package features extremely low lead inductance for optimum filter and ESD performance
- Lead-free version available

Applications

- SIM Card slot in mobile handsets
- I/O port protection for mobile handsets, notebook computers, PDAs, etc.
- EMI filtering for data ports in cell phones, PDAs or notebook computers

Product Description

CAMD's CM1402 is an EMI filter array with ESD protection, which integrates three pi filters (C-R-C) and two additional channels of ESD protection. The CM1402 has component values of 20pF-47Ω-20pF, and 20pF-100Ω-20pF. The parts include avalanche-type ESD diodes on every pin, which provide a very high level of protection for sensitive electronic components that may be subjected to electrostatic discharge (ESD). The ESD diodes connected to the filter ports are designed and characterized to safely dissipate ESD strikes of ±10kV, beyond the maximum requirement of the IEC 61000-4-2 international standard. Using the MIL-STD-883 (Method 3015) specification for Human Body Model (HBM) ESD, the pins are protected for contact discharges at greater than ±25kV.

The ESD diodes on pins A4 and C4 ports are designed and characterized to safely dissipate ESD strikes of ±10kV, well beyond the maximum requirement of the IEC 61000-4-2 international standard.

This device is particularly well suited for portable electronics (e.g. mobile handsets, PDAs, notebook computers) because of its small package format and easy-to-use pin assignments. In particular, the CM1402 is ideal for EMI filtering and protecting data lines from ESD for the SIM card slot in mobile handsets.

The CM1402 incorporates Optiguard™ coating which results in improved reliability at assembly. The CM1402 is available in a space-saving, low-profile Chip Scale Package with optional lead-free finishing.

Electrical Schematic

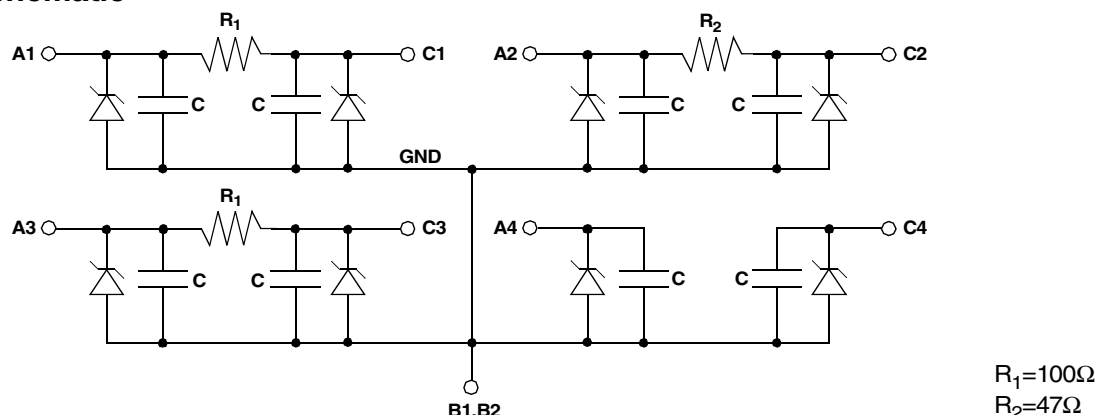

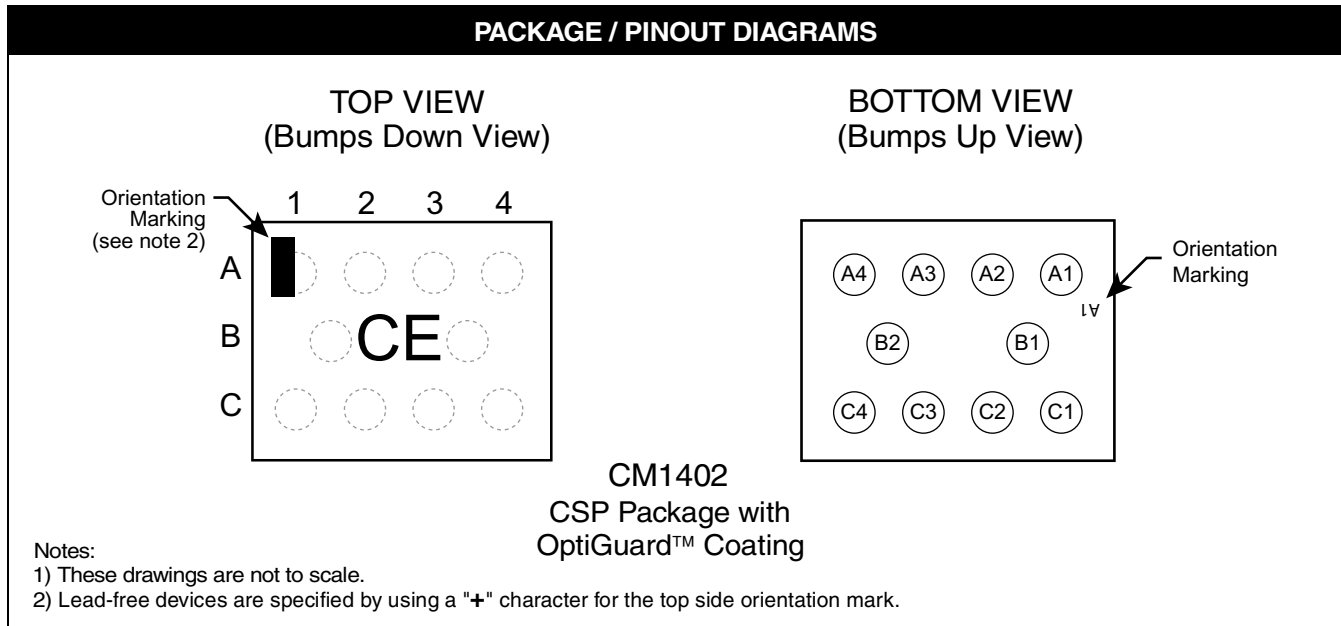
PACKAGE / PINOUT DIAGRAMS

PIN DESCRIPTIONS

TYPE	PIN	DESCRIPTION
EMI Filter	A1	EMI Filter with ESD Protection for RST Signal
	C1	EMI Filter with ESD Protection for RST Signal
EMI Filter	A2	EMI Filter with ESD Protection for CLK Signal
	C2	EMI Filter with ESD Protection for CLK Signal
Device Ground	B1	Device Ground
	B2	Device Ground
EMI Filter	A3	EMI Filter with ESD Protection for DAT Signal
	C3	EMI Filter with ESD Protection for DAT Signal
ESD Channel	A4	ESD Protection Channel - V_{CC} Supply
ESD Channel	C4	ESD Protection Channel

Ordering Information
PART NUMBERING INFORMATION

Bumps	Package	Standard Finish		Lead-free Finish ²	
		Ordering Part Number ¹	Part Marking	Ordering Part Number ¹	Part Marking
10	CSP	CM1402-03CS	CE	CM1402-03CP	CE

Note 1: Parts are shipped in Tape & Reel form unless otherwise specified.

Note 2: Lead-free devices are specified by using a "+" character for the top side orientation mark.

Specifications

ABSOLUTE MAXIMUM RATINGS

PARAMETER	RATING	UNITS
Storage Temperature Range	-65 to +150	°C
DC Power per Resistor	100	mW
DC Package Power Rating	300	mW

STANDARD OPERATING CONDITIONS

PARAMETER	RATING	UNITS
Operating Temperature Range	-40 to +85	°C

ELECTRICAL OPERATING CHARACTERISTICS¹

SYMBOL	PARAMETER	CONDITIONS	MIN	TYP	MAX	UNITS
R ₁	Resistance of R ₁		80	100	120	Ω
R ₂	Resistance of R ₂		38	47	56	Ω
C	Capacitance	V _{IN} = 2.5VDC, 1MHz, 30mV ac	16	20	24	pF
V _{STANDOFF}	Stand-off Voltage	I = 10μA	5.5			V
I _{LEAK}	Diode Leakage Current	V _{BIAS} = 3.3V		100		nA
V _{SIG}	Signal Voltage					
	Positive Clamp	I _{LOAD} = 10mA	5.6	6.8	9.0	V
	Negative Clamp	I _{LOAD} = -10mA	-1.5	-0.8	-0.4	V
V _{ESD}	In-system ESD Withstand Voltage	Notes 2,4 and 5				
	a) Human Body Model, MIL-STD-883, Method 3015		±25			kV
	b) Contact Discharge per IEC 61000-4-2		±10			kV
V _{CL}	Clamping Voltage during ESD Discharge	Notes 2,3,4 and 5				
	MIL-STD-883 (Method 3015), 8kV					
	Positive Transients				+12	V
	Negative Transients				-7	V
f _{C1}	Cut-off frequency	R = 100Ω, C = 20pF		77		MHz
	Z _{SOURCE} = 50Ω, Z _{LOAD} = 50Ω					
f _{C2}	Cut-off frequency	R = 47Ω, C = 20pF		85		MHz
	Z _{SOURCE} = 50Ω, Z _{LOAD} = 50Ω					

Note 1: T_A=25°C unless otherwise specified.

Note 2: ESD applied to input and output pins with respect to GND, one at a time.

Note 3: Clamping voltage is measured at the opposite side of the EMI filter to the ESD pin. For example, if ESD is applied to Pin A1, then clamping voltage is measured at Pin C1.

Note 4: Unused pins are left open

Note 5: The parameters are guaranteed by design.

Performance Information

Typical Filter Performance (nominal conditions unless specified otherwise, 50 Ohm Environment)

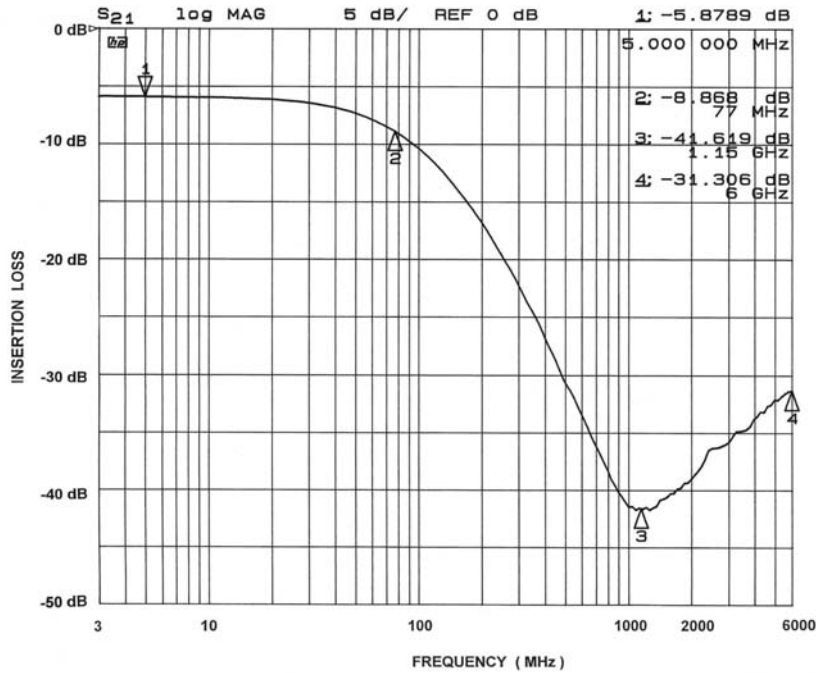

Figure 1. A1-C1 EMI Filter Performance

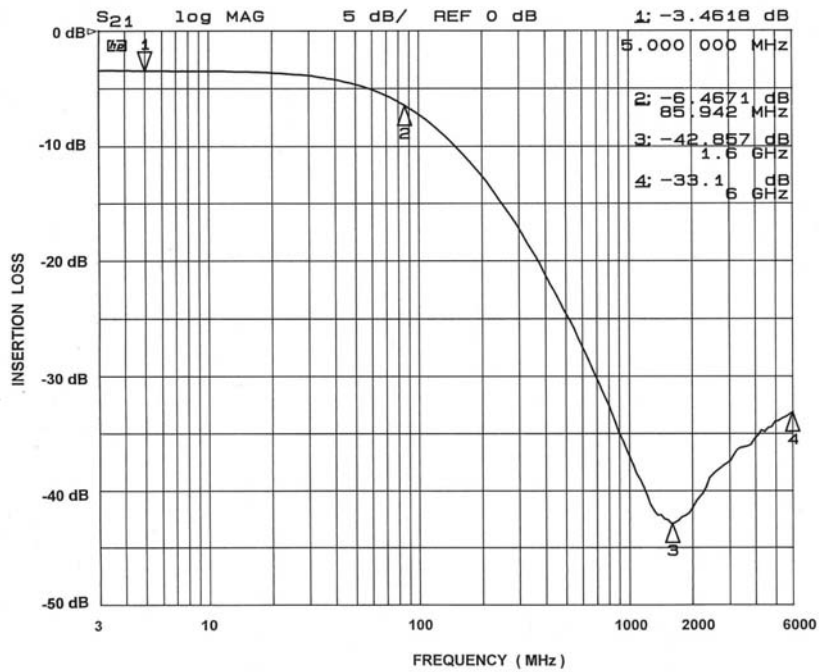

Figure 2. A2-C2 EMI Filter Performance

Performance Information (cont'd)

Typical Filter Performance (nominal conditions unless specified otherwise, 50 Ohm Environment)

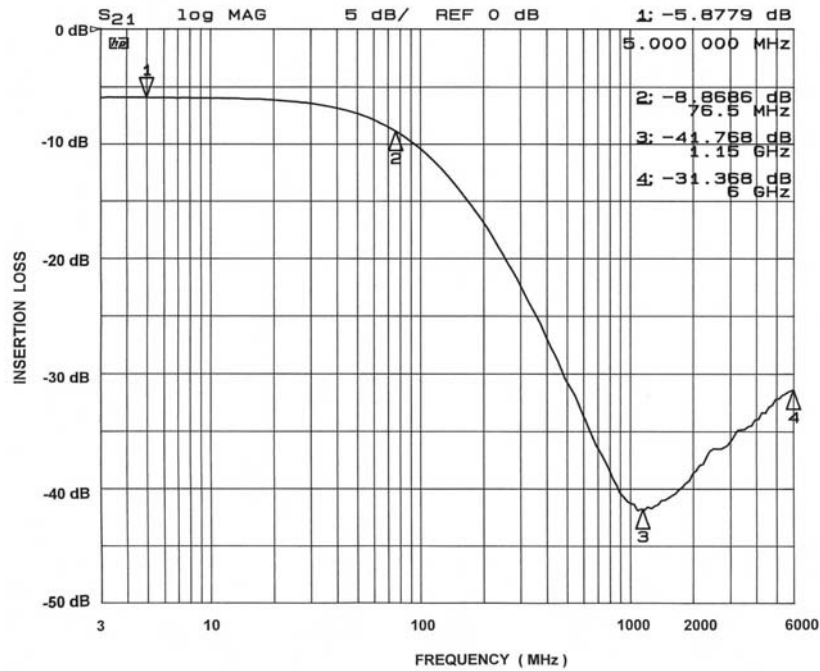

Figure 3. A3-C3 EMI Filter Performance

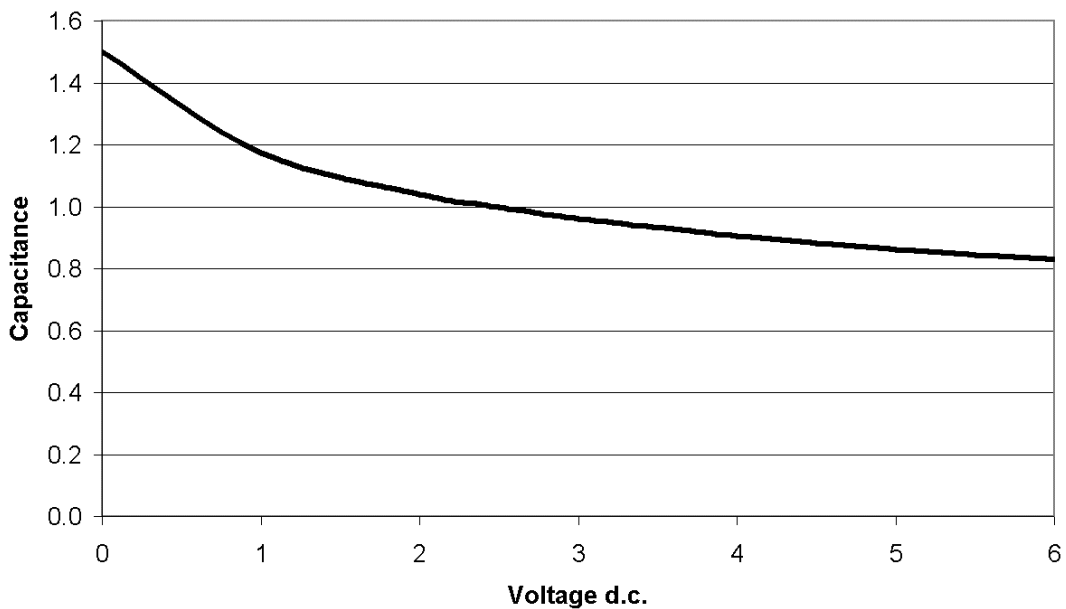
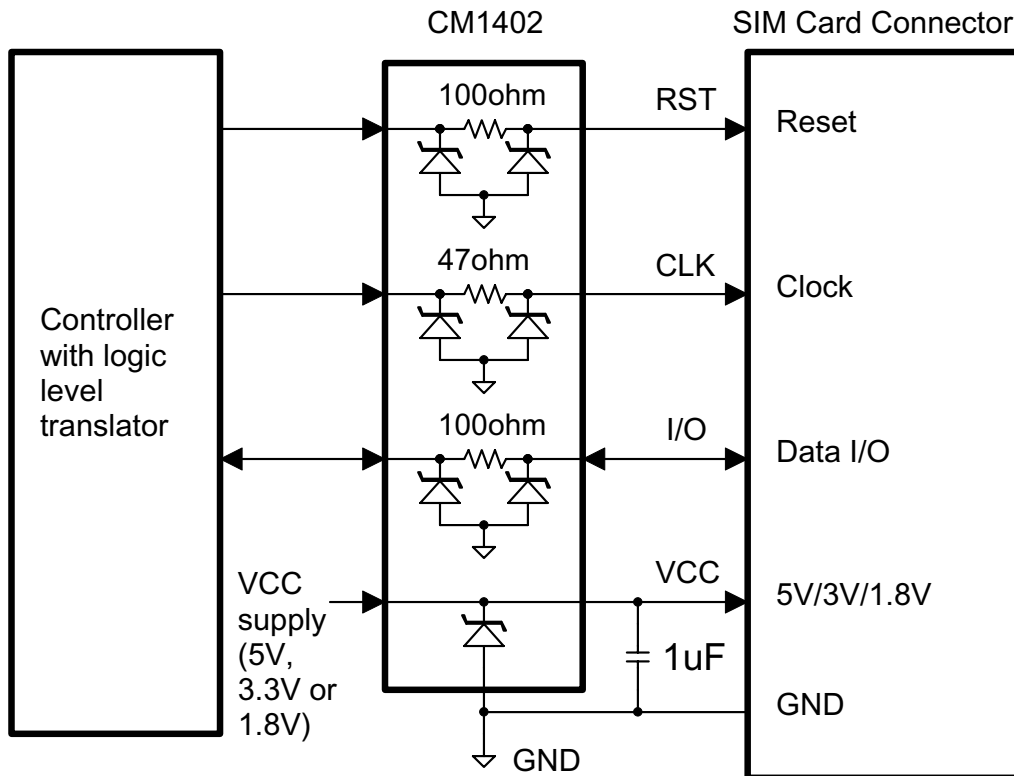

Figure 4. Typical Diode Capacitance vs. Input Voltage (normalized to 2.5VDC)

Application Information

The CM1402 provides a bidirectional filter and protector for all the signals and the power line on the SIM (subscriber identity module) card connector. SIM cards are found in all GSM cellular phones and in some other handheld devices or card readers. The ESD diodes protect the controller against possible ESD strikes that may occur when the connector pins are exposed during direct con-

tact, or during insertion of the SIM card into the card slot. The EMI filter suppresses all high-frequency noise, preventing the unwanted EMI signals from both entering and exiting the main board. The signals that interface with the SIM card are the Reset, the Clock and the bidirectional data I/O, as shown in Figure 5.



Note: One channel of the CM1402 with a zener diode is not shown on the diagram.

Figure 5. Typical Application Diagram for the SIM Card Interface

For best filter and ESD performance, both GND bumps (B1, B2) of the CM1402 should be directly connected to the Ground plane. A small capacitor of about 1µF is required next to the V_{CC} pin of the SIM connector in order to improve stability of the SIM card supply rail.

For information on the assembly of the CM1402 to the PCB (printed circuit board), please refer to the Chip Scale Package (CSP) Application Note AP217, or contact factory at 800-325-4966 for technical support.

Application Information (cont'd)

Refer to Application Note AP-217, "The Chip Scale Package", for a detailed description of Chip Scale Packages offered by California Micro Devices.

PRINTED CIRCUIT BOARD RECOMMENDATIONS	
PARAMETER	VALUE
Pad Size on PCB	0.275mm Round
Pad Definition	Non-Solder Mask defined pads
Solder Mask Opening	0.325mm Round
Solder Stencil Thickness	0.125 - 0.150mm
Solder Stencil Aperture Opening (laser cut, 5% tapered walls)	0.330mm Round
Solder Flux Ratio	50/50 by volume
Solder Paste Type	No Clean
Pad Protective Finish	OSP (Entek Cu Plus 106A)
Tolerance — Edge To Corner Ball	±50µm
Solder Ball Side Coplanarity	±20µm
Maximum Dwell Time Above Liquidous	60 seconds
Soldering Maximum Temperature	260°C

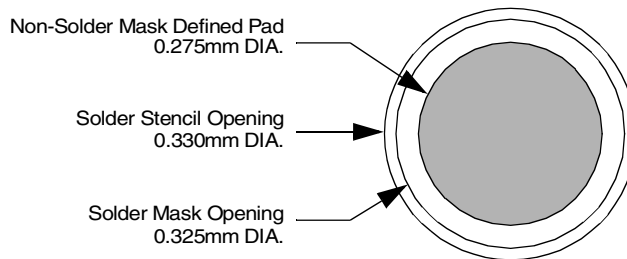

Figure 6. Recommended Non-Solder Mask Defined Pad Illustration

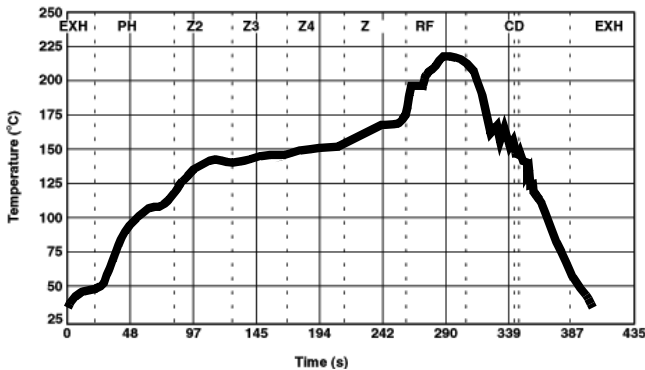

Figure 7. Eutectic (SnPb) Solder Ball Reflow Profile

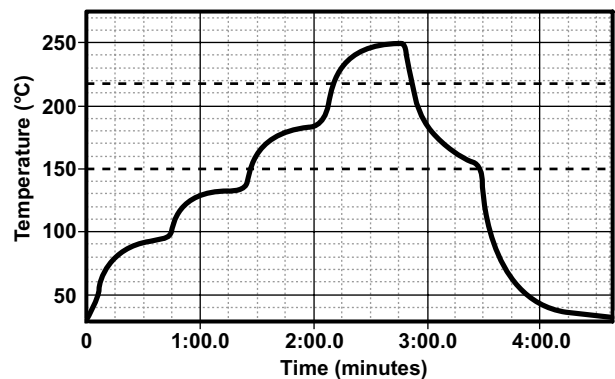
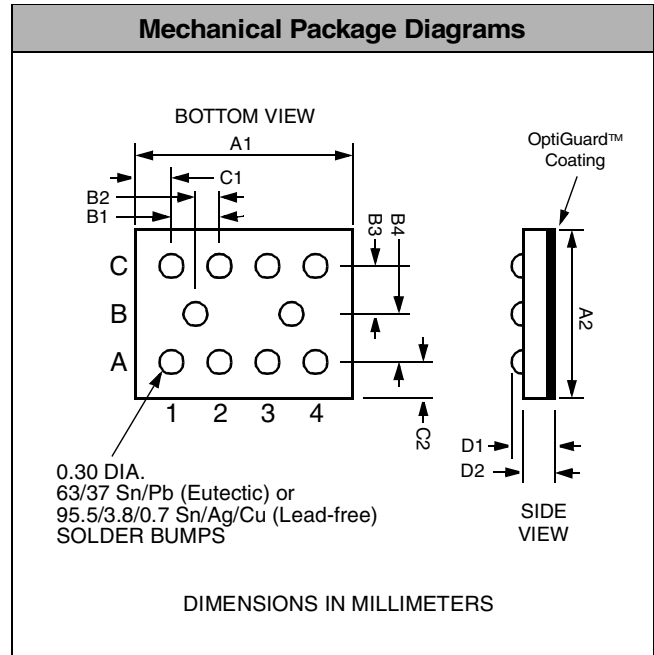

Figure 8. Lead-free (SnAgCu) Solder Ball Reflow Profile

CSP Mechanical Specifications

CM1402 devices are packaged in a custom Chip Scale Package (CSP). Dimensions are presented below. For complete information on CSP packaging, see the California Micro Devices CSP Package Information document.

PACKAGE DIMENSIONS						
Package	Custom CSP					
Bumps	10					
Dim	Millimeters			Inches		
	Min	Nom	Max	Min	Nom	Max
A1	1.915	1.960	2.005	0.0754	0.0772	0.0789
A2	1.285	1.330	1.375	0.0506	0.0524	0.0541
B1	0.495	0.500	0.505	0.0195	0.0197	0.0199
B2	0.245	0.250	0.255	0.0096	0.0098	0.0100
B3	0.430	0.435	0.440	0.0169	0.0171	0.0173
B4	0.430	0.435	0.440	0.0169	0.0171	0.0173
C1	0.180	0.230	0.280	0.0071	0.0091	0.0110
C2	0.180	0.230	0.280	0.0071	0.0091	0.0110
D1	0.600	0.670	0.739	0.0236	0.0264	0.0291
D2	0.394	0.445	0.495	0.0155	0.0175	0.0195
# per tape and reel	3500 pieces					
Controlling dimension: millimeters						



Package Dimensions for CM1402 Chip Scale Package

CSP Tape and Reel Specifications

PART NUMBER	CHIP SIZE (mm)	POCKET SIZE (mm) $B_0 \times A_0 \times K_0$	TAPE WIDTH W	REEL DIAMETER	QTY PER REEL	P_0	P_1
CM1402	1.96 X 1.33 X 0.6	2.08 X 1.45 X 0.71	8mm	178mm (7")	3500	4mm	4mm

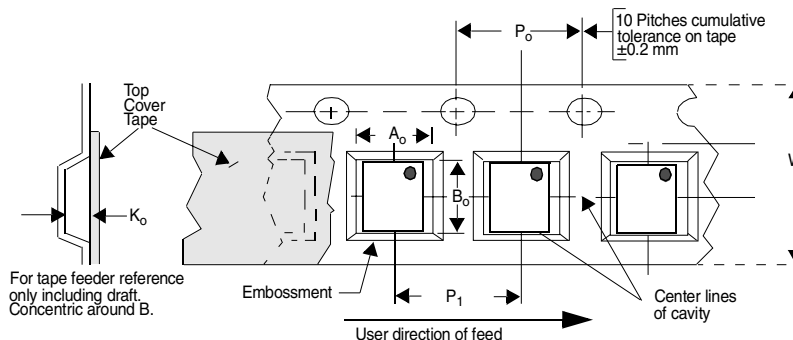

Figure 9. Tape and Reel Mechanical Data



LittleDiode supplies new, hard to find or obsolete electronic components and semiconductors all over the world.

With over two million different components listed you are sure to find the part you need.

Feel free to visit us today at our online store:

LittleDiode.com

Looking forward to providing you with the best possible service.