



Integrated Device Technology, Inc.

CMOS ASYNCHRONOUS FIFO

256 x 9, 512 x 9, 1K x 9

IDT7200L
IDT7201LA
IDT7202LA

FEATURES:

- First-In/First-Out dual-port memory
- 256 x 9 organization (IDT7200)
- 512 x 9 organization (IDT7201)
- 1K x 9 organization (IDT7202)
- Low power consumption
 - Active: 770mW (max.)
 - Power-down: 2.75mW (max.)
- Ultra high speed—12ns access time
- Asynchronous and simultaneous read and write
- Fully expandable by both word depth and/or bit width
- Pin and functionally compatible with 720X family
- Status Flags: Empty, Half-Full, Full
- Auto-retransmit capability
- High-performance CEMOS™ technology
- Military product compliant to MIL-STD-883, Class B
- Standard Military Drawing #5962-87531, 5962-89666, 5962-89863 and 5962-89536 are listed on this function
- Industrial temperature range (-40oC to +85oC) is available, tested to military electrical specifications

DESCRIPTION:

The IDT7200/7201/7202 are dual-port memories that load and empty data on a first-in/first-out basis. The devices use Full and Empty flags to prevent data overflow and underflow and expansion logic to allow for unlimited expansion capability in both word size and depth.

The reads and writes are internally sequential through the use of ring pointers, with no address information required to load and unload data. Data is toggled in and out of the devices through the use of the Write (\bar{W}) and Read (\bar{R}) pins.

The devices utilizes a 9-bit wide data array to allow for control and parity bits at the user's option. This feature is especially useful in data communications applications where it is necessary to use a parity bit for transmission/reception error checking. It also features a Retransmit (\bar{RT}) capability that allows for reset of the read pointer to its initial position when \bar{RT} is pulsed low to allow for retransmission from the beginning of data. A Half-Full Flag is available in the single device mode and width expansion modes.

The IDT7200/7201/7202 are fabricated using IDT's high-speed CMOS technology. They are designed for those applications requiring asynchronous and simultaneous read/writes in multiprocessing and rate buffer applications. Military grade product is manufactured in compliance with the latest revision of MIL-STD-883, Class B.

FUNCTIONAL BLOCK DIAGRAM

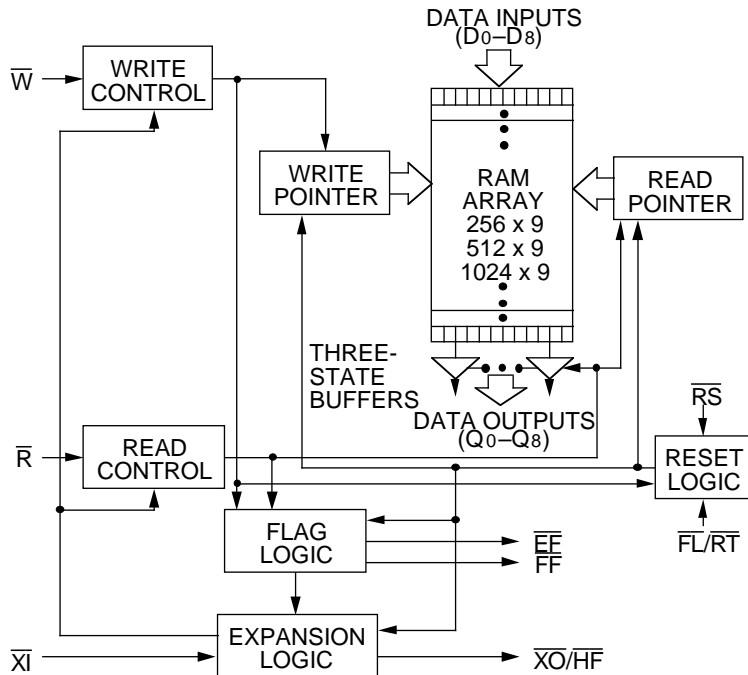

The IDT logo is a trademark of Integrated Device Technology, Inc.

MILITARY AND COMMERCIAL TEMPERATURE RANGES

DECEMBER 1996

PIN CONFIGURATIONS

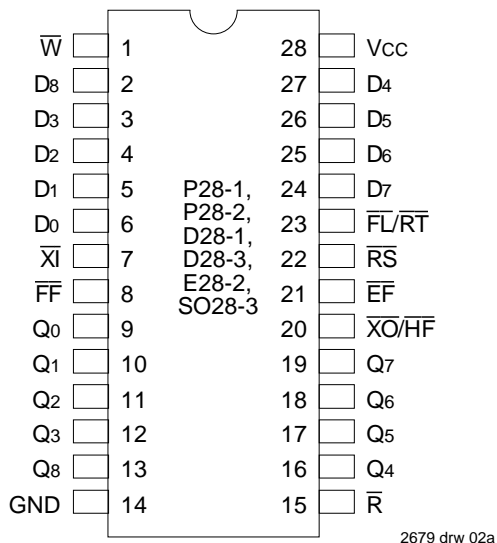

DIP/SOIC/CERPACK
TOP VIEW

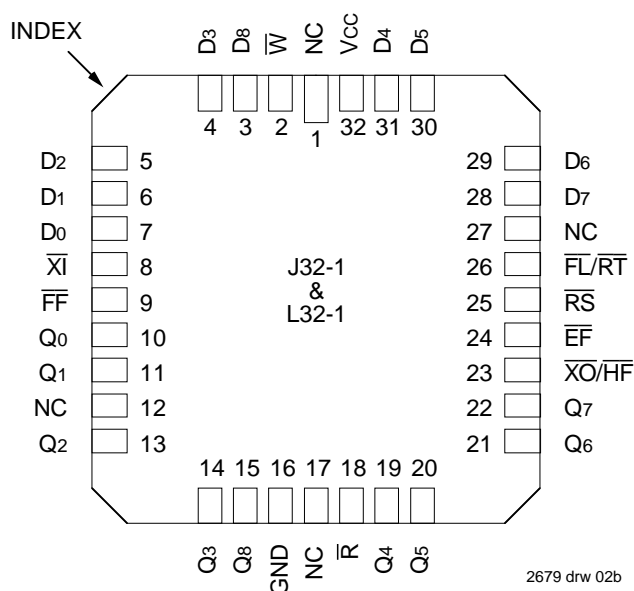

LCC/PLCC
TOP VIEW

NOTE:

- CERPACK (E28-2) and 600-mil-wide DIP (P28-1 and D28-1) not available for 7200.

NOTE:

- LCC (L32-1) not available for 7200.

ABSOLUTE MAXIMUM RATINGS⁽¹⁾

Symbol	Rating	Com'l.	Mil.	Unit
VTERM	Terminal Voltage with Respect to GND	-0.5 to +7.0	-0.5 to +7.0	V
TA	Operating Temperature	0 to +70	-55 to +125	°C
TBIAS	Temperature Under Bias	-55 to +125	-65 to +135	°C
TSTG	Storage Temperature	-55 to +125	-65 to +155	°C
IOUT	DC Output Current	50	50	mA

NOTE:

- Stresses greater than those listed under ABSOLUTE MAXIMUM RATINGS may cause permanent damage to the device. This is a stress rating only and functional operation of the device at these or any other conditions above those indicated in the operational sections of this specification is not implied. Exposure to absolute maximum rating conditions for extended periods may affect reliability.

2679 tbl 01

RECOMMENDED DC OPERATING CONDITIONS

Symbol	Parameter	Min.	Typ.	Max.	Unit
VCCM	Military Supply Voltage	4.5	5.0	5.5	V
VCC	Commercial Supply Voltage	4.5	5.0	5.5	V
GND	Supply Voltage	0	0	0	V
V _{IH} ⁽¹⁾	Input High Voltage Commercial	2.0	—	—	V
V _{IH} ⁽¹⁾	Input High Voltage Military	2.2	—	—	V
V _{IL} ⁽²⁾	Input Low Voltage Commercial and Military	—	—	0.8	V

NOTE:

- V_{IH} = 2.6V for X-bar input (commercial).
V_{IH} = 2.8V for X-bar input (military).
- 1.5V undershoots are allowed for 10ns once per cycle.

2679 tbl 03

CAPACITANCE (TA = +25°C, f = 1.0 MHz)

Symbol	Parameter ⁽¹⁾	Condition	Max.	Unit
CIN	Input Capacitance	V _{IN} = 0V	8	pF
COU	Output Capacitance	V _{OUT} = 0V	8	pF

NOTE:

- This parameter is sampled and not 100% tested.

2679 tbl 02

DC ELECTRICAL CHARACTERISTICS

(Commercial: $V_{CC} = 5.0V \pm 10\%$, $T_A = 0^\circ C$ to $+70^\circ C$; Military: $V_{CC} = 5.0V \pm 10\%$, $T_A = -55^\circ C$ to $+125^\circ C$)

Symbol	Parameter	IDT7200L IDT7201LA IDT7202LA Commercial $t_A = 12, 15, 20$ ns			IDT7200L IDT7201LA IDT7202LA Military $t_A = 20$ ns			IDT7200L IDT7201LA IDT7202LA Commercial $t_A = 25, 35$ ns			Unit
		Min.	Typ.	Max.	Min.	Typ.	Max.	Min.	Typ.	Max.	
$I_{LI}^{(1)}$	Input Leakage Current (Any Input)	-1	—	1	-10	—	10	-1	—	1	μA
$I_{LO}^{(2)}$	Output Leakage Current	-10	—	10	-10	—	10	-10	—	10	μA
V_{OH}	Output Logic "1" Voltage $I_{OH} = -2mA$	2.4	—	—	2.4	—	—	2.4	—	—	V
V_{OL}	Output Logic "0" Voltage $I_{OL} = 8mA$	—	—	0.4	—	—	0.4	—	—	0.4	V
$I_{CC1}^{(3)}$	Active Power Supply Current	—	—	125 ⁽⁴⁾	—	—	140 ⁽⁴⁾	—	—	125 ⁽⁴⁾	mA
$I_{CC2}^{(3)}$	Standby Current ($R=W=RS=FL/RT=V_{IH}$)	—	—	15	—	—	20	—	—	15	mA
$I_{CC3(L)}^{(3)}$	Power Down Current (All Input = $V_{CC} - 0.2V$)	—	—	0.5	—	—	0.9	—	—	0.5	mA

NOTES:

1. Measurements with $0.4 \leq V_{IN} \leq V_{CC}$.
2. $\bar{R} \geq V_{IH}$, $0.4 \leq V_{OUT} \leq V_{CC}$.
3. I_{CC} measurements are made with outputs open (only capacitive loading).
4. Tested at $f = 20MHz$.

2679 tbl 05

DC ELECTRICAL CHARACTERISTICS (Continued)

(Commercial: $V_{CC} = 5.0V \pm 10\%$, $T_A = 0^\circ C$ to $+70^\circ C$; Military: $V_{CC} = 5.0V \pm 10\%$, $T_A = -55^\circ C$ to $+125^\circ C$)

Symbol	Parameter	IDT7200L IDT7201LA IDT7202LA Military $t_A = 30, 40$ ns			IDT7200L IDT7201LA IDT7202LA Commercial $t_A = 50$ ns			IDT7200L IDT7201LA IDT7202LA Military $t_A = 50, 65, 80, 120$ ns			Unit
		Min.	Typ.	Max.	Min.	Typ.	Max.	Min.	Typ.	Max.	
$I_{LI}^{(1)}$	Input Leakage Current (Any Input)	-10	—	10	-1	—	1	-10	—	10	μA
$I_{LO}^{(2)}$	Output Leakage Current	-10	—	10	-10	—	10	-10	—	10	μA
V_{OH}	Output Logic "1" Voltage $I_{OH} = -2mA$	2.4	—	—	2.4	—	—	2.4	—	—	V
V_{OL}	Output Logic "0" Voltage $I_{OL} = 8mA$	—	—	0.4	—	—	0.4	—	—	0.4	V
$I_{CC1}^{(3)}$	Active Power Supply Current	—	—	140 ⁽⁴⁾	—	50	80	—	70	100	mA
$I_{CC2}^{(3)}$	Standby Current ($R=W=RS=FL/RT=V_{IH}$)	—	—	20	—	5	8	—	8	15	mA
$I_{CC3(L)}^{(3)}$	Power Down Current (All Input = $V_{CC} - 0.2V$)	—	—	0.9	—	—	0.5	—	—	0.9	mA

NOTES:

1. Measurements with $0.4 \leq V_{IN} \leq V_{CC}$.
2. $\bar{R} \geq V_{IH}$, $0.4 \leq V_{OUT} \leq V_{CC}$.
3. I_{CC} measurements are made with outputs open (only capacitive loading).
4. Tested at $f = 20MHz$.

2679 tbl 05

AC ELECTRICAL CHARACTERISTICS⁽¹⁾

(Commercial: VCC = 5.0V±10%, TA = 0°C to +70°C; Military: VCC = 5.0V±10%, TA = -55°C to +125°C)

Symbol	Parameter	Commercial		Com'l & Mil.		Com'l		Military		Com'l		Unit		
		7200L12 7201LA12 7202LA12		7200L15 7201LA15 7202LA15		7200L20 7201LA20 7202LA20		7200L25 7201LA25 7202LA25		7200L30 7201LA30 7202LA30			7200L35 7201LA35 7202LA35	
		Min.	Max.	Min.	Max.	Min.	Max.	Min.	Max.	Min.	Max.		Min.	Max.
ts	Shift Frequency	—	50	—	40	—	33.3	—	28.5	—	25	—	22.2	MHz
tRC	Read Cycle Time	20	—	25	—	30	—	35	—	40	—	45	—	ns
tA	Access Time	—	12	—	15	—	20	—	25	—	30	—	35	ns
tRR	Read Recovery Time	8	—	10	—	10	—	10	—	10	—	10	—	ns
tRPW	Read Pulse Width ⁽²⁾	12	—	15	—	20	—	25	—	30	—	35	—	ns
tRLZ	Read Pulse Low to Data Bus at Low Z ⁽³⁾	3	—	5	—	5	—	5	—	5	—	5	—	ns
tWLZ	Write Pulse High to Data Bus at Low Z ^(3, 4)	3	—	5	—	5	—	5	—	5	—	10	—	ns
tDV	Data Valid from Read Pulse High	5	—	5	—	5	—	5	—	5	—	5	—	ns
tRHZ	Read Pulse High to Data Bus at High Z ⁽³⁾	—	12	—	15	—	15	—	18	—	20	—	20	ns
tWC	Write Cycle Time	20	—	25	—	30	—	35	—	40	—	45	—	ns
tWPW	Write Pulse Width ⁽²⁾	12	—	15	—	20	—	25	—	30	—	35	—	ns
tWR	Write Recovery Time	8	—	10	—	10	—	10	—	10	—	10	—	ns
tDS	Data Set-up Time	9	—	11	—	12	—	15	—	18	—	18	—	ns
tDH	Data Hold Time	0	—	0	—	0	—	0	—	0	—	0	—	ns
tRSC	Reset Cycle Time	20	—	25	—	30	—	35	—	40	—	45	—	ns
tRS	Reset Pulse Width ⁽²⁾	12	—	15	—	20	—	25	—	30	—	35	—	ns
tRSS	Reset Set-up Time ⁽³⁾	12	—	15	—	20	—	25	—	30	—	35	—	ns
tRSR	Reset Recovery Time	8	—	10	—	10	—	10	—	10	—	10	—	ns
tRTC	Retransmit Cycle Time	20	—	25	—	30	—	35	—	40	—	45	—	ns
tRT	Retransmit Pulse Width ⁽²⁾	12	—	15	—	20	—	25	—	30	—	35	—	ns
tRTS	Retransmit Set-up Time ⁽³⁾	12	—	15	—	20	—	25	—	30	—	35	—	ns
tRTR	Retransmit Recovery Time	8	—	10	—	10	—	10	—	10	—	10	—	ns
tEFL	Reset to Empty Flag Low	—	12	—	25	—	30	—	35	—	40	—	45	ns
tHFH,FFH	Reset to Half-Full and Full Flag High	—	17	—	25	—	30	—	35	—	40	—	45	ns
tRTF	Retransmit Low to Flags Valid	—	20	—	25	—	30	—	35	—	40	—	45	ns
tREF	Read Low to Empty Flag Low	—	12	—	15	—	20	—	25	—	30	—	30	ns
tRFF	Read High to Full Flag High	—	14	—	15	—	20	—	25	—	30	—	30	ns
tRPE	Read Pulse Width after \overline{EF} High	12	—	15	—	20	—	25	—	30	—	35	—	ns
tWEF	Write High to Empty Flag High	—	12	—	15	—	20	—	25	—	30	—	30	ns
tWFF	Write Low to Full Flag Low	—	14	—	15	—	20	—	25	—	30	—	30	ns
tWHF	Write Low to Half-Full Flag Low	—	17	—	25	—	30	—	35	—	40	—	45	ns
tRHF	Read High to Half-Full Flag High	—	17	—	25	—	30	—	35	—	40	—	45	ns
tWPF	Write Pulse Width after \overline{FF} High	12	—	15	—	20	—	25	—	30	—	35	—	ns
tXOL	Read/Write to \overline{XO} Low	—	12	—	15	—	20	—	25	—	30	—	35	ns
tXOH	Read/Write to \overline{XO} High	—	12	—	15	—	20	—	25	—	30	—	35	ns
tXI	\overline{XI} Pulse Width ⁽²⁾	12	—	15	—	20	—	25	—	30	—	35	—	ns
tXIR	\overline{XI} Recovery Time	8	—	10	—	10	—	10	—	10	—	10	—	ns
tXIS	\overline{XI} Set-up Time	8	—	10	—	10	—	10	—	10	—	10	—	ns

NOTES:

1. Timings referenced as in AC Test Conditions.
2. Pulse widths less than minimum value are not allowed.
3. Values guaranteed by design, not currently tested.
4. Only applies to read data flow-through mode.

2679 tbl 06

AC ELECTRICAL CHARACTERISTICS⁽¹⁾ (Continued)

(Commercial: V_{CC} = 5.0V±10%, T_A = 0°C to +70°C; Military: V_{CC} = 5.0V±10%, T_A = -55°C to +125°C)

Symbol	Parameter	Military		Com'I & Mil.		Military ⁽²⁾						Unit
		7200 L40 7201LA40 7202LA40		7200L50 7201LA50 7202LA50		7200L65 7201LA65 7202LA65		7200L80 7201LA80 7202LA80		7200L120 7201LA120 7202LA120		
		Min.	Max.	Min.	Max.	Min.	Max.	Min.	Max.	Min.	Max.	
ts	Shift Frequency	—	20	—	15	—	12.5	—	10	—	7	MHz
trc	Read Cycle Time	50	—	65	—	80	—	100	—	140	—	ns
ta	Access Time	—	40	—	50	—	65	—	80	—	120	ns
trr	Read Recovery Time	10	—	15	—	15	—	20	—	20	—	ns
trpw	Read Pulse Width ⁽³⁾	40	—	50	—	65	—	80	—	120	—	ns
trlz	Read Pulse Low to Data Bus at Low Z ⁽⁴⁾	5	—	10	—	10	—	10	—	10	—	ns
twlz	Write Pulse High to Data Bus at Low Z ^(4, 5)	10	—	15	—	15	—	20	—	20	—	ns
tdv	Data Valid from Read Pulse High	5	—	5	—	5	—	5	—	5	—	ns
trhz	Read Pulse High to Data Bus at High Z ⁽⁴⁾	—	25	—	30	—	30	—	30	—	35	ns
twc	Write Cycle Time	50	—	65	—	80	—	100	—	140	—	ns
twpw	Write Pulse Width ⁽³⁾	40	—	50	—	65	—	80	—	120	—	ns
twr	Write Recovery Time	10	—	15	—	15	—	20	—	20	—	ns
tds	Data Set-up Time	20	—	30	—	30	—	40	—	40	—	ns
tdh	Data Hold Time	0	—	5	—	10	—	10	—	10	—	ns
trsc	Reset Cycle Time	50	—	65	—	80	—	100	—	140	—	ns
trs	Reset Pulse Width ⁽³⁾	40	—	50	—	65	—	80	—	120	—	ns
trss	Reset Set-up Time ⁽⁴⁾	40	—	50	—	65	—	80	—	120	—	ns
trsr	Reset Recovery Time	10	—	15	—	15	—	20	—	20	—	ns
trtc	Retransmit Cycle Time	50	—	65	—	80	—	100	—	140	—	ns
trt	Retransmit Pulse Width ⁽³⁾	40	—	50	—	65	—	80	—	120	—	ns
trts	Retransmit Set-up Time ⁽⁴⁾	40	—	50	—	65	—	80	—	120	—	ns
trtr	Retransmit Recovery Time	10	—	15	—	15	—	20	—	20	—	ns
tefl	Reset to Empty Flag Low	—	50	—	65	—	80	—	100	—	140	ns
thfh,ffh	Reset to Half-Full and Full Flag High	—	50	—	65	—	80	—	100	—	140	ns
trtl	Retransmit Low to Flags Valid	—	50	—	65	—	80	—	100	—	140	ns
trfl	Read Low to Empty Flag Low	—	30	—	45	—	60	—	60	—	60	ns
trff	Read High to Full Flag High	—	35	—	45	—	60	—	60	—	60	ns
trpe	Read Pulse Width after \overline{EF} High	40	—	50	—	65	—	80	—	120	—	ns
tweh	Write High to Empty Flag High	—	35	—	45	—	60	—	60	—	60	ns
twfl	Write Low to Full Flag Low	—	35	—	45	—	60	—	60	—	60	ns
twhf	Write Low to Half-Full Flag Low	—	50	—	65	—	80	—	100	—	140	ns
trhf	Read High to Half-Full Flag High	—	50	—	65	—	80	—	100	—	140	ns
twpf	Write Pulse Width after \overline{FF} High	40	—	50	—	65	—	80	—	120	—	ns
txol	Read/Write to \overline{XO} Low	—	40	—	50	—	65	—	80	—	120	ns
txoh	Read/Write to \overline{XO} High	—	40	—	50	—	65	—	80	—	120	ns
txi	\overline{XI} Pulse Width ⁽³⁾	40	—	50	—	65	—	80	—	120	—	ns
txir	\overline{XI} Recovery Time	10	—	10	—	10	—	10	—	10	—	ns
txis	\overline{XI} Set-up Time	10	—	15	—	15	—	15	—	15	—	ns

NOTES:

1. Timings referenced as in AC Test Conditions
2. Speed grades 65, 80 and 120 not available in the CERPACK
3. Pulse widths less than minimum value are not allowed.

4. Values guaranteed by design, not currently tested.
5. Only applies to read data flow-through mode.

2679 tbl 07

AC TEST CONDITIONS

Input Pulse Levels	GND to 3.0V
Input Rise/Fall Times	5ns
Input Timing Reference Levels	1.5V
Output Reference Levels	1.5V
Output Load	See Figure 1

2679 tbl 08

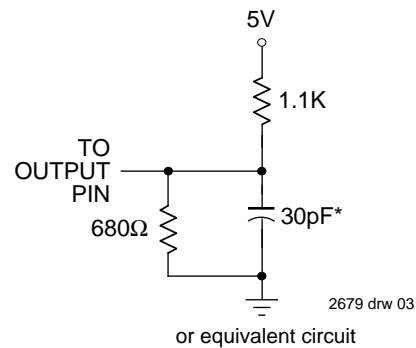

Figure 1. Output Load

* Includes scope and jig capacitances.

SIGNAL DESCRIPTIONS

INPUTS:

DATA IN (D₀ – D₈)

Data inputs for 9-bit wide data.

CONTROLS:

RESET (\overline{RS})

Reset is accomplished whenever the Reset (\overline{RS}) input is taken to a low state. During reset, both internal read and write pointers are set to the first location. A reset is required after power up before a write operation can take place. **Both the Read Enable (\overline{R}) and Write Enable (\overline{W}) inputs must be in the high state during the window shown in Figure 2, (i.e., t_{RSS} before the rising edge of \overline{RS}) and should not change until t_{RSR} after the rising edge of \overline{RS} . Half-Full Flag (\overline{HF}) will be reset to high after Reset (\overline{RS}).**

WRITE ENABLE (\overline{W})

A write cycle is initiated on the falling edge of this input if the Full Flag (\overline{FF}) is not set. Data set-up and hold times must be adhered to with respect to the rising edge of the Write Enable (\overline{W}). Data is stored in the RAM array sequentially and independently of any on-going read operation.

After half of the memory is filled and at the falling edge of the next write operation, the Half-Full Flag (\overline{HF}) will be set to low and will remain set until the difference between the write pointer and read pointer is less than or equal to one half of the total memory of the device. The Half-Full Flag (\overline{HF}) is then reset by the rising edge of the read operation.

To prevent data overflow, the Full Flag (\overline{FF}) will go low, inhibiting further write operations. Upon the completion of a valid read operation, the Full Flag (\overline{FF}) will go high after t_{RFF} , allowing a valid write to begin. When the FIFO is full, the internal write pointer is blocked from \overline{W} , so external changes in \overline{W} will not affect the FIFO when it is full.

READ ENABLE (\overline{R})

A read cycle is initiated on the falling edge of the Read Enable (\overline{R}) provided the Empty Flag (\overline{EF}) is not set. The data is accessed on a First-In/First-Out basis, independent of any ongoing write operations. After Read Enable (\overline{R}) goes high,

the Data Outputs (Q₀ – Q₈) will return to a high impedance condition until the next Read operation. When all data has been read from the FIFO, the Empty Flag (\overline{EF}) will go low, allowing the “final” read cycle but inhibiting further read operations with the data outputs remaining in a high impedance state. Once a valid write operation has been accomplished, the Empty Flag (\overline{EF}) will go high after t_{WEF} and a valid Read can then begin. When the FIFO is empty, the internal read pointer is blocked from \overline{R} so external changes in \overline{R} will not affect the FIFO when it is empty.

FIRST LOAD/RETRANSMIT ($\overline{FL/RT}$)

This is a dual-purpose input. In the Depth Expansion Mode, this pin is grounded to indicate that it is the first loaded (see Operating Modes). In the Single Device Mode, this pin acts as the retransmit input. The Single Device Mode is initiated by grounding the Expansion In (\overline{XI}).

The IDT7200/7201A/7202A can be made to retransmit data when the Retransmit Enable control (\overline{RT}) input is pulsed low. A retransmit operation will set the internal read pointer to the first location and will not affect the write pointer. Read Enable (\overline{R}) and Write Enable (\overline{W}) must be in the high state during retransmit. This feature is useful when less than 256/512/1024 writes are performed between resets. The retransmit feature is not compatible with the Depth Expansion Mode and will affect the Half-Full Flag (\overline{HF}), depending on the relative locations of the read and write pointers.

EXPANSION IN (\overline{XI})

This input is a dual-purpose pin. Expansion In (\overline{XI}) is grounded to indicate an operation in the single device mode. Expansion In (\overline{XI}) is connected to Expansion Out (\overline{XO}) of the previous device in the Depth Expansion or Daisy Chain Mode.

OUTPUTS:

FULL FLAG (\overline{FF})

The Full Flag (\overline{FF}) will go low, inhibiting further write operation, when the write pointer is one location less than the read pointer, indicating that the device is full. If the read pointer is not moved after Reset (\overline{RS}), the Full-Flag (\overline{FF}) will go low after 256 writes for IDT7200, 512 writes for the IDT7201A and 1024 writes for the IDT7202A.

EMPTY FLAG (\overline{EF})

The Empty Flag (\overline{EF}) will go low, inhibiting further read operations, when the read pointer is equal to the write pointer, indicating that the device is empty.

EXPANSION OUT/HALF-FULL FLAG ($\overline{XO}/\overline{HF}$)

This is a dual-purpose output. In the single device mode, when Expansion In (\overline{XI}) is grounded, this output acts as an indication of a half-full memory.

After half of the memory is filled and at the falling edge of the next write operation, the Half-Full Flag (\overline{HF}) will be set low and will remain set until the difference between the write

pointer and read pointer is less than or equal to one half of the total memory of the device. The Half-Full Flag (\overline{HF}) is then reset by using rising edge of the read operation.

In the Depth Expansion Mode, Expansion Out (\overline{XO}) of the previous device. This output acts as a signal to the next device in the Daisy Chain by providing a pulse to the next device when the previous device reaches the last location of memory.

DATA OUTPUTS ($Q_0 - Q_8$)

Data outputs for 9-bit wide data. This data is in a high impedance condition whenever Read (\overline{R}) is in a high state.

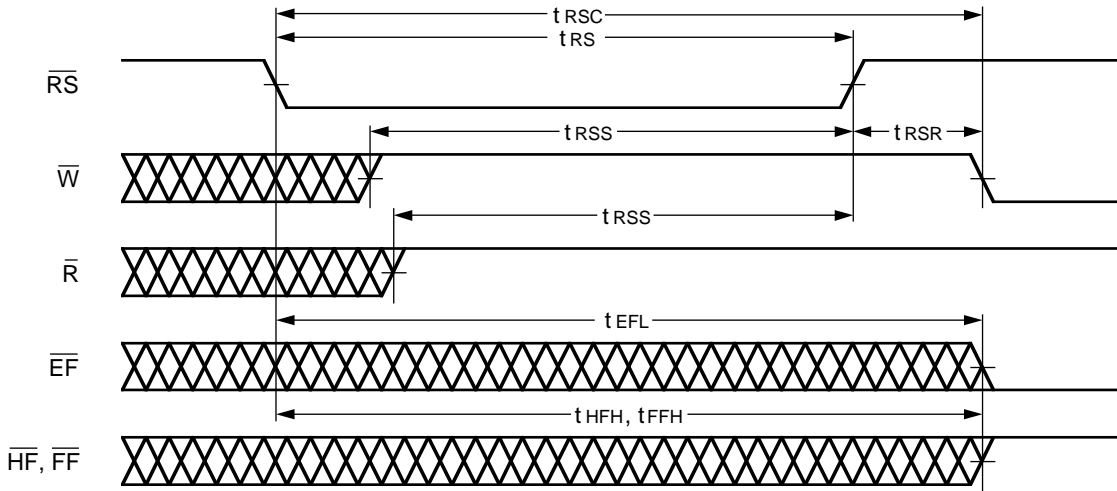

2679 drw 04

NOTES:

- $\overline{EF}, \overline{FF}, \overline{HF}$ may change status during Reset, but flags will be valid at t_{RSC} .
- \overline{W} and $\overline{R} = V_{IH}$ around the rising edge of \overline{RS} .

Figure 2. Reset

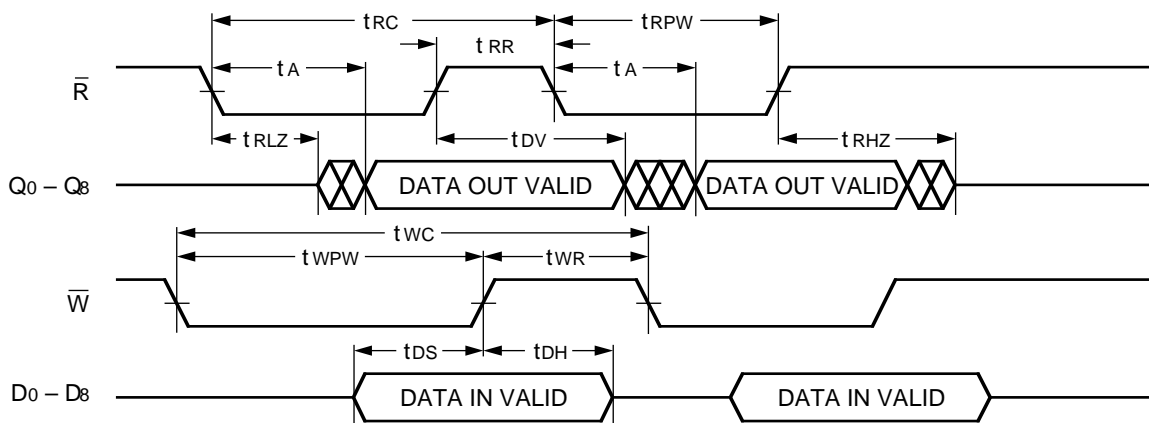

2679 drw 05

Figure 3. Asynchronous Write and Read Operation

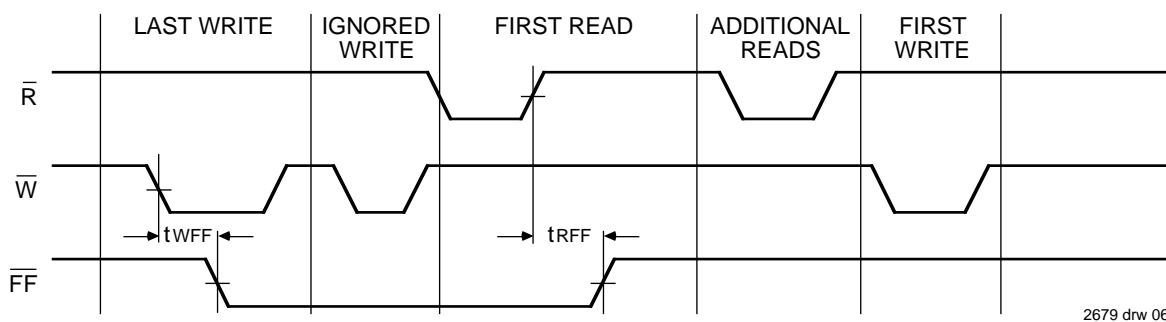

2679 drw 06

Figure 4. Full Flag From Last Write to First Read

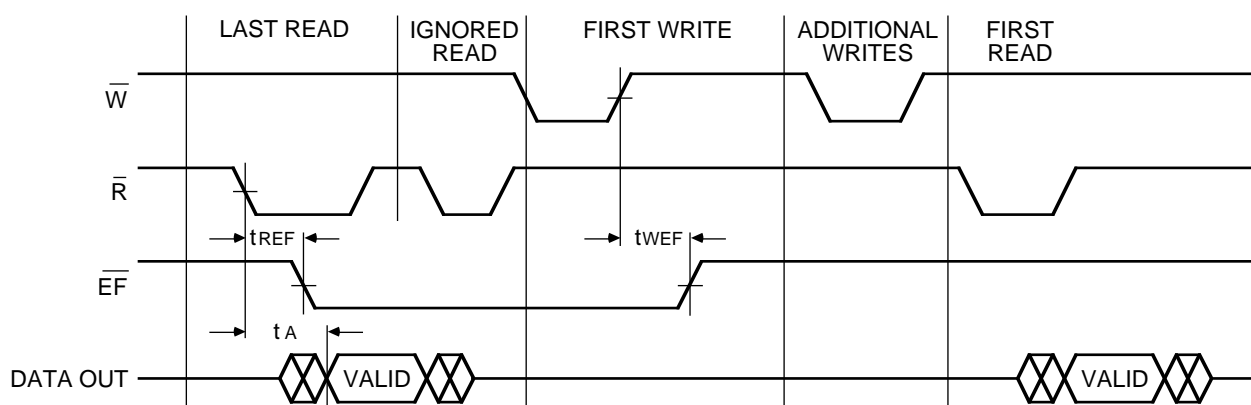

2679 drw 07

Figure 5. Empty Flag From Last Read to First Write

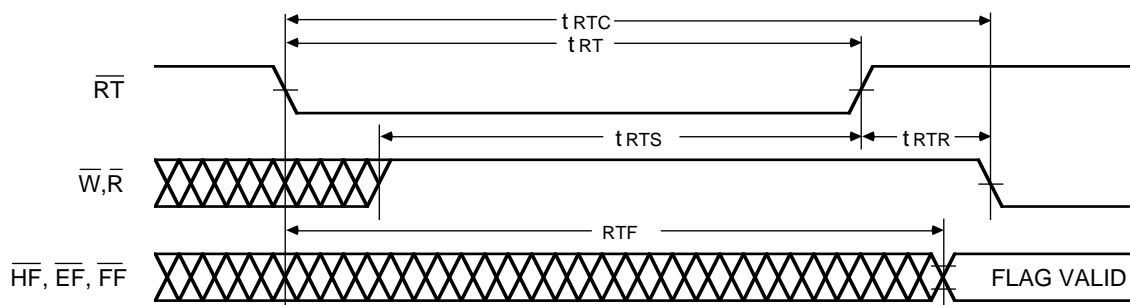

2679 drw 08

Figure 6. Retransmit

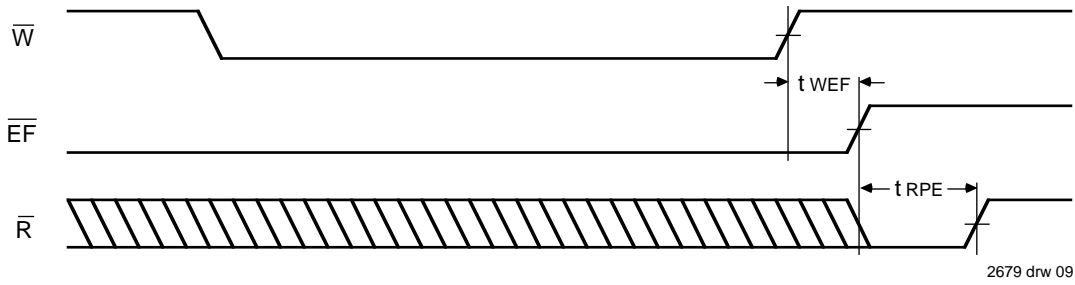

Figure 7. Minimum Timing for an Empty Flag Coincident Read Pulse

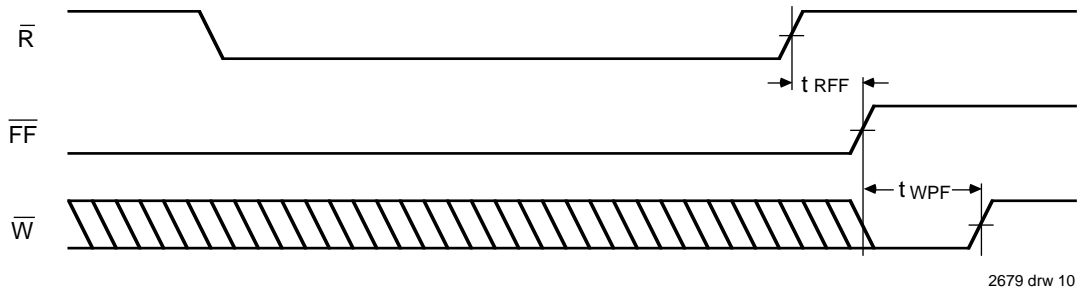

Figure 8. Minimum Timing for a Full Flag Coincident Write Pulse

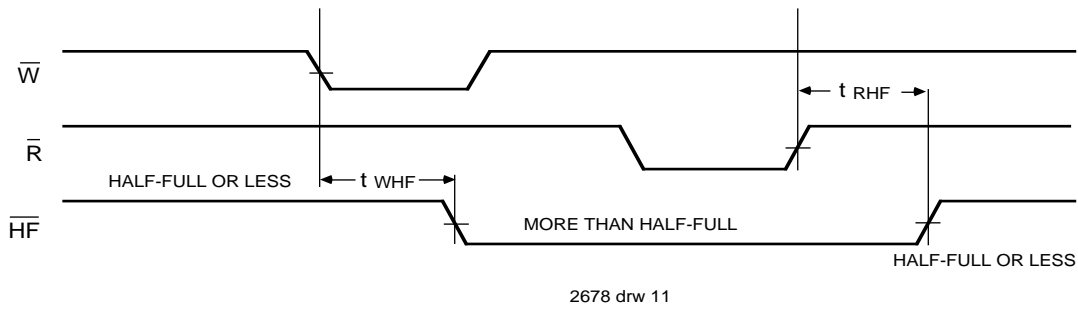

Figure 9. Half-Full Flag Timing

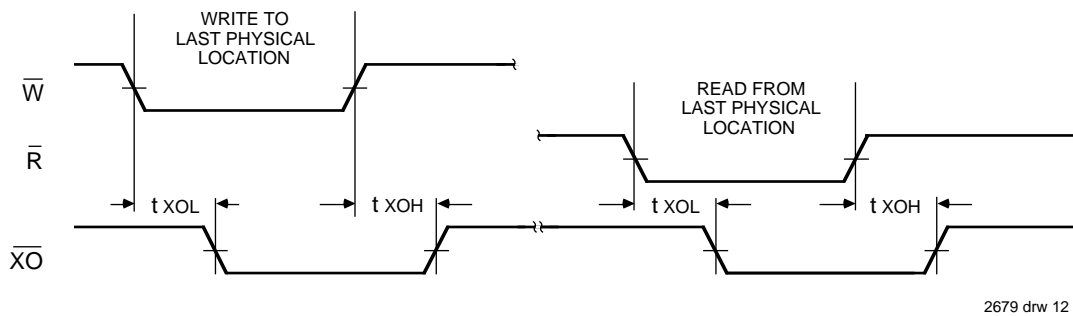

Figure 10. Expansion Out

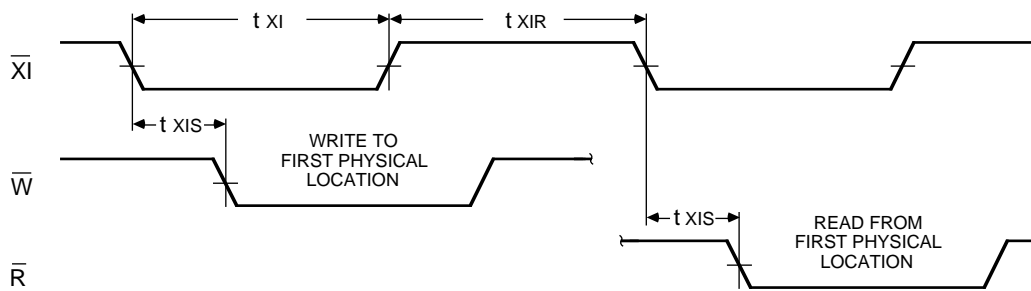

Figure 11. Expansion In

2679 drw 13

OPERATING MODES:

Care must be taken to assure that the appropriate flag is monitored by each system (i.e. \overline{FF} is monitored on the device where \overline{W} is used; \overline{EF} is monitored on the device where \overline{R} is used). For additional information, refer to Tech Note 8: *Operating FIFOs on Full and Empty Boundary Conditions* and Tech Note 6: *Designing with FIFOs*.

Single Device Mode

A single IDT7200/7201A/7202A may be used when the application requirements are for 256/512/1024 words or less. The IDT7200/7201A/7202A is in a Single Device Configuration when the Expansion In (\overline{XI}) control input is grounded (see Figure 12).

Depth Expansion

The IDT7200/7201A/7202A can easily be adapted to applications when the requirements are for greater than 256/512/1024 words. Figure 14 demonstrates Depth Expansion using three IDT7200/7201A/7202As. Any depth can be attained by adding additional IDT7200/7201A/7202As. The IDT7200/7201A/7202A operates in the Depth Expansion mode when the following conditions are met:

1. The first device must be designated by grounding the First Load (\overline{FL}) control input.
2. All other devices must have \overline{FL} in the high state.
3. The Expansion Out (\overline{XO}) pin of each device must be tied to the Expansion In (\overline{XI}) pin of the next device. See Figure 14.
4. External logic is needed to generate a composite Full Flag (\overline{FF}) and Empty Flag (\overline{EF}). This requires the ORing of all \overline{EF} s and ORing of all \overline{FF} s (i.e. all must be set to generate the correct composite \overline{FF} or \overline{EF}). See Figure 14.
5. The Retransmit (\overline{RT}) function and Half-Full Flag (\overline{HF}) are not available in the Depth Expansion Mode.

For additional information, refer to Tech Note 9: *Cascading FIFOs or FIFO Modules*.

USAGE MODES:

Width Expansion

Word width may be increased simply by connecting the corresponding input control signals of multiple devices. Status flags (\overline{EF} , \overline{FF} and \overline{HF}) can be detected from any one device. Figure 13 demonstrates an 18-bit word width by using two IDT7200/7201A/7202As. Any word width can be attained by adding additional IDT7200/7201A/7202As (Figure 13).

Bidirectional Operation

Applications which require data buffering between two systems (each system capable of Read and Write operations) can be achieved by pairing IDT7200/7201A/7202As as shown in Figure 16. Both Depth Expansion and Width Expansion may be used in this mode.

Data Flow-Through

Two types of flow-through modes are permitted, a read flow-through and write flow-through mode. For the read flow-through mode (Figure 17), the FIFO permits a reading of a single word after writing one word of data into an empty FIFO. The data is enabled on the bus in ($t_{WEF} + t_A$) ns after the rising edge of \overline{W} , called the first write edge, and it remains on the bus until the \overline{R} line is raised from low-to-high, after which the bus would go into a three-state mode after t_{RHZ} ns. The \overline{EF} line would have a pulse showing temporary deassertion and then would be asserted.

In the write flow-through mode (Figure 18), the FIFO permits the writing of a single word of data immediately after reading one word of data from a full FIFO. The \overline{R} line causes the \overline{FF} to be deasserted but the \overline{W} line being low causes it to be asserted again in anticipation of a new data word. On the rising edge of \overline{W} , the new word is loaded in the FIFO. The \overline{W} line must be toggled when \overline{FF} is not asserted to write new data in the FIFO and to increment the write pointer.

Compound Expansion

The two expansion techniques described above can be applied together in a straightforward manner to achieve large FIFO arrays (see Figure 15).

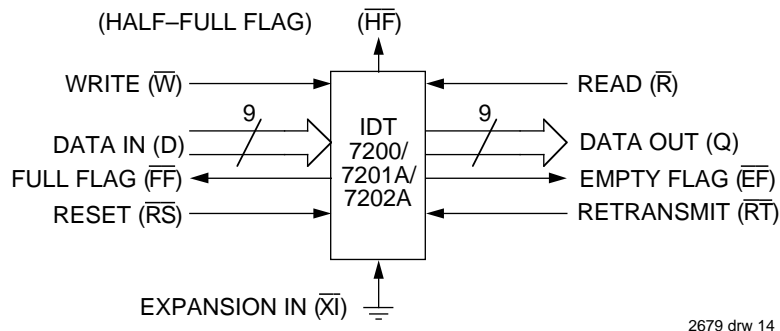

2679 drw 14

Figure 12. Block Diagram of Single 256/512/1024 x 9 FIFO

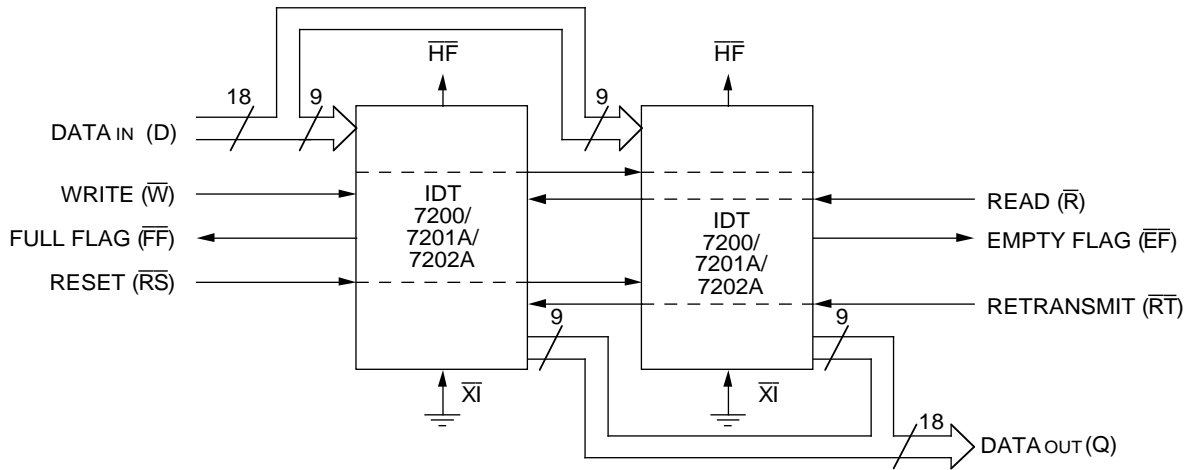

2679 drw 15

Figure 13. Block Diagram of 256/512/1024 x 18 FIFO Memory Used in Width Expansion Mode

TABLE I—RESET AND RETRANSMIT

Single Device Configuration/Width Expansion Mode

Mode	Inputs			Internal Status		Outputs		
	RS-bar	RT-bar	XI-bar	Read Pointer	Write Pointer	EF-bar	FF-bar	HF-bar
Reset	0	X	0	Location Zero	Location Zero	0	1	1
Retransmit	1	0	0	Location Zero	Unchanged	X	X	X
Read/Write	1	1	0	Increment ⁽¹⁾	Increment ⁽¹⁾	X	X	X

NOTE:

1. Pointer will increment if flag is High.

2679 tbl 09

TABLE II—RESET AND FIRST LOAD TRUTH TABLE

Depth Expansion/Compound Expansion Mode

Mode	Inputs			Internal Status		Outputs	
	RS-bar	FL-bar/RT-bar	XI-bar	Read Pointer	Write Pointer	EF-bar	FF-bar
Reset First Device	0	0	(1)	Location Zero	Location Zero	0	1
Reset All Other Devices	0	1	(1)	Location Zero	Location Zero	0	1
Read/Write	1	X	(1)	X	X	X	X

NOTE:

1. XI-bar is connected to XI-bar of previous device. See Figure 14. RS-bar = Reset Input, FL-bar/RT-bar = First Load/Retransmit, EF-bar = Empty Flag Output, FF-bar = Flag Full Output, XI-bar = Expansion Input, HF-bar = Half-Full Flag Output

2679 tbl 10

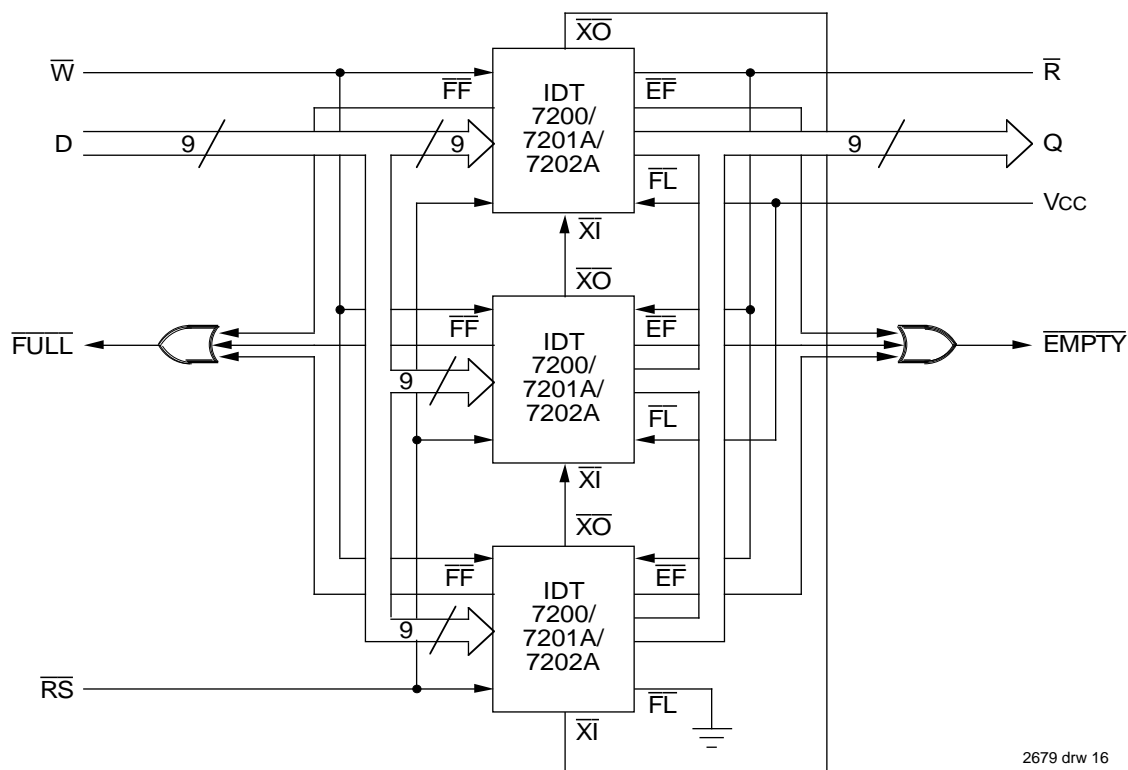

Figure 14. Block Diagram of 768 x 9/1536 x 9/3072 x 9 FIFO Memory (Depth Expansion)

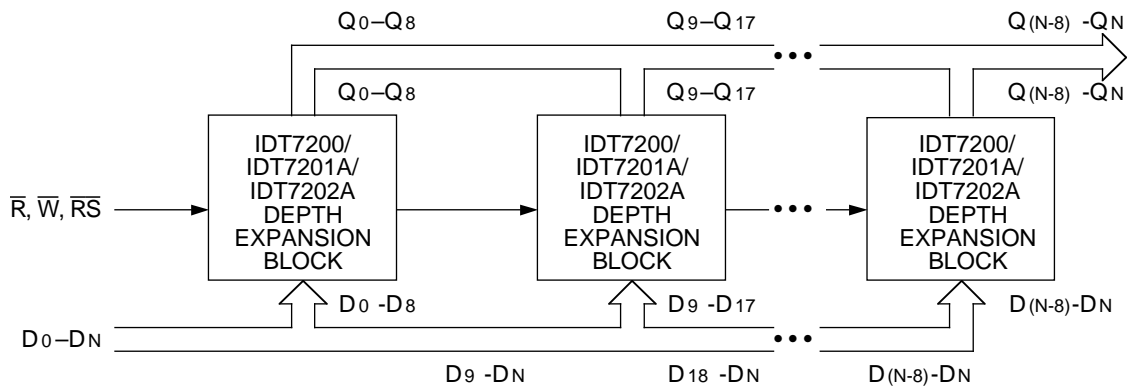
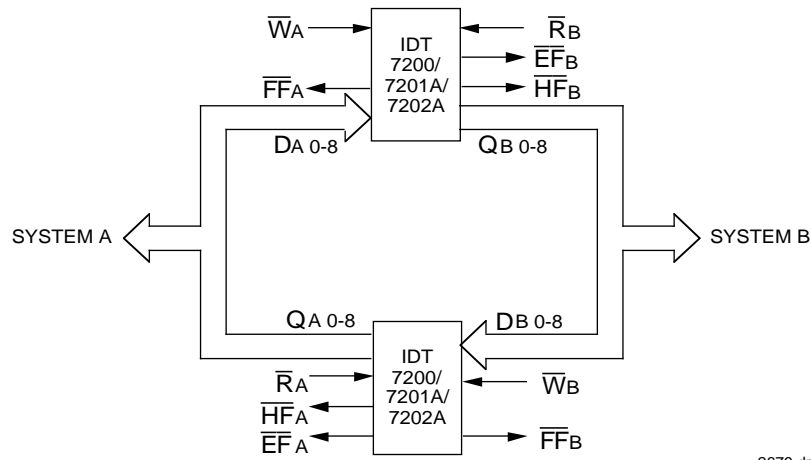

Figure 15. Compound FIFO Expansion

NOTES:

1. For depth expansion block see section on Depth Expansion and Figure 14.
2. For Flag detection see section on Width Expansion and Figure 13.



2679 drw 18

Figure 16. Bidirectional FIFO Mode

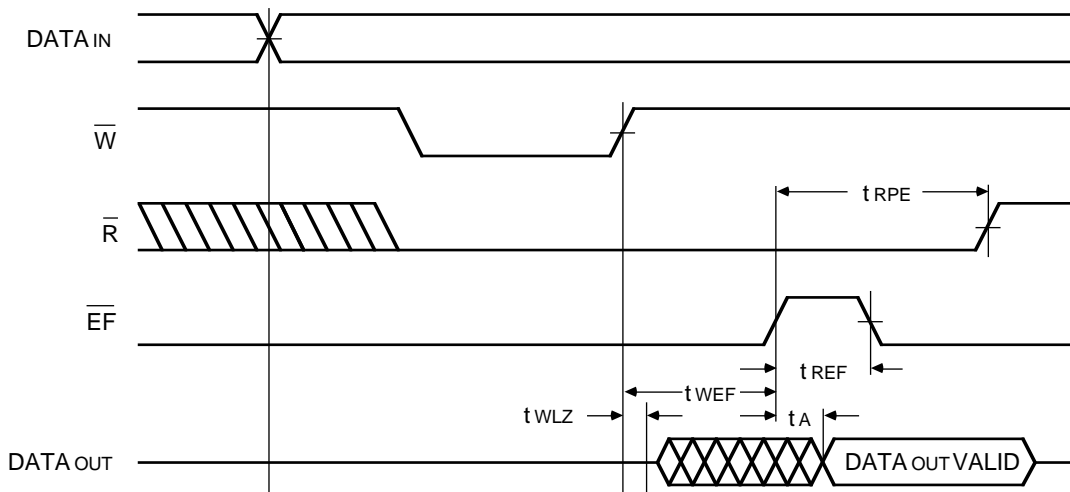

2679 drw 19

Figure 17. Read Data Flow-Through Mode

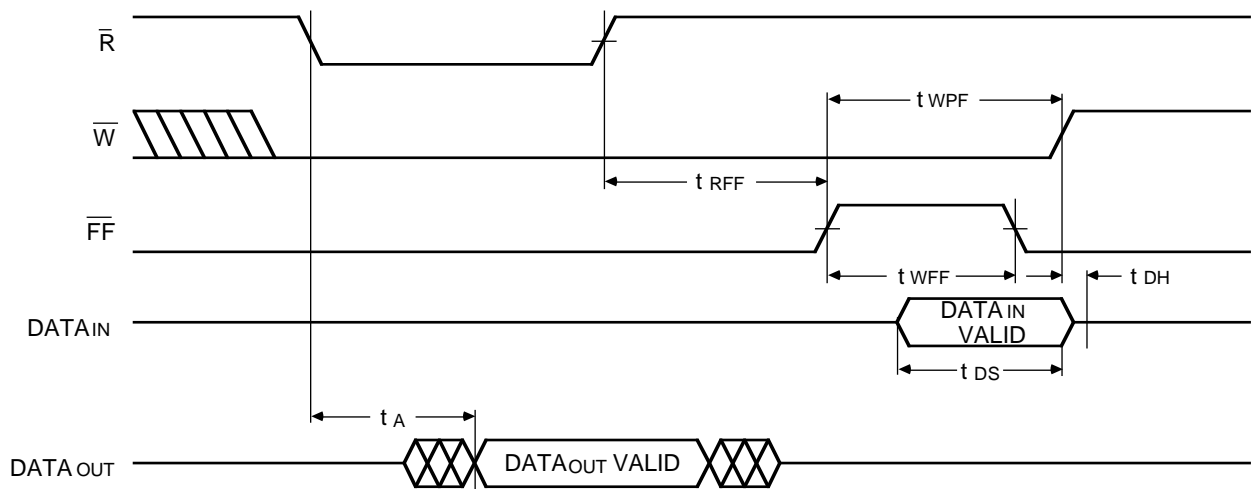

2679 drw 20

Figure 18. Write Data Flow-Through Mode

ORDERING INFORMATION

IDT	XXXX	X	XXX	X	X
	Device Type	Power	Speed	Package	Process/ Temperature Range

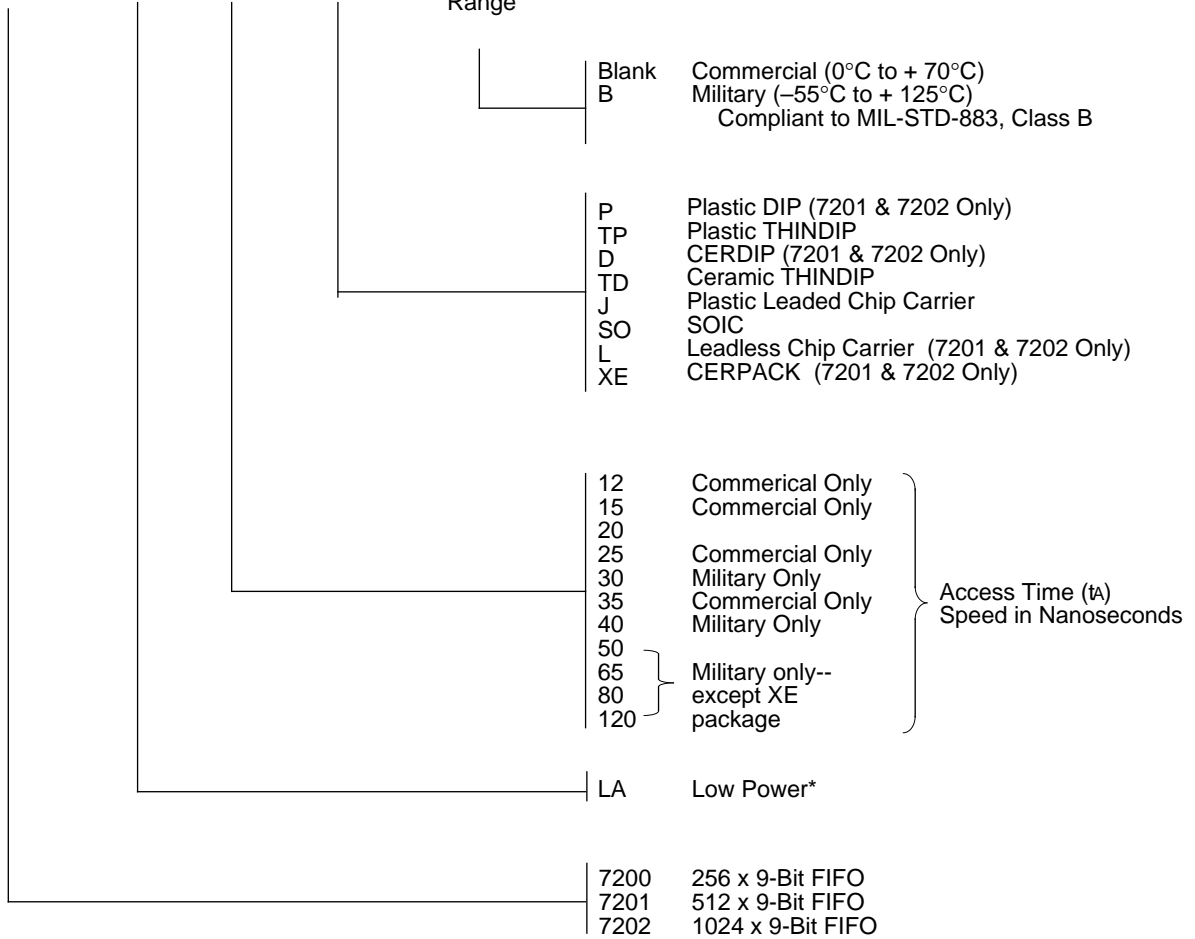

2679 drw 21

* "A" to be included for 7201 and 7202 ordering part number.

This datasheet has been downloaded from:

www.DatasheetCatalog.com

Datasheets for electronic components.



LittleDiode supplies new, hard to find or obsolete electronic components and semiconductors all over the world.

With over two million different components listed you are sure to find the part you need.

Feel free to visit us today at our online store:

LittleDiode.com

Looking forward to providing you with the best possible service.