

**CMOS Hex Voltage Level Shifter for TTL-to-CMOS or CMOS-to-CMOS Operation**

Intersil's Satellite Applications Flow™ (SAF) devices are fully tested and guaranteed to 100kRAD total dose. These QML Class T devices are processed to a standard flow intended to meet the cost and shorter lead-time needs of large volume satellite manufacturers, while maintaining a high level of reliability.

CD4504BT Hex Voltage Level Shifter consists of six circuits which shift input signals from the V<sub>CC</sub> logic level to the V<sub>DD</sub> logic level. To shift TTL signals to CMOS logic levels, the SELECT input is at the V<sub>CC</sub> HIGH logic state. When the SELECT input is at a LOW logic state, each circuit translates signals from one CMOS level to another.

**Specifications**

Specifications for Rad Hard QML devices are controlled by the Defense Supply Center in Columbus (DSCC). The SMD numbers listed below must be used when ordering.

Detailed Electrical Specifications for the CD4504BT are contained in SMD 5962-96665. A "hot-link" is provided from our website for downloading.

[www.intersil.com/spacedefense/newsafclasst.asp](http://www.intersil.com/spacedefense/newsafclasst.asp)

Intersil's Quality Management Plan (QM Plan), listing all Class T screening operations, is also available on our website.

[www.intersil.com/quality/manuals.asp](http://www.intersil.com/quality/manuals.asp)

**Ordering Information**

ORDERING NUMBER	PART NUMBER	TEMP. RANGE (°C)
5962R9666501TEC	CD4504BDTR	-55 to 125
5962R9666501TXC	CD4504BKTR	-55 to 125

NOTE: **Minimum order quantity for -T is 150 units through distribution, or 450 units direct.**

**Features**

- QML Class T, Per MIL-PRF-38535
- Radiation Performance
  - Gamma Dose (γ) 1 x 10<sup>5</sup> RAD(Si)
  - SEP Effective LET > 75 MEV/gm/cm<sup>2</sup>
- Independence of Power Supply Sequence Considerations
  - V<sub>CC</sub> Can Exceed V<sub>DD</sub>
  - Input Signals can Exceed Both V<sub>CC</sub> and V<sub>DD</sub>
- Up and Down Level Shifting Capability
- Shiftable Input Threshold for Either CMOS or TTL Compatibility
- 100% Tested for Quiescent Current at 20V
- 5V, 10V and 15V Parametric Ratings
- Standardized Symmetrical Output Characteristics

**Pinouts**

**CD4504BT (SBDIP), CDIP2-T16**  
TOP VIEW

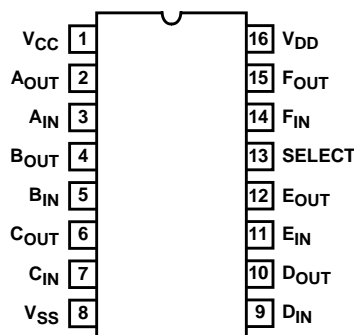

**CD4504BT (FLATPACK), CDIFP4-16**  
TOP VIEW

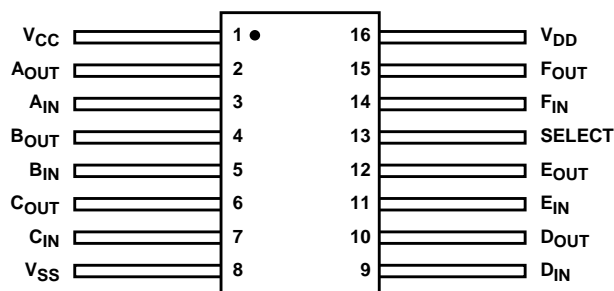

**Functional Diagram**

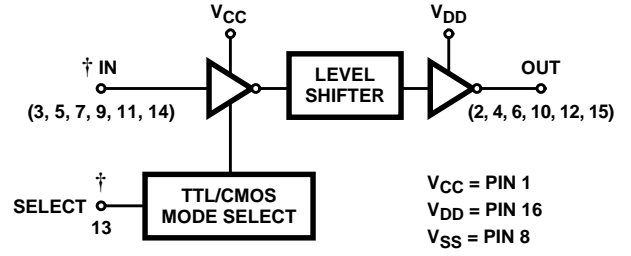
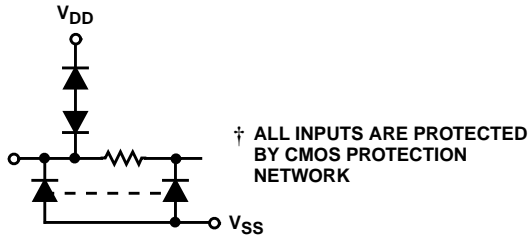

**Die Characteristics**

**DIE DIMENSIONS:**

(2540µm x 1753µm x 533µm ±25.4µm)  
100 x 69 x 21mils ±1mil

**METALLIZATION:**

Type: Al  
Thickness: 12.5kÅ ±1.5kÅ

**SUBSTRATE POTENTIAL:**

Leave Floating or Tie to V<sub>DD</sub>  
Bond Pad #16 (V<sub>DD</sub>) First

**BACKSIDE FINISH:**

Silicon

**PASSIVATION:**

Type: Phosphorus Doped Silox (SiO<sub>2</sub>)  
Thickness: 13.0kÅ ±2.6kÅ

**WORST CASE CURRENT DENSITY:**

< 2.0e5 A/cm<sup>2</sup>

**TRANSISTOR COUNT:**

72

**PROCESS:**

Bulk CMOS

**Metallization Mask Layout**

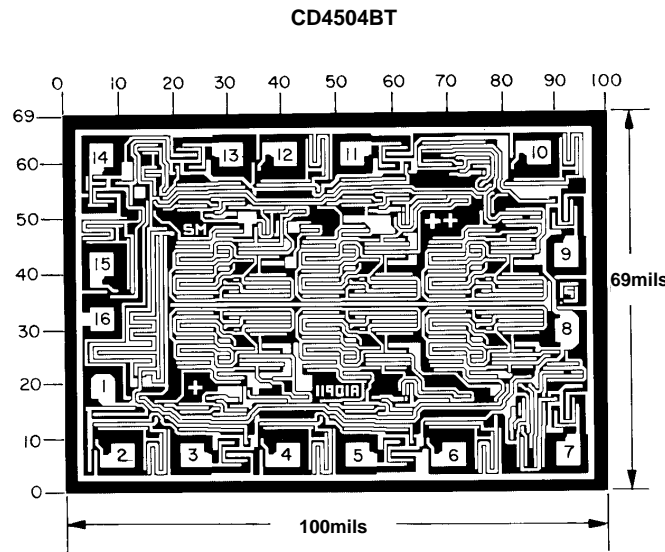

All Intersil semiconductor products are manufactured, assembled and tested under **ISO9000** quality systems certification.

*Intersil semiconductor products are sold by description only. Intersil Corporation reserves the right to make changes in circuit design and/or specifications at any time without notice. Accordingly, the reader is cautioned to verify that data sheets are current before placing orders. Information furnished by Intersil is believed to be accurate and reliable. However, no responsibility is assumed by Intersil or its subsidiaries for its use; nor for any infringements of patents or other rights of third parties which may result from its use. No license is granted by implication or otherwise under any patent or patent rights of Intersil or its subsidiaries.*

For information regarding Intersil Corporation and its products, see web site <http://www.intersil.com>

**Sales Office Headquarters**

**NORTH AMERICA**

Intersil Corporation  
P. O. Box 883, Mail Stop 53-204  
Melbourne, FL 32902  
TEL: (407) 724-7000  
FAX: (407) 724-7240

**EUROPE**

Intersil SA  
Mercure Center  
100, Rue de la Fusee  
1130 Brussels, Belgium  
TEL: (32) 2.724.2111  
FAX: (32) 2.724.22.05

**ASIA**

Intersil (Taiwan) Ltd.  
7F-6, No. 101 Fu Hsing North Road  
Taipei, Taiwan  
Republic of China  
TEL: (886) 2 2716 9310  
FAX: (886) 2 2715 3029

This datasheet has been downloaded from:

[www.DatasheetCatalog.com](http://www.DatasheetCatalog.com)

Datasheets for electronic components.



LittleDiode supplies new, hard to find or obsolete electronic components and semiconductors all over the world.

With over two million different components listed you are sure to find the part you need.

Feel free to visit us today at our online store:

[LittleDiode.com](http://LittleDiode.com)

Looking forward to providing you with the best possible service.