



Integrated Device Technology, Inc.

CMOS ASYNCHRONOUS FIFO WITH RETRANSMIT

1K x 9, 2K x 9, 4K x 9

IDT72021
IDT72031
IDT72041

FEATURES:

- First-In/First-Out Dual-Port memory
- Bit organization
 - IDT72021—1K x 9
 - IDT72031—2K x 9
 - IDT72041—4K x 9
- Ultra high speed
 - IDT72021—25ns access time
 - IDT72031—35ns access time
 - IDT72041—35ns access time
- Easily expandable in word depth and/or width
- Asynchronous and simultaneous read and write
- Functionally equivalent to IDT7202/03/04 with Output Enable (\overline{OE}) and Almost Empty/Almost Full Flag (\overline{AEF})
- Four status flags: Full, Empty, Half-Full (single device mode), and Almost Empty/Almost Full (7/8 empty or 7/8 full in single device mode)
- Output Enable controls the data output port
- Auto-retransmit capability
- Available in 32-pin DIP and PLCC
- Military product compliant to MIL-STD-883, Class B
- Industrial temperature range (-40°C to +85°C) is available, tested to military electrical specifications

DESCRIPTION:

IDT72021/031/041s are high-speed, low-power, dual-port memory devices commonly known as FIFOs (First-In/First-Out). Data can be written into and read from the memory at independent rates. The order of information stored and extracted does not change, but the rate of data entering the FIFO might be different than the rate leaving the FIFO. Unlike a Static RAM, no address information is required because the read and write pointers advance sequentially. The IDT72021/031/041s can perform asynchronous and simultaneous read and write operations. There are four status flags, (\overline{HF} , \overline{FF} , \overline{EF} , \overline{AEF}) to monitor data overflow and underflow. Output Enable (\overline{OE}) is provided to control the flow of data through the output port. Additional key features are Write (\overline{W}), Read (\overline{R}), Retransmit (\overline{RT}), First Load (\overline{FL}), Expansion In (\overline{XI}) and Expansion Out (\overline{XO}). The IDT72021/031/041s are designed for those applications requiring data control flags and Output Enable (\overline{OE}) in multiprocessing and rate buffer applications.

The IDT72021/031/041s are fabricated using IDT's CMOS technology. Military grade product is manufactured in compliance with the latest version of MIL-STD-883, Class B, for high reliability systems.

FUNCTIONAL BLOCK DIAGRAM

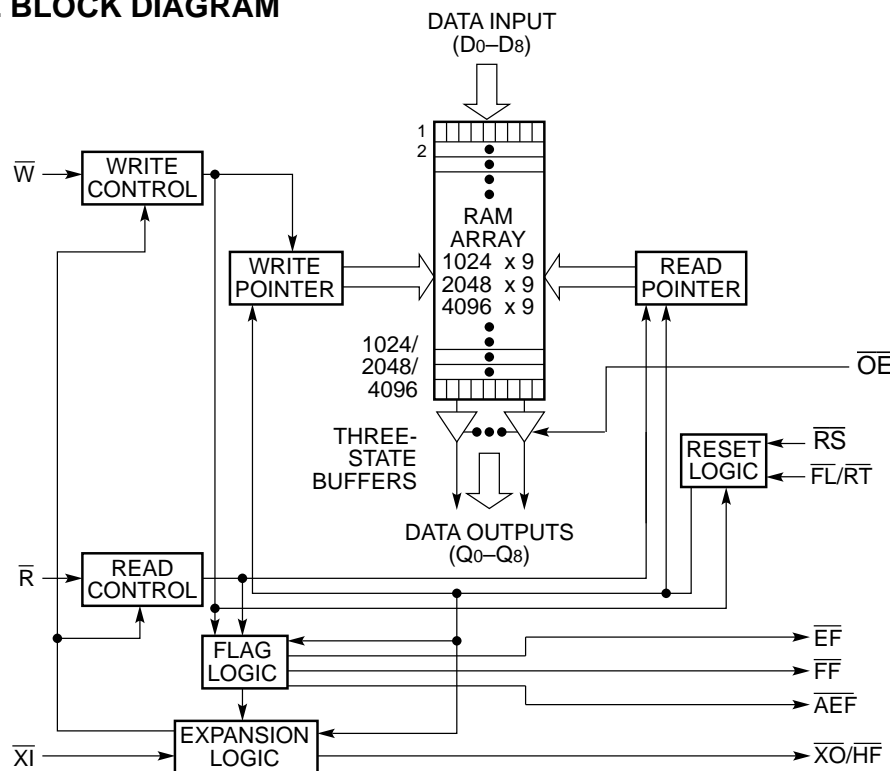

2677 drw 01

The IDT logo is a registered trademark of Integrated Device Technology, Inc. FAST is a trademark of National Semiconductor Co.

MILITARY AND COMMERCIAL TEMPERATURE RANGES

DECEMBER 1996

PIN CONFIGURATIONS

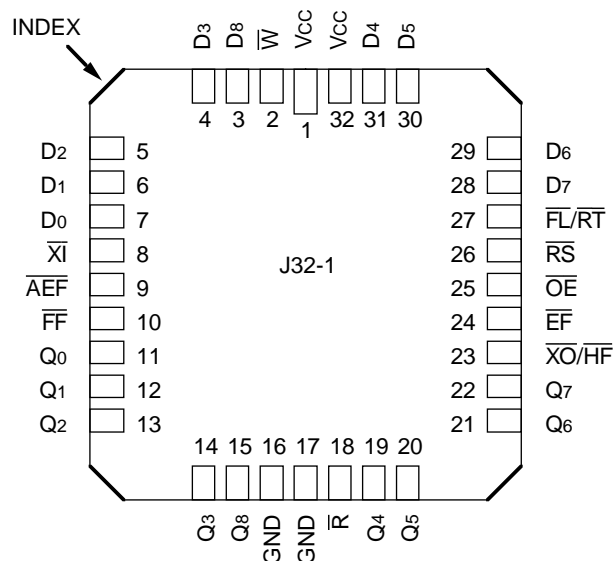

2677 drw 03

PLCC TOP VIEW

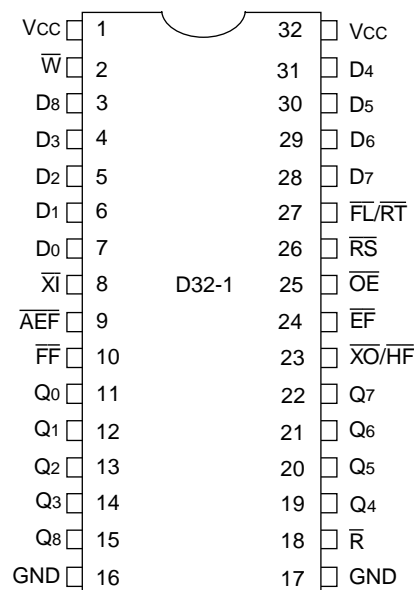

2677 drw 02

DIP TOP VIEW

PIN DESCRIPTIONS

Symbol	Name	I/O	Description
D ₀ –D ₈	Inputs	I	Data inputs for 9-bit wide data.
\overline{RS}	Reset	I	When \overline{RS} is set LOW, internal READ and WRITE pointers are set to the first location of the RAM array. HF and FF go HIGH, and AEF and EF go LOW. A reset is required before an initial WRITE after power-up. R and \overline{W} must be HIGH during \overline{RS} cycle.
\overline{W}	Write	I	When WRITE is LOW, data can be written into the RAM array sequentially, independent of READ. In order for WRITE to be active, \overline{FF} must be HIGH. When the FIFO is full (\overline{FF} -LOW), the internal WRITE operation is blocked.
\overline{R}	Read	I	When READ is LOW, data can be read from the RAM array sequentially, independent of WRITE. In order for READ to be active, \overline{EF} must be HIGH. When the FIFO is empty (\overline{EF} -LOW), the internal READ operation is blocked. The three-state output buffer is controlled by the read signal and the external output control (\overline{OE}).
$\overline{FL/RT}$	First Load/ Retransmit	I	This is a dual-purpose input. In the single device configuration (\overline{XI} grounded), activating retransmit ($\overline{FL/RT}$ -LOW) will set the internal READ pointer to the first location. There is no effect on the WRITE pointer. R and \overline{W} must be HIGH before setting $\overline{FL/RT}$ LOW. Retransmit is not compatible with depth expansion. In the depth expansion configuration, $\overline{FL/RT}$ -LOW indicates the first activated device.
\overline{XI}	Expansion In	I	In the single device configuration, \overline{XI} is grounded. In depth expansion or daisy chain expansion, \overline{XI} is connected to \overline{XO} (expansion out) of the previous device.
\overline{OE}	Output Enable	I	When \overline{OE} is set HIGH, the data flow through the three-state output buffer is inhibited regardless of an active READ operation. A read operation does increment the read pointer in this situation. When \overline{OE} is set LOW, Q ₀ -Q ₈ are still in a HIGH impedance condition if no READ occurs. For a complete READ operation with data appearing on Q ₀ -Q ₈ , both \overline{R} and \overline{OE} should be asserted LOW.
\overline{FF}	Full Flag	O	When \overline{FF} goes LOW, the device is full and further WRITE operations are inhibited. When \overline{FF} is HIGH, the device is not full.
\overline{EF}	Empty Flag	O	When \overline{EF} goes LOW, the device is empty and further READ operations are inhibited. When \overline{EF} is HIGH, the device is not empty.
\overline{AEF}	Almost-Empty/ Almost-Full Flag	O	When \overline{AEF} is LOW, the device is empty to 1/8 full or 7/8 to completely full. When \overline{AEF} is HIGH, the device is greater than 1/8 full, but less than 7/8 full.
$\overline{XO/HF}$	Expansion Out/ Half-Full Flag	O	This is a dual purpose output. In the single device configuration (\overline{XI} grounded), the device is more than half full when \overline{HF} is LOW. In the depth expansion configuration (\overline{XO} connected to \overline{XI} of the next device), a pulse is sent from \overline{XO} to \overline{XI} when the last location in the RAM array is filled.
Q ₀ –Q ₈	Outputs	O	Data outputs for 9-bit wide data.

2677 tbl 01

STATUS FLAG

Number of Words in FIFO			\overline{FF}	\overline{AEF}	\overline{HF}	\overline{EF}
1K	2K	4K				
0	0	0	H	L	H	L
1-127	1-255	1-511	H	L	H	H
128-512	256-1024	512-2048	H	H	H	H
513-896	1025-1792	2049-3584	H	H	L	H
897-1023	1793-2047	3585-4095	H	L	L	H
1024	2048	4096	L	L	L	H

2677 tbl 02

ABSOLUTE MAXIMUM RATINGS⁽¹⁾

Symbol	Rating	Com'l.	Mil.	Unit
VTERM	Terminal Voltage with Respect to GND	-0.5 to +7.0	-0.5 to +7.0	V
TA	Operating Temperature	0 to +70	-55 to +125	°C
TBIAS	Temperature Under Bias	-55 to +125	-65 to +135	°C
TSTG	Storage Temperature	-55 to +125	-65 to +155	°C
IOUT	DC Output Current	50	50	mA

NOTE:

2677 tbl 04

- Stresses greater than those listed under ABSOLUTE MAXIMUM RATINGS may cause permanent damage to the device. This is a stress rating only and functional operation of the device at these or any other conditions above those indicated in the operational sections of this specification is not implied. Exposure to absolute maximum rating conditions for extended periods may affect reliability.

CAPACITANCE ($T_A = +25^\circ\text{C}$, $f = 1.0\text{ MHz}$)

Symbol	Parameter ⁽¹⁾	Condition	Max.	Unit
CIN	Input Capacitance	VIN = 0V	10	pF
COU	Output Capacitance	VOUT = 0V	10	pF

NOTE:

2677 tbl 03

- These parameters are sampled and not 100% tested.

RECOMMENDED DC OPERATING CONDITIONS

Symbol	Parameter	Min.	Typ.	Max.	Unit
VCCM	Military Supply Voltage	4.5	5.0	5.5	V
VCCC	Commercial Supply Voltage	4.5	5.0	5.5	V
GND	Supply Voltage	0	0	0	V
VIH	Input High Voltage Commercial	2.0	—	—	V
VIH	Input High Voltage Military	2.2	—	—	V
VIL ⁽¹⁾	Input Low Voltage Commercial and Military	—	—	0.8	V

NOTE:

2677 tbl 05

- 1.5V undershoots are allowed for 10ns once per cycle.

DC ELECTRICAL CHARACTERISTICS — IDT72021(Commercial: $V_{CC} = 5.0V \pm 10\%$, $T_A = 0^\circ\text{C}$ to $+70^\circ\text{C}$; Military: $V_{CC} = 5V \pm 10\%$, $T_A = -55^\circ\text{C}$ to $+125^\circ\text{C}$)

Symbol	Parameter	IDT72021 Commercial $t_A = 25,35\text{ns}$			IDT72021 Military $t_A = 30,40\text{ns}$			IDT72021 Commercial $t_A = 50\text{ns}$			IDT72021 Military $t_A = 50\text{ns}$			Unit
		Min.	Typ.	Max.	Min.	Typ.	Max.	Min.	Typ.	Max.	Min.	Typ.	Max.	
$I_{LI}^{(1)}$	Input Leakage Current (Any Input)	-1	—	1	-10	—	10	-1	—	1	-10	—	10	μA
$I_{LO}^{(2)}$	Output Leakage Current	-10	—	10	-10	—	10	-10	—	10	-10	—	10	μA
V_{OH}	Output Logic "1" Voltage $I_{OH} = -2\text{mA}$	2.4	—	—	2.4	—	—	2.4	—	—	2.4	—	—	V
V_{OL}	Output Logic "0" Voltage $I_{OL} = 8\text{mA}$	—	—	0.4	—	—	0.4	—	—	0.4	—	—	0.4	V
$I_{CC1}^{(3,4)}$	Active Power Supply Current	—	—	120	—	—	140	—	50	80	—	70	100	mA
$I_{CC2}^{(3)}$	Standby Current ($\bar{R} = \bar{W} = \bar{RS} = \bar{FL}/\bar{RT} = V_{IH}$)	—	—	12	—	—	20	—	5	8	—	8	15	mA
$I_{CC3}^{(3)}$	Power Down Current (All Input = $V_{CC} - 0.2V$)	—	—	500	—	—	900	—	—	500	—	—	900	μA

2677 tbl 06

DC ELECTRICAL CHARACTERISTICS — IDT72031, IDT72041(Commercial: $V_{CC} = 5.0V \pm 10\%$, $T_A = 0^\circ\text{C}$ to $+70^\circ\text{C}$; Military: $V_{CC} = 5V \pm 10\%$, $T_A = -55^\circ\text{C}$ to $+125^\circ\text{C}$)

Symbol	Parameter	IDT72031 IDT72041 Commercial $t_A = 35,50\text{ns}$			IDT72031 IDT72041 Military $t_A = 40,50\text{ns}$			Unit
		Min.	Typ.	Max.	Min.	Typ.	Max.	
$I_{LI}^{(1)}$	Input Leakage Current (Any Input)	-1	—	1	-10	—	10	μA
$I_{LO}^{(2)}$	Output Leakage Current	-10	—	10	-10	—	10	μA
V_{OH}	Output Logic "1" Voltage $I_{OUT} = -2\text{mA}$	2.4	—	—	2.4	—	—	V
V_{OL}	Output Logic "0" Voltage $I_{OUT} = 8\text{mA}$	—	—	0.4	—	—	0.4	V
$I_{CC1}^{(3,5)}$	Active Power Supply Current	—	75	120	—	100	150	mA
$I_{CC2}^{(3)}$	Standby Current ($\bar{R} = \bar{W} = \bar{RS} = \bar{FL}/\bar{RT} = V_{IH}$)	—	8	12	—	12	25	mA
$I_{CC3}^{(3)}$	Power Down Current (All Input = $V_{CC} - 0.2V$)	—	—	2	—	—	4	mA

NOTES:

- Measurements with $0.4 \leq V_{IN} \leq V_{CC}$.
- $\bar{R} \geq V_{IH}$, $0.4 \leq V_{OUT} \leq V_{CC}$.
- I_{CC} measurements are made with $\bar{OE} = \text{HIGH}$.
- Tested at $f = 20\text{MHz}$.
- Tested at $f = 15.3\text{MHz}$.

2677 tbl 07

AC ELECTRICAL CHARACTERISTICS — IDT72021⁽¹⁾

(Commercial: VCC = 5.0V±10%, TA = 0°C to +70°C; Military: VCC = 5V±10%, TA = -55°C to +125°C)

Symbol	Parameter	Com'l		Mil.		Com'l		Mil.		Com'l & Mil.		Unit
		72021L25		72021L30		72021L35		72021L40		72021L50		
		Min.	Max.	Min.	Max.	Min.	Max.	Min.	Max.	Min.	Max.	
fS	Shift Frequency	—	28.5	—	25	—	22.2	—	20	—	15	MHz
tRC	\bar{R} Cycle Time	35	—	40	—	45	—	50	—	65	—	ns
tA	Access Time	—	25	—	30	—	35	—	40	—	50	ns
tRR	\bar{R} Recovery Time	10	—	10	—	10	—	10	—	15	—	ns
tRPW	\bar{R} Pulse Width ⁽²⁾	25	—	30	—	35	—	40	—	50	—	ns
tRLZ	\bar{R} Pulse LOW to Data Bus at Low-Z ⁽³⁾	5	—	5	—	5	—	5	—	10	—	ns
tWLZ	\bar{W} Pulse HIGH to Data Bus at Low-Z ^(3,4)	5	—	5	—	5	—	5	—	5	—	ns
tDV	Data Valid from \bar{R} Pulse HIGH	5	—	5	—	5	—	5	—	5	—	ns
tRHZ	\bar{R} Pulse HIGH to Data Bus at High-Z ⁽³⁾	—	18	—	20	—	20	—	25	—	30	ns
tWC	\bar{W} Cycle Time	35	—	40	—	45	—	50	—	65	—	ns
tWPW	\bar{W} Pulse Width ⁽²⁾	25	—	30	—	35	—	40	—	50	—	ns
tWR	\bar{W} Recovery Time	10	—	10	—	10	—	10	—	15	—	ns
tDS	Data Set-up Time	15	—	18	—	18	—	20	—	30	—	ns
tDH	Data Hold Time	0	—	0	—	0	—	0	—	5	—	ns
tRSC	$\bar{R}\bar{S}$ Cycle Time	35	—	40	—	45	—	50	—	65	—	ns
tRS	$\bar{R}\bar{S}$ Pulse Width ⁽²⁾	25	—	30	—	35	—	40	—	50	—	ns
tRSS	$\bar{R}\bar{S}$ Set-up Time	25	—	30	—	35	—	40	—	50	—	ns
tRSR	$\bar{R}\bar{S}$ Recovery Time	10	—	10	—	10	—	10	—	15	—	ns
tRTC	$\bar{R}\bar{T}$ Cycle Time	35	—	40	—	45	—	50	—	65	—	ns
tRT	$\bar{R}\bar{T}$ Pulse Width ⁽²⁾	25	—	30	—	35	—	40	—	50	—	ns
tRTR	$\bar{R}\bar{T}$ Recovery Time	10	—	10	—	10	—	10	—	15	—	ns
tRSF1	$\bar{R}\bar{S}$ to $\bar{E}\bar{F}$ and $\bar{A}\bar{E}\bar{F}$ LOW	—	35	—	40	—	45	—	50	—	65	ns
tRSF2	$\bar{R}\bar{S}$ to $\bar{H}\bar{F}$ and $\bar{F}\bar{F}$ HIGH	—	35	—	40	—	45	—	50	—	65	ns
tREF	\bar{R} LOW to $\bar{E}\bar{F}$ LOW	—	25	—	30	—	30	—	35	—	45	ns
tRFF	\bar{R} HIGH to $\bar{F}\bar{F}$ HIGH	—	25	—	30	—	30	—	35	—	45	ns
tRPE	\bar{R} Pulse Width After $\bar{E}\bar{F}$ HIGH	25	—	30	—	35	—	40	—	50	—	ns
tWEF	\bar{W} HIGH to $\bar{E}\bar{F}$ HIGH	—	25	—	30	—	30	—	35	—	45	ns
tWFF	\bar{W} LOW to $\bar{E}\bar{F}$ LOW	—	25	—	30	—	30	—	35	—	45	ns
tWHF	\bar{W} LOW to $\bar{H}\bar{F}$ LOW	—	35	—	40	—	45	—	50	—	65	ns
tRHF	\bar{R} HIGH to $\bar{H}\bar{F}$ HIGH	—	35	—	40	—	45	—	50	—	65	ns
tWPF	\bar{W} Pulse Width after $\bar{F}\bar{F}$ HIGH	25	—	30	—	35	—	40	—	50	—	ns
tRF	\bar{R} HIGH to Transitioning $\bar{A}\bar{E}\bar{F}$	—	35	—	40	—	45	—	50	—	65	ns
tWF	\bar{W} LOW to Transitioning $\bar{A}\bar{E}\bar{F}$	—	35	—	40	—	45	—	50	—	65	ns
tOEHZ	$\bar{O}\bar{E}$ HIGH to High-Z (Disable) ⁽³⁾	0	12	0	15	0	17	0	20	0	25	ns
tOELZ	$\bar{O}\bar{E}$ LOW to Low-Z (Enable) ⁽³⁾	0	12	0	15	0	17	0	20	0	25	ns
tAOE	$\bar{O}\bar{E}$ LOW Data Valid (Q0–Q8)	—	15	—	18	—	20	—	25	—	30	ns

NOTES:

1. Timings referenced as in AC Test Conditions.
2. Pulse widths less than minimum value are not allowed.
3. Values guaranteed by design, not currently tested.
4. Only applies to read data flow-through mode.

2677 tbl 08

AC ELECTRICAL CHARACTERISTICS — IDT72031, IDT72041⁽¹⁾

(Commercial: V_{CC} = 5.0V±10%, T_A = 0°C to +70°C; Military: V_{CC} = 5V±10%, T_A = -55°C to +125°C)

Symbol	Parameter	Com'l		Mil.		Com'l and Mil.		Unit
		72031L35 72041L35		72031L40 72041L40		72031L50 72041L50		
		Min.	Max.	Min.	Max.	Min.	Max.	
f _S	Shift Frequency	—	22.2	—	20	—	15	MHz
t _{RC}	\bar{R} Cycle Time	45	—	50	—	65	—	ns
t _A	Access Time	—	35	—	40	—	50	ns
t _{RR}	\bar{R} Recovery Time	10	—	10	—	15	—	ns
t _{RPW}	\bar{R} Pulse Width ⁽²⁾	35	—	40	—	50	—	ns
t _{RLZ}	\bar{R} Pulse LOW to Data Bus at Low-Z ⁽³⁾	5	—	5	—	10	—	ns
t _{WLZ}	\bar{W} Pulse HIGH to Data Bus at Low-Z ^(3,4)	5	—	5	—	5	—	ns
t _{DV}	Data Valid from \bar{R} Pulse HIGH	5	—	5	—	5	—	ns
t _{RHZ}	\bar{R} Pulse HIGH to Data Bus at High-Z ⁽³⁾	—	20	—	25	—	30	ns
t _{WC}	\bar{W} Cycle Time	45	—	50	—	65	—	ns
t _{WPW}	\bar{W} Pulse Width ⁽²⁾	35	—	40	—	50	—	ns
t _{WR}	\bar{W} Recovery Time	10	—	10	—	15	—	ns
t _{DS}	Data Set-up Time	18	—	20	—	30	—	ns
t _{DH}	Data Hold Time	0	—	0	—	5	—	ns
t _{RSC}	\bar{RS} Cycle Time	45	—	50	—	65	—	ns
t _{RS}	\bar{RS} Pulse Width ⁽²⁾	35	—	40	—	50	—	ns
t _{RSS}	\bar{RS} Set-up Time	35	—	40	—	50	—	ns
t _{RSR}	\bar{RS} Recovery Time	10	—	10	—	15	—	ns
t _{RTC}	\bar{RT} Cycle Time	45	—	50	—	65	—	ns
t _{RT}	\bar{RT} Pulse Width ⁽²⁾	35	—	40	—	50	—	ns
t _{RTR}	\bar{RT} Recovery Time	10	—	10	—	15	—	ns
t _{RSF1}	\bar{RS} to \bar{EF} and \bar{AEF} LOW	—	45	—	50	—	65	ns
t _{RSF2}	\bar{RS} to \bar{HF} and \bar{FF} HIGH	—	45	—	50	—	65	ns
t _{REF}	\bar{R} LOW to \bar{EF} LOW	—	30	—	35	—	45	ns
t _{RFF}	\bar{R} HIGH to \bar{FF} HIGH	—	30	—	35	—	45	ns
t _{RPE}	\bar{R} Pulse Width After \bar{EF} HIGH	35	—	40	—	50	—	ns
t _{WEF}	\bar{W} HIGH to \bar{EF} HIGH	—	30	—	35	—	45	ns
t _{WFF}	\bar{W} LOW to \bar{EF} LOW	—	30	—	35	—	45	ns
t _{WHF}	\bar{W} LOW to \bar{HF} LOW	—	45	—	50	—	65	ns
t _{RHF}	\bar{R} HIGH to \bar{HF} HIGH	—	45	—	50	—	65	ns
t _{WPF}	\bar{W} Pulse Width after \bar{FF} HIGH	35	—	40	—	50	—	ns
t _{RF}	\bar{R} HIGH to Transitioning \bar{AEF}	—	45	—	50	—	65	ns
t _{WF}	\bar{W} LOW to Transitioning \bar{AEF}	—	45	—	50	—	65	ns
t _{OEZ}	\bar{OE} HIGH to High-Z (Disable) ⁽³⁾	0	17	0	20	0	25	ns
t _{OELZ}	\bar{OE} LOW to Low-Z (Enable) ⁽³⁾	0	17	0	20	0	25	ns
t _{AOE}	\bar{OE} LOW Data Valid (Q ₀ –Q ₈)	—	20	—	25	—	30	ns

NOTES:

1. Timings referenced as in AC Test Conditions.
2. Pulse widths less than minimum value are not allowed.
3. Values guaranteed by design, not currently tested.
4. Only applies to read data flow-through mode.

2677 tbl 09

AC TEST CONDITIONS

Input Pulse Levels	GND to 3.0V
Input Rise/Fall Times	5ns
Input Timing Reference Levels	1.5V
Output Reference Levels	1.5V
Output Load	See Figure 1

2677 tbl 10

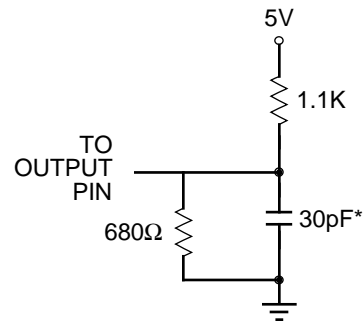

2677 drw 04

or equivalent circuit

Figure 1. Output Load

* Includes scope and jig capacitances.

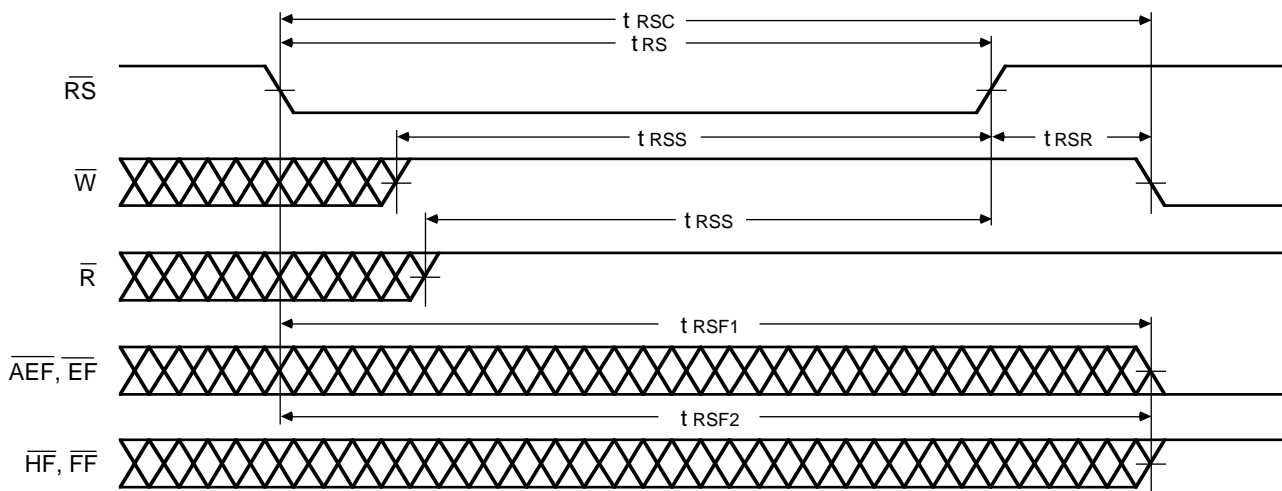

2677 drw 05

Figure 2. Reset

NOTES:

1. EF, FF, HF, and AEF may change status during Reset, but flags will be valid at trsc.
2. W and R = VIH around the rising edge of RS.

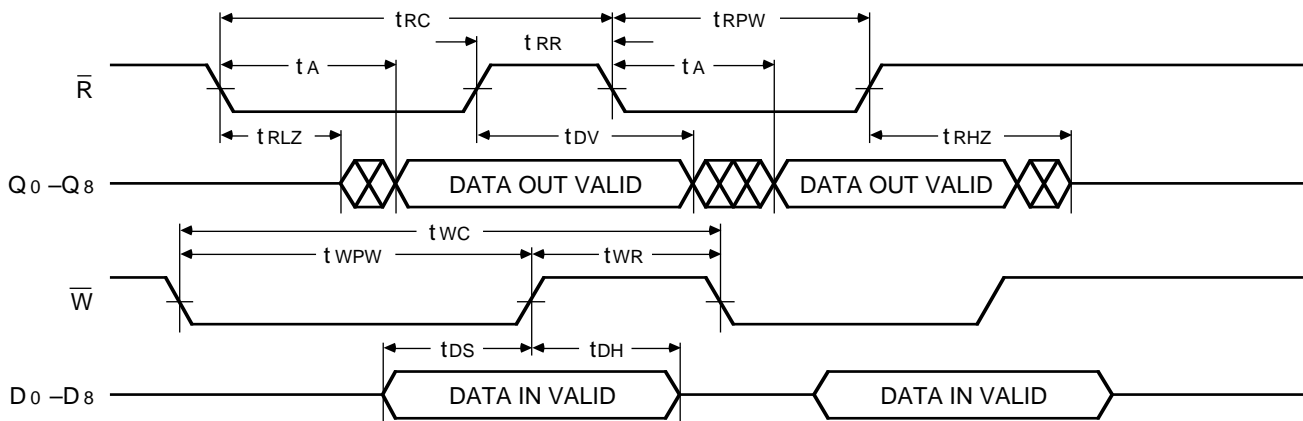

2677 drw 06

Figure 3. Asynchronous Write and Read Operation

NOTE:

1. Assume OE-bar is asserted LOW.

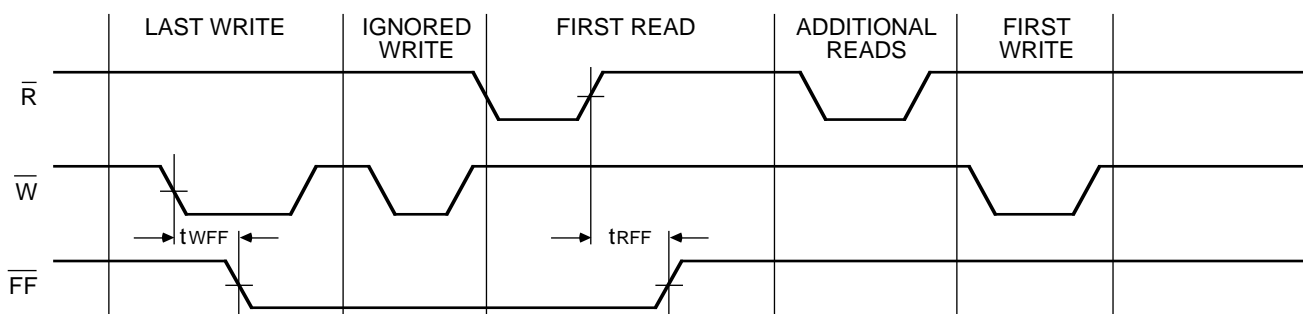

2677 drw 07

Figure 4. Full Flag From Last Write to First Read

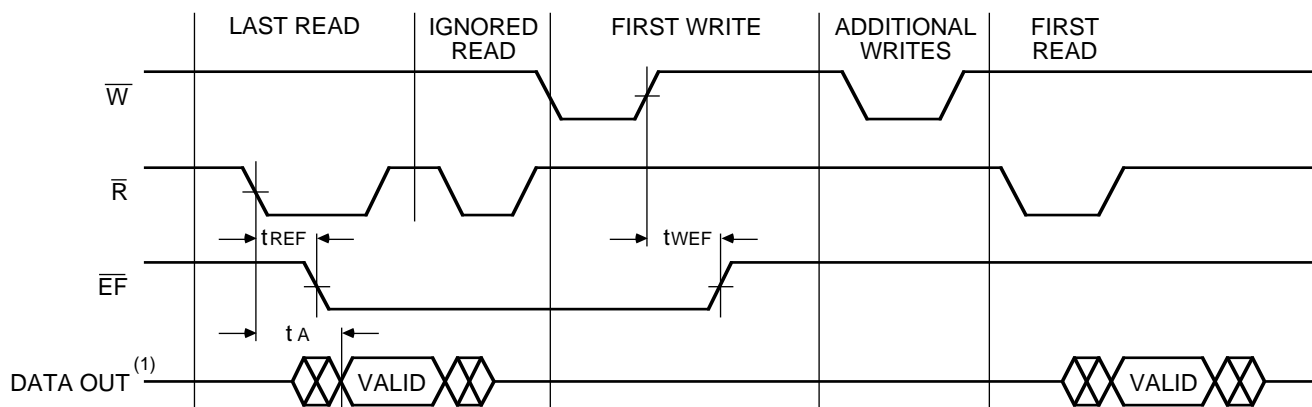

2677 drw 08

Figure 5. Empty Flag From Last Read to First Write

NOTE:

1. Assume \overline{OE} is asserted LOW.

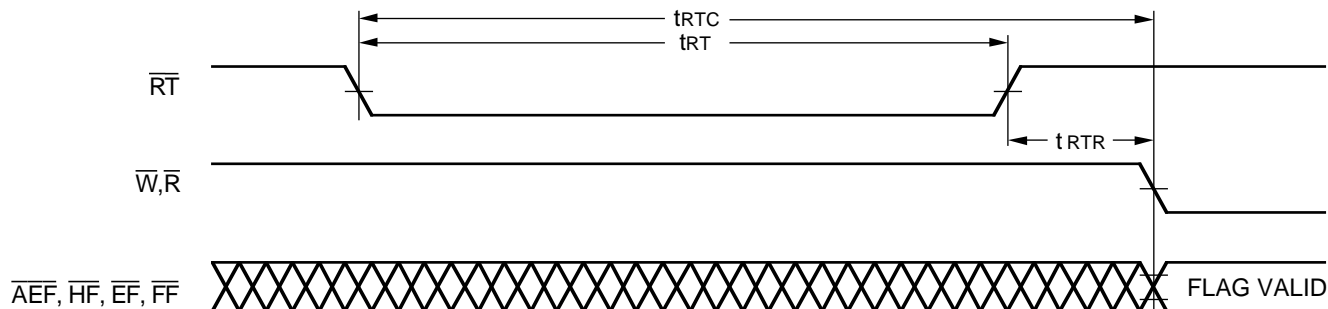

2677 drw 09

Figure 6. Retransmit

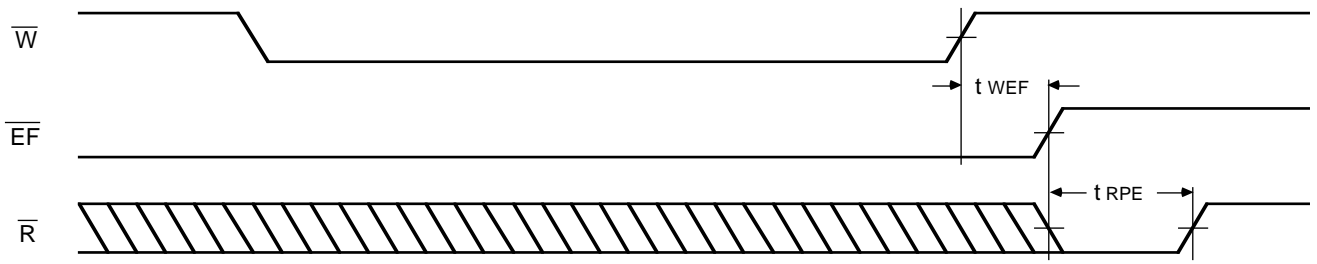

2677 drw 10

Figure 7. Empty Flag Timing
 Figure 9. Almost-Empty/Almost-Full Flag and Half-Full Timings

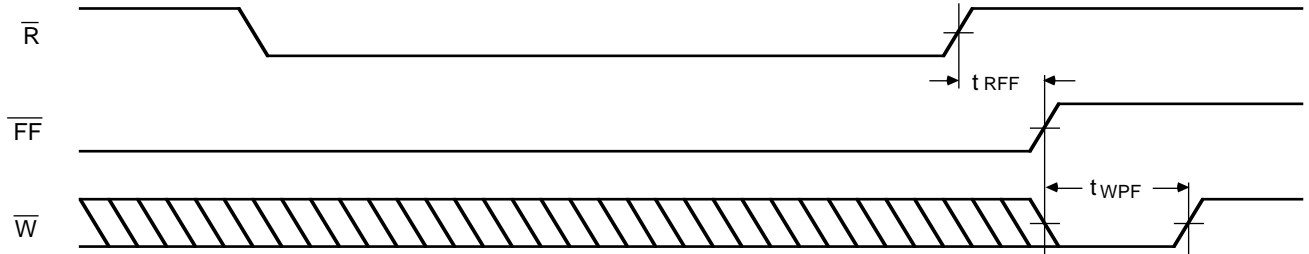

2677 drw 11

Figure 8. Full Flag Timing

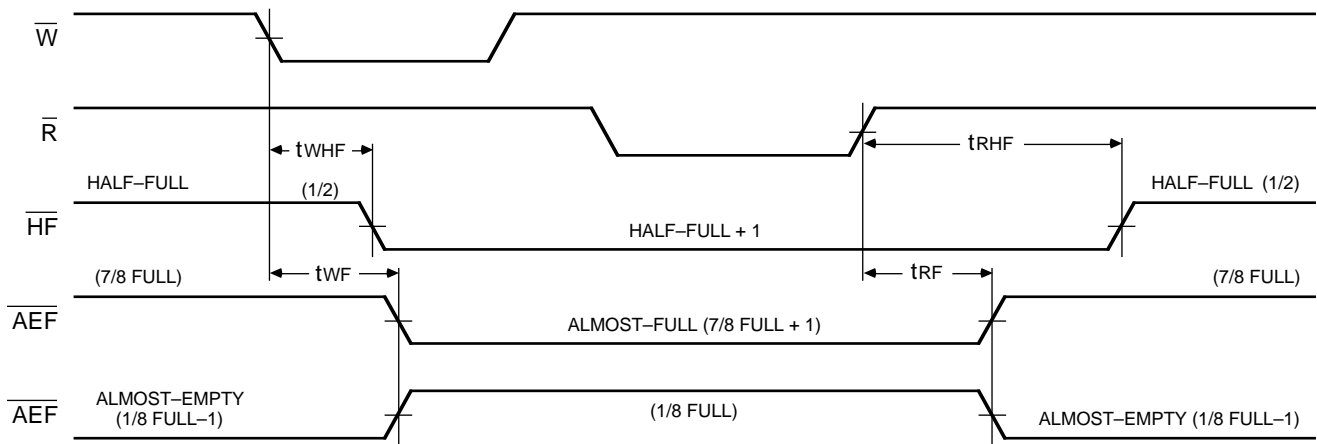

2677 drw 12

Figure 9. Almost-Empty/Almost-Full Flag and Half-Full Timings

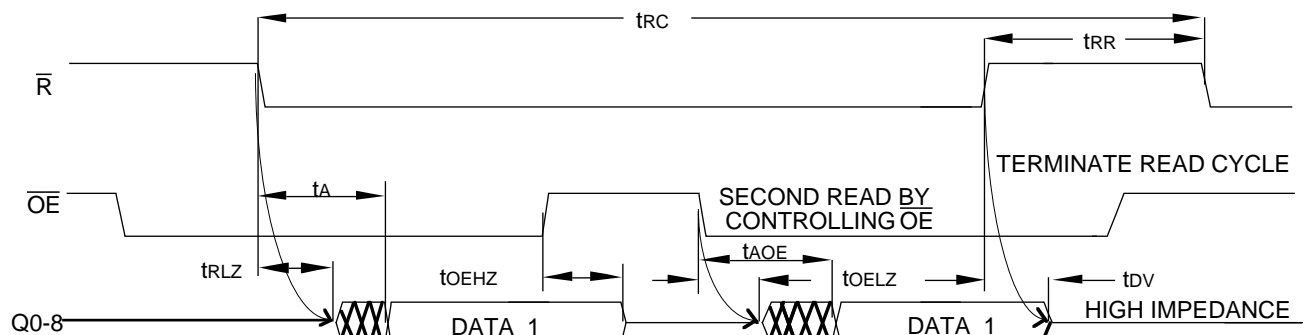

2677 drw 13

Figure 10. Output Enable and Read Operation Timings

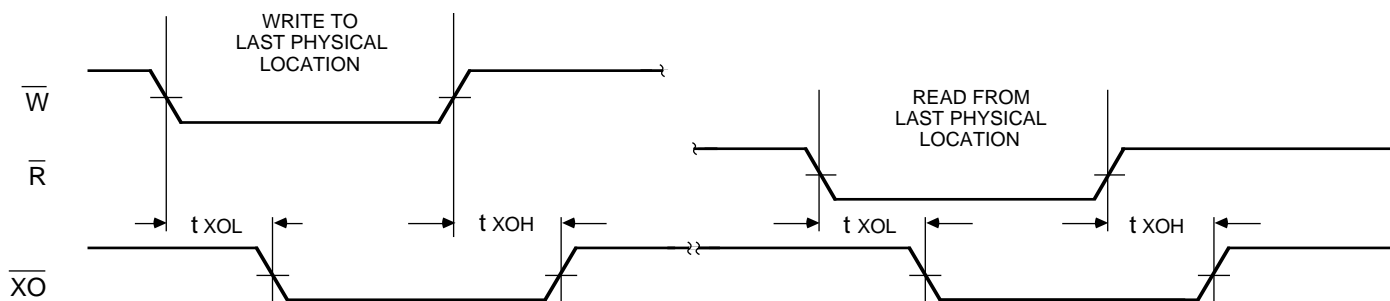

2677 drw 14

Figure 11. Expansion Out

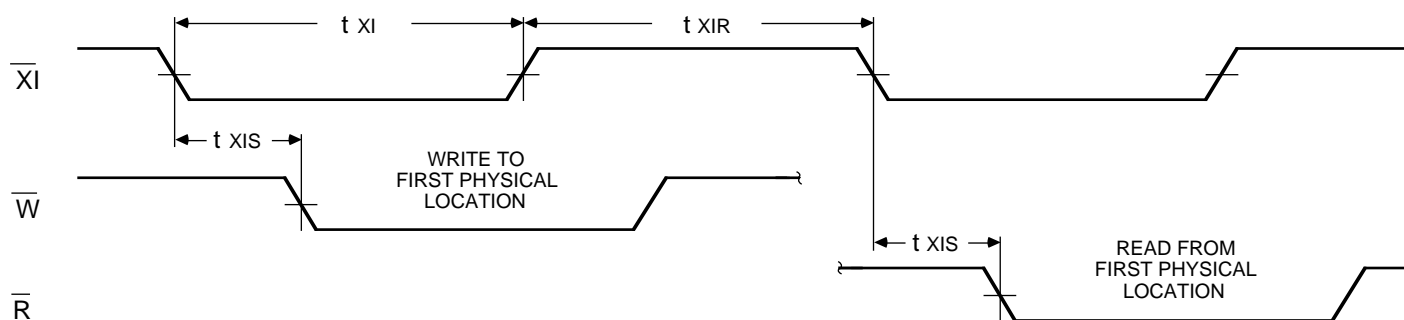

2677 drw 15

Figure 12. Expansion In

OPERATING CONFIGURATIONS

SINGLE DEVICE CONFIGURATION

The IDT72021/031/041 is in the Single Device Configuration when the Expansion In ($\bar{X}I$) control input is grounded (see Figure 13).

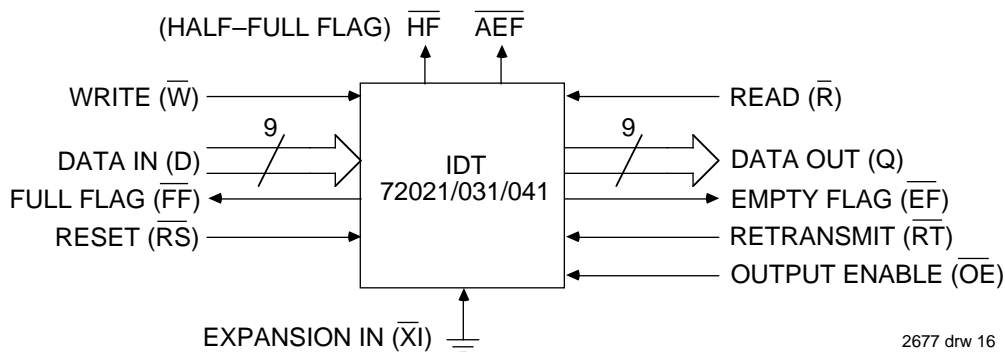

2677 drw 16

Figure 13. Block Diagram of Single 1K/2K/4K x 9 FIFO

WIDTH EXPANSION CONFIGURATION

Word width may be increased simply by connecting the corresponding input control signals of multiple devices. Status flags (\overline{EF} , \overline{FF} , \overline{HF} , and \overline{AEF}) can be detected from any one

device. Figure 14 demonstrates an 18-bit word width by using two IDT72021/031/041 devices. Any word width can be attained by adding additional IDT72021/031/041s.

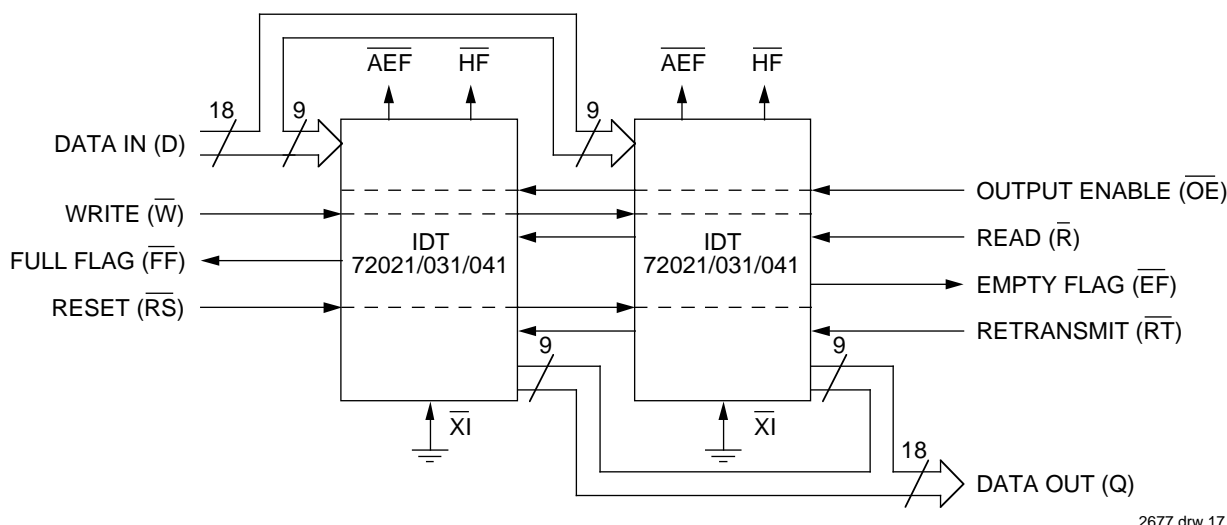

Figure 14. Block Diagram of 1K/2K/4K x 18 FIFO Memory Used in Width Expansion Configuration

NOTE:

1. Flag detection is accomplished by monitoring the \overline{FF} , \overline{EF} , \overline{HF} and \overline{AEF} signals on either (any) device used in the width expansion configuration. Do not connect any output signals together.

DEPTH EXPANSION (DAISY CHAIN) MODE

The IDT72021/031/041 can easily be adapted to applications when the requirements are for greater than 1K/2K/4K words. Figure 15 demonstrates Depth Expansion using three IDT72021/031/041s. Any depth can be attained by adding additional devices. The IDT72021/031/041 operates in the Depth Expansion configuration when the following conditions are met:

1. The first device must be designed by grounding the First Load (\overline{FL}) control input.
2. All other devices must have \overline{FL} in the HIGH state.
3. The Expansion Out (\overline{XO}) pin of each device must be tied to the Expansion In (\overline{XI}) pin of the next device. See Figure 15.
4. External logic is needed to generate a composite Full Flag (\overline{FF}) and Empty Flag (\overline{EF}). This requires the ORing of all \overline{EF} s and ORing of all \overline{FF} s (i.e. all must be set to generate the correct composite \overline{FF} or \overline{EF}). See Figure 15.
5. The Retransmit (\overline{RT}) function and Half-Full Flag (\overline{HF}) are not available in the Depth Expansion Mode. For additional information refer to Tech Note 9: "Cascading FIFOs or FIFO Modules".

COMPOUND EXPANSION MODE

The two expansion techniques described above can be applied together in a straight forward manner to achieve large FIFO arrays (see Figure 16).

BIDIRECTIONAL MODE

Applications which require data buffering between two systems (each system capable of Read and Write operations) can be achieved by pairing IDT72021/031/041s as shown in Figure 17. Care must be taken to assure that the appropriate flag is monitored by each system (i.e., \overline{FF} is monitored on the device where \overline{W} is used; \overline{EF} is monitored on the device where \overline{R} is used). Both Depth Expansion and Width Expansion may be used in this mode.

DATA FLOW-THROUGH MODES

Two types of flow-through modes are permitted: a read flow-through and write flow-through mode. For the read flow-through mode (Figure 18), the FIFO permits the reading of a single word after writing one word of data into an empty FIFO. The data is enabled on the bus in ($t_{WEF} + t_A$) ns after the rising edge of \overline{W} , called the first write edge. It remains on the bus until the \overline{R} line is raised from LOW-to-HIGH, after which the bus would go into a three-state mode after t_{RHZ} ns. The \overline{EF} line would have a pulse showing temporary deassertion and then would be asserted. In the interval of time that \overline{R} was LOW, more words can be written to the FIFO (the subsequent writes after the first write edge will be deassert the Empty Flag); however, the same word (written on the first write edge), presented to the output bus as the read pointer, would not be incremented when \overline{R} was LOW. On toggling \overline{R} , the other words that are written to the FIFO will appear on the output bus as in the read cycle timings.

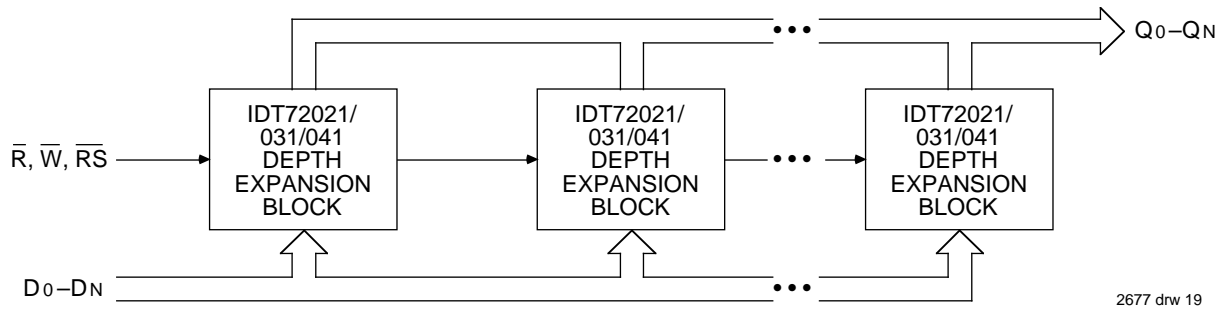

2677 drw 19

Figure 16. Compound FIFO Expansion

NOTES:

1. For depth expansion block see section od Depth Expansion and Figure 15.
2. For Flag detection see section on Width Expansion and Figure 14.

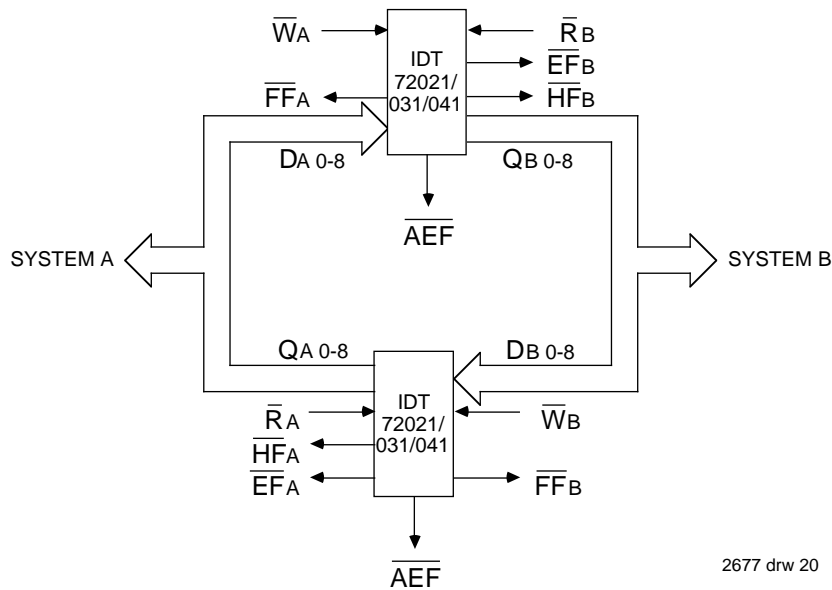

2677 drw 20

Figure 17. Bidirectional FIFO Mode

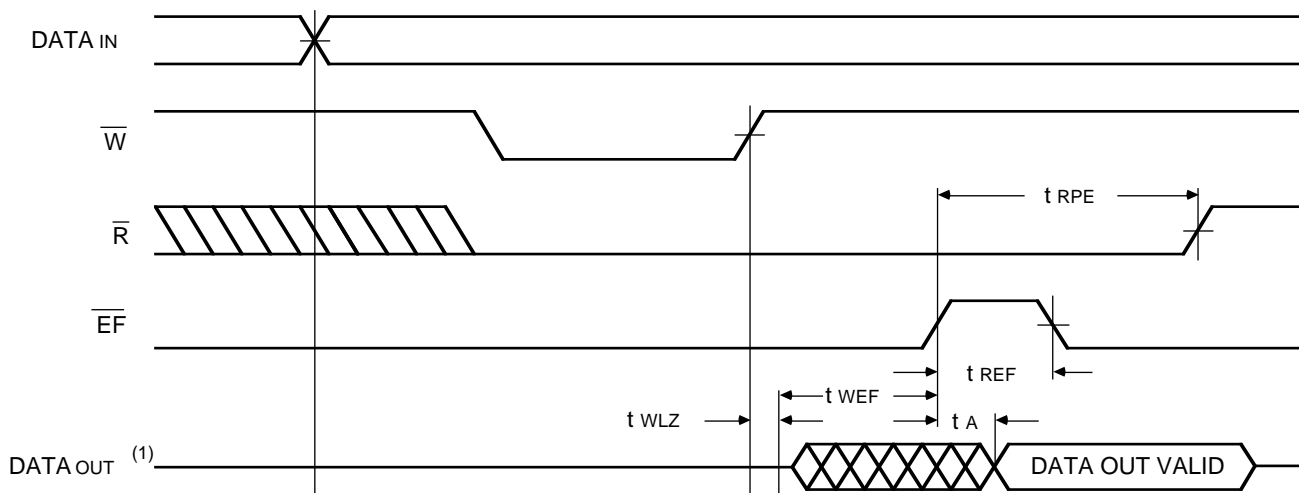

2677 drw 21

Figure 18. Read Data Flow-Through Mode

NOTE:

1. Assume &OEbar is asserted LOW.

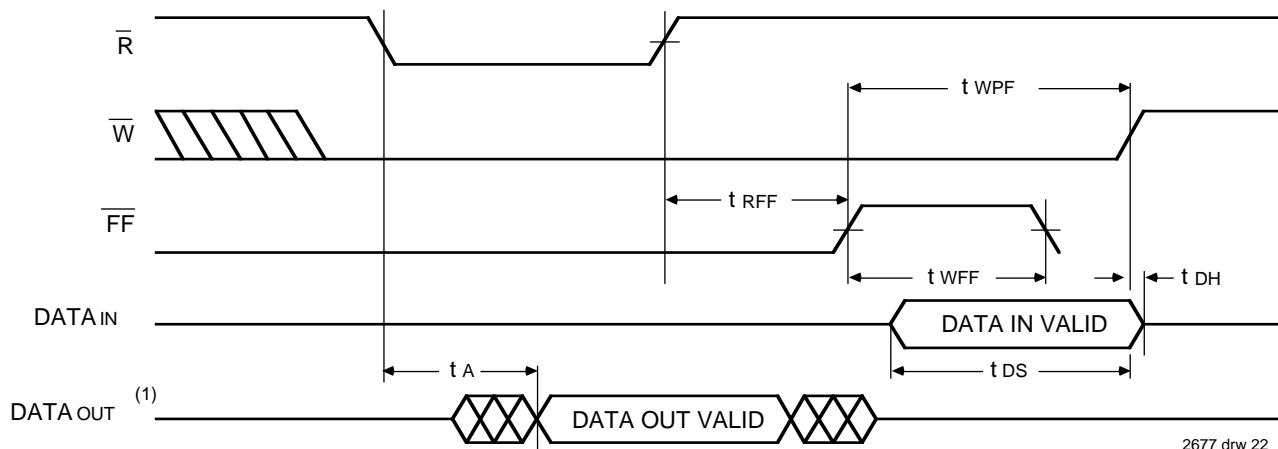
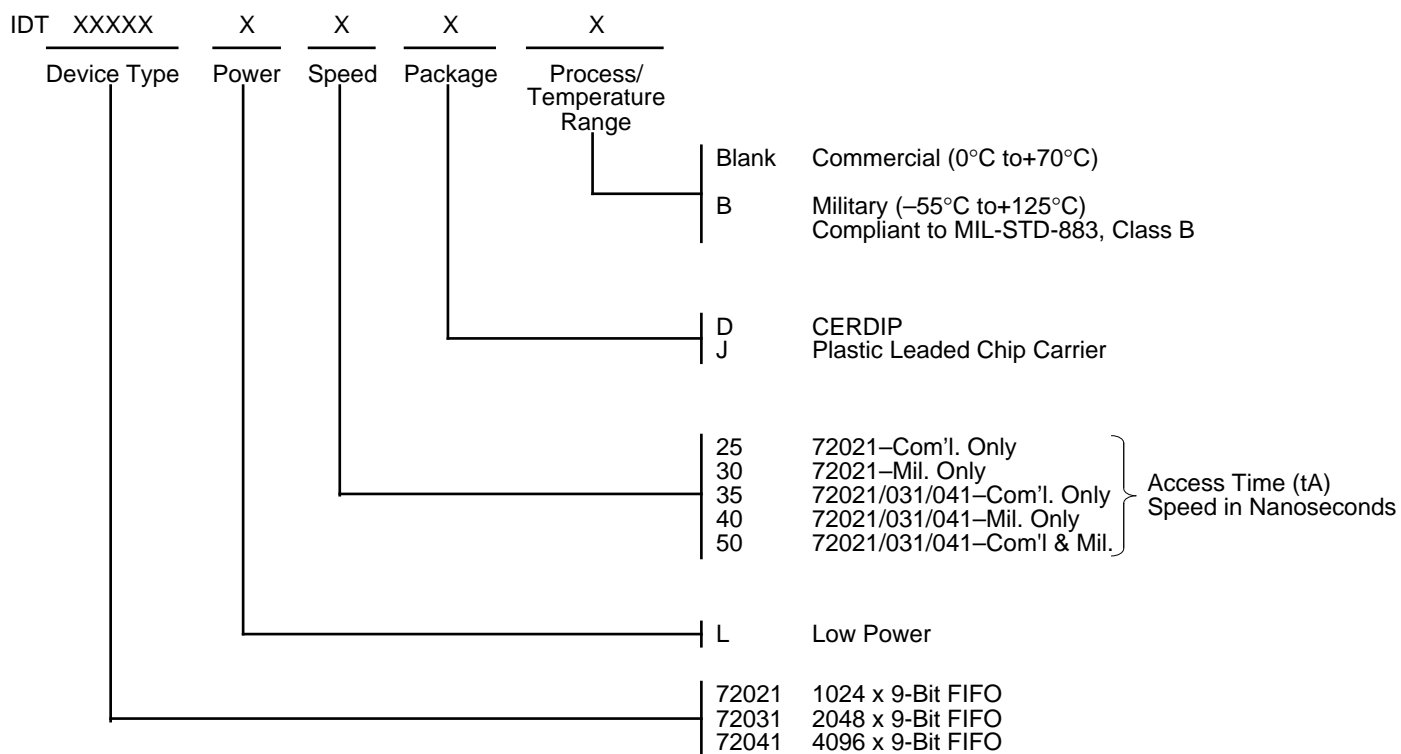

Figure 19. Write Data Flow-Through Mode

NOTE:

1. Assume \bar{OE} is asserted LOW.

ORDERING INFORMATION



2677 drw 23

This datasheet has been downloaded from:

www.DatasheetCatalog.com

Datasheets for electronic components.



LittleDiode supplies new, hard to find or obsolete electronic components and semiconductors all over the world.

With over two million different components listed you are sure to find the part you need.

Feel free to visit us today at our online store:

LittleDiode.com

Looking forward to providing you with the best possible service.