

CD40192BM/CD40192BC Synchronous 4-Bit Up/Down Decade Counter

CD40193BM/CD40193BC Synchronous 4-Bit Up/Down Binary Counter

General Description

These up/down counters are monolithic complementary MOS (CMOS) integrated circuits. The CD40192BM and CD40192BC are BCD counters, while the CD40193BM and CD40193BC are binary counters.

Counting up and counting down is performed by two count inputs, one being held high while the other is clocked. The outputs change on the positive-going transition of this clock.

These counters feature preset inputs that are enabled when load is a logical "0" and a clear which forces all outputs to "0" when it is at logical "1". The counters also have carry and borrow outputs so that they can be cascaded using no external circuitry.

All inputs are protected against damage due to static discharge by clamps to V_{DD} and V_{SS} .

Features

- Wide supply voltage range 3V to 15V
- High noise immunity 0.45 V_{DD} (typ.)
- Low power TTL compatibility Fan out of 2 driving 74LS or 1 driving 74LS
- Carry and borrow outputs for easy expansion to N-bit by cascading
- Asynchronous clear MM54C192/MM74C192 and MM54C193/MM74C193
- Equivalent to

Connection Diagram

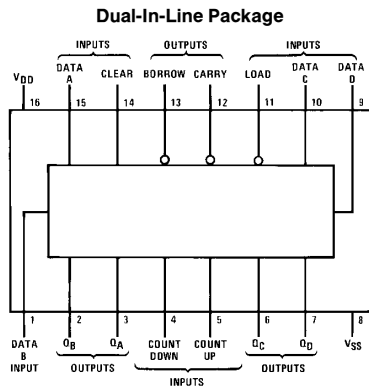

Order Number CD40192B or CD40193

TL/F/5988-1

Top View

Cascading Packages

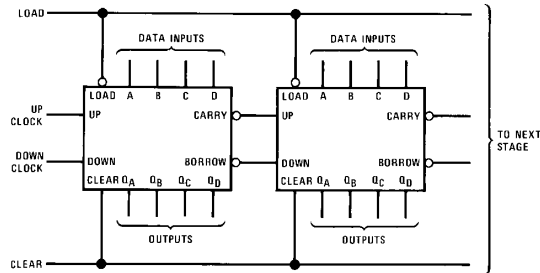

TL/F/5988-2

CD40192BM/CD40192BC Synchronous 4-Bit Up/Down Decade Counter
 CD40193BM/CD40193BC Synchronous 4-Bit Up/Down Binary Counter

Absolute Maximum Ratings (Notes 1 & 2)

If Military/Aerospace specified devices are required, please contact the National Semiconductor Sales Office/Distributors for availability and specifications.

DC Supply Voltage (V_{DD})	-0.5 to +18 V_{DC}
Input Voltage (V_{IN})	-0.5 to V_{DD} + 0.5 V_{DC}
Storage Temperature Range (T_S)	-65°C to +150°C
Power Dissipation (P_D)	
Dual-In-Line	700 mW
Small Outline	500 mW
Lead Temperature (T_L)	
(Soldering, 10 seconds)	260°C

Recommended Operating Conditions (Note 2)

DC Supply Voltage (V_{DD})	3 to 15 V_{DC}
Input Voltage (V_{IN})	0 to V_{DD} V_{DC}
Operating Temperature Range (T_A)	
CD40192BM, CD40193BM	-55°C to +125°C
CD40192BC, CD40193BC	-40°C to +85°C

DC Electrical Characteristics CD40192BM/CD40193BM (Note 2)

Symbol	Parameter	Conditions	-55°C		+25°C			+125°C		Units
			Min	Max	Min	Typ	Max	Min	Max	
I_{DD}	Quiescent Device Current	$V_{DD} = 5V, V_{IN} = V_{DD}$ or V_{SS}		5			5		150	μA
		$V_{DD} = 10V, V_{IN} = V_{DD}$ or V_{SS}		10			10		300	μA
		$V_{DD} = 15V, V_{IN} = V_{DD}$ or V_{SS}		20			20		600	μA
V_{OL}	Low Level Output Voltage	$V_{DD} = 5V$		0.05			0.05		0.05	V
		$V_{DD} = 10V$		0.05			0.05		0.05	V
		$V_{DD} = 15V$		0.05			0.05		0.05	V
V_{OH}	High Level Output Voltage	$V_{DD} = 5V$	4.95		4.95			4.95		V
		$V_{DD} = 10V$	9.95		9.95			9.95		V
		$V_{DD} = 15V$	14.95		14.95			14.95		V
V_{IL}	Low Level Input Voltage	$V_{DD} = 5V, V_O = 0.5V$ or 4.5V		1.5			1.5		1.5	V
		$V_{DD} = 10V, V_O = 1V$ or 9V		3.0			3.0		3.0	V
		$V_{DD} = 15V, V_O = 1.5V$ or 13.5V		4.0			4.0		4.0	V
V_{IH}	High Level Input Voltage	$V_{DD} = 5V, V_O = 0.5V$ or 4.5V	3.5		3.5			3.5		V
		$V_{DD} = 10V, V_O = 1V$ or 9V	7.0		7.0			7.0		V
		$V_{DD} = 15V, V_O = 1.5V$ or 13.5V	11.0		11.0			11.0		V
I_{OL}	Low Level Output Current (Note 3)	$V_{DD} = 5V, V_O = 0.4V$	0.64		0.51	0.88		0.36		mA
		$V_{DD} = 10V, V_O = 0.5V$	1.6		1.3	2.25		0.9		mA
		$V_{DD} = 15V, V_O = 1.5V$	4.2		3.4	8.8		2.4		mA
I_{OH}	High Level Output Current (Note 3)	$V_{DD} = 5V, V_O = 4.6V$	-0.64		-0.51	-0.88		-0.36		mA
		$V_{DD} = 10V, V_O = 9.5V$	-1.6		-1.3	-2.25		-0.9		mA
		$V_{DD} = 15V, V_O = 13.5V$	-4.2		-3.4	-8.8		-2.4		mA
I_{IN}	Input Current	$V_{DD} = 15V, V_{IN} = 0V$		-0.1		-10^{-5}	-0.1		-1.0	μA
		$V_{DD} = 15V, V_{IN} = 15V$		0.1		10^{-5}	0.1		1.0	μA

DC Electrical Characteristics CD40192BC/CD40193BC (Note 2)

Symbol	Parameter	Conditions	-40°C		+25°C			+85°C		Units
			Min	Max	Min	Typ	Max	Min	Max	
I_{DD}	Quiescent Device Current	$V_{DD} = 5V, V_{IN} = V_{DD}$ or V_{SS}		20			20		150	μA
		$V_{DD} = 10V, V_{IN} = V_{DD}$ or V_{SS}		40			40		300	μA
		$V_{DD} = 15V, V_{IN} = V_{DD}$ or V_{SS}		80			80		600	μA
V_{OL}	Low Level Output Voltage	$V_{DD} = 5V$		0.05			0.05		0.05	V
		$V_{DD} = 10V$		0.05			0.05		0.05	V
		$V_{DD} = 15V$		0.05			0.05		0.05	V
V_{OH}	High Level Output Voltage	$V_{DD} = 5V$	4.95		4.95			4.95		V
		$V_{DD} = 10V$	9.95		9.95			9.95		V
		$V_{DD} = 15V$	14.95		14.95			14.95		V
V_{IL}	Low Level Input Voltage	$V_{DD} = 5V, V_O = 0.5V$ or 4.5V		1.5			1.5		1.5	V
		$V_{DD} = 10V, V_O = 1V$ or 9V		3.0			3.0		3.0	V
		$V_{DD} = 15V, V_O = 1.5V$ or 13.5V		4.0			4.0		4.0	V
V_{IH}	High Level Input Voltage	$V_{DD} = 5V, V_O = 0.5V$ or 4.5V	3.5		3.5			3.5		V
		$V_{DD} = 10V, V_O = 1V$ or 9V	7.0		7.0			7.0		V
		$V_{DD} = 15V, V_O = 1.5V$ or 13.5V	11.0		11.0			11.0		V
I_{OL}	Low Level Output Current (Note 3)	$V_{DD} = 5V, V_O = 0.4V$	0.52		0.44	0.88		0.36		mA
		$V_{DD} = 10V, V_O = 0.5V$	1.3		1.1	2.25		0.9		mA
		$V_{DD} = 15V, V_O = 1.5V$	3.6		3.0	8.8		2.4		mA

DC Electrical Characteristics CD40192BC/CD40193BC (Note 2) (Continued)

Symbol	Parameter	Conditions	-40°C		+25°C			+85°C		Units
			Min	Max	Min	Typ	Max	Min	Max	
I _{OH}	High Level Output Current (Note 3)	V _{DD} = 5V, V _O = 4.6V	-0.52		-0.44	-0.88		-0.36		mA mA mA
		V _{DD} = 10V, V _O = 9.5V	-1.3		-1.1	-2.25		-0.9		
		V _{DD} = 15V, V _O = 13.5V	-3.6		-3.0	-8.8		-2.4		
I _{IN}	Input Current	V _{DD} = 15V, V _{IN} = 0V		-0.3		-10 ⁻⁵	-0.3		-1.0	μA
		V _{DD} = 15V, V _{IN} = 15V		0.3		10 ⁻⁵	0.3		1.0	μA

AC Electrical Characteristics*

T_A = 25°C, C_L = 50 pF, R_L = 200 kΩ, input t_r = t_f = 20 ns, unless otherwise specified.

Symbol	Parameter	Conditions	Min	Typ	Max	Units
t _{PHL} or t _{PLH}	Propagation Delay Time from Count Up or Count Down to Q	V _{DD} = 5V		250	400	ns
		V _{DD} = 10V		100	160	ns
		V _{DD} = 15V		80	130	ns
t _{PHL} or t _{PLH}	Propagation Delay Time from Count Up to Carry	V _{DD} = 5V		120	200	ns
		V _{DD} = 10V		50	80	ns
		V _{DD} = 15V		40	65	ns
t _{PHL} or t _{PLH}	Propagation Delay Time from Count Down to Borrow	V _{DD} = 5V		120	200	ns
		V _{DD} = 10V		50	80	ns
		V _{DD} = 15V		40	65	ns
t _{SU}	Time Prior to Load That Data Must Be Present	V _{DD} = 5V		100	160	ns
		V _{DD} = 10V		30	50	ns
		V _{DD} = 15V		25	40	ns
t _{PHL}	Propagation Delay Time from Clear to Q	V _{DD} = 5V		130	220	ns
		V _{DD} = 10V		60	100	ns
		V _{DD} = 15V		50	80	ns
t _{PLH} or t _{PHL}	Propagation Delay Time from Load to Q	V _{DD} = 5V		300	480	ns
		V _{DD} = 10V		120	190	ns
		V _{DD} = 15V		95	150	ns
t _{TLH} or t _{THL}	Output Transition Time	V _{DD} = 5V		100	200	ns
		V _{DD} = 10V		50	100	ns
		V _{DD} = 15V		40	80	ns
f _{CL}	Maximum Count Frequency	V _{DD} = 5V	2.5	4		MHz
		V _{DD} = 10V	6	10		MHz
		V _{DD} = 15V	7.5	12.5		MHz
t _{rCL} or t _{fCL}	Maximum Count Rise or Fall Time	V _{DD} = 5V	15			μs
		V _{DD} = 10V	5			μs
		V _{DD} = 15V	1			μs
t _{WH} , t _{WL}	Minimum Count Pulse Width	V _{DD} = 5V		120	200	ns
		V _{DD} = 10V		35	80	ns
		V _{DD} = 15V		28	65	ns
t _{WH}	Minimum Clear Pulse Width	V _{DD} = 5V		300	480	ns
		V _{DD} = 10V		120	190	ns
		V _{DD} = 15V		95	150	ns
t _{WL}	Minimum Load Pulse Width	V _{DD} = 5V		100	160	ns
		V _{DD} = 10V		40	65	ns
		V _{DD} = 15V		32	55	ns
C _{IN}	Average Input Capacitance	Load and Data Inputs (A,B,C,D)		5	7.5	pF
		Count Up, Count Down and Clear		10	15	pF
C _{PD}	Power Dissipation Capacity	(Note 4)		100		pF

*AC Parameters are guaranteed by DC correlated testing.

Note 1: "Absolute Maximum Ratings" are those values beyond which the safety of the device cannot be guaranteed. They are not meant to imply that the devices should be operated at these limits. The table of "Recommended Operating Conditions" and "Electrical Characteristics" provides conditions for actual device operation.

Note 2: V_{SS} = 0V unless otherwise specified.

Note 3: I_{OH} and I_{OL} are tested one output at a time.

Note 4: C_{PD} determines the no load AC power consumption of any CMOS device. For complete explanation, see 54C/74C Family Characteristics application note, AN-90.

Schematic Diagrams

CD40192BM/CD40192BC Synchronous 4-Bit Up/Down Decade Counter

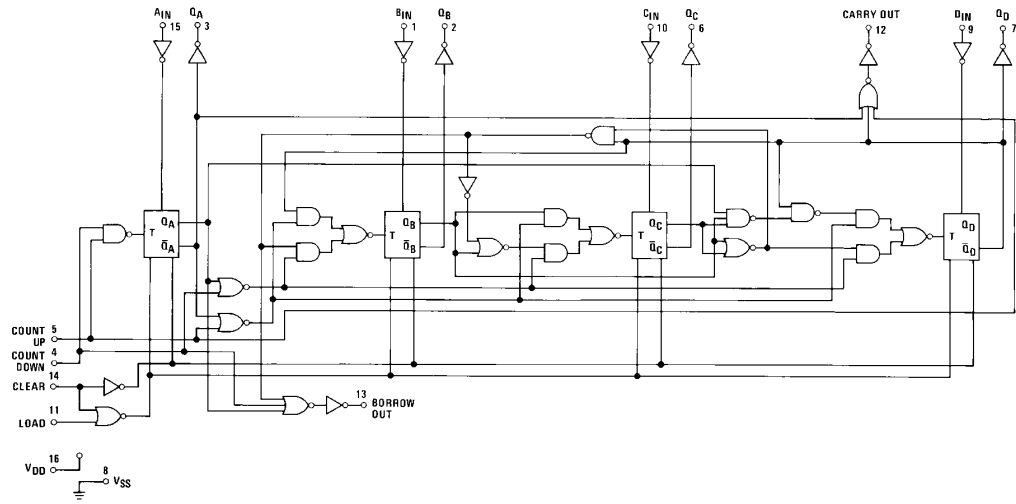

TL/F/5988-3

CD40193BM/CD40193BC Synchronous 4-Bit Up/Down Binary Counter

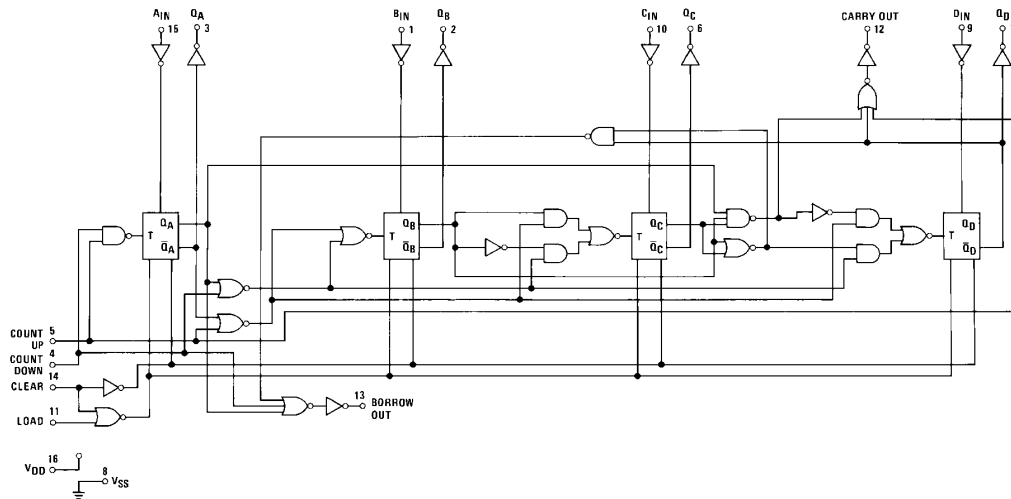

TL/F/5988-4

Timing Diagrams

CD40192BM/CD40192BC

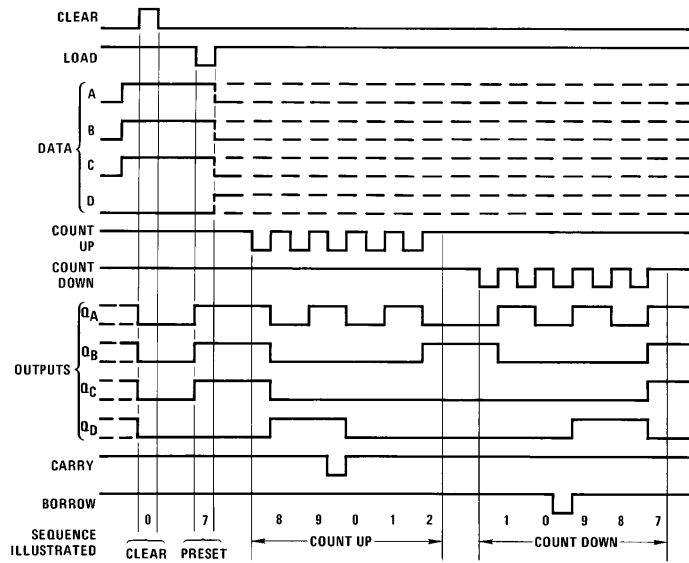

TL/F/5988-5

Sequence:

1. Clear outputs to zero.
2. Load (preset) to BCD seven.
3. Count up to eight, nine, carry, zero, one and two.
4. Count down to one, zero, borrow, nine, eight and seven.

CD40193BM/CD40193BC

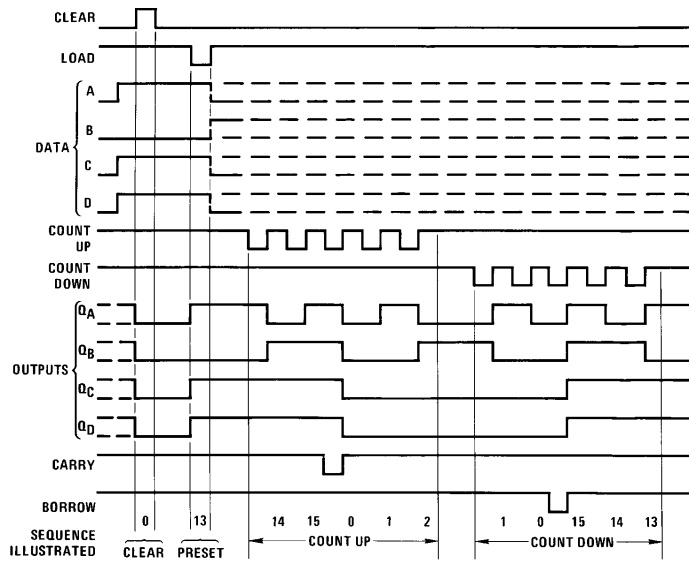

TL/F/5988-6

Sequence:

1. Clear outputs to zero.
2. Load (preset) to binary thirteen.
3. Count up to fourteen, fifteen, carry, zero, one and two.
4. Count down to one, zero, borrow, fifteen, fourteen and thirteen.

CD40192BM/CD40192BC Synchronous 4-Bit Up/Down Decade Counter
CD40193BM/CD40193BC Synchronous 4-Bit Up/Down Binary Counter

Physical Dimensions inches (millimeters)

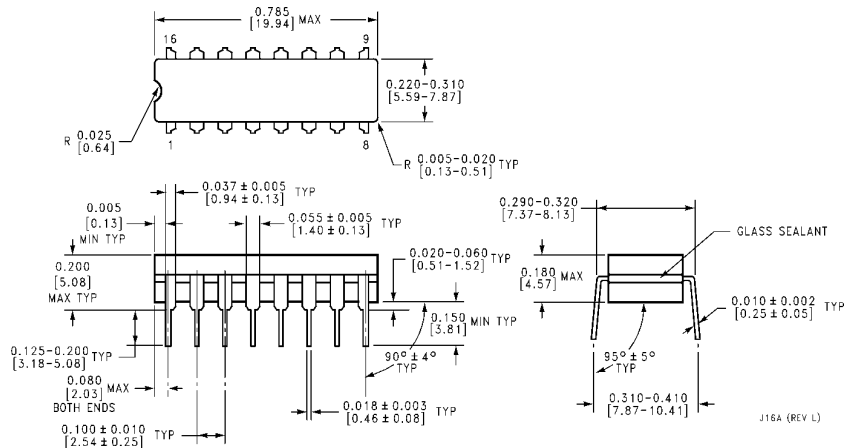

Ceramic Dual-In-Line Package (J)
Order Number CD40192BMJ, CD40192BCJ, CD40193BMJ or CD40193BCJ
NS Package Number J16A

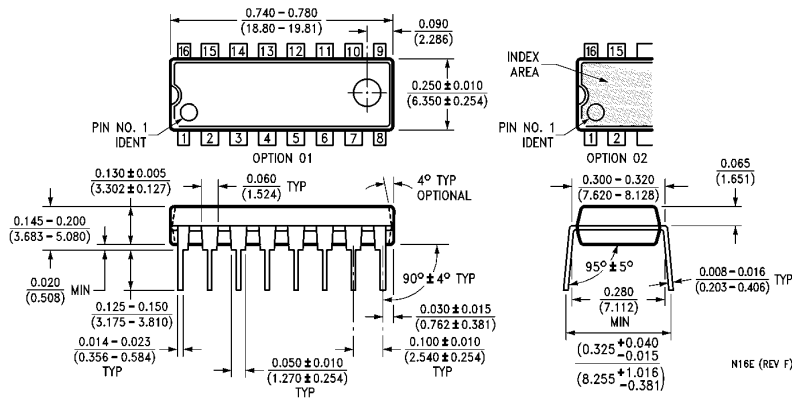

Molded Dual-In-Line Package (N)
Order Number CD40192BMN, CD40192BCN, CD40193BMN or CD40193BCN
NS Package Number N16E

LIFE SUPPORT POLICY

NATIONAL'S PRODUCTS ARE NOT AUTHORIZED FOR USE AS CRITICAL COMPONENTS IN LIFE SUPPORT DEVICES OR SYSTEMS WITHOUT THE EXPRESS WRITTEN APPROVAL OF THE PRESIDENT OF NATIONAL SEMICONDUCTOR CORPORATION. As used herein:

1. Life support devices or systems are devices or systems which, (a) are intended for surgical implant into the body, or (b) support or sustain life, and whose failure to perform, when properly used in accordance with instructions for use provided in the labeling, can be reasonably expected to result in a significant injury to the user.
2. A critical component is any component of a life support device or system whose failure to perform can be reasonably expected to cause the failure of the life support device or system, or to affect its safety or effectiveness.



National Semiconductor Corporation
 1111 West Bardin Road
 Arlington, TX 76017
 Tel: 1(800) 272-9959
 Fax: 1(800) 737-7018

National Semiconductor Europe
 Fax: (+49) 0-180-530 85 86
 Email: cnjwge@tevm2.nsc.com
 Deutsch Tel: (+49) 0-180-530 85 85
 English Tel: (+49) 0-180-532 78 32
 Français Tel: (+49) 0-180-532 93 58
 Italiano Tel: (+49) 0-180-534 16 80

National Semiconductor Hong Kong Ltd.
 19th Floor, Straight Block,
 Ocean Centre, 5 Canton Rd.
 Tsimshatsui, Kowloon
 Hong Kong
 Tel: (852) 2737-1600
 Fax: (852) 2736-9960

National Semiconductor Japan Ltd.
 Tel: 81-043-299-2309
 Fax: 81-043-299-2408

National does not assume any responsibility for use of any circuitry described, no circuit patent licenses are implied and National reserves the right at any time without notice to change said circuitry and specifications.

This datasheet has been downloaded from:

www.DatasheetCatalog.com

Datasheets for electronic components.

National Semiconductor was acquired by Texas Instruments.

http://www.ti.com/corp/docs/investor_relations/pr_09_23_2011_national_semiconductor.html

This file is the datasheet for the following electronic components:

CD40193 - <http://www.ti.com/product/cd40193?HQS=TI-null-null-dscatalog-df-pf-null-ww>

CD40192 - <http://www.ti.com/product/cd40192?HQS=TI-null-null-dscatalog-df-pf-null-ww>



LittleDiode supplies new, hard to find or obsolete electronic components and semiconductors all over the world.

With over two million different components listed you are sure to find the part you need.

Feel free to visit us today at our online store:

LittleDiode.com

Looking forward to providing you with the best possible service.