

TV SOUND IF AMPLIFIER

The KA2101 is a monolithic integrated circuit for TV sound IF amplifier. It contains a IF amplifier, IF limiting, detection, electronic attenuation, audio amplifier and audio driver capabilities.

FEATURES

- Electronic attenuator replaces conventional DC volume.
- Differential peak detector requires one single tuned coil.
- Internal zener diode regulated supply.
- High stability.
- Excellent AM rejection at 4.5 MHz, 5.5 MHz, 6.0 MHz, 6.5 MHz.
- Low harmonic distortion.
- High sensitivity 200 μ V limiting at 4.5 MHz.
- Audio driver capability 6.0 mA_{r.p.}
- Undistorted audio output voltage 7 V_{r.p.}
- Minimum undesirable output signal at maximum attenuation.

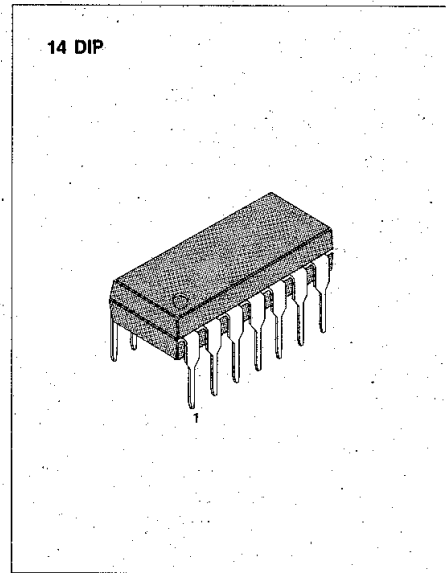

SCHEMATIC DIAGRAM

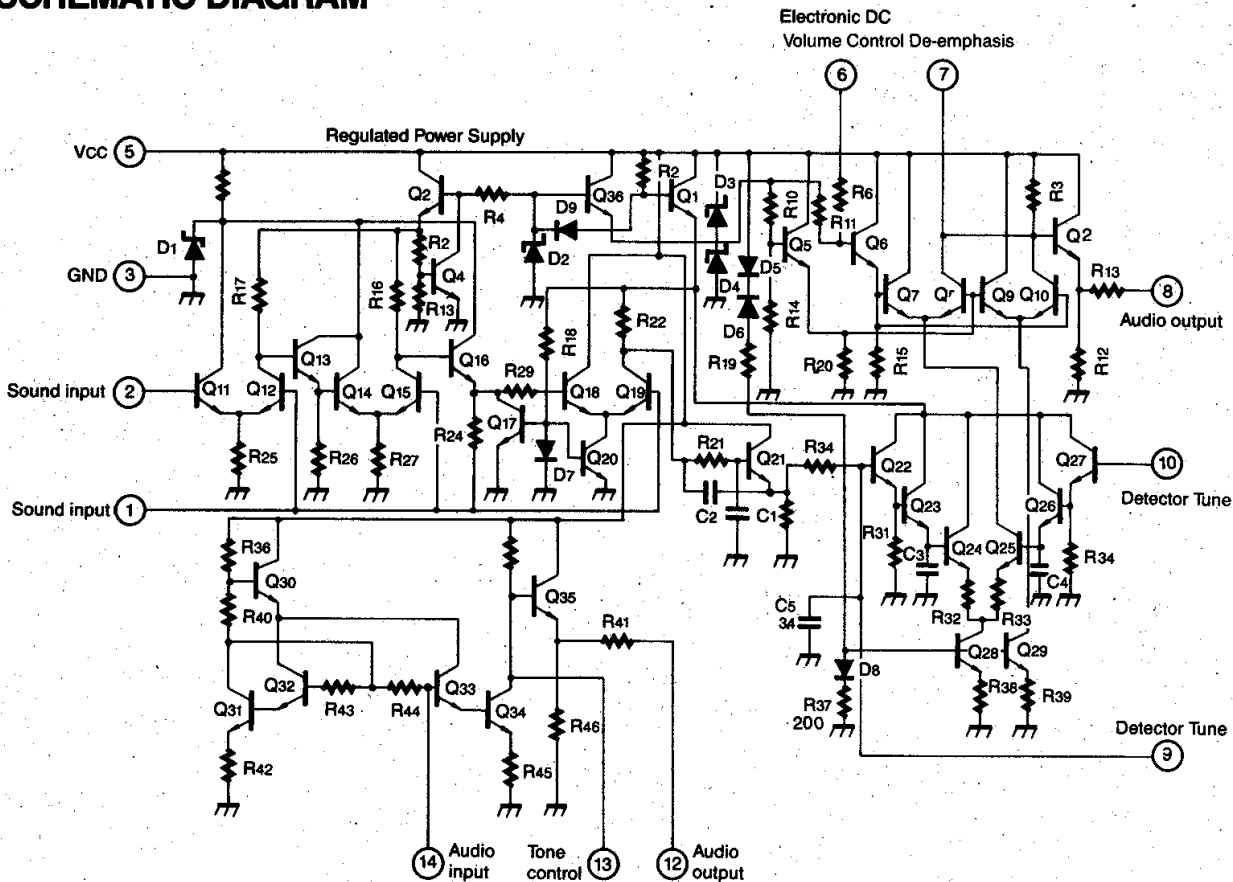

ABSOLUTE MAXIMUM RATINGS ($T_a = 25^\circ\text{C}$)

Characteristic	Symbol	Value	Unit
Input Signal Voltage (Pin 1, Pin 2)	V_{in}	± 3	V
Power Supply Current (Pin 5)	I_s (max)	50	mA
Total Power Dissipation	P_d	625	mW
Derate Above $T_a = 25^\circ\text{C}$		5.0	mW/ $^\circ\text{C}$
Operating Temperature	T_{opr}	$-20 \sim +75$	$^\circ\text{C}$
Storage Temperature	T_{stg}	$-65 \sim +150$	$^\circ\text{C}$

ELECTRICAL CHARACTERISTICS ($T_a = 25^\circ\text{C}$, $V_{CC} = 24\text{V}$)

Characteristic	Symbol	Test Conditions	Min	Typ	Max	Unit	Test Fig
Regulated Voltage (Pin 5)	V_5		10.3	11.5	12.2	V	
DC Supply Current (Pin 5)	I_s	$V_{CC} = 9\text{V}$ $R_S = 0$	10	13	24	mA	
Quiescent Output Vtg (Pin 12)	V_{12}		4.5	5.1	5.8	V	—
AM Rejection*	AMR	$V_{in} = 2, 10, 100\text{mV}$ $f_o = 4.5\text{MHz}$, $\Delta f = \pm 25\text{KHz}$	40	55	—	dB	4
Input Limiting Threshold Voltage	V_i (lim)	$f_o = 4.5\text{MHz}$, $\Delta f = \pm 25\text{KHz}$	—	200	400	μVrms	4
Recovered Audio Output Voltage	V_o (AF)	$V_{in} = 10\text{mV}$ $f_o = 4.5\text{MHz}$, $\Delta f = \pm 25\text{KHz}$	0.5	0.90	—	Vrms	4
Output Distortion	THD	$V_{in} = 10\text{mVrms}$	—	0.9	2	%	4
Input Resistance (Pin 1 & 2)	R_i (IF)	$f = 4.5\text{MHz}$	—	17	—	$\text{K}\Omega$	
Input Capacitance (Pin 1 & 2)	C_i (IF)	$f = 4.5\text{MHz}$	—	4	—	pF	
Output Resistance (Pin 9 & GND)	R_o (IF)	$f = 4.5\text{MHz}$	—	3.25	—	$\text{K}\Omega$	
Output Capacitance (Pin 9 & GND)	C_o (IF)	$f = 4.5\text{MHz}$	—	7.5	—	pF	
Output Resistance,	Pin 7	R_o	—	7.5	—	$\text{K}\Omega$	
	Pin 8		—	250	—	Ω	
Volume Reduction Range		DC Volume Control = ∞	60	—	—	dB	4
Maximum Undesirable Signal (Note 1)			—	0.02	1	mVrms	4
Audio Amplifier Voltage Gain	A (AF)	$V_{in} = 0.2\text{Vrms}$, $f = 400\text{Hz}$	17.5	20.5	—	dB	5
Total Harmonic Distortion (Pin 12)	THD	$V_o = 2\text{Vrms}$, $f = 400\text{Hz}$	—	1.5	—	%	5
Output Voltage (Pin 12)		THD = 5%, $f = 400\text{Hz}$	2	3.4	—	Vrms	5
Input Resistance (Pin 14 & GND)	R_i (AF)	$f = 400\text{Hz}$	—	70	—	$\text{K}\Omega$	
Output Resistance (Pin 12 & GND)	R_o (AF)	$f = 400\text{Hz}$	—	270	—	Ω	

* 100% FM, 30% AM

Note 1. Undesirable signal is measured at pin 8 when volume control is set for minimum output.