



ACU50752
 CATV/TV/Cable Modem Upconverter
 MMIC

Data Sheet - Rev 2.0

FEATURES

- Integrated Monolithic Upconverter
- Compatible with all digital and analog modulation types
- 5 Volt Operation
- Low Power Consumption
- Low Noise Figure
- High Conversion Gain
- Low Distortion
- Excellent Oscillator Purity and Phase Noise
- Remote Shutdown Feature
- Small Size
- Low Cost
- High Reliability



PRODUCT DESCRIPTION

The ACU50752 is a Monolithic GaAs IC designed to perform the upconverter functions in a double conversion tuner: gain block, local oscillator and balanced mixer. The specifications meet the requirements of CATV, TV and Cable Modem applications. Offered in a modified 16-lead SOIC package and requiring only a single polarity 5 V supply (or 3.5 V, with slightly reduced performance), the IC is well suited for applications where small size, low cost, low auxiliary parts count and a no-compromise performance is important. It provides tuner manufacturers the opportunity to reduce cost by lowering the component count and decreasing the amount of labor-intensive production alignment steps, while significantly improving performance and reliability.

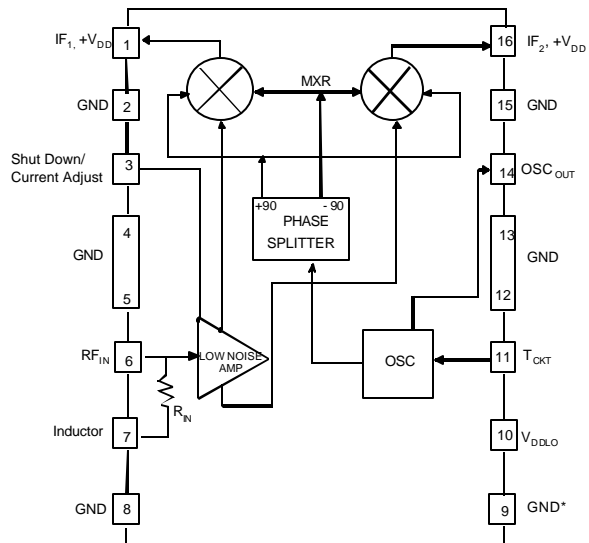

* Varactor return. Do not connect to common ground

Figure 1: Functional Block Diagram

Table 1: Pin Description

PIN	NAME	DESCRIPTION	PIN	NAME	DESCRIPTION
1	IF ₁ , V _{DDIF}	Balanced IFoutput and supply	9	VC _{RTN}	Varactor return
2	GND	Ground	10	V _{DDLO}	Oscillator supply
3	V _{BIAS}	Shut down/current adjust	11	Tank	Oscillator tank circuit
4	GND	Ground	12	GND	Ground
5	GND	Ground	13	GND	Ground
6	RF _N	RFInput	14	OSC _{OUT}	Oscillator output to Prescalar
7	I _{BIAS}	Current Bias	15	GND	Ground
8	GND	Ground	16	IF ₂ , V _{DDIF}	Balanced IF output and supply

ELECTRICAL CHARACTERISTICS

Table 2: Absolute Minimum and Maximum Ratings

PARAMETER	MIN	MAX	UNIT
$V_{DDIF}, V_{DDL0}, V_{OSC}$ (Pins 1,10,14 & 16)	0	9	VDC
V_{RF}/V_{TUNE} (Pins 6 & 11)	-	0	VDC
RF Input Voltage	-	+60	dBmV
Storage Temperature	- 55	+200	°C
Soldering Temperature	-	260	°C
Soldering Time	-	5	Sec.

Stresses in excess of the absolute ratings may cause permanent damage. Functional operation is not implied under these conditions. Exposure to absolute ratings for extended periods of time may adversely affect reliability.

Table 3: Operating Ranges

PARAMETER	MIN	TYP	MAX	UNIT	
Frequency	RF	50	-	860	MHz
	IF	900	-	1200	
	LO	950	-	2060	
V_{DDIF}	4.75	5	5.25	VDC	
V_{DDL0}	4.75	5	5.25	VDC	
Shutdown Voltage (Pin 3)	-	-2	-	V	
Tuning Voltage	1.5	-	27	V	
Operating Case Temperature	-40	-	+85	°C	

The device may be operated safely over these conditions; however, parametric performance is guaranteed only over the conditions defined in the electrical specifications.

Table 4: Electrical Specifications
 ($T_A = 25\text{ }^\circ\text{C}$; $V_{DDIF}, V_{DDLO} = +5\text{V}$; RF = 50 to 860 MHz; IF = 1170 MHz)

PARAMETER	MIN	TYP	MAX	UNIT
Conversion Gain ⁽¹⁾	5.0	8.0	-	dB
Gain Flatness ⁽¹⁾	-	1.0	-	dB
SSB Noise Figure ⁽¹⁾	-	6.5	8.0	dB
CSO ⁽²⁾	-	-60	-57	dBc
CTB ⁽²⁾	-	-60	-57	dBc
Cross Modulation ⁽³⁾	-	-62	-60	dBc
2-Tone 2nd Order Input IP ⁽⁴⁾	-	40	-	dBm
2-Tone 3rd Order Input IP ⁽⁴⁾	-	18	-	dBm
LO Phase Noise ⁽⁵⁾	-	-84	-81	dBc/Hz
LO Power to Prescaler	-10	-5	-	dBm
LO to RF Leakage	-	-22	-	dBm
LO to IF Leakage	-	-24	-	dBm
RF to IF Isolation	40	50	-	dB
Tuning Voltage ⁽¹⁾	1.0	-	22	V
I_{DDIF}	-	58	80	mA
I_{DDLO}	-	60	80	mA
Power Consumption	-	600	800	mW

Notes:

- (1) As measured in ANADIGICS test fixture
- (2) 128 Channels @ +7 dBmV
- (3) 128 Channels, 99 % Modulation @ 15 KHz
- (4) Two tones @ -15 dBm each
- (5) At 10 KHz offset

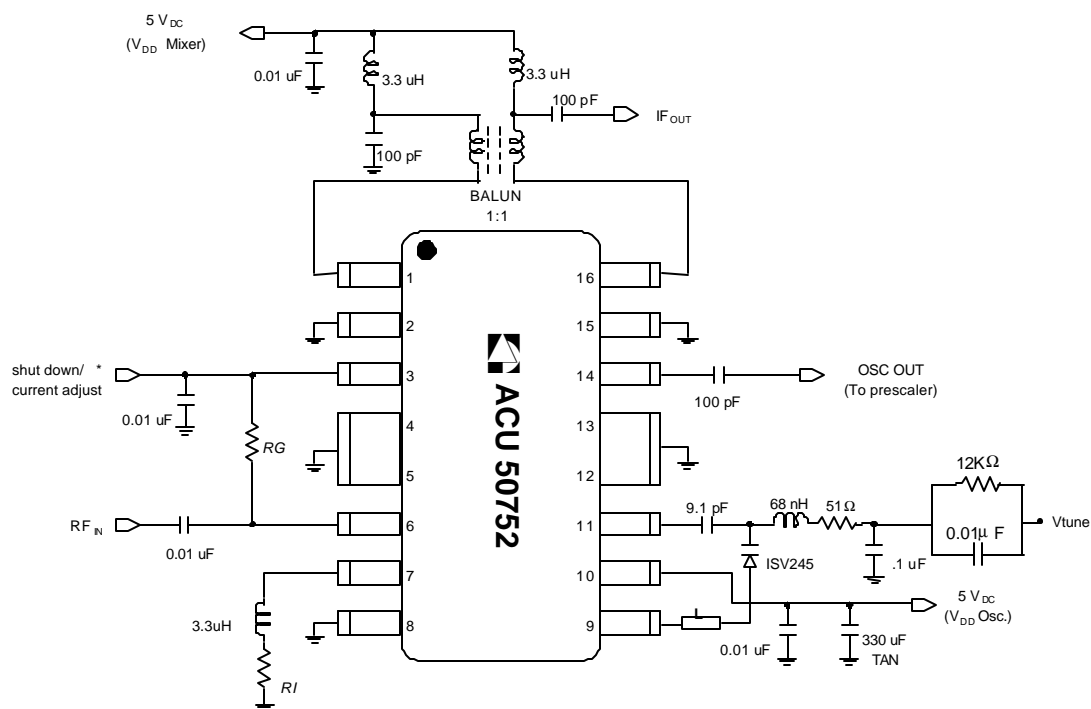

Figure 2: Test Circuit Schematic

Notes:

- L = Printed inductor (2~3 nH)
- RG = Gain control/impedance match resistor (240W for 8 dB gain)
- RI = Current adjust resistor (2.7 W for 60 mA mixer current)
- * = Apply -2 V DC for shutdown, 0 < VDC < 0.3 for 60 mA mixer current

ACU50752

PACKAGE OUTLINE

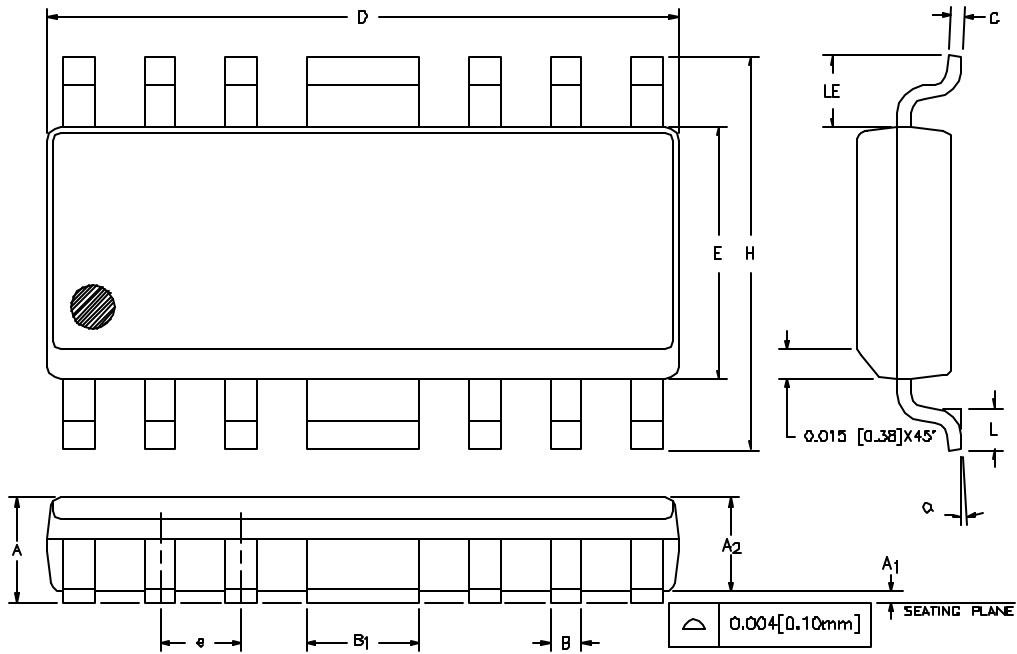

DIM.	INCHES		MILLIMETERS		NOTE
	MIN.	MAX.	MIN.	MAX.	
A	0.058	0.068	1.47	1.73	
A ₁	0.004	0.010	0.10	0.25	
A ₂	0.055	0.065	1.40	1.65	
B	0.013	0.020	0.33	0.50	
B ₁	0.062	0.070	1.58	1.78	
C	0.008	0.010	0.20	0.25	4
D	0.380	0.400	9.66	10.16	2
E	0.150	0.160	3.81	4.06	3
ø	0.050 BSC		1.27 BSC		
H	0.228	0.244	5.74	6.20	
L	0.016	0.040	0.41	1.02	
LE	0.030	—	0.76	—	
Q	Q'	B'	Q'	B'	

NOTES:

- 1 CONTROLLING DIMENSION: INCHES
- 2 DIMENSION "D" DOES NOT INCLUDE MOLD FLASH, PROTRUSIONS OR GATE BURRS, MOLD FLASH, PROTRUSIONS AND GATE BURRS SHALL NOT EXCEED 0.006 [0.15mm] PER SIDE.
- 3 DIMENSION "E" DOES NOT INCLUDE INTER-LEAD FLASH OR PROTRUSIONS INTER-LEAD FLASH AND PROTRUSIONS SHALL NOT EXCEED 0.010 [0.25mm] PER SIDE.
- 4 MAXIMUM LEAD TWIST/SKEW TO BE ±0.005 [0.13mm].
- 5 LEAD THICKNESS AFTER PLATING TO BE 0.013 [0.33mm] MAXIMUM.

Figure 3: S3 Package Outline - Modified 16 Pin SOIC

NOTES

ACU50752

ORDERING INFORMATION

ORDER NUMBER	TEMPERATURE RANGE	PACKAGE DESCRIPTION	COMPONENT PACKAGING
ACU50752S3CTR	-40°C to +85°C	Modified 16 Pin SOIC	Tape & Reel, 3500 pieces per reel
ACU50752S3C	-40°C to +85°C	Modified 16 Pin SOIC	Tube, 50 pieces per tube



ANADIGICS, Inc.

141 Mount Bethel Road
Warren, New Jersey 07059, U.S.A.
Tel: +1 (908) 668-5000
Fax: +1 (908) 668-5132

URL: <http://www.anadigics.com>

E-mail: Mktg@anadigics.com

IMPORTANT NOTICE

ANADIGICS, Inc. reserves the right to make changes to its products or to discontinue any product at any time without notice. The product specifications contained in Advanced Product Information sheets and Preliminary Data Sheets are subject to change prior to a product's formal introduction. Information in Data Sheets have been carefully checked and are assumed to be reliable; however, ANADIGICS assumes no responsibilities for inaccuracies. ANADIGICS strongly urges customers to verify that the information they are using is current before placing orders.

WARNING

ANADIGICS products are not intended for use in life support appliances, devices or systems. Use of an ANADIGICS product in any such application without written consent is prohibited.



LittleDiode supplies new, hard to find or obsolete electronic components and semiconductors all over the world.

With over two million different components listed you are sure to find the part you need.

Feel free to visit us today at our online store:

LittleDiode.com

Looking forward to providing you with the best possible service.