

### FEATURES

- Single-Chip Integrated  $\Sigma\Delta$  Digital Audio Stereo Codec
- Microsoft® and Windows® Sound System Compatible
- MPC Level-2+ Compliant Mixing
- 16 mA Bus Drive Capability
- Supports Two DMA Channels for Full Duplex Operation
- On-Chip Capture and Playback FIFOs
- Advanced Power-Down Modes
- Programmable Gain and Attenuation
- Sample Rates from 4.0 kHz to 50 kHz Derived from a Single Clock or Crystal Input
- 68-Lead PLCC, 100-Lead TQFP Packages
- Operation from +5 V Supplies
- Byte-Wide Parallel Interface to ISA and EISA Buses
- Pin Compatible with AD1848, AD1846, CS4248, CS4231

plete on-chip filtering, MPC Level-2 compliant analog mixing, programmable gain, attenuation and mute, a variable sample frequency generator, FIFOs, and supports advanced power-down modes. It provides a direct, byte-wide interface to both ISA ("AT") and EISA computer buses for simplified implementation on a computer motherboard or add-in card.

The AD1845 SoundPort Stereo Codec supports a DMA request/grant architecture for transferring data with the host computer bus. One or two DMA channels can be supported. Programmed I/O (PIO) mode is also supported for control register accesses and for applications lacking DMA control. Two input control lines support mixed direct and indirect addressing of thirty-seven internal control registers over this asynchronous interface. The AD1845 includes dual DMA count registers for full duplex operation enabling the AD1845 to capture data on one DMA channel and play back data on a separate channel. The FIFOs on the AD1845 reduce the risk of losing data when making DMA transfers over the ISA/EISA bus. The FIFOs buffer data transfers and allow for relaxed timing in acknowledging requests for capture and playback data.

### PRODUCT OVERVIEW

The Parallel Port AD1845 SoundPort Stereo Codec integrates key audio data conversion and control functions into a single integrated circuit. The AD1845 provides a complete, single chip computer audio solution for business audio and multimedia applications. The codec includes stereo audio converters, com-

*(Continued on Page 9)*

### FUNCTIONAL BLOCK DIAGRAM

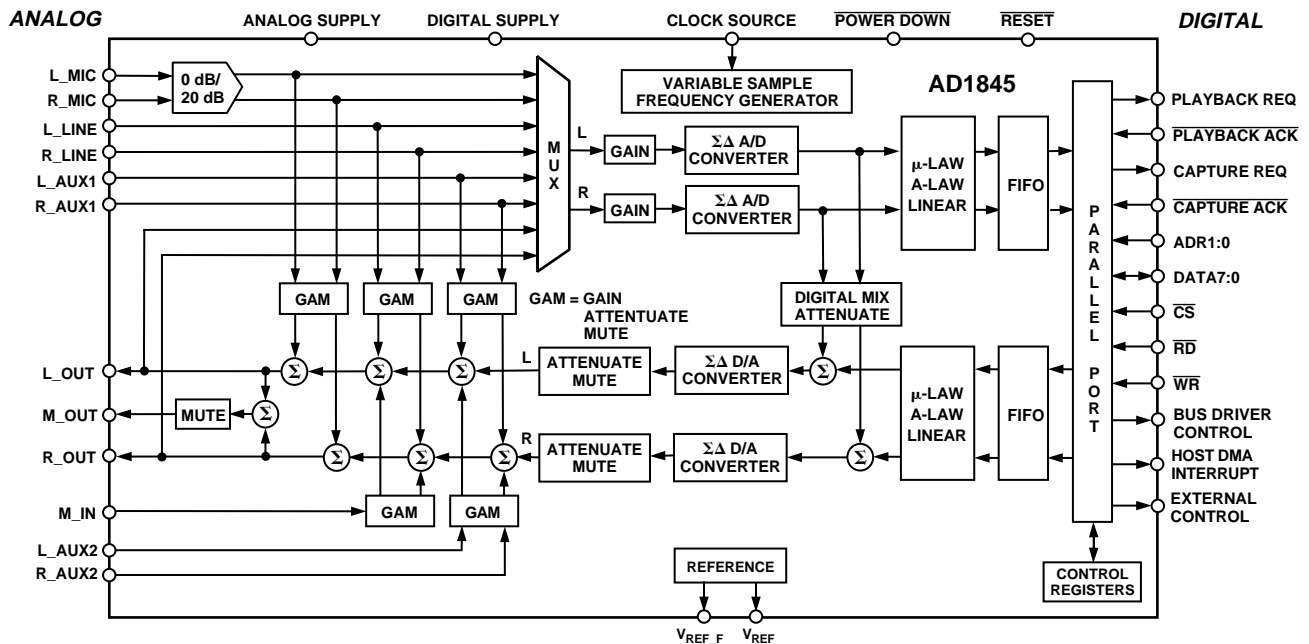

SoundPort is a registered trademark of Analog Devices, Inc.  
Microsoft and Windows are registered trademarks of Microsoft Corporation.

### REV. C

Information furnished by Analog Devices is believed to be accurate and reliable. However, no responsibility is assumed by Analog Devices for its use, nor for any infringements of patents or other rights of third parties which may result from its use. No license is granted by implication or otherwise under any patent or patent rights of Analog Devices.

# AD1845–SPECIFICATIONS

## STANDARD TEST CONDITIONS UNLESS OTHERWISE NOTED

Temperature	25	°C	<i>DAC Test Conditions</i>
Digital Supply ( $V_{DD}$ )	5.0	V	Calibrated
Analog Supply ( $V_{CC}$ )	5.0	V	0 dB Relative to Full Scale
Word Rate ( $F_S$ )	48	kHz	16-Bit Linear Mode
Input Signal	1008	Hz	10 k $\Omega$ Output Load
Analog Output Passband	20 Hz to 20 kHz		Mute Off, OL = 0
ADC FFT Size	2048		<i>ADC Test Conditions</i>
DAC FFT Size	8192		Calibrated
$V_{IH}$	5	V	0 dB Gain
$V_{IL}$	0	V	-1.0 dB Relative to Full Scale
			Line Input
			16-Bit Linear Mode

## ANALOG INPUT

	Min	Typ	Max	Units
Input Voltage (RMS Values Assume Sine Wave Input)				
Line		1		V rms
	2.55	2.83	3.35	V p-p
MIC with +20 dB Gain (MGE = 1)		0.1		V rms
	0.255	0.283	0.335	V p-p
MIC with 0 dB Gain (MGE = 0)		1		V rms
	2.55	2.83	3.35	V p-p
Input Impedance*	10	17		k $\Omega$
Input Capacitance		15		pF

## PROGRAMMABLE GAIN AMPLIFIER–ADC

	Min	Typ	Max	Units
Step Size (All Steps Tested)				
(0 dB to 22.5 dB)	0.7	1.5	1.9	dB
PGA Gain Range Span	21.5	22.5	23.5	dB

## AUXILIARY LINE, MONO, AND MICROPHONE INPUT ANALOG GAIN/AMPLIFIERS/ATTENUATORS

	Min	Typ	Max	Units
Step Size : AUX1, AUX2, LINE, MIC (All Steps Tested)				
(+12 dB to -30 dB)	1.25	1.5	1.75	dB
(-31.5 dB to -34.5 dB)	1	1.5	2.0	dB
Step Size: M_IN (All Steps Tested)				
(0 dB to -39 dB)	2.5	3.0	3.6	dB
(-42 dB to -45 dB)	2.2	3.0	3.85	dB
Input Gain/Attenuation Range: AUX1, AUX2, LINE, MIC	45.0	46.5	49.0	dB
Input Gain/Attenuation Range: M_IN	42	45	49	dB

## DIGITAL DECIMATION AND INTERPOLATION FILTERS\*

	Min	Max	Units
Passband	0	$0.4 \times F_S$	Hz
Passband Ripple		$\pm 0.1$	dB
Transition Band	$0.4 \times F_S$	$0.6 \times F_S$	Hz
Stopband	$0.6 \times F_S$	$\infty$	Hz
Stopband Rejection	74		dB
Group Delay		$15/F_S$	
Group Delay Variation Over Passband		0.0	$\mu$ s

\*Guaranteed, not tested.

**ANALOG-TO-DIGITAL CONVERTERS**

	Min	Typ	Max	Units
Resolution		16		Bits
Dynamic Range (-60 dB Input, THD+N Referenced to Full Scale, A-Weighted)	73	81		dB
THD+N (Referenced to Full Scale)			0.025	%
Signal-to-Intermodulation Distortion		-76	-72	dB
ADC Crosstalk*		85		dB
Line Inputs (Input L, Ground R, Read R; Input R, Ground L, Read L)		-90	-80	dB
Line to MIC (Input LINE, Ground and Select MIC, Read ADC)		-90	-80	dB
Line to AUX1		-90	-80	dB
Line to AUX2		-90	-80	dB
Gain Error (Full-Scale Span Relative to Nominal Input Voltage)	-18.5		+10	%
Interchannel Gain Mismatch (Difference of Gain Errors)			±0.9	dB
ADC Offset Error			10	mV

**DIGITAL-TO-ANALOG CONVERTERS**

	Min	Typ	Max	Units
Resolution		16		Bits
Dynamic Range (-60 dB Input, THD+N Referenced to Full Scale, A-Weighted)	74	82		dB
THD+N (Referenced to Full Scale)			0.032	%
Signal-to-Intermodulation Distortion		-78	-70	dB
Gain Error (Full-Scale Span Relative to Nominal Output Voltage)	-14.5	90	+10	%
Interchannel Gain Mismatch (Difference of Gain Errors)			±0.6	dB
DAC Crosstalk* (Input L, Zero R, Measure R_OUT; Input R, Zero L, Measure L_OUT)			-80	dB
Total Out-of-Band Energy (Measured from $0.6 \times F_S$ to 100 kHz)*			-50	dB
Audible Out-of-Band Energy (Measured from $0.6 \times F_S$ to 20 kHz)*			-70	dB

**DAC ATTENUATOR**

	Min	Typ	Max	Units
Step Size (0 dB to -22.5 dB)	1.3	1.5	1.7	dB
Step Size (-22.5 dB to -94.5 dB)*	1.0	1.5	2.0	dB
Output Attenuation Range Span*	93.5	94.5	95.5	dB

**ANALOG OUTPUT**

	Min	Typ	Max	Units
Full-Scale Output Voltage				
OL = 0	1.7	2.0	2.2	V p-p
OL = 1	2.4	2.83	3.11	V p-p
Output Impedance*			600	Ω
External Load Impedance	10			kΩ
Output Capacitance*			15	pF
External Load Capacitance			100	pF
$V_{REF}$	2.05	2.25	2.60	V
$V_{REF}$ Current Drive		100		μA
$V_{REF}$ Output Impedance		4		kΩ
Mute Attenuation of 0 dB Fundamental* (L_OUT, R_OUT, M_OUT)			-80	dB
Mute Click (Muted Output Minus Unmuted Midscale DAC Output)*			±5	mV

\*Guaranteed, not tested.

# AD1845

## SYSTEM SPECIFICATIONS

	Min	Typ	Max	Units
System Frequency Response Ripple (Line In to Line Out)*			1.0	dB
Differential Nonlinearity*			±1	LSB
Phase Linearity Deviation*			5	Degrees

## STATIC DIGITAL SPECIFICATIONS

	Min	Max	Units
High Level Input Voltage ( $V_{IH}$ )			
Digital Inputs	2.4		V
XTAL1I	2.4		V
Low Level Input Voltage ( $V_{IL}$ )		0.8	V
High Level Output Voltage ( $V_{OH}$ ) $I_{OH} = -2$ mA	2.4		V
Low Level Output Voltage ( $V_{OL}$ ) $I_{OL} = 2$ mA		0.4	V
Input Leakage Current	-10	10	μA
Output Leakage Current	-10	10	μA

## TIMING PARAMETERS (GUARANTEED OVER OPERATING TEMPERATURE RANGE, $V_{DD} = V_{CC} = 5.0$ V)

	Min	Max	Units
$\overline{WR}/\overline{RD}$ Strobe Width ( $t_{STW}$ )	100		ns
$\overline{WR}/\overline{RD}$ Rising to $\overline{WR}/\overline{RD}$ Falling ( $t_{BWND}$ )	80		ns
Write Data Setup to $\overline{WR}$ Rising ( $t_{WDSU}$ )	10		ns
$\overline{RD}$ Falling to Valid Read Data ( $t_{RDDV}$ )		40	ns
$\overline{CS}$ Setup to $\overline{WR}/\overline{RD}$ Falling ( $t_{CSSU}$ )	10		ns
$\overline{CS}$ Hold from $\overline{WR}/\overline{RD}$ Rising ( $t_{CSHD}$ )	0		ns
Adr Setup to $\overline{WR}/\overline{RD}$ Falling ( $t_{ADSU}$ )	10		ns
Adr Hold from $\overline{WR}/\overline{RD}$ Rising ( $t_{ADHD}$ )	10		ns
$\overline{DAK}$ Rising to $\overline{WR}/\overline{RD}$ Falling ( $t_{SUDK1}$ )	20		ns
$\overline{DAK}$ Falling to $\overline{WR}/\overline{RD}$ Rising ( $t_{SUDK2}$ )	0		ns
$\overline{DAK}$ Setup to $\overline{WR}/\overline{RD}$ Falling ( $t_{DKSU}$ )	10		ns
Data Hold from $\overline{RD}$ Rising ( $t_{DHD1}$ )		20	ns
Data Hold from $\overline{WR}$ Rising ( $t_{DHD2}$ )	15		ns
$\overline{DRQ}$ Hold from $\overline{WR}/\overline{RD}$ Falling ( $t_{DRHD}$ )		25	ns
$\overline{DAK}$ Hold from $\overline{WR}$ Rising ( $t_{DKHDa}$ )	10		ns
$\overline{DAK}$ Hold from $\overline{RD}$ Rising ( $t_{DKHDb}$ )	10		ns
$\overline{DBEN}/\overline{DBDIR}$ Delay from $\overline{WR}/\overline{RD}$ Falling ( $t_{DBDL}$ )		30	ns
$\overline{PWRDWN}$ and $\overline{RESET}$ Low Pulsewidth	300		ns

\*Guaranteed, not tested.

**POWER SUPPLY**

	Min	Typ	Max	Units
Power Supply Range–Digital and Analog	4.75		5.25	V
Power Supply Current			130	mA
Analog Supply Current			45	mA
Digital Supply Current			85	mA
Power Dissipation (Current × Nominal Supplies)			650	mW
Power-Down Supply Current			2	mA
Reset Supply Current		2		mA
Total Power-Down Supply Current			30	mA
Standby Supply Current		36		mA
Mixer Power-Down Supply Current			70	mA
Mixer Only Supply Current		52		mA
ADC Power-Down Supply Current			80	mA
DAC Power-Down Supply Current			85	mA
Power Supply Rejection (100 mV p-p Signal @ 1 kHz)* (At Both Analog and Digital Supply Pins, both ADCs and DACs)	40			dB

**CLOCK SPECIFICATIONS\***

	Min	Max	Units
Input Clock Frequency		33	MHz
Recommended Clock Duty Cycle	10	90	%
Power Up Initialization Time		512	ms

\*Guaranteed, not tested.

Specifications subject to change without notice.

**ORDERING GUIDE**

Model	Temperature Range	Package Description	Package Option <sup>1</sup>
AD1845JP	0°C to +70°C	68-Lead PLCC	P-68A
AD1845JP-REEL <sup>2</sup>	0°C to +70°C	68-Lead PLCC	P-68A
AD1845JST	0°C to +70°C	100-Lead TQFP	ST-100

## NOTES

<sup>1</sup>P = Plastic Leaded Chip Carrier; ST = Thin Quad Flatpack.<sup>2</sup>13" Reel, multiples of 250 pcs.**ENVIRONMENTAL CONDITIONS**

## Ambient Temperature Rating:

$$T_{AMB} = T_{CASE} - (PD \times \theta_{CA})$$

 $T_{CASE}$  = Case Temperature in °C

 $PD$  = Power Dissipation in W

 $\theta_{CA}$  = Thermal Resistance (Case-to-Ambient)

 $\theta_{JA}$  = Thermal Resistance (Junction-to-Ambient)

 $\theta_{JC}$  = Thermal Resistance (Junction-to-Case)

Package	$\theta_{JA}$	$\theta_{JC}$	$\theta_{CA}$
PLCC	38°C/W	8°C/W	30°C/W
TQFP	44°C/W	8°C/W	93°C/W

**CAUTION**

ESD (electrostatic discharge) sensitive device. Electrostatic charges as high as 4000 V readily accumulate on the human body and test equipment and can discharge without detection. Although the AD1845 features proprietary ESD protection circuitry, permanent damage may occur on devices subjected to high energy electrostatic discharges. Therefore, proper ESD precautions are recommended to avoid performance degradation or loss of functionality.

**ABSOLUTE MAXIMUM RATINGS\***

	Min	Max	Units
Power Supplies			
Digital ( $V_{DD}$ )	-0.3	6.0	V
Analog ( $V_{CC}$ )	-0.3	6.0	V
Input Current (Except Supply Pins)		±10.0	mA
Analog Input Voltage (Signal Pins)	-0.3	$V_{CC} + 0.3$	V
Digital Input Voltage (Signal Pins)	-0.3	$V_{DD} + 0.3$	V
Ambient Temperature (Operating)	0	+70	°C
Storage Temperature	-65	+150	°C

\*Stresses greater than those listed under Absolute Maximum Ratings may cause permanent damage to the device. This is a stress rating only; functional operation of the device at these or any other conditions above those indicated in the operational section of this specification is not implied. Exposure to absolute maximum rating conditions for extended periods may affect device reliability.



# AD1845

## PIN DESIGNATIONS

68-Lead PLCC

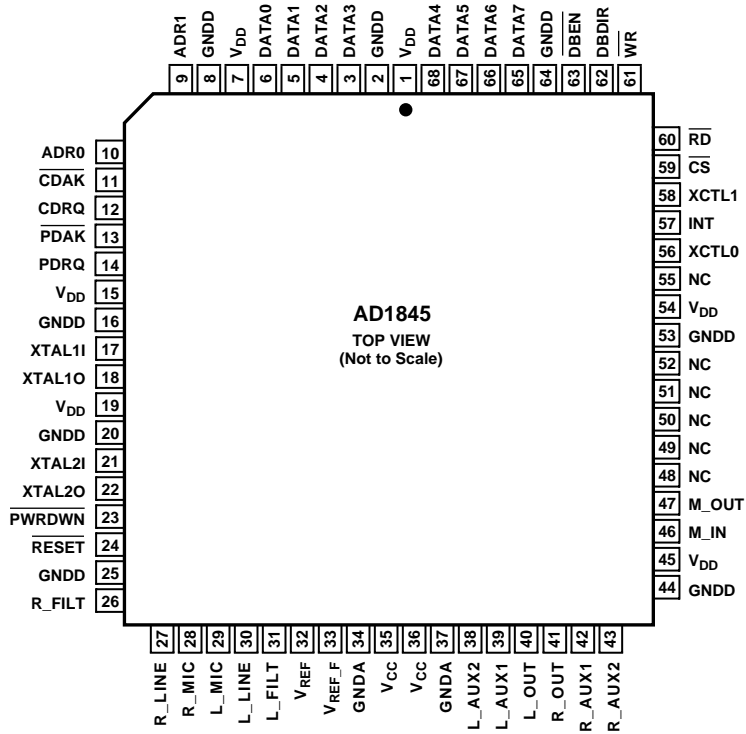

NC = NO CONNECT

100-Lead TQFP

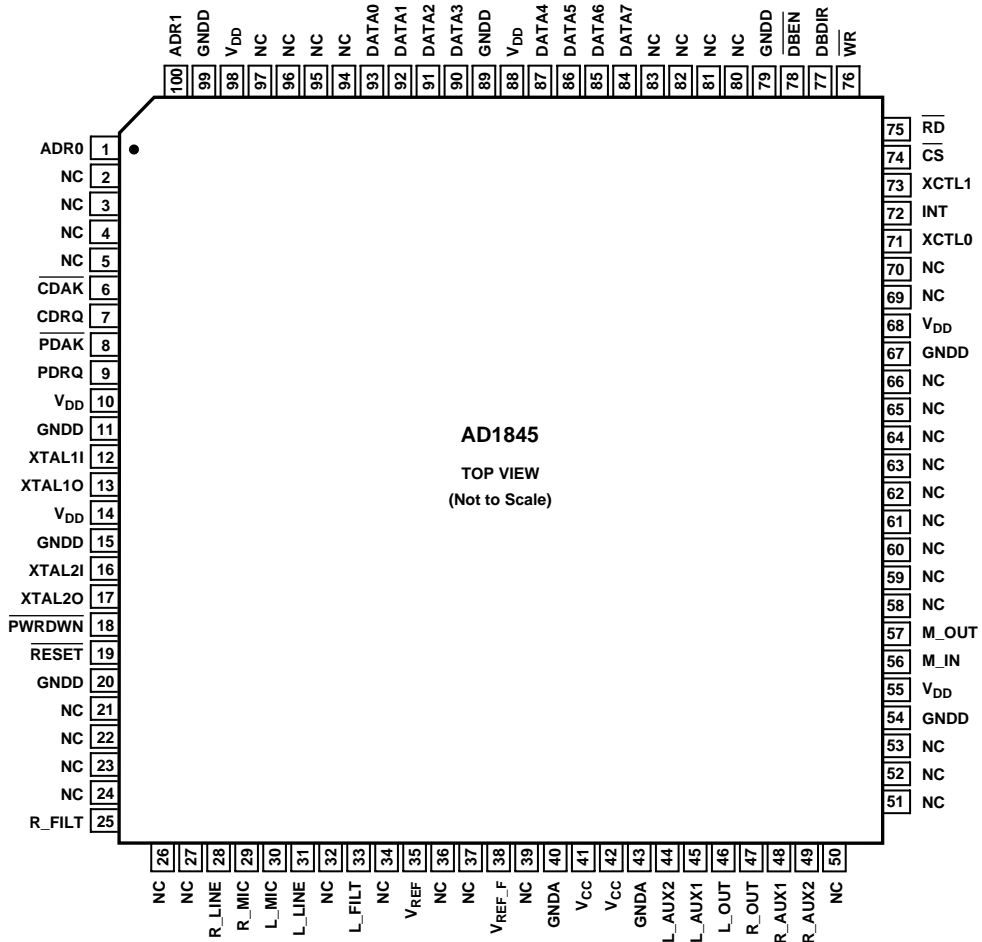

NC = NO CONNECT

## PIN FUNCTION DESCRIPTIONS

## Parallel Interface

Pin Name	PLCC	TQFP	I/O	Description
CDRQ	12	7	O	Capture Data Request. The assertion of this signal HI indicates that the codec has a captured audio sample from the ADC ready for transfer. This signal will remain asserted until the internal capture FIFO is empty.
$\overline{\text{CDAK}}$	11	6	I	Capture Data Acknowledge. The assertion of this active LO signal indicates that the $\overline{\text{RD}}$ cycle occurring is a DMA read from the capture buffer.
PDRQ	14	9	O	Playback Data Request. The assertion of this signal HI indicates that the codec is ready for more DAC playback data. The signal will remain asserted until the internal playback FIFO is full.
$\overline{\text{PDAK}}$	13	8	I	Playback Data Acknowledge. The assertion of this active LO signal indicates that the $\overline{\text{WR}}$ cycle occurring is a DMA write to the playback buffer.
ADR1:0	9 & 10	100 & 1	I	Codec Addresses. These address pins are asserted by the codec interface logic during a control register/PIO access. The state of these address lines determine which direct register is accessed.
$\overline{\text{RD}}$	60	75	I	Read Command Strobe. This active LO signal defines a read cycle from the codec. The cycle may be a read from the control/PIO registers, or the cycles could be a read from the codec's DMA sample registers.
$\overline{\text{WR}}$	61	76	I	Write Command Strobe. This active LO signal indicates a write cycle to the codec. The cycle may be a write to the control/PIO registers, or the cycle could be a write to the codec's DMA sample registers.
$\overline{\text{CS}}$	59	74	I	AD1845 Chip Select. The codec will not respond to any control/PIO cycle accesses unless this active LO signal is LO. This signal is ignored during DMA transfers.
DATA7:0	3-6 & 65-68	84-87 & 90-93	I/O	Data Bus. These pins transfer data and control information between the codec and the host.
$\overline{\text{DBEN}}$	63	78	O	Data Bus Enable. This pin enables the external bus drivers. This signal is normally HI. For control register/PIO cycles, $\overline{\text{DBEN}} = (\overline{\text{WR}} \text{ or } \overline{\text{RD}}) \text{ and } \overline{\text{CS}}$ For DMA cycles, $\overline{\text{DBEN}} = (\overline{\text{WR}} \text{ or } \overline{\text{RD}}) \text{ and } (\overline{\text{PDAK}} \text{ or } \overline{\text{CDAK}})$ .
DBDIR	62	77	O	Data Bus Direction. This pin controls the direction of the data bus transceiver. HI enables writes from the host bus to the AD1845; LO enables reads from the AD1845 to the host bus. This signal is normally HI. For control register/PIO cycles, $\text{DBDIR} = \overline{\text{RD}} \text{ and } \overline{\text{CS}}$ For DMA cycles, $\text{DBDIR} = \overline{\text{RD}} \text{ and } (\overline{\text{PDAK}} \text{ or } \overline{\text{CDAK}})$ .

# AD1845

## Analog Signals

Pin Name	PLCC	TQFP	I/O	Description
L_LINE	30	31	I	Left Line Input.
R_LINE	27	28	I	Right Line Input.
L_MIC	29	30	I	Left Microphone Input. This signal can be either line level or -20 dB from line level (using the on-chip 20 dB gain block).
R_MIC	28	29	I	Right Microphone Input. This signal can be either line level or -20 dB from line level (using the on-chip 20 dB gain block).
L_AUX1	39	45	I	Left Auxiliary #1 Line Input.
R_AUX1	42	48	I	Right Auxiliary #1 Line Input.
L_AUX2	38	44	I	Left Auxiliary #2 Line Input.
R_AUX2	43	49	I	Right Auxiliary #2 Line Input.
L_OUT	40	46	O	Left Line Output.
R_OUT	41	47	O	Right Line Output.
M_IN	46	56	I	Mono Input.
M_OUT	47	57	O	Mono Output.

## Miscellaneous

Pin Name	PLCC	TQFP	I/O	Description
XTAL1I	17	12	I	24.576 MHz Crystal #1 Input.
XTAL1O	18	13	O	24.576 MHz Crystal #1 Output.
XTAL2I	21	16		Not used on the AD1845.
XTAL2O	22	17		Not used on the AD1845.
$\overline{\text{PWRDWN}}$	23	18	I	Power Down Signal. Active LO places the AD1845 in its lowest power consumption mode. All sections of the AD1845, including the digital interface, are shut down and consume minimal power.
INT	57	72	O	Host Interrupt Pin. A host interrupt is generated to notify the host that a specified event has occurred.
XCTL1:0	58 & 56	73 & 71	O	External Control. These signals reflect the current status of register bits inside the AD1845. They can be used for signaling or to control external logic.
$\overline{\text{RESET}}$	24	19	I	Reset. Active LO resets all digital registers and filters, and resets all analog filters. Active LO places the AD1845 in the lowest power consumption mode. XTAL1 is required to be running during the minimum low pulsewidth of the reset signal.
V <sub>REF</sub>	32	35	O	Voltage Reference. Nominal 2.25 volt reference available for dc-coupling and level-shifting. V <sub>REF</sub> should not be used to sink or source current.
V <sub>REF_F</sub>	33	38	I	Voltage Reference Filter. Voltage reference filter point for external bypassing only.
L_FILT	31	33	I	Left Channel Filter. This pin requires a 1.0 $\mu\text{F}$ capacitor to analog ground for proper operation.
R_FILT	26	25	I	Right Channel Filter. This pin requires a 1.0 $\mu\text{F}$ capacitor to analog ground for proper operation.
NC	48-52, 55	2-5, 21-24 26, 27, 32, 34, 36, 37, 39, 50-53, 58-66, 69, 70, 80-83, 94-97		No Connect.

## Power Supplies

Pin Name	PLCC	TQFP	I/O	Description
V <sub>CC</sub>	35 & 36	41 & 42	I	Analog Supply Voltage (+5 V).
GNDA	34 & 37	40 & 43	I	Analog Ground.
V <sub>DD</sub>	1, 7, 15, 19, 45, 54	10, 14, 55, 68, 88, 98	I	Digital Supply Voltage (+5 V).
GNDD	2, 8, 16, 20, 25, 44, 53, 64	11, 15, 20, 54, 67, 79, 89, 99	I	Digital Ground.

(Continued from page 1)

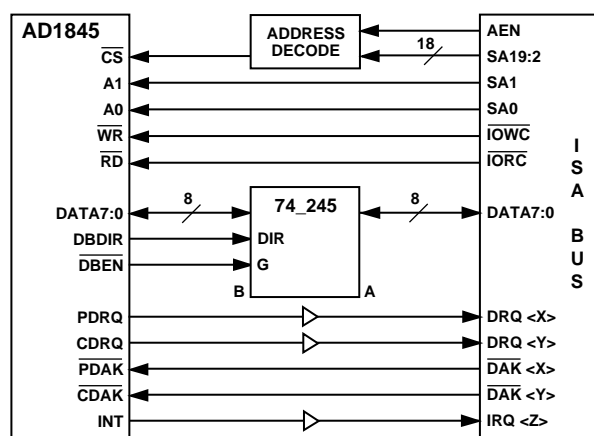

Figure 1. Interface to ISA Bus

External circuit requirements are limited to a minimal number of low cost support components. Anti-imaging DAC output filters are incorporated on-chip. Dynamic range exceeds 80 dB over the 20 kHz audio band. Sample rates from 4 kHz to 50 kHz are supported from a single external crystal or clock source.

The AD1845 has built-in 8/16 mA (user selectable) bus drivers. If 24 mA drive capability is required, the AD1845 generates enable and direction controls for IC bus buffers such as the 74\_245.

The codec includes a stereo pair of  $\Sigma\Delta$  analog-to-digital converters and a stereo pair of  $\Sigma\Delta$  digital-to-analog converters. The AD1845 mixer surpasses MPC Level-2 recommendations. Inputs to the ADC can be selected from four stereo pairs of analog signals: line (LINE), microphone (MIC), auxiliary line #1 (AUX1), and post-mixed DAC output. A software-controlled programmable gain stage allows independent gain for each channel going into the ADC. In addition, the analog mixer allows the mono input (M\_IN), MIC, AUX1, LINE and auxiliary line #2 (AUX2) signals to be mixed with the DACs' output. The ADCs' output can be digitally mixed with the DACs' input.

The pair of 16-bit outputs from the ADCs is available over a byte-wide bidirectional interface that also supports 16-bit digital input to the DACs and control information. The AD1845 can accept and generate 16-bit twos complement PCM linear digital data in both little endian or big endian byte ordering, 8-bit

unsigned magnitude PCM linear data, and 8-bit  $\mu$ -law or A-law companded digital data.

The  $\Sigma\Delta$  DACs are preceded by a digital interpolation filter. An attenuator provides independent user volume control over each DAC channel. Nyquist images and shaped quantized noise are removed from the DACs' analog stereo output by on-chip switched-capacitor and continuous-time filters.

The AD1845 supports multiple low power and power-down modes to support notebook and portable computing multimedia applications. The ADC, DAC, and mixer paths can be suspended independently allowing the AD1845 to be used for capture-only or playback-only, lessening power consumption and extending battery life.

The AD1845 includes a variable sample frequency generator, that allows the codec to instantaneously change sample rates with a resolution of 1 Hz without "clicks" and "pops." Additionally,  $\Sigma\Delta$  quantization noise is kept out of the 20 kHz audio band regardless of the chosen sample rate. The codec uses the variable sample frequency generator to derive all internal clocks from a single external crystal or clock source.

#### Expanded Mode (MODE2)

MODE1 is the initial state of the AD1845. In this state the AD1845 appears as an AD1848 compatible device. To access the expanded modes of operation on the AD1845, the MODE2 bit should be set in the Miscellaneous Information Control Register. When this bit is set to one, 16 additional indirect registers can be addressed allowing the user to access the AD1845's expanded features. The AD1845 can return to MODE1 operation by clearing the MODE2 bit. In both MODE1 and MODE2, the capture and playback FIFOs are active to prevent data loss.

The additional MODE2 functions are:

1. Full-Duplex DMA support.
2. MIC input mixer, mute and volume control.
3. Mono output with mute control.
4. Mono input with mixer volume control.
5. Software controlled advanced power-down modes.
6. Programmable sample rates from 4 kHz to 50 kHz in 1 Hz increments.

# AD1845

## FUNCTIONAL DESCRIPTION

This section overviews the functionality of the AD1845 and is intended as a general introduction to the capabilities of the device. As much as possible, detailed reference information has been placed in “Control Registers” and other sections. The user is not expected to refer repeatedly to this section.

### Analog Inputs

The AD1845 SoundPort Stereo Codec accepts stereo line-level and microphone-level inputs. The LINE, MIC, AUX1, and post-mixed DAC output are available to the ADC multiplexer. The DAC output can be mixed with LINE, MIC, AUX1, AUX2 and M\_IN. Each channel of the MIC inputs can be amplified by +20 dB to compensate for the difference between line levels and typical condenser microphone levels.

### Analog Mixing

The M\_IN mono input signal, MIC, LINE, AUX1 and AUX2 analog stereo signals can be mixed in the analog domain with the DAC output. Each channel of each AUX, LINE and MIC analog input can be independently gained/attenuated from +12 dB to -34.5 dB in 1.5 dB steps or completely muted. M\_IN can be attenuated from 0 dB to -45 dB in 3 dB steps or muted. The post-mixed DAC outputs are available on L\_OUT and R\_OUT and also to the ADC input multiplexer.

Even if the AD1845 is not playing back data from its DACs, the analog mix function can still be active.

### Analog-to-Digital Datapath

The PGA following the input multiplexer allows independent selectable gains for each channel from 0 dB to 22.5 dB in +1.5 dB steps. The codec can operate either in a global stereo mode or in a global mono mode with left-channel inputs appearing at both channel outputs.

The AD1845  $\Sigma\Delta$  ADCs incorporate a fourth-order modulator. A single pole of passive filtering is all that is required for anti-aliasing the analog input because of the ADC's high over sampling ratio. The ADCs include linear-phase digital decimation filters that low-pass filter the input to  $0.4 \times F_S$ . (“ $F_S$ ” is the word rate or “sampling frequency.”) ADC input over range conditions are reported on status bits in the Test and Initialization Register.

### Digital-to-Analog Datapath

The  $\Sigma\Delta$  DACs are preceded by a programmable attenuator and a low-pass digital interpolation filter. The anti-imaging interpolation filter over samples and digitally filters the higher frequency images. The attenuator allows independent control of each DAC channel from 0 dB to -94.5 dB in -1.5 dB steps plus full mute. The DACs'  $\Sigma\Delta$  noise shapers also over sample and convert the signal to a single-bit stream. The DAC outputs are then filtered in the analog domain by a combination of switched-capacitor and continuous-time filters. They remove the very high frequency components of the DAC bit stream output. No external components are required.

Changes in DAC output attenuation take effect only on zero crossings, eliminating “zipper” noise on playback. Each channel has its own independent zero-crossing detector and attenuator change control circuitry. A timer guarantees that requested volume changes will occur even in the absence of a zero crossing. The time-out period is 8 milliseconds at a 48 kHz sampling rate and 48 milliseconds at an 8 kHz sampling rate. (Timeout [ms]  $\approx 384 \div F_S$  [kHz].)

### Digital Mixing

Stereo digital output from the ADCs can be digitally mixed with the input to the DACs. Digital output from the ADCs going out of the data port is unaffected by the digital mix. Along the digital mix datapath, the 16-bit linear output from the ADCs is attenuated by an amount specified with control bits. Both channels of the digital mix datapath are attenuated by the same amount. (Note that internally the AD1845 always works with 16-bit PCM linear data, digital mixing included; format conversions take place at the input and output.)

Sixty-four steps of -1.5 dB attenuation are supported to -94.5 dB. The digital mix datapath can also be completely muted. Note that the level of the mixed signal is also a function of the input PGA settings, since they affect the ADCs' output.

The attenuated digital mix data is digitally summed with the DAC input data prior to the DACs' datapath attenuators. The digital sum of digital mix data and DAC input data is clipped at plus or minus full scale and does not wrap around. Because both stereo signals are mixed before the output attenuators, mix data is attenuated a second time by the DACs' datapath attenuators.

In case the AD1845 is capturing data, but ADC output data is not removed in time (“ADC overrun”), the last sample captured before overrun will be used for the digital mix. In case the AD1845 is playing back data, but input digital DAC data fails to arrive in time (“DAC underrun”), a midscale zero will be added to the digital mix data when the DACZ control bit is set to 0; otherwise, the DAC will output the previous valid sample in an underrun condition.

### Analog Outputs

Stereo and mono line-level outputs are available at external pins. Each channel of this output can be independently muted. When muted, the outputs will settle to a dc value near  $V_{REF}$ , the midscale reference voltage. The output is selectable for 2.0 V peak-to-peak or 2.8 V peak-to-peak. When selecting the LINE output as an input to the ADC, the ADC automatically compensates for the output level selection.

### Digital Data Types

The AD1845 supports five global data types: 16-bit twos complement linear PCM (little endian and big endian byte ordering), 8-bit unsigned linear PCM, companded  $\mu$ -law, and 8-bit companded A-law, as specified by control register bits. Data in all formats is always transferred MSB first. All data formats that are less than 16 bits are MSB-aligned to ensure the use of full system resolution.

The 16-bit PCM data format is capable of representing 96 dB of dynamic range. Eight-bit PCM can represent 48 dB of dynamic range. Companded  $\mu$ -law and A-law data formats use nonlinear coding with less precision for large amplitude signals. The loss of precision is compensated for by an increase in dynamic range to 64 dB and 72 dB, respectively.

On input, 8-bit companded data is expanded to an internal linear representation, according to whether  $\mu$ -law or A-law was specified in the codec's internal registers. Note that when  $\mu$ -law compressed data is expanded to a linear format, it requires 14 bits. A-law data expanded requires 13 bits.

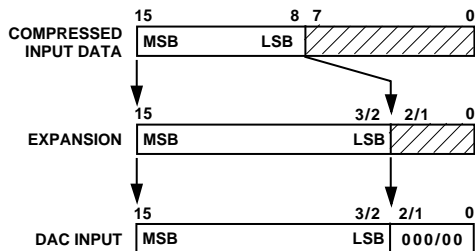

Figure 2.  $\mu$ -Law or A-Law Expansion

When 8-bit companding is specified, the ADCs' linear output is compressed to the format specified.

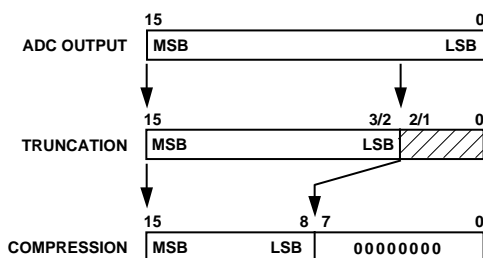

Figure 3.  $\mu$ -Law or A-Law Compression

Note that all format conversions take place at input or output. Internally, the AD1845 always uses 16-bit linear PCM representations to maintain maximum precision.

### Timer Registers

The timer registers are provided for system level synchronization, and for periodic interrupt generation. The 16-bit timer time base is determined by the frequency of the connected input clock source.

The timer is enabled by setting the Timer Enable bit, TE, in the Alternate Feature Enable register. To set the timer, load the Upper and Lower Timer Bits Registers. The timer value will then be loaded into an internal count register with a value of approximately 10  $\mu$ s (the exact timer value is listed in the register descriptions). The internal count register will decrement until it reaches zero, then the Timer Interrupt bit, TI, is set and an interrupt will be sent to the host. The next timer clock will load the internal count register with the value of the Timer Register, and the timer will be reinitialized. To clear the interrupt, write to the Status Register or write a "0" to TI.

### Interrupts

The AD1845 supports interrupt conditions generated by DMA playback count expiration, DMA capture count expiration, or timer expiration. The INT bit will remain set, HI, until a write has been completed to the Status Register or by clearing the TI, CI, or PI bit (depending on the existing condition) in the Capture Playback Timer Register. The IEN bit of the Pin Control Register determines whether the interrupt pin responds to an interrupt condition and reflects the interrupt state on the INT status bit.

### Power Supplies and Voltage Reference

The AD1845 operates from a +5 V power supply. Independent analog and digital supplies are recommended for optimal performance though excellent results can be obtained in single-supply systems. A voltage reference is included on the codec and its 2.25 V buffered output is available on an external pin ( $V_{REF}$ ). The reference output can be used for biasing op amps used in dc coupling. The internal reference is externally bypassed to analog ground at the  $V_{REF\_F}$  pin.

### Clocks and Sample Rates

The AD1845 operates from a single external crystal or clock source. From a single input, a wide range of sample rates can be generated. The AD1845 default frequency source is a 24.576 MHz input. The AD1845 can also be driven from a 14.31818 MHz (OSC), 24 MHz, 25 MHz or 33 MHz input frequency source. In MODE1, the input drives the internal variable sample frequency generator to derive the following AD1848 compatible sample rates: 5.5125, 6.615, 8, 9.6, 11.025, 16, 18.9, 22.05, 27.42857, 32, 33.075, 37.8, 44.1, 48 kHz. In MODE2, the AD1845 can be programmed to generate any sample frequency between 4 kHz and 50 kHz with 1 Hz resolution. Note that it is no longer required to enter Mode Change Enable (MCE) to change the sample rate. This feature allows the user to change the AD1845's sample rate "on the fly."

### CONTROL REGISTERS

#### Control Register Architecture

The AD1845 SoundPort Stereo Codec accepts both data and control information through its byte-wide parallel port. Indirect addressing minimizes the number of external pins required to access all 37 of its byte-wide internal registers. Only two external address pins, ADR1:0, are required to accomplish all data and control transfers. These pins select one of five direct registers. (ADR1:0 = 3 addresses two registers, depending on whether the transfer is for a playback or capture.)

ADR1:0	Register Name
0	Index Address Register
1	Indexed Data Register
2	Status Register
3	PIO Data Register

Figure 4. Direct Register Map

# AD1845

A write to or a read from the Indexed Data Register will access the Indirect Register which is indexed by the value most recently written to the Index Address Register. The Status Register and the PIO Data Register are always accessible directly, without indexing. The 32 Indirect Register indexes are shown in Figure 5:

<b>Index</b>	<b>Register Name</b>	<b>Reset/Default State</b>	
0	Left Input Control	000x	0000
1	Right Input Control	000x	0000
2	Left Aux #1 Input Control	1xx0	1000
3	Right Aux #1 Input Control	1xx0	1000
4	Left Aux #2 Input Control	1xx0	1000
5	Right Aux #2 Input Control	1xx0	1000
6	Left Output Control	1x00	0000
7	Right Output Control	1x00	0000
8	Clock and Data Format	0000	0000
9	Interface Configuration	00xx	1000
10	Pin Control	00xx	xx00
11	Test and Initialization	0000	0000
12	Miscellaneous Information	10x0	1010
13	Digital Mix/Attenuation	0000	00x0
14	Upper Base Count	0000	0000
15	Lower Base Count	0000	0000
16	Alternate Feature Enable/Left MIC Input Control	0001	0001
17	MIC Mix Enable/Right MIC Input Control	0001	000x
18	Left Line Gain, Attenuate, Mute, Mix	1xx0	1000
19	Right Line Gain, Attenuate, Mute, Mix	1xx0	1000
20	Lower Timer	0000	0000
21	Upper Timer	0000	0000
22	Upper Frequency Select	0001	1111
23	Lower Frequency Select	0100	0000
24	Capture Playback Timer	x000	0000
25	Revision ID	100x	x000
26	Mono Control	00xx	0011
27	Power-Down Control	000x	0xxx
28	Capture Data Format Control	0000	xxxx
29	Crystal Clock Select/Total Power-Down	000x	xxx0
30	Capture Upper Base Count	0000	0000
31	Capture Lower Base Count	0000	0000

"x" indicates reserved bit, always write "0s" to these bits.

*Figure 5. Indirect Register Map and Reset/Default States*

A detailed map of all direct and indirect register contents is summarized for reference as follows:

**Direct Registers**

ADRI:0	Data 7	Data 6	Data 5	Data 4	Data 3	Data 2	Data 1	Data 0
0	INIT	MCE	TRD	IXA4	IXA3	IXA2	IXA1	IXA0
1	IXD7	IXD6	IXD5	IXD4	IXD3	IXD2	IXD1	IXD0
2	CU/L	CL/R	CRDY	SOUR	PU/L	PL/R	PRDY	INT
3	CD7	CD6	CD5	CD4	CD3	CD2	CD1	CD0
3	PD7	PD6	PD5	PD4	PD3	PD2	PD1	PD0

**Indirect Registers**

IXA3:0	Data 7	Data 6	Data 5	Data 4	Data 3	Data 2	Data 1	Data 0
0	LSS1	LSS0	LMGE	res	LIG3	LIG2	LIG1	LIG0
1	RSS1	RSS0	RMGE	res	RIG3	RIG2	RIG1	RIG0
2	LMX1	res	res	LX1A4	LX1A3	LX1A2	LX1A1	LX1A0
3	RMX1	res	res	RX1A4	RX1A3	RX1A2	RX1A1	RX1A0
4	LMX2	res	res	LX2A4	LX2A3	LX2A2	LX1A1	LX2A0
5	RMX2	res	res	RX2A4	RX2A3	RX2A2	RX2A1	RX2A0
6	LDM	res	LDA5	LDA4	LDA3	LDA2	LDA1	LDA0
7	RDM	res	RDA5	RDA4	RDA3	RDA2	RDA1	RDA0
8	FMT1	FMT0	C/L	S/M	CFS2	CFS1	CFS0	CSS
9	CPIO	PPIO	res	res	ACAL	SDC	CEN	PEN
10	XCTL1	XCTL0	res	res	res	res	IEN	INITD
11	COR	PUR	ACI	DRS	ORR1	ORR0	ORL1	ORL0
12	MID	MODE2	BUF8	res	ID3	ID2	ID1	ID0
13	DMA5	DMA4	DMA3	DMA2	DMA1	DMA0	res	DME
14	UB7	UB6	UB5	UB4	UB3	UB2	UB1	UB0
15	LB7	LB6	LB5	LB4	LB3	LB2	LB1	LB0
<b>Expanded Mode (Requires MODE2=1)</b>								
16	OL	TE	LMG4	LMG3	LMG2	LMG1	LMG0	DACZ
17	LMME	RMME	RMG4	RMG3	RMG2	RMG1	RMG0	res
18	LLM	res	res	LLG4	LLG3	LLG2	LLG1	LLG0
19	RLM	res	res	RLG4	RLG3	RLG2	RLG1	RLG0
20	TL7	TL6	TL5	TL4	TL3	TL2	TL1	TL0
21	TU7	TU6	TU5	TU4	TU3	TU2	TU1	TU0
22	FU7	FU6	FU5	FU4	FU3	FU2	FU1	FU0
23	FL7	FL6	FL5	FL4	FL3	FL2	FL1	FL0
24	res	TI	CI	PI	CU	CO	PO	PU
25	V2	V1	V0	res	res	CID2	CID1	CID0
26	MIM	MOM	res	res	MIA3	MIA2	MIA1	MIA0
27	ADCPWD	DACPWD	MIXPWD	res	FREN	res	res	res
28	CFMT1	CFMT0	CC/L	CS/M	res	res	res	res
29	XFS2	XFS1	XFS0	res	res	res	res	TOTPWD
30	CUB7	CUB6	CUB5	CUB4	CUB3	CUB2	CUB1	CUB0
31	CLB7	CLB6	CLB5	CLB4	CLB3	CLB2	CLB1	CLB0

Figure 6. Register Summary

Note that the only sticky bit in any of the AD1845 control registers is the interrupt (INT) bit. All other bits can change with every sample period.

# AD1845

## DIRECT CONTROL REGISTER DEFINITIONS

### Index Address Register (ADR1:0 = 0)

ADR1:0	Data 7	Data 6	Data 5	Data 4	Data 3	Data 2	Data 1	Data 0
0	INIT	MCE	TRD	IXA4	IXA3	IXA2	IXA1	IXA0

- IXA4:0** Index Address. These bits define the address of the AD1845 register accessed by the Indexed Data Register. These bits are read/write. IXA4 is not active in MODE1. Always write 0 to this bit when using the AD1845 in MODE1.
- TRD** Transfer Request Disable. This bit, when set, causes PIO and DMA transfers to cease when the Interrupt Status (INT) bit of the Status Register is set.
- 0 Transfers Enabled During Interrupt. PDRQ and CDRQ pin outputs are generated uninhibited by interrupts. DMA Current Counter Register decrements with every sample transferred when either PEN or CEN are enabled.
- 1 Transfers Disabled By Interrupt. PDRQ and CDRQ pin outputs are generated only if INT bit is 0 (when either PEN or CEN, respectively are enabled). Any pending playback or capture requests are allowed to complete at the time when INT is set. After pending requests complete, the data in the FIFO will be consumed at the sample rate. Subsequently, the midscale inputs will be internally generated for the DACs if the DACZ bit is set, otherwise, the previous valid sample will be repeated, and the ADC output buffer will contain the last valid output. Clearing the sticky INT bit (or the TRD bit) will cause the resumption of playback and/or capture requests (presuming PEN and/or CEN are enabled). The DMA Current Counter Register will not decrement while both the TRD bit is set and the INT bit is a one. No over run or under run error will be reported when transfers are disabled by INT.
- MCE** Mode Change Enable. This bit must be set whenever the current functional mode of the AD1845 is changed where noted in the Indirect Control Registers 8, 9, 28 and 29. MCE must be cleared at the completion of the desired register changes.
- The DAC outputs are automatically muted when the MCE bit is set. After MCE is cleared, the DAC outputs will be restored to the state specified by the LDM and RDM mute bits.
- Both ADCs and DACs are automatically muted for 32 sample cycles after exiting the MCE state to allow the reference and all filters to settle. The ADCs will produce midscale values; the DACs' analog output will be muted. All converters are internally operating during these 32 sample cycles, and the AD1845 will expect playback data and will generate (midscale) capture data. Note that the autocalibrate-in-progress (ACI) bit will be set on exiting from the MCE state only when ACAL is set. If ACAL bit is set, ACI will remain HI for these 384 sample cycles, allowing system software to poll this bit rather than count cycles.
- Special sequences must be followed if autocalibrate (ACAL) is set during mode change enable. See the "Autocalibration" section.
- INIT** AD1845 Initialization. This bit is set when the AD1845 cannot respond to parallel bus cycles. This bit is read-only.

Immediately after reset and once the AD1845 has left the INIT state, the initial value of this register will be "0100 0000 (40h)." During AD1845 initialization, this register cannot be written and always reads "1000 0000 (80h)."

### Indexed Data Register (ADR1:0 = 1)

ADR1:0	Data 7	Data 6	Data 5	Data 4	Data 3	Data 2	Data 1	Data 0
1	IXD7	IXD6	IXD5	IXD4	IXD3	IXD2	IXD1	IXD0

- IXD7:0** Indexed Register Data. These bits contain the contents of the AD1845 register referenced by the Indexed Data Register.
- During AD1845 initialization, this register cannot be written and always reads as "1000 0000 (80h)."

**Status Register (ADR1:0 = 2)**

ADR1:0	Data 7	Data 6	Data 5	Data 4	Data 3	Data 2	Data 1	Data 0
2	CU/L	CL/R	CRDY	SOUR	PU/L	PL/R	PRDY	INT

INT	Interrupt Status. This sticky bit (the only one) indicates the status of the interrupt logic of the AD1845. This bit is cleared by any host write of any value to this register. The IEN bit of the Pin Control Register determines whether the state of this bit is reflected on the INT pin of the AD1845. The only interrupt conditions supported by the AD1845 are generated by the underflow of the DMA Current Count Register or the Timer Registers. The Timer Register operates at a 10 $\mu$ s resolution. Clearing INT requires a 10 $\mu$ s wait. If an immediate clearing of a TI condition is desired, clear the TE bit to remove the timer interrupt. 0 Interrupt pin inactive 1 Interrupt pin active
PRDY	Playback Data Register Ready. The PIO or DMA Playback Data Register is ready for more data. This bit is intended to be used when direct programmed I/O data transfers are desired; however, it is also valid for DMA transfers. This bit is read-only. 0 DAC data is still valid. Do not overwrite. 1 DAC data is stale. Ready for next host data write value.
PL/R	Playback Left/Right Sample. This bit indicates whether the PIO or DMA playback data needed is for the right channel DAC or left channel DAC. This bit is read-only. 0 Right channel needed 1 Left channel or mono
PU/L	Playback Upper/Lower Byte. This bit indicates whether the PIO or DMA playback data needed is for the upper or lower byte of the channel. This bit is read-only. 0 Lower byte needed 1 Upper byte needed or any 8-bit mode
SOUR	Sample Over/Underrun. This bit indicates that the most recent sample was not serviced in time and therefore either a capture overrun (COR) or playback underrun (PUR) has occurred. The bit indicates an overrun for ADC capture and an underrun for DAC playback. If both capture and playback are enabled, the source that set this bit can be determined by reading COR and PUR. This bit changes on a sample by sample basis. This bit is read-only.
CRDY	Capture Data Ready. The PIO Capture Data Register contains data ready for reading by the host. This bit should only be used when direct programmed I/O data transfers are desired. This bit is read-only. 0 ADC data is stale. Do not reread the information. 1 ADC data is fresh. Ready for next host data read.
CL/R	Capture Left/Right Sample. This bit indicates whether the PIO capture data waiting is for the right channel ADC or left channel ADC. This bit is read-only. 0 Right channel 1 Left channel or mono
CU/L	Capture Upper/Lower Byte. This bit indicates whether the PIO capture data ready is for the upper or lower byte of the channel. This bit is read-only. 0 Lower byte ready 1 Upper byte ready or any 8-bit mode

The PRDY, CRDY, and INT bits of this status register can change asynchronously to host accesses. The host may access this register while the bits are transitioning. The host read may return a zero value just as these bits are changing, for example. A one value would not be read until the next host access.

While the FIFOs have multiple samples available for transfer, the CRDY and PRDY status bits for consecutive samples are approximately 320 ns–600 ns apart.

This register's initial state after reset is "1100 1100."

# AD1845

## **PIO Data Registers (ADR1:0 = 3)**

ADR1:0	Data 7	Data 6	Data 5	Data 4	Data 3	Data 2	Data 1	Data 0
3	CD7	CD6	CD5	CD4	CD3	CD2	CD1	CD0
3	PD7	PD6	PD5	PD4	PD3	PD2	PD1	PD0

The PIO Data Registers are two registers mapped to the same address. Writes send data to the PIO Playback Data Register (PD7:0). Reads will receive data from the PIO Capture Data Register (CD7:0).

During AD1845 initialization, the PIO Playback Data Register cannot be written to and the Capture Data Register is always read as “1000 0000 (80h).”

**CD7:0** PIO Capture Data Register. This is the control register where capture data is read during programmed I/O data transfers.

The reading of this register will increment the capture byte state machine so that the following read will be from the next appropriate byte in the sample. The exact byte which is next to be read can be determined by reading the Status Register. Once all relevant bytes have been read, the state machine will stay pointed to the last byte of the sample until a new sample is received from the ADCs. Once this has occurred, the state machine and Status Register will point to the first byte of the sample.

**PD7:0** PIO Playback Data Register. This is the control register where playback data is written during programmed I/O data transfers.

Writing data to this register will increment the playback byte tracking state machine so that the following write will be to the correct byte of the sample. Once all bytes of a sample have been written, subsequent byte writes to this port are ignored. The state machine is reset when the current sample is sent to the DACs.

## **INDIRECT CONTROL REGISTER DEFINITIONS**

The following control registers are accessed by writing index values to IXA3:0 in the Index Address Register (ADR1:0 = 0) followed by a read/write to the Indexed Data Register (ADR1:0 = 1).

### **Left Input Control (IXA3:0 = 0)**

IXA3:0	Data 7	Data 6	Data 5	Data 4	Data 3	Data 2	Data 1	Data 0
0	LSS1	LSS0	LMGE	res	LIG3	LIG2	LIG1	LIG0

**LIG3:0** Left input gain select. The least significant bit of this gain select represents +1.5 dB. Maximum gain is +22.5 dB.

**res** Reserved for future expansion. Always write a zero to this bit.

**LMGE** Left Input Microphone Gain Enable. This bit will enable the +20 dB gain of the left MIC input signal.

**LSS1:0** Left Input Source Select. These bits select the input source for the left gain stage preceding the left ADC.

LSS1	LSS0	Left Input Source
0	0	Left Line Source Selected
0	1	Left Auxiliary 1 Source Selected
1	0	Left Microphone Source Selected
1	1	Left Line Post-Mixed DAC Output Source Selected

This register’s initial state after reset is “000x 0000.”

### **Right Input Control (IXA3:0 = 1)**

IXA3:0	Data 7	Data 6	Data 5	Data 4	Data 3	Data 2	Data 1	Data 0
1	RSS1	RSS0	RMGE	res	RIG3	RIG2	RIG1	RIG0

**RIG3:0** Right Input Gain Select. The least significant bit of this gain select represents +1.5 dB. Maximum gain is +22.5 dB.

**res** Reserved for future expansion. Always write a zero to this bit.

**RMGE** Right Input Microphone Gain Enable. This bit will enable the +20 dB gain of the right MIC input signal.

**RSS1:0** Right Input Source Select. These bits select the input source for the right channel gain stage preceding the right ADC.

RSS1	RSS0	Right Input Source
0	0	Right Line Source Selected
0	1	Right Auxiliary 1 Source Selected
1	0	Right Microphone Source Selected
1	1	Right Post-Mixed DAC Output Source Selected

This register's initial state after reset is "000x 0000."

#### Left Auxiliary #1 Input Control (IXA3:0 = 2)

IXA3:0	Data 7	Data 6	Data 5	Data 4	Data 3	Data 2	Data 1	Data 0
2	LMX1	res	res	LX1A4	LX1A3	LX1A2	LX1A1	LX1A0

LX1A4:0 Left Auxiliary Input #1 Attenuate Select. The least significant bit of this gain/attenuate select represents 1.5 dB. LX1A4:0 = 0 produces a +12 dB gain. LX1A4:0 = "01000" (8 decimal) produces 0 dB gain. Maximum attenuation is -34.5 dB. See Figure 10.

res Reserved for future expansion. Always write zeros to these bits.

LMX1 Left Auxiliary #1 Mute. This bit, when set, will mute the left channel of the Auxiliary #1 input source. This bit powers up set.

This register's initial state after reset is "1xx0 1000."

#### Right Auxiliary #1 Input Control (IXA3:0 = 3)

IXA3:0	Data 7	Data 6	Data 5	Data 4	Data 3	Data 2	Data 1	Data 0
3	RMX1	res	res	RX1A4	RX1A3	RX1A2	RX1A1	RX1A0

RX1A4:0 Right Auxiliary Input #1 Attenuate Select. The least significant bit of this gain/attenuate select represents 1.5 dB. RX1A4:0 = 0 produces a +12 dB gain. RX1A4:0 = "01000" (8 decimal) produces 0 dB gain. Maximum attenuation is -34.5 dB. See Figure 10.

res Reserved for future expansion. Always write zeros to these bits.

RMX1 Right Auxiliary #1 Mute. This bit, when set, will mute the right channel of the Auxiliary #1 input source. This bit powers up set.

This register's initial state after reset is "1xx0 1000."

#### Left Auxiliary #2 Input Control (IXA3:0 = 4)

IXA3:0	Data 7	Data 6	Data 5	Data 4	Data 3	Data 2	Data 1	Data 0
4	LMX2	res	res	LX2A4	LX2A3	LX2A2	LX2A1	LX2A0

LX2A4:0 Left Auxiliary Input #2 Attenuate Select. The least significant bit of this gain/attenuate select represents 1.5 dB. LX2A4:0 = 0 produces a +12 dB gain. LX2A4:0 = "01000" (8 decimal) produces 0 dB gain. Maximum attenuation is -34.5 dB. See Figure 10.

res Reserved for future expansion. Always write zeros to these bits.

LMX2 Left Auxiliary #2 Mute. This bit, when set to 1, will mute the left channel of the Auxiliary #2 input source. This bit powers up set.

This register's initial state after reset is "1xx0 1000."

#### Right Auxiliary #2 Input Control (IXA3:0 = 5)

IXA3:0	Data 7	Data 6	Data 5	Data 4	Data 3	Data 2	Data 1	Data 0
5	RMX2	res	res	RX2A4	RX2A3	RX2A2	RX2A1	RX2A0

# AD1845

**RX2A4:0** Right Auxiliary Input #2 Attenuate Select. The least significant bit of this gain/attenuate select represents 1.5 dB. RX2A4:0 = 0 produces a +12 dB gain. RX2A4:0 = "01000" (8 decimal) produces 0 dB gain. Maximum attenuation is -34.5 dB. See Figure 10.

**res** Reserved for future expansion. Always write zeros to these bits.

**RMX2** Right Auxiliary #2 Mute. This bit, when set, will mute the right channel of the Auxiliary #2 input source. This bit powers up set.

This register's initial state after reset is "1xx0 1000."

## Left DAC Control (IXA3:0 = 6)

IXA3:0	Data 7	Data 6	Data 5	Data 4	Data 3	Data 2	Data 1	Data 0
6	LDM	res	LDA5	LDA4	LDA3	LDA2	LDA1	LDA0

**LDA5:0** Left DAC Attenuate Select. The least significant bit of this gain/attenuate select represents 1.5 dB. Maximum attenuation is -94.5 dB. See Figure 7.

**res** Reserved for future expansion. Always write a zero to this bit.

**LDM** Left DAC Mute. This bit, when set to 1, will mute the left DAC output. This bit powers up active.

This register's initial state after reset is "1x00 0000."

## Right DAC Control (IXA3:0 = 7)

IXA3:0	Data 7	Data 6	Data 5	Data 4	Data 3	Data 2	Data 1	Data 0
7	RDM	res	RDA5	RDA4	RDA3	RDA2	RDA1	RDA0

**RDA5:0** Right DAC Attenuate Select. The least significant bit of this gain/attenuate select represents 1.5 dB. Maximum attenuation is -94.5 dB. See Figure 7.

**res** Reserved for future expansion. Always write a zero to this bit.

**RDM** Right DAC Mute. This bit, when set to 1, will mute the right DAC output. This bit powers up active.

This register's initial state after reset is "1x00 0000."

A5	A4	A3	A2	A1	A0	Mix Gain
0	0	0	0	0	0	0 dB
0	0	0	0	0	1	-1.5 dB
0	0	0	0	1	0	-3.0 dB
0	0	0	0	1	1	-4.5 dB
0	0	0	1	0	0	-6.0 dB
0	0	0	1	0	1	-7.5 dB
0	0	0	1	1	0	-9.0 dB
0	0	0	1	1	1	-10.5 dB
0	0	1	0	0	0	-12.0 dB
0	0	1	0	0	1	-13.5 dB
0	0	1	0	1	0	-15.0 dB
0	0	1	0	1	1	-16.5 dB
•		•	•	•	•	• •
•		•	•	•	•	• •
•		•	•	•	•	• •
1	1	0	1	0	0	-78.0 dB
1	1	0	1	0	1	-79.5 dB
1	1	0	1	1	0	-81.0 dB
1	1	0	1	1	1	-82.5 dB
1	1	1	0	0	0	-84.0 dB
1	1	1	0	0	1	-85.5 dB
1	1	1	0	1	0	-87.0 dB
1	1	1	0	1	1	-88.5 dB
1	1	1	1	0	0	-90.0 dB
1	1	1	1	0	1	-91.5 dB
1	1	1	1	1	0	-93.0 dB
1	1	1	1	1	1	-94.5 dB

Figure 7. Mix Gain Level Setting: DAC

**Clock and Data Format Register (IXA3:0 = 8)**

IXA3:0	Data 7	Data 6	Data 5	Data 4	Data 3	Data 2	Data 1	Data 0
8	FMT1	FMT0	C/L	S/M	CFS2	CFS1	CFS0	CSS

NOTE: Placing the AD1845 in the Mode Change Enable (MCE) state is not required when changing the sample rate. However, changes to FMT[1:0], C/L, and S/M require MCE or setting PEN = 0.

**CSS** Clock Source Select. This bit in conjunction with CFS2:0 selects the audio sample rate frequency. See Figure 8 below. Note: MODE2 allows a wider range of sample rate frequencies to be selected by using the Frequency Select Register (refer to Registers 22 and 23).

**CFS2:0** Clock Frequency Divide Select. These bits in conjunction with CSS select the audio sample frequency.

CFS2	CFS1	CFS0	CSS	Sample Rate
0	0	0	0	8.0 kHz
0	0	0	1	5.5125 kHz
0	0	1	0	16.0 kHz
0	0	1	1	11.025 kHz
0	1	0	0	27.42857 kHz
0	1	0	1	18.9 kHz
0	1	1	0	32.0 kHz
0	1	1	1	22.05 kHz
1	0	0	0	Reserved
1	0	0	1	37.8 kHz
1	0	1	0	Reserved
1	0	1	1	44.1 kHz
1	1	0	0	48.0 kHz
1	1	0	1	33.075 kHz
1	1	1	0	9.6 kHz
1	1	1	1	6.615 kHz

Figure 8. MODE1 Audio Sample Frequency Select

**S/M** Stereo/Mono Select. This bit determines how the audio data streams are formatted. Selecting stereo will result with alternating samples representing left and right audio channels. Mono playback plays the same audio sample on both channels. Mono capture only captures data from the left audio channel.

0 Mono  
1 Stereo

**C/L** Companded/Linear Select. This bit selects between a linear digital representation of the audio signal or a nonlinear, companded format for all input and output data. The type of linear PCM or the type of companded format is defined by the FMT bits.

0 Linear PCM  
1 Companded

**FMT[1:0]** Format Select. The bits define the format for all digital audio input and outputs based on the state of the C/L bit. See Figure 9 for FMT and C/L bit settings that determine the audio data type format.

**res** Reserved for future expansion. Always write a zero to this bit.

This register's initial state after reset is "0000 0000."

FMT1	FMT0	C/L	Audio Data Type
0	0	0	Linear, 8-Bit Unsigned PCM
0	0	1	μ-Law, 8-Bit Companded
0	1	0	Linear, 16-Bit Twos-Complement PCM Little Endian
0	1	1	A-Law, 8-Bit Companded
1	0	0	Reserved
1	0	1	Reserved
1	1	0	Linear, 16-Bit Twos Complement Big Endian
1	1	1	Reserved

Figure 9. Digital Audio Data Type

# AD1845

## Interface Configuration Register (IXA3:0 = 9)

IXA3:0	Data 7	Data 6	Data 5	Data 4	Data 3	Data 2	Data 1	Data 0
9	CPIO	PPIO	res	res	ACAL	SDC	CEN	PEN

NOTE: Placing the AD1845 in the Mode Change Enable (MCE) state is not required when changing the CEN and PEN bits in this register.

PEN	Playback Enable. This bit will enable the playback of data in the format selected. The AD1845 will generate PDRQ and respond to $\overline{\text{PDAK}}$ signals when this bit is enabled and PPIO = 0. If PPIO = 1, this bit enables Programmed I/O (PIO) playback mode. 0 Playback disabled (PDRQ and PIO Playback Data Register inactive) 1 Playback enabled
CEN	Capture Enable. This bit will enable the capture of data in the format selected. The AD1845 will generate CDRQ and respond to $\overline{\text{CDAK}}$ signals when this bit is enabled and CPIO = 0. If CPIO = 1, this bit enables PIO capture mode. 0 Capture disable (CDRQ and PIO Capture Data Register inactive) 1 Capture enable
SDC	Single DMA Channel. This bit will force both capture and playback DMA requests to occur on the Playback DMA channel. The Capture DMA CDRQ pin will be LO. This bit will allow the AD1845 to be used with only one DMA channel. Simultaneous capture and playback cannot occur in this mode. Should both capture and playback be enabled (CEN=PEN=1) in the mode, only playback will occur. See “Data and Control Transfers” for further explanation. 0 Dual DMA channel mode 1 Single DMA channel mode
ACAL	Autocalibrate Enable. This bit determines whether the AD1845 performs an autocalibration whenever the Mode Change Enable (MCE) bit changes from HI to LO. See “Autocalibration” for a description of a complete autocalibration sequence. Note that an autocalibration is forced whenever the $\overline{\text{RESET}}$ or $\overline{\text{PWRDWN}}$ pin is asserted LO then transitions HI regardless of the state of the ACAL bit. 0 No autocalibration 1 Autocalibration after mode change
res	Reserved for future expansion. Always write zeros to these bits.
PPIO	Playback PIO Enable. This bit determines whether the playback data is transferred via DMA or PIO. 0 DMA transfers only 1 PIO transfers only
CPIO	Capture PIO Enable. This bit determines whether the capture data is transferred via DMA or PIO. 0 DMA transfers only 1 PIO transfers only

This register’s initial state after reset is “00xx 1000.”

## Pin Control Register (IXA3:0 = 10)

IXA3:0	Data 7	Data 6	Data 5	Data 4	Data 3	Data 2	Data 1	Data 0
10	XCTL1	XCTL0	res	res	res	res	IEN	INITD

INITD	Disable setting the INIT bit after changing the sample rate in MODE1. Otherwise the INIT bit is set HI for approximately 200 $\mu\text{s}$ after changing the sample rate. 0 INIT bit is enabled 1 INIT bit is disabled
IEN	Interrupt Enable. This bit enables the interrupt pin. The Interrupt Pin will go active HI when the number of samples programmed in the Base Count Register is reached. 0 Interrupt disabled 1 Interrupt enabled
res	Reserved for future expansion. Always write zeros to these bits.

XCTL1:0 External Control. The state of these bits is reflected on the XCTL1:0 pins of the AD1845.  
 0 Logic LO on XCTL1:0 pins  
 1 Logic HI on XCTL1:0 pins

This register's initial state after reset is "00xx xx00."

**Test and Initialization Register (IXA3:0 = 11)**

IXA3:0	Data 7	Data 6	Data 5	Data 4	Data 3	Data 2	Data 1	Data 0
11	COR	PUR	ACI	DRS	ORR1	ORR0	ORL1	ORL0

ORL1:0 Overrange Left Detect. These bits indicate the overrange on the left capture channel. These bits change on a sample-by-sample basis, and are read-only.

ORL1	ORL0	
0	0	Less than -1 dB underrange
0	1	Between -1 dB and 0 dB underrange
1	0	Between 0 dB and +1 dB overrange
1	1	Greater than +1 dB overrange

ORR1:0 Overrange Right Detect. These bits indicate the overrange on the right capture channel. These bits change on a sample-by-sample basis, and are read-only.

ORR1	ORR0	
0	0	Less than -1 dB underrange
0	1	Between -1 dB and 0 dB underrange
1	0	Between 0 dB and +1 dB overrange
1	1	Greater than +1 dB overrange

DRS Data Request Status. This bit indicates the current status of the PDRQ and CDRQ pins of the AD1845.

0	CDRQ and PDRQ are presently inactive (LO)
1	CDRQ or PDRQ are presently active (HI)

ACI Autocalibrate-In-Progress. This bit indicates the state of autocalibration or a recent exit from Mode Change Enable (MCE). This bit is read-only.

0	Autocalibration is not in progress
1	Autocalibration is in progress or MCE was exited within the last 128 sample periods

PUR Playback Underrun. This bit is set when the playback FIFO is empty and after the next valid sample has been played back. If this condition exists, DACZ determines the DAC playback value. In MODE1, DACZ is always set and returns a midscale value.

COR Capture Overrun. This bit is set when the capture FIFO is full and an additional sample has been captured. The sample being read will not be overwritten by the new sample. The new sample will be ignored. This bit changes on a sample by sample basis.

The occurrence of a PUR and/or COR is designated in the Status Register's Sample Overrun/Underrun (SOUR) bit. The SOUR bit is the logical OR of the COR and PUR bits. This enables a polling host CPU to detect an overrun/underrun condition while checking other status bits.

This register's initial state after reset is "0000 0000."

**Miscellaneous Control Register (IXA3:0 = 12)**

IXA3:0	Data 7	Data 6	Data 5	Data 4	Data 3	Data 2	Data 1	Data 0
12	MID	MODE2	res	BUF8	ID3	ID2	ID1	ID0

ID3:0 AD1845 Revision ID. These four bits define the revision level of the AD1845. The AD1845 will have ID = "1010." These bits are read-only.

BUF8 Parallel Interface Bus Transceiver Current Buffer Drive. The AD1845 can be programmed to provide a current drive of 16 mA or 8 mA.

0	16 mA current drive.
1	8 mA current drive.

res Reserved for future expansion. Always write 0s to these bits.

# AD1845

**MODE2** When the AD1845 is initialized, the MODE2 bit is set to 0, LO, and the AD1845 is register set compatible with the AD1848 and the AD1846. Setting the MODE2 bit to 1, HI, enables access to the indirect registers 16 through 31 which controls the AD1845 Expanded Mode of operation.

- 0 MODE1: AD1848, AD1846, and CS4248 mode
- 1 MODE2: AD1845 enhanced feature mode

**MID** Manufacturer ID Bit. This bit is set to 1.

This register's initial state after reset is "10x0 1010."

## Digital Mix/Attenuation Control Register (IXA3:0 = 13)

IXA3:0	Data 7	Data 6	Data 5	Data 4	Data 3	Data 2	Data 1	Data 0
13	DMA5	DMA4	DMA3	DMA2	DMA1	DMA0	res	DME

**DME** Digital Mix Enable. This bit will enable the digital mix of the ADC's output with the DAC's input. When enabled, the data from the ADCs are digitally mixed with other data being delivered to the DACs regardless of whether or not playback is enabled (PEN = 1). If capture is enabled (CEN = 1) and there is a capture overrun (COR), then the last sample captured before overrun will be used for the digital mix. If playback is enabled (PEN = 1) and there is a playback underrun (PUR), then a midscale zero will be added to the digital mix data if DACZ = 1, otherwise, the last valid sample will be repeated.

- 0 Digital mix disabled (muted)
- 1 Digital mix enabled

**res** Reserved for future expansion. Always write a zero to this bit.

**DMA5:0** Digital Mix Attenuation. These bits determine the attenuation of the ADC data that is mixed with the DAC input. Each attenuate step is -1.5 dB ranging from 0 dB to -94.5 dB.

This register's initial state after reset is "0000 00x0."

## DMA Playback Base Count Registers (IXA3:0 = 14 & 15)

The DMA Base Count Registers in the AD1845 simplify integration of the AD1845 in ISA systems. The ISA DMA controller requires an external count mechanism to notify the host CPU via interrupt of a full DMA buffer. The programmable DMA Base Count Registers will allow such interrupts to occur.

The Base Count Registers contain the number of samples to be transferred before an interrupt is generated on the interrupt (INT) pin. To load, first write a value to the Lower Base Count Register. Writing a value to the Upper Base Register will cause both Base Count Registers to load into the Current Count Register. Once AD1845 transfers are enabled, each sample transferred causes the Current Count Register to decrement until zero count is reached. The next sample after zero will generate the interrupt and reload the Current Count Register with the values in the Base Count Registers. The interrupt is cleared by a write to the Status Register.

The Host Interrupt Pin (INT) will go HI during the sample period in which the Current Count Register underflows.

When using the AD1845 in MODE1 (AD1848 compatible), the Current Count Register is decremented every sample period when either the PEN or CEN bit is enabled. The Current Count Register is decremented in both PIO and DMA data transfer modes. Interrupt conditions are generated by Current Count Register underflows in both PIO and DMA transfers.

Program maximum value to the Upper Base Count Register to avoid receiving DMA count interrupts while operating in PIO mode. By enabling MODE2, the AD1845 Expanded Mode, the playback counter is only decremented when a playback sample transfer occurs.

## Upper Base Count Register (IXA3:0 = 14)

IXA3:0	Data 7	Data 6	Data 5	Data 4	Data 3	Data 2	Data 1	Data 0
14	UB7	UB6	UB5	UB4	UB3	UB2	UB1	UB0

**UB7:0** Upper Base Count. This byte is the upper byte of the base count register containing the eight most significant bits of the 16-bit base register. Reads from this register return the same value which was written. The current count contained in the counters can not be read.

This register's initial state after reset is " 0000 0000."

**Lower Base Count Register (IXA3:0 = 15)**

IXA3:0	Data 7	Data 6	Data 5	Data 4	Data 3	Data 2	Data 1	Data 0
15	LB7	LB6	LB5	LB4	LB3	LB2	LB1	LB0

LB7:0 Lower Base Count. This byte is the lower byte of the base count register containing the eight least significant bits of the 16-bit base register. Reads from this register return the same value which was written. The current count contained in the counters cannot be read.

This register's initial state after reset is "0000 0000."

**Expanded Modes (MODE2 = 1)**

The following registers are enabled when the AD1845 is operating in MODE2 only.

**Alternate Feature Enable/Left MIC Input Control Register (IXA3:0 = 16)**

IXA3:0	Data 7	Data 6	Data 5	Data 4	Data 3	Data 2	Data 1	Data 0
16	OL	TE	LMG4	LMG3	LMG2	LMG1	LMG0	DACZ

DACZ DAC Zero. When an underrun error occurs, this bit will force the DAC output to midscale.

0 Output previous valid sample

1 Output to midscale value

LMG4:0 Left MIC Gain. The least significant bit of this gain/attenuate select represents 1.5 dB. LMG4:0 = 0 produces a +12 dB gain. LMG4:0 = "01000" (8 decimal) produces 0 dB gain. Maximum attenuation is -34.5 dB. See Figure 10.

TE Timer Enable. Setting this bit enables the 16-bit programmable timer (see Registers 20 and 21). When the timer is enabled, the timer count is reloaded, and interrupts are generated at specified periods on the INT pin. When the timer is disabled, the timer stops counting and the INT pin and TI bit are cleared immediately.

OL Output Level. This bit sets the analog output level. The line output level may be attenuated by 3 dB.

0 Full scale of 2.0 V p-p (-3 dB)

1 Full scale of 2.8 V p-p (0 dB)

This register's initial state after reset is "0001 0001."

**MIC Mix Enable/Right MIC Input Control Register (IXA3:0 = 17)**

IXA3:0	Data 7	Data 6	Data 5	Data 4	Data 3	Data 2	Data 1	Data 0
17	LMME	RMME	RMG4	RMG3	RMG2	RMG1	RMG0	res

res Reserved for future expansion. Always write zero to this bit.

RMG4:0 Right MIC Gain. The least significant bit of this gain/attenuate select represents 1.5 dB. RMG4:0 = 0 produces a +12 dB gain. RMG4:0 = "01000" (8 decimal) produces 0 dB gain. Maximum attenuation is -34.5 dB. See Figure 10.

RMME Right MIC Mix Enable. Setting this bit enables the right microphone input to be mixed with the DAC output on R\_OUT.

LMME Left MIC Mix Enable. Setting this bit enables the left microphone input to be mixed with the DAC output on L\_OUT.

This register's initial state after reset is "0001 000x."

**Left Line Gain, Attenuate, Mute Mix Register (IXA3:0 = 18)**

IXA3:0	Data 7	Data 6	Data 5	Data 4	Data 3	Data 2	Data 1	Data 0
18	LLM	res	res	LLG4	LLG3	LLG2	LLG1	LLG0

LLG4:0 Left Line Mix Gain. Allows setting the left line mix gain in thirty-two 1.5 dB steps. See Figure 10 for mix gain level setting.

res Reserved for future expansion. Always write zeros to these bits.

# AD1845

LLM Left Line Mute. Setting this bit to 1 mutes the left line input into the output mixer.

This register's initial state after reset is "1xx0 1000."

## Right Line Gain, Attenuate, Mute, Mix Register (IXA3:0 = 19)

IXA3:0	Data 7	Data 6	Data 5	Data 4	Data 3	Data 2	Data 1	Data 0
19	RLM	res	res	RLG4	RLG3	RLG2	RLG1	RLG0

RLG4:0 Right Line Mix Gain. Allows setting the right line mix gain in thirty-two 1.5 dB steps. See Figure 10 for mix gain level setting.

res Reserved for future expansion. Always write zeros to these bits.

RLM Right Line Mute. Setting this bit to 1 mutes the right line input into the output mixer.

This register's initial state after reset is "1xx0 1000."

A4/G4	A3/G3	A2/G2	A1/G1	A0/G0	Mix Gain
0	0	0	0	0	+12.0 dB
0	0	0	0	1	+10.5 dB
0	0	0	1	0	+9.0 dB
0	0	0	1	1	+7.5 dB
0	0	1	0	0	+6.0 dB
0	0	1	0	1	+4.5 dB
0	0	1	1	0	+3.0 dB
0	0	1	1	1	+1.5 dB
0	1	0	0	0	+0.0 dB
0	1	0	0	1	-1.5 dB
0	1	0	1	0	-3.0 dB
0	1	0	1	1	-4.5 dB
0	1	1	0	0	-6.0 dB
0	1	1	0	1	-7.5 dB
0	1	1	1	0	-9.0 dB
0	1	1	1	1	-10.5 dB
1	0	0	0	0	-12.0 dB
1	0	0	0	1	-13.5 dB
1	0	0	1	0	-15.0 dB
1	0	0	1	1	-16.5 dB
1	0	1	0	0	-18.0 dB
1	0	1	0	1	-19.5 dB
1	0	1	1	0	-21.0 dB
1	0	1	1	1	-22.5 dB
1	1	0	0	0	-24.0 dB
1	1	0	0	1	-25.5 dB
1	1	0	1	0	-27.0 dB
1	1	0	1	1	-28.5 dB
1	1	1	0	0	-30.0 dB
1	1	1	0	1	-31.5 dB
1	1	1	1	0	-33.0 dB
1	1	1	1	1	-34.5 dB

Figure 10. Mix Gain Level Setting: AUX1, AUX2, MIC and LINE

## Lower Timer Bits Register (IXA3:0 = 20)

IXA3:0	Data 7	Data 6	Data 5	Data 4	Data 3	Data 2	Data 1	Data 0
20	TL7	TL6	TL5	TL4	TL3	TL2	TL1	TL0

TL7:0 Lower Timer Bits. This byte is the lower byte of the timer register containing the eight least significant bits of the 16-bit register. Reads from this register return the same value which was written. The current timer value contained in the counters cannot be read.

This register's initial state after reset is "0000 0000."

**Upper Timer Bits Register (IXA3:0 = 21)**

IXA3:0	Data 7	Data 6	Data 5	Data 4	Data 3	Data 2	Data 1	Data 0
21	TU7	TU6	TU5	TU4	TU3	TU2	TU1	TU0

TU7:0 Upper Timer Bits. This byte is the upper byte of the timer register containing the eight most significant bits of the 16-bit register. Reads from this register return the same value which was written. The current timer value contained in the counters cannot be read. The timer counter is determined by the clock source selected (see below).

Input Frequency	Divider	Timer Counter
24.576 MHz	247	10.050 $\mu$ s
14.31818 MHz	144	10.057 $\mu$ s
24.000 MHz	242	10.083 $\mu$ s
25.000 MHz	252	10.080 $\mu$ s
33.000 MHz	333	10.091 $\mu$ s

This register's initial state after reset is "0000 0000."

**Upper Frequency Select Bits Register (IXA3:0 = 22)**

IXA3:0	Data 7	Data 6	Data 5	Data 4	Data 3	Data 2	Data 1	Data 0
22	FU7	FU6	FU5	FU4	FU3	FU2	FU1	FU0

FU7:0 Upper Frequency Select Bits. This register is accessible when FREN is 1. Writing to this register allows the user to program the sampling frequency from 4 kHz to 50 kHz in 1 Hz increments. Writing to the Lower and Upper Frequency Select Register allows the AD1845 to process audio data using approximately 50,000 different audio sample rates. One LSB represents exactly one hertz. Selecting frequencies below 4 kHz or above 50 kHz will result in degraded audio performance. Some common sample rates are listed below:

Quality	Sampling Frequency	FU7:0 (hex)	FL7:0 (hex)	
Voice	8.0 kHz	0001 1111	0100 0000	default
Radio	11.025 kHz	0010 1011	0001 0001	
Tape	22.05 kHz	0101 0110	0010 0010	
CD	44.1 kHz	1010 1100	0100 0100	
DAT	48.0 kHz	1011 1011	1000 0000	

This register's initial state after reset is "0001 1111."

**Lower Frequency Select Bits Register (IXA3:0 = 23)**

IXA3:0	Data 7	Data 6	Data 5	Data 4	Data 3	Data 2	Data 1	Data 0
23	FL7	FL6	FL5	FL4	FL3	FL2	FL1	FL0

FL7:0 Lower Frequency Select Bits. Writing to the Lower Frequency Select register updates the entire 16-bit frequency register. This register's initial state after reset is "0100 0000."

**Capture Playback Timer Register (IXA3:0 = 24)**

IXA3:0	Data 7	Data 6	Data 5	Data 4	Data 3	Data 2	Data 1	Data 0
24	res	TI	CI	PI	CU	CO	PO	PU

PU Playback Underrun. This bit is set when the DAC runs out of data and a sample has been missed.

PO Playback Overrun. This bit is set when the host tries to write data into the FIFO and the write was ignored because the FIFO was full.

CO Capture Overrun. This bit is set when the ADC has a sample to load into the FIFO, and the data was ignored because the capture FIFO was full.

CU Capture Underrun. This bit is set when the host attempts to read from the capture FIFO when it is empty. Under these circumstances, the last valid byte is sent to the host.

PI Playback Interrupt. This bit indicates that there is an interrupt pending from the playback DMA count registers.

CI Capture Interrupt. This bit indicates that there is an interrupt pending from the capture DMA count registers.

# AD1845

TI Timer Interrupt. This bit indicates that there is an interrupt pending from the timer count registers.  
 res Reserved for future expansion. Always write zero to this bit.

Playback, Capture and timer interrupts may be cleared simultaneously by writing to the Status Register. These interrupts may be cleared individually by writing a “0” to the corresponding bit. Note that the timer interrupt requires a minimum wait period of 10 μs after the interrupt is set and before TI is recognized. Use TE to clear the timer interrupt immediately.

This register’s initial state after reset is “100x x000.”

## Revision ID Register (IXA3:0 = 25)

IXA3:0	Data 7	Data 6	Data 5	Data 4	Data 3	Data 2	Data 1	Data 0
25	V2	V1	V0	res	res	CID2	CID1	CID0

V2:0 Version Number. Indicates the version of the AD1845.  
 res Reserved for future expansion. Always write zeros to these bits.  
 CID2:0 Chip ID Number.

This register’s initial state after reset is “x000 0000.”

## Mono Control Registers (IXA3:0 = 26)

IXA3:0	Data 7	Data 6	Data 5	Data 4	Data 3	Data 2	Data 1	Data 0
26	MIM	MOM	res	res	MIA3	MIA2	MIA1	MIA0

MIA3:0 Mono Input Attenuation. The least significant bit represents 3.0 dB attenuation. See Figure 11 to determine the attenuation.  
 res Reserved for future expansion. Always write zeros to these bits.  
 MOM Mono Output Mute. M\_OUT is muted by setting MOM to 1.  
 0 Mono output not muted  
 1 Mono output muted  
 MIM Mono Input Mute. M\_IN is muted by setting MIM to 1.  
 0 Mono input not muted  
 1 Mono input muted

This register’s initial state after reset is “00xx 0011.”

MIA3	MIA2	MIA1	MIA0	MONO Attenuation
0	0	0	0	0.0 dB
0	0	0	1	-3.0 dB
0	0	1	0	-6.0 dB
0	0	1	1	-9.0 dB
0	1	0	0	-12.0 dB
0	1	0	1	-15.0 dB
0	1	1	0	-18.0 dB
0	1	1	1	-21.0 dB
1	0	0	0	-24.0 dB
1	0	0	1	-27.0 dB
1	0	1	0	-30.0 dB
1	0	1	1	-33.0 dB
1	1	0	0	-36.0 dB
1	1	0	1	-39.0 dB
1	1	1	0	-42.0 dB
1	1	1	1	-45.0 dB

Figure 11. Mono Attenuation

**Power-Down Control Register (IXA3:0 = 27)**

IXA3:0	Data 7	Data 6	Data 5	Data 4	Data 3	Data 2	Data 1	Data 0
27	ADCPWD	DACPWD	MIXPWD	res	FREN	res	res	res

res Reserved for future expansion. Always write zeros to these bits.

FREN Frequency Select Register Enable. In MODE2, selecting this bit will turn on the Frequency Select Registers (see indirect registers 22 and 23) and disable CFS2:0.

0 CFS Active.

1 Frequency Select Registers Active, CFS disabled.

MIXPWD Mixer Power Down. The DAC and the output mixer are powered down, and the DAC sample clock is turned off.

DACPWD DAC Power Down. The DAC is powered down and the DAC sample clock is turned off.

ADCPWD ADC Power Down. The ADC is powered down and the ADC sample clock is turned off.

This register's initial state after reset is "000x 0xxx."

**Capture Data Format Control Register (IXA3:0 = 28)**

IXA3:0	Data 7	Data 6	Data 5	Data 4	Data 3	Data 2	Data 1	Data 0
28	CFMT1	CFMT0	CC/L	CS/M	res	res	res	res

NOTE: Changing CFMT[1:0], CC/L, CS/M, requires the Mode Change Enable (MCE) state or setting CEN = 0.

res Reserved for future expansion. Always write zeros to these bits.

CS/M Capture Stereo/Mono Select. Setting this bit determines how the captured audio data will be formatted. In the Mono mode, valid information is captured on the "left" channel, and the "right" channel data is not valid.

0 Mono Format

1 Stereo Format

CC/L Capture Companding/Linear Select. This bit is set to determine linear,  $\mu$ -Law or A-Law companding. See Figure 12 for CFMT[1:0] and CC/L bit settings that determine the audio data type capture format.

CFMT[1:0] Capture Data Format. This bit is set to format the data being captured in MODE 2. See Figure 12 for CFMT and CC/L bit settings that determine the capture audio data type format.

This register's initial state after reset is "0000 xxxx."

CFMT1	CFMT0	CC/L	Audio Data Type
0	0	0	Linear, 8-Bit Unsigned PCM
0	0	1	$\mu$ -Law, 8-Bit Companded
0	1	0	Linear, 16-Bit Twos Complement PCM Little Endian
0	1	1	A-Law, 8-Bit Companded
1	0	0	Reserved
1	0	1	Reserved
1	1	0	Linear, 16-Bit Twos-Complement Big Endian
1	1	1	Reserved

Figure 12. Capture Audio Data Type

**Crystal, Clock Select/Total Power-Down Register (IXA3:0 = 29)**

IXA3:0	Data 7	Data 6	Data 5	Data 4	Data 3	Data 2	Data 1	Data 0
29	XFS2	XFS1	XFS0	res	res	res	res	TOTPWD

TOTPWD Total Power Down. When TOTPWD = HI, the ADC, DAC, mixer, and voltage reference are powered down, and the ADC and DAC sample clocks are turned off. Only the digital interface remains active to allow the host to exit the AD1845 from the total power-down state.

res Reserved for future expansion. Always write zeros to these bits.

# AD1845

**XFS2:0** Crystal/Clock Input Frequency Select. On power up or reset, the AD1845 expects a 24.576 MHz input clock. If the clock source connected to the AD1845 is different from the default condition, then the clock input must be selected using this register. For a detailed explanation see the Power Up and Reset section of the data sheet. Figure 13 summarizes the valid input clock frequencies. Clock sources with excessive jitter may not yield optimal analog performance.

This register's initial state after reset is "000x xxx0."

<b>XFS2</b>	<b>XFS1</b>	<b>XFS0</b>	<b>Input Frequency</b>
0	0	0	24.576 MHz
0	0	1	14.31818 MHz
0	1	0	24.000 MHz
0	1	1	25.000 MHz
1	0	0	33.000 MHz
1	0	1	Reserved
1	1	0	Reserved
1	1	1	Reserved

Figure 13. Input Frequency Selection

## Capture Upper Base Count Register (IXA3:0 = 30)

<b>IXA3:0</b>	<b>Data 7</b>	<b>Data 6</b>	<b>Data 5</b>	<b>Data 4</b>	<b>Data 3</b>	<b>Data 2</b>	<b>Data 1</b>	<b>Data 0</b>
30	CUB7	CUB6	CUB5	CUB4	CUB3	CUB2	CUB1	CUB0

**CUB7:0** Capture Upper Base Count. This byte is the upper byte of the base count register containing the eight most significant bits of the second 16-bit base register. Reads from this register return the same value that was written. The current count contained in the counters cannot be read.

This register's initial state after reset is "0000 0000."

## Capture Lower Base Count Register (IXA3:0 = 31)

<b>IXA3:0</b>	<b>Data 7</b>	<b>Data 6</b>	<b>Data 5</b>	<b>Data 4</b>	<b>Data 3</b>	<b>Data 2</b>	<b>Data 1</b>	<b>Data 0</b>
31	CLB7	CLB6	CLB5	CLB4	CLB3	CLB2	CLB1	CLB0

**CLB7:0** Capture Lower Base Count. This byte is the lower byte of the base count register containing the eight least significant bits of the second 16-bit base register. Reads from this register return the same value that was written. The current count contained in the counters cannot be read.

This register's initial state after reset is "0000 0000."

## DATA AND CONTROL TRANSFERS

The AD1845 SoundPort Stereo Codec supports a DMA request/grant architecture for transferring data with the host computer bus. One or two DMA channels can be supported. Programmed I/O (PIO) mode is also supported for control register accesses and for applications lacking DMA control. PIO transfers can be made on one channel while the other is performing DMA. Transfers to and from the AD1845 SoundPort Codec are asynchronous relative to the internal data conversion clock. Transfers are buffered by FIFOs located in the capture and playback paths.

### Data Ordering

The number of byte-wide transfers required depends on the data format selected. The AD1845 is designed for “little and big endian” formats. In little endian format, the least significant byte (i.e., occupying the lowest memory address) gets transferred first. Therefore, 16-bit data transfers require first transferring the least significant bits [7:0] and then transferring the most significant bits [15:8], where Bit 15 is the most significant bit in the word. In big endian format, byte ordering for the most significant (MS) byte and least significant (LS) byte are swapped.

In addition, left channel data is always transferred before right channel data with the AD1845. The following figures should make these requirements clear.

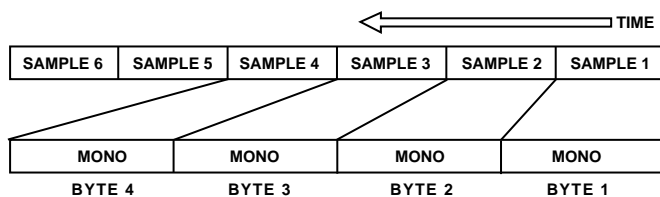

Figure 14. 8-Bit Mono Data Stream Sequencing

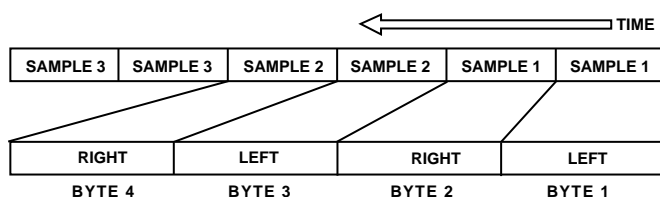

Figure 15. 8-Bit Stereo Data Stream Sequencing

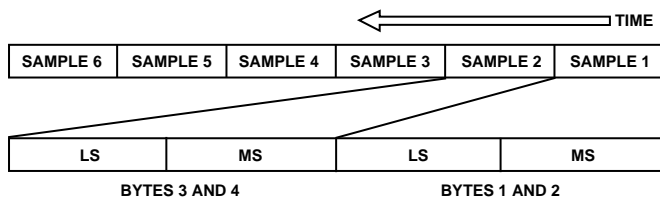

Figure 16. 16-Bit Mono Data Stream Sequencing, Little Endian

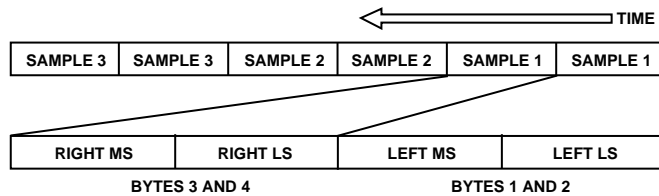

Figure 17. 16-Bit Stereo Data Stream Sequencing, Little Endian

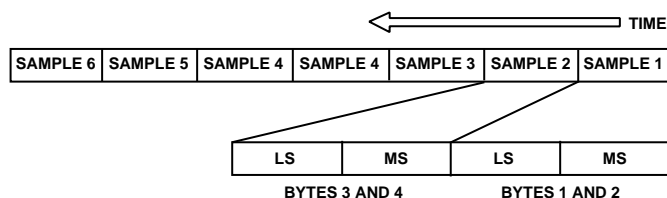

Figure 18. 16-Bit Mono Data Stream Sequencing, Big Endian

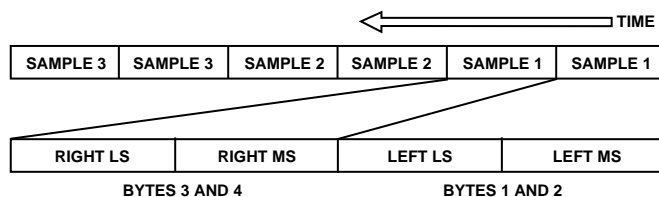

Figure 19. 16-Bit Stereo Data Stream Sequencing, Big Endian

### FIFO

The AD1845 includes two 16-sample deep FIFOs. The FIFOs are built into the capture and playback paths and are completely transparent to the user and require no programming. The FIFOs are active in MODE1 and MODE2.

The AD1845 maintains a continuous playback stream by requesting data from the host until the FIFO located in the playback path is full. As the FIFO empties, new samples are requested to keep the playback FIFO full. In the event that the FIFO runs out of data and DACZ is reset to “0,” the last valid sample will be continuously played back. If DACZ is “1,” the AD1845 will output a midscale value.

The FIFO located in the capture data path attempts to stay empty by making requests of the host every sample period that it contains valid data. When the host system cannot respond during the same sample period, the capture FIFO starts filling, and avoids a loss of data in the audio data stream.

### Data Bus Drivers

The AD1845 has built-in 8 or 16 mA bus drivers for interfacing to the ISA bus. The drivers reduce the need for the off-chip 74\_245 bus transceiver buffers in many applications. If higher drive capability is required, 24 mA for example, the AD1845 generates the appropriate direction and enable signals. See Figure 1 and refer to the Applications Circuits section of the data sheet.

### Control and Programmed I/O (PIO) Transfers

This simpler mode of transfers is used both for control register accesses and programmed I/O. The 37 control and PIO data registers cannot be accessed via DMA transfers. Playback PIO

# AD1845

is activated when both Playback Enable (PEN) is set and Playback PIO (PPIO) is set. Capture PIO is activated when both Capture Enable (CEN) is set and Capture PIO (CPIO) is set. See Figures 20 and 21 for the detailed timing of the control register/PIO transfers. The  $\overline{RD}$  and  $\overline{WR}$  signals are used to define the actual read and write cycles, respectively. The host holds CS LO during these transfers. The DMA Capture Data Acknowledge ( $\overline{CDAK}$ ) and Playback Data Acknowledge ( $\overline{PDAK}$ ) must be held inactive, i.e., HI.

For read/capture cycles, the AD1845 will place data on the DATA7:0 lines while the host is asserting the read strobe,  $\overline{RD}$ , by holding it LO. For write/playback, the host must place data on the DATA7:0 pins while strobing the  $\overline{WR}$  signal LO. The AD1845 latches the write/playback data on the rising edge of the  $\overline{WR}$  strobe.

When using PIO data transfers, the Status Register must be polled to determine when data should be transferred. Note that the ADC capture data will be ready (CRDY HI) from the previous sample period shortly before the DAC playback data is ready (PRDY HI) for the next sample period. The user should not wait for both ADCs and DACs to become ready before initiating data transfers. Instead, as soon as capture data is ready, it should be read; as soon as the DACs are ready, playback data should be written.

Values written to the XCTL1:0 bits in the Pin Control Register (IXA3:0 = 10) will be reflected in the state of the XCTL1:0 external output pins. This feature allows a simple method for signaling or software control of external logic. Changes in state of the external XCTL pins will occur within one sample period. Because their change is referenced to the internal sample clock, no useful timing diagram can be constructed.

## DIRECT MEMORY ACCESS (DMA) TRANSFERS

The second type of bus cycle supported by the AD1845 are DMA transfers. Both dual channel and single channel DMA operations are supported. To enable Playback DMA transfers, playback enable (PEN) must be set and PPIO cleared. To enable Capture DMA transfers, capture enable (CEN) must be set and CPIO cleared. During DMA transfers, the AD1845 asserts HI the Capture Data Request (CDRQ) or the Playback Data Request (PDRQ) followed by the host's asserting LO the DMA Capture Data Acknowledge ( $\overline{CDAK}$ ) or Playback Data Acknowledge ( $\overline{PDAK}$ ), respectively. The host's asserted

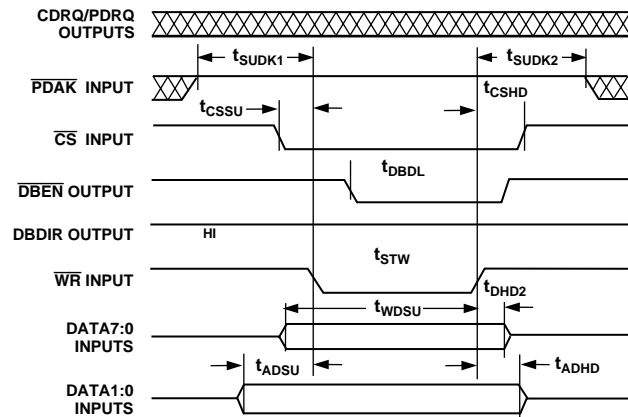

Figure 21. Control Register/PIO Write Cycle

Acknowledge signals cause the AD1845 to perform DMA transfers. The input address lines, ADR1:0, are ignored. Data is transferred between the proper internal sample registers.

The read strobe ( $\overline{RD}$ ) and write strobe ( $\overline{WR}$ ) delimit valid data for DMA transfers. Chip select ( $\overline{CS}$ ) is a “don't care”; its state is ignored by the AD1845.

The AD1845 may assert the Data Request signals, CDRQ and PDRQ, at any time. Once asserted, these signals will remain active HI until the corresponding DMA cycle occurs with the host's Data Acknowledge signals. The Data Request signals will be deasserted after the falling edge of the *final*  $\overline{RD}$  or  $\overline{WR}$  strobe in the transfer of a sample, which typically consists of multiple bytes. See “Data Ordering” above for a definition of “sample.”

DMA transfers may be independently aborted by resetting the Capture Enable (CEN) and/or Playback Enable (PEN) bits in the Interface Configuration Register. The current capture sample transfer will be completed if a capture DMA is terminated. The current playback sample transfer must be completed if a playback DMA is terminated. If CDRQ and/or PDRQ are asserted HI while the host is resetting CEN and/or PEN, the request must be acknowledged. The host must assert  $\overline{CDAK}$  and/or  $\overline{PDAK}$  LO and complete a final sample transfer.

## Single-Channel DMA

Single-Channel DMA mode allows the AD1845 to be used in systems with only a single DMA channel. It is enabled by setting the SDC bit in the Interface Configuration Register. All captures and playbacks take place on the playback channel. Obviously, the AD1845 cannot perform a simultaneous capture and playback in Single-Channel DMA mode.

Playback will occur in Single-Channel DMA mode exactly as it does in Two-Channel mode. Capture, however, is diverted to the playback channel which means that the capture data request occurs on the PDRQ pin and the capture data acknowledge must be received on the  $\overline{PDAK}$  pin. The CDRQ pin will remain inactive LO. Any inputs to  $\overline{CDAK}$  will be ignored.

Playback and capture are distinguished in Single-Channel DMA mode by the state of the playback enable (PEN) or capture enable (CEN) control bits. If both PEN and CEN are set in Single-Channel DMA mode, playback will be presumed.

To avoid confusion of the origin of a request when switching between playback and capture in Single-Channel DMA mode, both CEN and PEN should be disabled and all pending requests serviced before enabling the alternative enable bit.

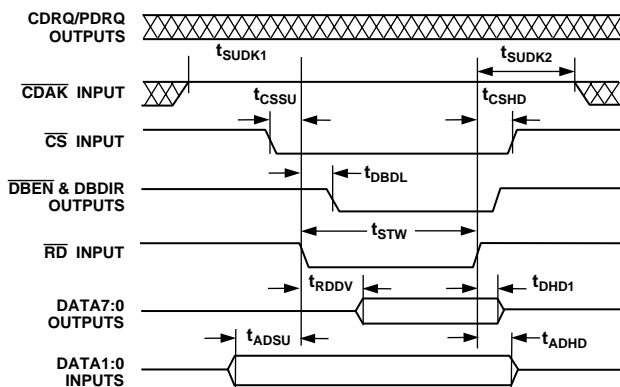

Figure 20. Control Register/PIO Read Cycle

Switching between playback and capture in Single-Channel DMA mode does not require changing the PPIO and CPIO bits or passing through the Mode Change Enable state except for initial setup. For setup, assign zeros to both PPIO and CPIO. This configures both playback and capture for DMA. Following setup, switching between playback and capture can be effected entirely by setting and clearing the PEN and CEN control bits, a technique which avoids having to enter Mode Change Enable.

**Dual-Channel DMA**

The AD1845 is designed to support full duplex DMA operation by allowing simultaneous capture and playback. The Dual-Channel DMA feature enables playback and capture DMA requests and acknowledges to occur on separate DMA channels. Capture and playback are enabled and set for DMA transfers. In addition, Dual-Channel DMA must be set (SDC = 0). It is not necessary to enter MCE (Mode Change Enable) to change PEN and CEN (Playback and Capture Enable).

**DMA Timing**

Below, timing parameters are shown for 8-Bit Mono Sample Read/Capture and Write/Playback DMA transfers in Figures 22 and 23. The same timing parameters apply to multi-byte transfers. The relationship between timing signals is shown in Figures 24 and 25.

The Host Interrupt Pin (INT) will go HI after a sample transfer in which the Current Count Register underflows.

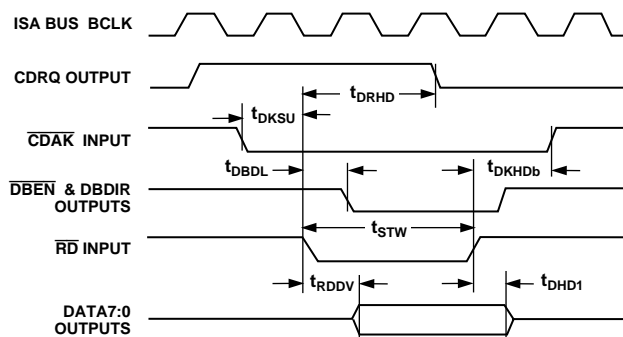

Figure 22. 8-Bit Mono DMA Read/Capture Cycle

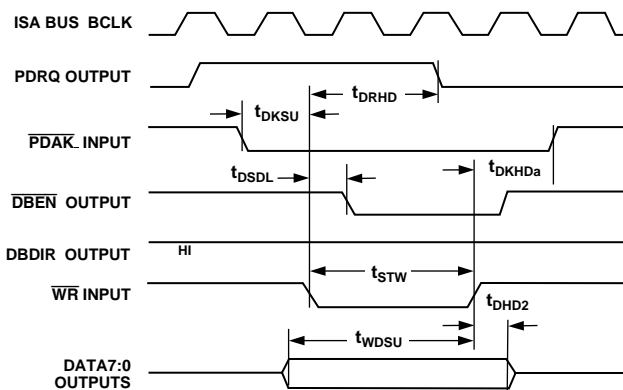

Figure 23. 8-Bit Mono DMA Write/Playback Cycle

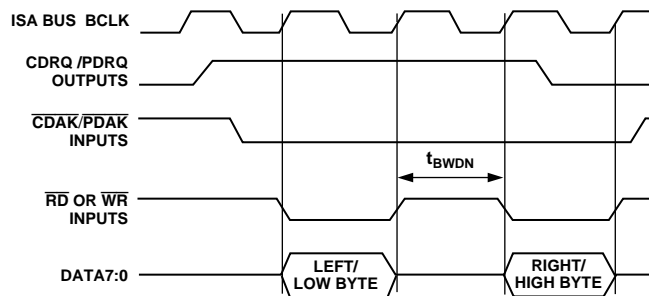

Figure 24. 8-Bit Stereo or 16-Bit Mono DMA Cycle

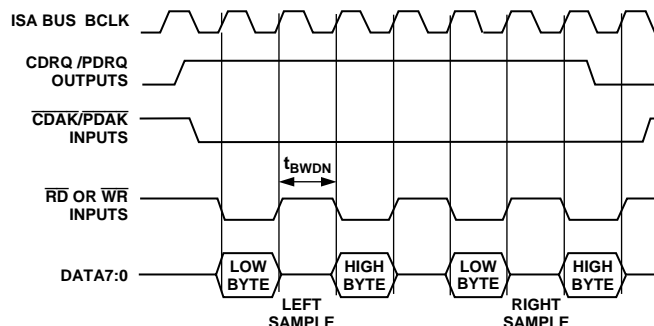

Figure 25. 16-Bit Stereo DMA Interrupt

**DMA Interrupt**

Writing to the internal 16-bit Base Count Register sets up the count value for the number of samples to be transferred. Note that the number of bytes transferred for a given count will be a function of the selected global data format. The internal Current Count Register is updated with the current contents of the Upper and Lower Base Count Registers when a write occurs to the Upper Base Count Register.

The Current Count Register cannot be read by the host. Reading the Base Count Registers will only read back the initialization values written to them.

The Current Count Register decrements by one after every sample transferred. An interrupt event is generated after the Current Count Register is zero and an additional playback sample is transferred. The INT bit in the Status Register always reflects the current internal interrupt state defined above. The external INT pin will only go active HI if the Interrupt Enable (wIEN) bit in the Interface Configuration Register is set. If the IEN bit is zero, the external INT pin will always stay LO, even though the Status Register's INT bit may be set.

# AD1845

## POWER-UP AND RESET

The  $\overline{\text{PWRDWN}}$  and  $\overline{\text{RESET}}$  pin should be held in the active LO state when power is first applied to the AD1845. The AD1845's initialization commences when  $\overline{\text{PWRDWN}}$  and  $\overline{\text{RESET}}$  have both been deasserted (HI). While initializing, the AD1845 ignores all writes and all reads will yield "1000 0000 (80h)." At the conclusion of initialization, all registers will be set to their default values as listed in Figure 5. When CDAK and PDAK are inactive during power-up or reset, the conclusion of the initialization period, after approximately 512 ms, can be detected by polling the index register for some value *other* than "1000 0000 (80h)."

Upon power-up the AD1845 enters the Mode Change Enable (MCE) state. In the default condition, the AD1845 expects to receive a 24.576 MHz input clock source. To change the selection of the current or default input clock source, follow the steps listed below:

- Wait for the AD1845 to initialize.
- Set the MODE2 bit to 1.
- Enter the MCE state, write to the Crystal/Clock Input Frequency Select bits (XFS2:0) to select the desired frequency.
- The AD1845 will now resynchronize its internal states to the new clock. Writes to the AD1845 will be ignored. Poll the index register for some value *other* than "1000 0000 (80h)."
- Clear the MCE bit.

## ADVANCED POWER-DOWN MODES

The AD1845 has eight Advanced Power-Down Modes available at any time. The user can control these power-down modes through hardware by asserting the  $\overline{\text{PWRDWN}}$  and  $\overline{\text{RESET}}$  pins or through software by writing to the Power-Down and the Total Power-Down Control Registers. Figure 26 summarizes the power-down delay, power-up delay, and power dissipation for each power-down mode. A priority listing and description of the power-down modes follows. Note that the hardware controlled Power-Down and Reset modes take precedence over the software controlled power-down states.

## Hardware Controlled States

The hardware power-down states are accessed by bringing the  $\overline{\text{PWRDWN}}$  or  $\overline{\text{RESET}}$  pin LO. Either of these signals place the AD1845 into the maximum power conservation mode. Bringing the  $\overline{\text{PWRDWN}}$  or  $\overline{\text{RESET}}$  pin HI will power-up the codec in approximately 512 ms (see the Power-Up and Reset section of this data sheet).

- *Power-Down:*  $\overline{\text{PWRDWN}}$  immediately puts the AD1845 into its lowest power-down state. The AD1845's parallel interface will not function and all bidirectional signal lines will be in a high-impedance state.
- *Reset:*  $\overline{\text{RESET}}$  powers down the AD1845 gradually to its lowest power-down state. The AD1845 performs a sequenced power-down that eliminates audible effects from the DAC's output. The XTAL1 input must be clocked for the minimum duration of the  $\overline{\text{RESET}}$  pulsewidth. The AD1845's parallel interface will not function and all bidirectional signal lines will be in a high-impedance state. Note: the clock must operate during the software or hardware power-down process.

## Software Controlled States

To enter the Total Power-Down mode requires entering the Mode Change Enable (MCE) state. After entering MCE, the Total Power-Down mode can be accessed by writing a "1" to the TOTPWD bit in the Total Power-Down Register. Exiting the Total Power-Down mode (writing a "0" to the TOTPWD bit in the Total Power-Down Register) will initialize the AD1845 in approximately 512 ms (see the Power-Up and Reset section of this data sheet).

- *Total Power-Down:* In the Total Power-Down mode the ADC, DAC, Mixer, and voltage reference are turned off, but the digital interface remains active awaiting power-up. All ADC and DAC data is flushed including data in the capture and playback FIFOs.

To enter the software controlled power-down states in the Power-Down Control Register, write a "1" to the control bits.

Advanced Power-Down Mode	$\overline{\text{PWRDWN}}$ Pin	$\overline{\text{RESET}}$ Pin	TOTPWD Bit	ADCPWD Bit	DACPWD Bit	MIXPWD Bit	Power-Down Delay*	Power-Up Delay*	Power Dissipation
Operating	HI	HI	0	0	0	0	x	x	600 mW
1. Power-Down	LO	x	x	x	x	x	0 s	512 ms	10 mW
2. Reset	HI	LO	x	x	x	x	3 ms	512 ms	10 mW
3. Total Power-Down	HI	HI	1	x	x	x	3 ms	512 ms	150 mW
4. Standby	HI	HI	0	1	x	1	1/F <sub>S</sub>	1/F <sub>S</sub>	180 mW
5. Mixer Power-Down	HI	HI	0	0	x	1	1/F <sub>S</sub>	1/F <sub>S</sub>	350 mW
6. Mixer Only	HI	HI	0	1	1	0	1/F <sub>S</sub>	1/F <sub>S</sub>	260 mW
7. ADC Power-Down	HI	HI	0	1	0	0	1/F <sub>S</sub>	1/F <sub>S</sub>	400 mW
8. DAC Power-Down	HI	HI	0	0	1	0	1/F <sub>S</sub>	1/F <sub>S</sub>	425 mW

"x" = Don't Care

\*Values shown are derived using a 24.576 MHz input clock source.

All values are proportional to the input clock source.

Figure 26. Advanced Power-Down Mode Summary

The AD1845 performs a sequenced power-down that eliminates audible effects from the DAC's output, and saves the codec's internal operating state. Clearing the bits (writing a "0" to the control bits) returns the AD1845 from the power-down state and begins the initialization sequence. The AD1845 exits the power-down mode within 1 sample period. However, an additional 128 sample periods are required to unmute the outputs and restore the internal settings to the pre-Power-Down operating state.

- *Standby*: Entering the Standby mode places the ADC, DAC and the Mixer into a low power state, and forces all outputs to be muted. Standby turns off all internal digital and analog circuitry with the exception of the digital interface and the voltage reference. All ADC and DAC data is flushed including data in the capture and playback FIFOs.
- *Mixer Power-Down*: Entering the Mixer Power-Down mode, causes both the mixer and the DAC circuitry to be turned off. All DAC data is flushed including data in the playback FIFO. In this mode the mixer is off and the AD1845 is muted, but the ADC remains functional.
- *Mixer Only*: The Mixer Only mode is initiated by powering down both the ADC and DAC, leaving the analog mixer and the digital interface active. MIC, LINE, AUX1, AUX2, and M\_IN can be mixed in the analog domain on the AD1845 outputs. All ADC and DAC data is flushed including data in the capture and playback FIFOs.
- *ADC Power-Down*: Entering the ADC Power-Down mode, causes the ADC digital and analog engines to be turned off. All ADC data is flushed including data in the capture FIFO and the AD1845 is rendered deaf. The input programmable gain amplifier (PGA) is also shut down. The DAC and mixer remain active allowing the AD1845 to continue to playback and mix samples.
- *DAC Power-Down*: Entering the DAC Power-Down mode suspends the DAC digital and analog engines, and all DAC data is flushed including data in the playback FIFO. However, the mixer and ADC are functional allowing the AD1845 to continue to capture and mix samples.

#### AUTOCALIBRATION

The AD1845 calibrates the ADCs and DACs for greater accuracy by minimizing dc offsets. Upon power-up or after  $\overline{\text{RESET}}$ , the AD1845 automatically performs an autocalibration after the first return from the Mode Change Enable state, regardless of the state of the ACAL bit. Autocalibration can be forced when the AD1845 returns from the Mode Change Enable state and the ACAL bit in the Interface Configuration register has been set. If the ACAL bit is not set, the RAM normally containing ADC and DAC offset compensations will be saved, retaining the offsets of the most recent autocalibration.

The completion of autocalibration can be determined by polling the Autocalibrate-In-Progress (ACI) bit in the Test and Initialization Register, which will be set during autocalibration. Transfers enabled during autocalibration do not begin until the completion of autocalibration.

The following summarizes the procedure for autocalibration:

- Set the Mode Change Enable (MCE) bit.
- Set the Autocalibration (ACAL) bit.

- Clear the Mode Change Enable (MCE) bit.
- The Autocalibrate-In-Progress (ACI) bit will remain HI for 384 sample periods. Poll the ACI bit until it transitions from HI to LO.
- Set desired gain/attenuation/mute and digital mix values.

During the autocalibration sequence, data output from the ADCs is meaningless. Inputs to the DACs are ignored. Even if the user specified the muting of all analog outputs, near the end of the autocalibration sequence, dc analog outputs very close to  $V_{\text{REF}}$  will be produced at the line output.

#### CHANGING SAMPLE RATES

In MODE1 the AD1845 can change sample rates by entering the Mode Change Enable state or writing directly to the Clock and Data Format Register. In MODE2, the AD1845 changes sample rates by writing directly to the Upper and Lower Frequency Select Register. Please refer to the following examples for changing the sample rate.

To change the selection of the current sample rate by entering the Mode Change Enable state requires the sequence which is summarized as follows (this is the same sequence used by the AD1848, AD1846, CS4248, and CS4231):

- Set the Mode Change Enable (MCE) bit.
- In a single write cycle, change the Clock Frequency Divide Select (CFS2:0) and/or the Clock Source Select (CSS).
- The AD1845 now needs to resynchronize its internal states to the new clock. Writes to the AD1845 will be ignored. Reads will produce "1000 0000 (80h)" until the resynchronization is complete. Poll the Index Register until something other than this value is returned.
- Clear the Mode Change Enable (MCE) bit.
- If ACAL is set, follow the procedure described in "Autocalibration" above.
- Wait 128 sample cycles or poll the ACI bit until it transitions LO.
- Set to desired gain/attenuation values, and unmute DAC outputs (if muted).

Alternatively, the AD1845 can be programmed to change the sample rate selection "on the fly" without entering the Mode Change Enable Sequence. The following sequence applies to the AD1845 operating in MODE1 or MODE2.

- In a single write cycle, change the Clock Frequency Divide Select (CFS2:0) and/or the Clock Source Select (CSS). For compatibility reasons, the AD1845 will send out "1000 0000 (80h)" for approximately 200  $\mu\text{s}$ . Even this short wait can be disabled by setting the INITD bit. When the INITD bit is set, the AD1845 is ready immediately after changing the sample rate using CFS and CSS.
- The AD1845 now needs to resynchronize its internal states to the new clock. Writes to the AD1845 will be ignored. Reads will produce "1000 0000 (80h)" until the resynchronization is complete. Poll the Index Register until something other than this value is returned.
- Set to desired gain/attenuation values, and unmute DAC outputs (if muted).

# AD1845

In the Expanded Mode, MODE2, the AD1845 can be programmed to change the sample rate selection in 1 Hz increments “on the fly” and without entering the Mode Change Enable Sequence. The following sequence applies to the AD1845 in MODE2 only:

- Enable the Frequency Select Register by setting FREN to 1.
- Change the Lower and Upper Frequency Select Register, FU7:0 and FL7:0.

## APPLICATIONS CIRCUITS

The AD1845 Stereo Codec has been designed to require a minimum of external circuitry. The recommended circuits are shown in Figures 27 through 35.

See Figure 1 for an illustration of the connection between the AD1845 SoundPort Codec and the Industry Standard Architecture (ISA) computer bus, also known as the “PC-AT bus.” Note that the 74\_245 transceiver receives its enable and direction signals directly from the Codec. Analog Devices recommends using the “slowest” 74\_245 adequately fast to meet all AD1845 and computer bus timing and drive requirements. So doing will minimize switching transients of the 74\_245. This in turn will minimize the digital feed through effects of the transceiver when driving the AD1845, which can cause the audio noise floor to rise. In most applications, the 74\_245 can be omitted and the AD1845 connected directly ISA bus taking advantage of the AD1845’s built-in 16 mA drivers.

Industry-standard compact disc “line-levels” are 2 V rms centered around analog ground. (For other audio equipment, “line level” is much more loosely defined.) The AD1845 SoundPort is a +5 V only powered device. Line level voltage swings for the AD1845 are defined to be 1 V rms for a sine wave ADC input and user selectable 0.707 V rms or 1 V rms for a sine wave DAC output. Thus, 2 V rms input analog signals must be attenuated and either centered around the reference voltage intermediate between 0 V and +5 V or ac coupled. The V<sub>REF</sub> pin will be at this intermediate voltage, nominally 2.25 V. It has limited drive but can be used as a voltage datum to an op amp input. Note, however, that dc-coupled inputs are not recommended, as they provide no performance benefits with the AD1845 architecture. Furthermore, dc offset differences between multiple dc-coupled inputs create the potential for “clicks” when changing the input mixer selection.

A circuit for 2 V rms mono, line-level inputs and auxiliaries is shown in Figure 27 and Figure 28. Note that this is a divide-by-two resistive dividers considering the codec input impedance. The input resistor and 560 pF (1000 pF) capacitor provides the single-pole of antialias filtering required for the ADCs. If line-level inputs are already at the 1 V rms levels expected by the AD1845, the resistors in parallel with the 560 pF (1000 pF) capacitors can be omitted. If the application does not route the AUX2 inputs to the ADCs, then no antialias filtering is required (only the 1 μF ac coupling capacitor).

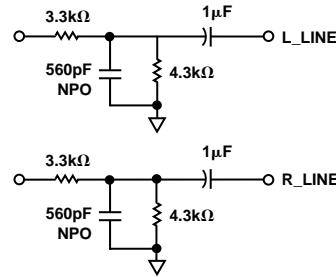

Figure 27. 2 V rms Line-Level Input Circuit for LINE Inputs

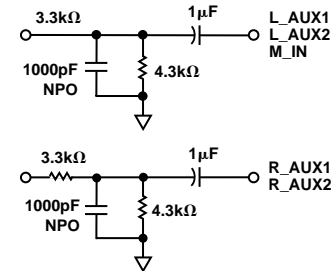

Figure 28. 2 V rms Line-Level Input Circuit for M\_IN and AUX Inputs

The AD1845 codec contains an optional +20 dB gain block to accommodate condenser microphones. Particular system requirements will depend upon the characteristics of the intended microphone. Figure 29 illustrates one example of how an electret condenser mike requiring phantom power could be connected to the AD1845. V<sub>REF</sub> is shown buffered by an op amp; a transistor like a 2N4124 will also work fine for this purpose. Note that if a battery-powered microphone is used, the buffer and R<sub>2</sub>s are not needed. The values of R<sub>1</sub>, R<sub>2</sub>, and C should be chosen in light of the mic characteristics and intended gain. Typical values for these might be R<sub>1</sub> = 20 kΩ, R<sub>2</sub> = 2 kΩ, and C = 220 pF.

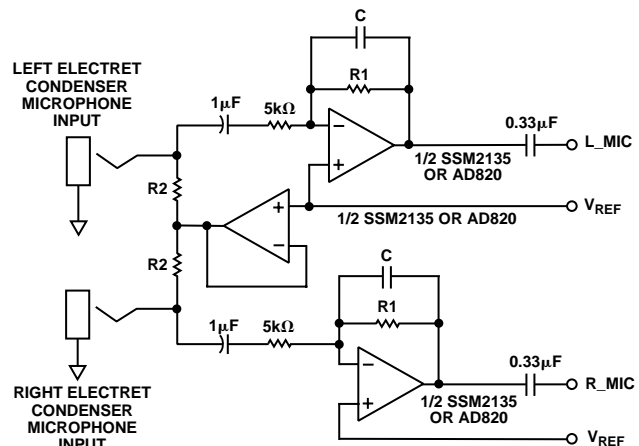

Figure 29. “Phantom-Powered” Microphone Input Circuit

Figure 30 shows ac-coupled line outputs. The resistors are used to center the output signals around analog ground. If dc-coupling is desired,  $V_{REF}$  could be used with op amps as mentioned above, if desired.

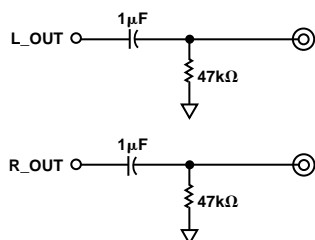

Figure 30. Line Output Connections

A circuit for headphone drive is illustrated in Figure 31. Drive is supplied by +5 V operational amps. The circuit shown ac couples the headphones to the line output.

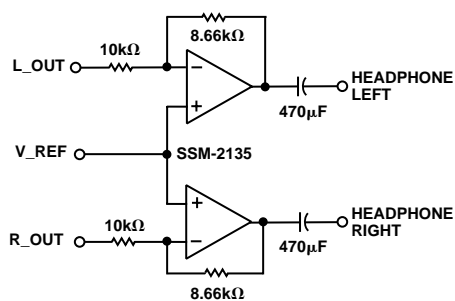

Figure 31. Headphone Drive Connections

Figure 32 illustrates reference bypassing.  $V_{REF\_F}$  should only be connected to its bypass capacitors.

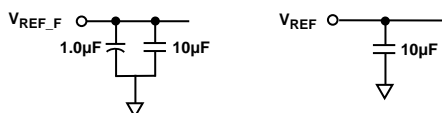

Figure 32. Voltage Reference Bypassing

Figure 33 illustrates signal-path filtering capacitors,  $L\_FILT$  and  $R\_FILT$ . The AD1845 must use 1.0  $\mu F$  capacitors; the AD1845 will not perform properly with 1000 pF capacitors. The 1.0  $\mu F$  capacitors required by the AD1845 can be of any type.

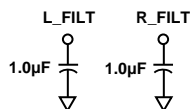

Figure 33. External Filter Capacitor Connections

The crystal shown in the crystal connection circuitry of Figure 34 should be 24.576 MHz, fundamental-mode and parallel-tuned. Note that using the exact data sheet frequencies is not required and that external clock sources can be used to overdrive the AD1845's internal oscillators. (See the description of the CFS2:0 control bits above.) If using an external clock source, apply it to the crystal input pins while leaving the crystal output pins unconnected. Attention should be paid to providing low jitter external input clocks.

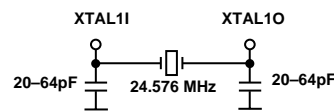

Figure 34. Crystal Connections

Note: XTAL2I and XTAL2O, are not used in the AD1845.

Analog Devices also recommends a pull-down resistor for  $PWRDWN$ .

Good, standard engineering practices should be applied for power-supply decoupling. Decoupling capacitors should be placed as close as possible to package pins. If a separate analog power supply is not available, we recommend the circuit shown in Figure 35 for using a single +5 V supply. Ferrite beads suffice for the inductors shown (typically 600  $\Omega$  at 100 MHz). This circuitry should be as close to the supply pins as is practical.

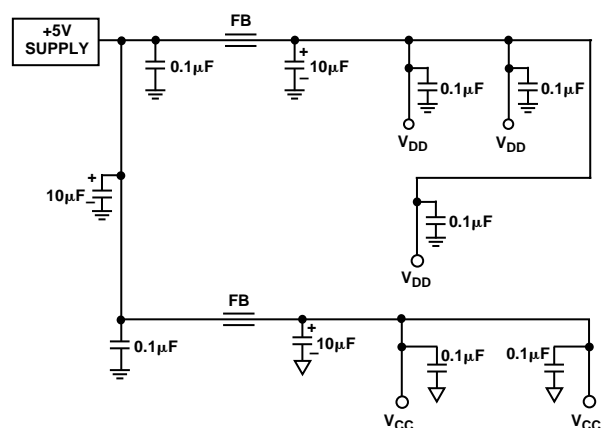

Figure 35. Recommended Power Supply Bypassing

## GROUNDING AND LAYOUT

Analog Devices recommends a split ground plane as shown in Figure 36. The analog plane and the digital plane are connected directly under the AD1845. Splitting the ground plane directly under the SoundPort Codec is optimal because analog pins will be located above the analog ground plane and digital pins will be located directly above the digital ground plane for the best isolation.

Other schemes may also yield satisfactory results. If the split ground plane recommended here is not possible, the AD1845 should be entirely over the analog ground plane with the optional 74\_245 transceiver over the digital plane.

Some manufacturers of compatible devices differentiate between digital supply pins used to power internal logic and digital supply pins used to power the ISA bus driver. Their recommended layout suggests connecting the internal logic supply pins to the analog supply. A potential problem can occur if the layout connects digital supply pins to the analog supply. Connecting some of the digital supply pins to one supply and some of the digital supply pins to a different supply can create an internal short between the two different +5 V supplies.

# AD1845

Analog Devices recommends that all digital pins be driven from the same supply. A common technique to achieve maximum performance is to use a +5 V regulator to power the analog side of the codec from the PC's +12 V supply line, while the standard PC +5 V supply line powers the entire digital side of the codec. The separate supplies provide noise isolation for the analog side of the codec, and maximize performance of the AD1845.

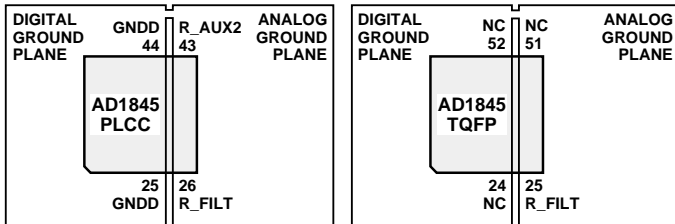

Figure 36. Recommended Ground Plane

## COMPATIBILITY WITH CS4231

1. The CS4231 requires a 1000 pF NPO type capacitor on Pins 26 and 31. The AD1845 requires a 1  $\mu$ F capacitor on filter Pins 26 and 31. To achieve compatibility with the AD1845, use pad spacing that will accommodate either 1000 pF NPO capacitors for the CS4231 and the CS4248 or the 1  $\mu$ F capacitors for the AD1845.
2. The AD1845 requires the input antialiasing filters for the ADCs (refer to Figures 27 and 28). The CS4231 can use the same filters with no degradation in performance. For compatibility it is suggested that the filters be added.
3. The CS4231 does not require the power pins ( $V_{DD}$ ) 24, 45, and 54, or the ground pins (GNDD) 25, and 44. It is suggested that the appropriate power/ground pin connections be made. This will not affect the performance of the CS4231.
4. The CS4231 does not provide software programmable power-down modes.
5. The CS4231 does not have the ability to mix the MIC input with the DAC output.
6. The CS4231 does not contain a Variable Sample Frequency Generator and cannot change sample rates "on the fly." The CS4231 and CS4248 require entering MCE to change the sample rate. The AD1845 can change the sample rate without entering MCE. The AD1845's 50,000 selectable sample rates are not available on the CS4231. The Variable Sample Frequency Generator reduces clicks and pops encountered in many game applications.
7. The CS4231 requires two crystal inputs, 24.575 MHz and 16.9344 MHz. The AD1845 requires only one input of 24.576 MHz or can be driven from OSC or other external clocks.
8. The CS4231 does not contain the INITD bit.
9. The CS4231 minimum  $R_{IN} = 20$  k $\Omega$ . The AD1845 minimum input resistance is 10 k $\Omega$ .
10. The AD1845 does not include hardware for compressing and decompressing ADPCM data. Analog Devices offers Windows based software applets for using ADPCM formats with the AD1845.

FREQUENCY RESPONSE PLOTS

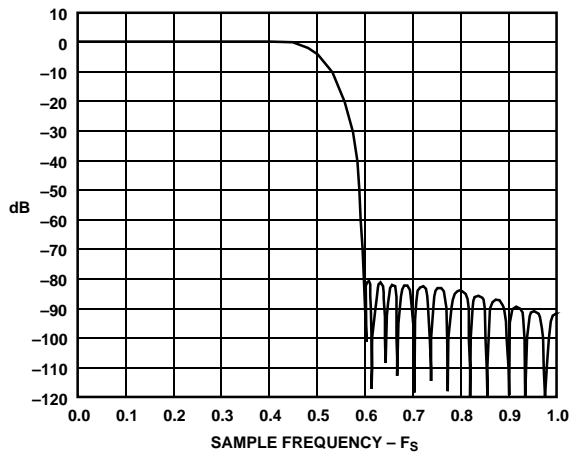

Figure 37. Analog-to-Digital Frequency Response to  $F_s$  (Full-Scale Line-Level Inputs, 0 dB)

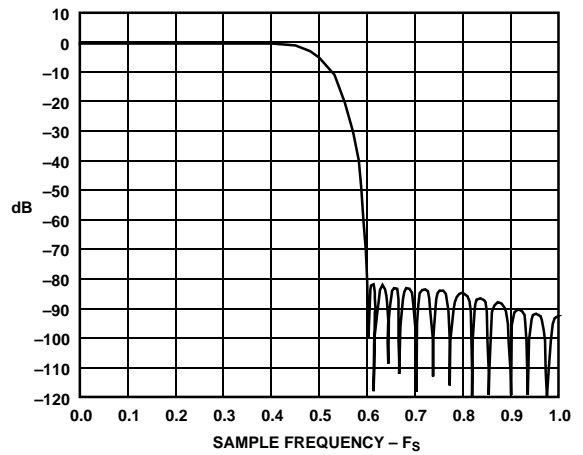

Figure 39. Digital-to-Analog Frequency Response to  $F_s$  (Full-Scale Inputs, 0 dB)

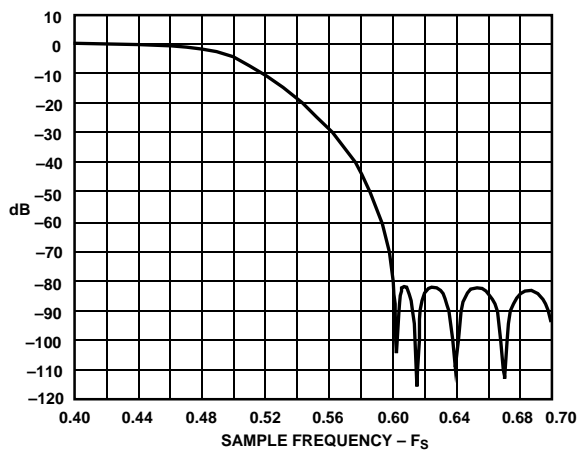

Figure 38. Analog-to-Digital Frequency Response —Transition Band (Full-Scale Line-Level Inputs, 0 dB)

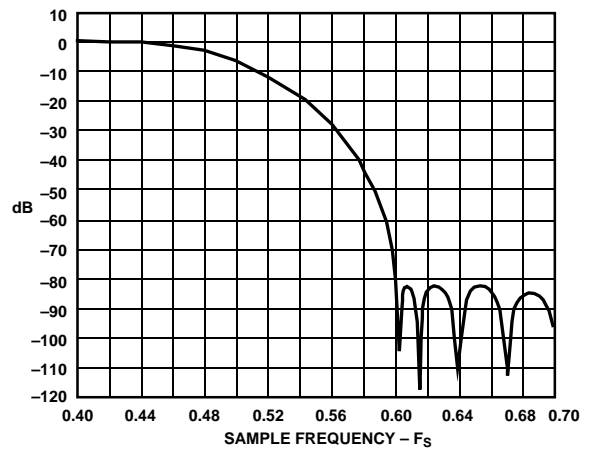

Figure 40. Digital-to-Analog Frequency Response —Transition Band (Full-Scale Inputs, 0 dB)

# AD1845

## APPENDIX

### EXTENDED TEMPERATURE SPECIFICATIONS

#### Test Conditions

The AD1845 has been tested over the industrial temperature range. The typical values represent the limits that change with temperature. All other limits remain unchanged.

Temperature	-40°C to +85°C	DAC Test Conditions
Digital Supply ( $V_{DD}$ )	5.0 V	Calibrated
Analog Supply ( $V_{CC}$ )	5.0 V	0 dB Attenuation
Sample Rate ( $F_S$ )	48 kHz	16-Bit Linear Mode
Input Signal	1008 Hz	Mute Off, OL = 0
Analog Output Passband	20 Hz to 20 kHz	
$V_{IH}$	2.0 V	ADC Input Conditions
$V_{IL}$	0.8 V	Calibrated
$V_{OH}$	2.4 V	0 dB Gain
$V_{OL}$	0.4 V	-1.0 dB Relative to Full Scale
		Line Input
		16-Bit Linear Mode

### PROGRAMMABLE GAIN AMPLIFIER—ADC

Parameter	Min	Typ	Max	Units
Step Size (All Steps Tested) (0 dB to 22.5 dB)		1.75		dB
PGA Gain Range Span		22.83		dB

### AUXILIARY, LINE, MONO, AND MICROPHONE INPUT ANALOG GAIN/AMPLIFIERS/ATTENUATORS

Parameter	Min	Typ	Max	Units
Step Size AUX1, AUX2, LINE, MIC (All Steps Tested): (+12 dB to -34.5 dB, Referenced to DAC Full Scale)		1.5		dB
Step Size: M_IN (All Steps Tested) (0 dB to -45 dB)		3.0		dB
Input Gain/Attenuation Range: AUX1, AUX2, LINE, MIC		46.2		dB
Input Gain/Attenuation Range: M_IN		43.5		dB

### ANALOG-TO-DIGITAL CONVERTERS

Parameter	Min	Typ	Max	Units
Dynamic Range (-60 dB Input THD+N Referenced to Full Scale, A-Weighted)		-81		dB
THD+N (Referenced to Full Scale)		-76		dB

### DIGITAL-TO -ANALOG CONVERTERS

Parameter	Min	Typ	Max	Units
Dynamic Range (-60 dB Input THD+N Referenced to Full Scale, A-Weighted)		-82		dB
THD+N (Referenced to Full Scale)		-78		dB

### DAC ATTENUATOR

Parameter	Min	Typ	Max	Units
Step Size (0 dB to -22.5 dB)		-1.5		dB

### ANALOG OUTPUT

Parameter	Min	Typ	Max	Units
$V_{REF}$		2.36		V

**TABLE OF CONTENTS**

PRODUCT OVERVIEW	1
Expanded Mode (MODE2)	9
SPECIFICATIONS	2
ORDERING GUIDE	5
PIN DESIGNATIONS	6
PIN FUNCTION DESCRIPTIONS	7
FUNCTIONAL DESCRIPTION	10
Analog Inputs	10
Analog Mixing	10
Analog-to-Digital Datapath	10
Digital-to-Analog Datapath	10
Digital Mixing	10
Analog Outputs	10
Digital Data Types	10
Timer Registers	11
Interrupts	11
Power Supplies and Voltage Reference	11
Clocks and Sample Rates	11
CONTROL REGISTERS	11
Control Register Architecture	11
Direct Control Register Definitions	14
Index Address Register (ADR1:0 = 0)	14
Indexed Data Register (ADR1:0 = 1)	14
Status Register (ADR1:0 = 2)	15
PIO Data Registers (ADR1:0 = 3)	16
Indirect Control Register Definitions	16
Left Input Control (IXA3:0 = 0)	16
Right Input Control (IXA3:0 = 1)	16
Left Aux #1 Input Control (IXA3:0 = 2)	17
Right Aux #1 Input Control (IXA3:0 = 3)	17
Left Aux #2 Input Control (IXA3:0 = 4)	17
Right Aux #2 Input Control (IXA3:0 = 5)	17
Left DAC Control (IXA3:0 = 6)	18
Right DAC Control (IXA3:0 = 7)	18
Clock and Data Format (IXA3:0 = 8)	19
Interface Configuration (IXA3:0 = 9)	20
Pin Control (IXA3:0 = 10)	20
Test and Initialization (IXA3:0 = 11)	21
Miscellaneous Control (IXA3:0 = 12)	21
Digital Mix/Attenuation Control (IXA3:0 = 13)	22
DMA Playback Base Count	22
Upper Base Count (IXA3:0 = 14)	22
Lower Base Count (IXA3:0 = 15)	23
Alternate Feature Enable /Left MIC Input Control (IXA3:0 = 16)	23
MIC Mix Enable/Right MIC Input Control (IXA3:0 = 17)	23
Left Line Gain, Attenuate, Mute, Mix (IXA3:0 = 18)	23
Right Line Gain, Attenuate, Mute, Mix (IXA3:0 = 19)	24
Lower Timer Bits (IXA3:0 = 20)	24
Upper Timer Bits (IXA3:0 = 21)	25
Upper Frequency Select (IXA3:0 = 22)	25
Lower Frequency Select (IXA3:0 = 23)	25
Capture Playback Timer (IXA3:0 = 24)	25
Revision ID (IXA3:0 = 25)	26
Mono Control (IXA3:0 = 26)	26
Power-Down Control (IXA3:0 = 27)	27
Capture Data Format Control (IXA3:0 = 28)	27
Crystal, Clock Select/Total Power-Down (IXA3:0 = 29)	27
Capture Upper Base Count (IXA3:0 = 30)	28
Capture Lower Base Count (IXA3:0 = 31)	28
DATA AND CONTROL TRANSFERS	29
Data Ordering	29
FIFO	29
Data Bus Drivers	29

Control and Programmed I/O (PIO) Transfers	29
DIRECT MEMORY ACCESS (DMA) TRANSFERS	30
Single-Channel DMA	30
Dual-Channel DMA	31
DMA Timing	31
DMA Interrupt	31
POWER-UP AND RESET	32
ADVANCED POWER-DOWN MODES	32
AUTOCALIBRATION	33
CHANGING SAMPLE RATES	33
APPLICATIONS CIRCUITS	34
GROUNDING AND LAYOUT	35
COMPATIBILITY WITH CS4231	36
FREQUENCY RESPONSE PLOTS	37
APPENDIX—EXTENDED TEMPERATURE SPECIFICATIONS	38
PACKAGE OUTLINE DIMENSIONS	40

**FIGURES TABLE OF CONTENTS**

1. Interface to ISA Bus	9
2. $\mu$ -Law or A-Law Expansion	11
3. $\mu$ -Law or A-Law Compression	11
4. Direct Register Map	11
5. Indirect Register Map and Reset/Default States	12
6. Register Summary	13
7. Mix Gain Level Setting: DAC	18
8. MODE1 Audio Sample Frequency Select	19
9. Digital Audio Data Type	19
10. Mix Gain Level Setting: AUX1, AUX2, MIC, LINE	24
11. Mono Attenuation	26
12. Capture Audio Data Type	27
13. Input Frequency Selection	28
14. 8-Bit Mono Data Stream Sequencing	29
15. 8-Bit Stereo Data Stream Sequencing	29
16. 16-Bit Mono Data Stream Sequencing, Little Endian	29
17. 16-Bit Stereo Data Stream Sequencing, Little Endian	29
18. 16-Bit Mono Data Stream Sequencing, Big Endian	29
19. 16-Bit Stereo Data Stream Sequencing, Big Endian	29
20. Control Register/PIO Read Cycle	30
21. Control Register/PIO Write Cycle	30
22. 8-Bit Mono DMA Read/Capture Cycle	31
23. 8-Bit Mono DMA Write/Playback Cycle	31
24. 8-Bit Stereo or 16-Bit Mono DMA Cycle	31
25. 16-Bit Stereo DMA Interrupt	31
26. Advanced Power-Down Mode Summary	32
27. 2 V rms Line-Level Input Circuit for LINE Inputs	34
28. 2 V rms Line-Level Input Circuit for M_IN and AUX Inputs	34
29. "Phantom Powered" Microphone Input Circuit	34
30. Line Output Connections	35
31. Headphone Drive Connections	35
32. Voltage Reference Bypassing	35
33. External Filter Capacitor Connections	35
34. Crystal Connections	35
35. Recommended Power Supply Bypassing	35
36. Recommended Ground Plane	36
37. Analog-to-Digital Frequency Response to $F_S$ (Full-Scale Line-Level Inputs, 0 dB)	37
38. Analog-to-Digital Frequency Response—Transition Band (Full-Scale Line-Level Inputs, 0 dB)	37
39. Digital-to-Analog Frequency Response to $F_S$ (Full-Scale Inputs, 0 dB)	37
40. Digital-to-Analog Frequency Response—Transition Band (Full-Scale Inputs, 0 dB)	37

**OUTLINE DIMENSIONS**

Dimensions shown in inches and (mm).

**68-Lead Plastic Leaded Chip Carrier  
(P-68A)**

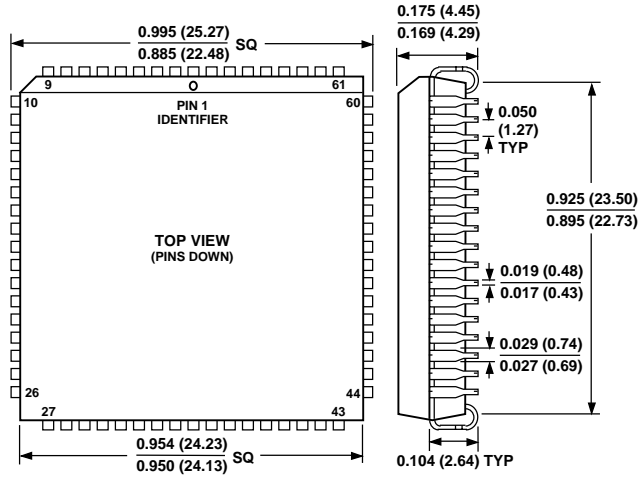

**100-Lead Thin Quad Flatpack  
(ST-100)**

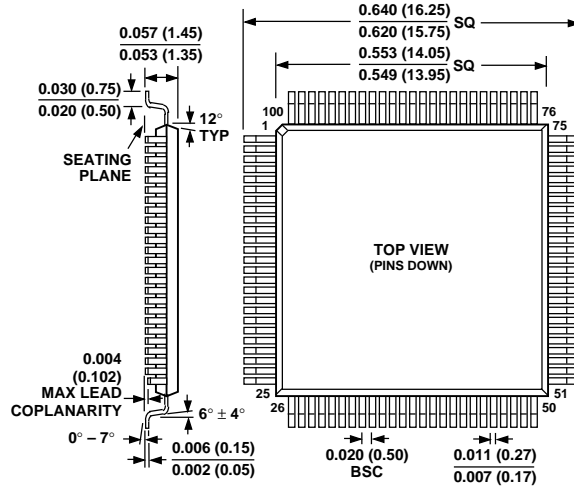



LittleDiode supplies new, hard to find or obsolete electronic components and semiconductors all over the world.

With over two million different components listed you are sure to find the part you need.

Feel free to visit us today at our online store:

[LittleDiode.com](http://LittleDiode.com)

Looking forward to providing you with the best possible service.