

### FEATURES

- Autocalibrating
- 0.002% THD
- 90 dB S/(N+D)
- 1 MHz Full Power Bandwidth
- On-Chip Sample & Hold Function
- 2× Oversampling for Audio Applications
- 16-Pin DIP Package
- Serial Twos Complement Output Format
- Low Input Capacitance—typ 50 pF
- AGND Sense for Improved Noise Immunity

### PRODUCT DESCRIPTION

The AD1876 is a 16-bit serial output sampling A/D converter which uses a switched capacitor/charge redistribution architecture to achieve a 100 kSPS conversion rate (10  $\mu$ s total conversion time). Overall performance is optimized by digitally correcting internal nonlinearities through on-chip autocalibration.

The circuitry of the AD1876 is partitioned onto two monolithic chips, a digital control chip fabricated with Analog Devices' DSP CMOS process and an analog ADC chip fabricated with the BiMOS II process. Both chips are contained in a single package.

The serial output interface requires an external clock and sample command signal. The output data rate may be as high as 2.08 MHz, and is controlled by the external clock. The twos complement format of the output data is MSB first and is directly compatible with the NPC SM5805 digital decimation filter used in consumer audio products. The AD1876 is also compatible with a variety of DSP processors.

The AD1876 is packaged in a space saving 16-pin plastic DIP and operates from +5 V and  $\pm 12$  V supplies; typical power consumption is 235 mW. The digital supply ( $V_{DD}$ ) is isolated from the linear supplies ( $V_{EE}$  and  $V_{CC}$ ) for reduced digital crosstalk. Separate analog and digital grounds are also provided.

### FUNCTIONAL BLOCK DIAGRAM

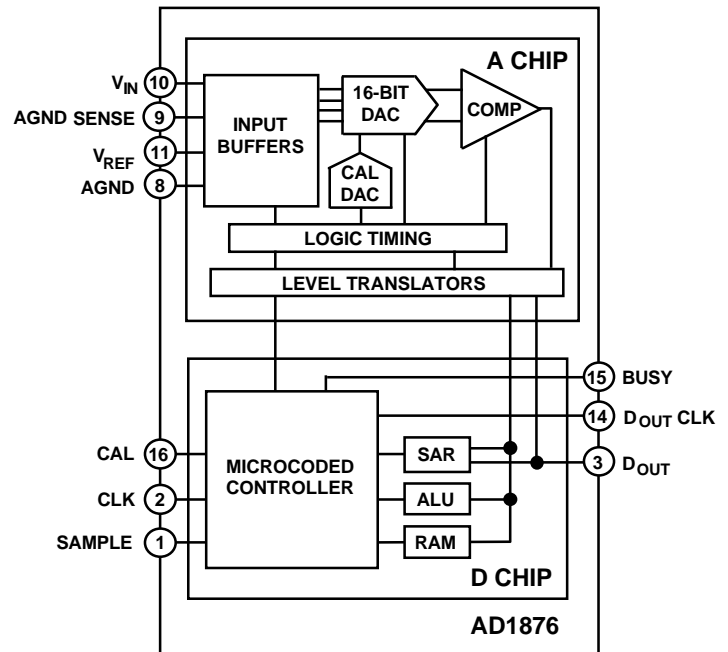

### REV. A

Information furnished by Analog Devices is believed to be accurate and reliable. However, no responsibility is assumed by Analog Devices for its use, nor for any infringements of patents or other rights of third parties which may result from its use. No license is granted by implication or otherwise under any patent or patent rights of Analog Devices.

# AD1876–SPECIFICATIONS ( $T_{MIN}$ to $T_{MAX}$ , $V_{CC} = +12\text{ V} \pm 5\%$ , $V_{EE} = -12\text{ V} \pm 5\%$ , $V_{DD} = +5\text{ V} \pm 10\%$ )<sup>1</sup>

Parameter	AD1876J			Units
	Min	Typ	Max	
TEMPERATURE RANGE	0		70	°C
TOTAL HARMONIC DISTORTION (THD) <sup>2</sup>				
-0.05 dB Input		-95	<b>-88</b>	dB
-20 dB Input		0.002	<b>0.004</b>	%
-60 dB Input		-78		dB
		0.01		%
		-40		dB
		1.0		%
D-RANGE, -60 dB, A-WEIGHTED		92		dB
SIGNAL-TO-NOISE AND DISTORTION (S/(N+D)) RATIO <sup>3</sup>				
-0.05 dB Input, A-Weighted	<b>83</b>	92		dB
-0.05 dB Input, 48 kHz Bandwidth		90		dB
-20 dB Input, A-Weighted		73		dB
-20 dB Input, 48 kHz Bandwidth		70		dB
-60 dB Input, A-Weighted		34		dB
-60 dB Input, 48 kHz Bandwidth		31		dB
PEAK SPURIOUS OR PEAK HARMONIC COMPONENT		-99	<b>-89</b>	dB
INTERMODULATION DISTORTION (IMD) <sup>4</sup>				
2nd Order Products		-102		dB
3rd Order Products		-98		dB
FULL POWER BANDWIDTH		1		MHz
VOLTAGE REFERENCE INPUT RANGE <sup>5</sup> ( $V_{REF}$ )	3	<b>5</b>	10.0	V
ANALOG INPUT <sup>6</sup>				
Input Range ( $V_{IN}$ )			$\pm V_{REF}$	V
Input Impedance		*		
Input Capacitance During Sample		50*		pF
Aperture Delay		6		ns
Aperture Jitter		100		ps
POWER SUPPLIES				
Operating Current				
$I_{CC}$		9	12	mA
$I_{EE}$		9	12	mA
$I_{DD}$		3	12	mA
Power Consumption		235	350	mW

## NOTES

<sup>1</sup> $V_{REF} = 5.00\text{ V}$ ; conversion rate = 96 kSPS;  $f_{IN} = 1.06\text{ kHz}$ ;  $V_{IN} = -0.05\text{ dB}$  unless otherwise noted. All measurements referred to a 0 dB (10 V p-p) input signal.

Values are post calibration.

<sup>2</sup>Includes first 19 harmonics.

<sup>3</sup>Minimum value of S/(N+D) corresponds to 5.0 V reference; typical values of S/(N+D) correspond to 10.0 V reference.

<sup>4</sup> $f_s = 1008\text{ Hz}$ ;  $f_b = 1055\text{ Hz}$ . See Definition of Specifications section and Figure 14.

<sup>5</sup>See Applications section for recommended voltage reference circuit and Figure 11 for performance with other reference voltage values.

<sup>6</sup>See Applications section for recommended input buffer circuit.

\*For explanation of input characteristics, see "Analog Input" section.

Specifications subject to change without notice.

Specifications shown in **boldface** are tested on all devices at final electrical test at worst case temperature. Results from those tests are used to calculate outgoing quality levels. All min and max specifications are guaranteed, although only those shown in boldface are tested.

## ORDERING GUIDE

Model	Temperature Range	THD dB	Package Description	Package Option*
AD1876JN	0°C to +70°C	-95	Plastic 16-Pin DIP	N-16

\*N = Narrow Plastic DIP.

## DIGITAL SPECIFICATIONS ( $T_{MIN}$ to $T_{MAX}$ , $V_{CC} = +12\text{ V} \pm 5\%$ , $V_{EE} = -12\text{ V} \pm 5\%$ , $V_{DD} = +5\text{ V} \pm 10\%$ )

Parameter	Test Conditions	Min	Typ	Max	Units
<b>LOGIC INPUTS</b>					
$V_{IH}$ High Level Input Voltage		<b>2.4</b>			V
$V_{IL}$ Low Level Input Voltage		-0.3		<b>0.8</b>	V
$I_{IH}$ High Level Input Current	$V_{IH} = V_{DD}$	<b>-10</b>		<b>+10</b>	$\mu\text{A}$
$I_{IL}$ Low Level Input Current	$V_{IL} = 0\text{ V}$	<b>-10</b>		<b>+10</b>	$\mu\text{A}$
$C_{IN}$ Input Capacitance				10	pF
<b>LOGIC OUTPUTS</b>					
$V_{OH}$ High Level Output Voltage	$I_{OH} = 0.1\text{ mA}$	$V_{DD} - 1\text{ V}$			V
	$I_{OH} = 0.5\text{ mA}$	<b>2.4</b>			V
$V_{OL}$ Low Level Output Voltage	$I_{OL} = 1.6\text{ mA}$			<b>0.4</b>	V

Specifications subject to change without notice.

Specifications shown in **boldface** are tested on all devices at final electrical test at worst case temperature. Results from those tests are used to calculate outgoing quality levels. All min and max specifications are guaranteed, although only those shown in boldface are tested.

### ABSOLUTE MAXIMUM RATINGS\*

$V_{CC}$ to $V_{EE}$ .....	-0.3 V to +26.4 V
$V_{DD}$ to DGND .....	-0.3 V to +7 V
$V_{CC}$ to AGND .....	-0.3 V to +18 V
$V_{EE}$ to AGND .....	-18 V to +0.3 V
AGND to DGND .....	$\pm 0.3\text{ V}$
Digital Inputs to DGND .....	0 V to 5.5 V
Analog Inputs, $V_{REF}$ to AGND .....	( $V_{CC} + 0.3\text{ V}$ ) to ( $V_{EE} - 0.3\text{ V}$ )

Soldering .....	+300°C, 10 sec
Storage Temperature .....	-60°C to +100°C

\*Stresses greater than those listed under "Absolute Maximum Ratings" may cause permanent damage to the device. This is a stress rating only and functional operation of the device at these or any other conditions above those indicated in the operational section of this specification is not implied. Exposure to absolute maximum rating conditions for extended periods may affect device reliability.

### CAUTION

ESD (electrostatic discharge) sensitive device. Electrostatic charges as high as 4000 V readily accumulate on the human body and test equipment and can discharge without detection. Although the AD1876 features proprietary ESD protection circuitry, permanent damage may occur on devices subjected to high energy electrostatic discharges. Therefore, proper ESD precautions are recommended to avoid performance degradation or loss of functionality.



## TIMING SPECIFICATIONS<sup>1</sup> ( $T_{MIN}$ to $T_{MAX}$ , $V_{CC} = +12\text{ V} \pm 5\%$ , $V_{EE} = -12\text{ V} \pm 5\%$ , $V_{DD} = +5\text{ V} \pm 10\%$ , $V_{REF} = 5.00\text{ V}$ )

Parameter	Symbol	Min	Typ	Max	Units
Sampling Rate <sup>2</sup>	$f_S = 1/t_S$	1		100	kSPS
Sampling Period <sup>2</sup>	$t_S = 1/f_S$	10		1000	$\mu\text{s}$
Acquisition Time (Included in $t_S$ )	$t_A$	2			$\mu\text{s}$
Calibration Time	$t_{CT}$			5000	$t_C$
CLK Period	$t_C$	480			ns
CAL to BUSY Delay	$t_{CALB}$	0			ns
CLK to BUSY Delay	$t_{CB}$	50	120	175	ns
CLK to $D_{OUT}$ Hold Time	$t_{CD}$	10			ns
CLK HIGH	$t_{CH}$	160			ns
CLK LOW	$t_{CL}$	50			ns
$D_{OUT}$ CLK LOW	$t_{DCL}$	30	80	200	ns
SAMPLE LOW to 1st CLK Delay	$t_{SC}$	50			ns
CAL HIGH Time	$t_{CALH}$	4			$t_C$
CLK to $D_{OUT}$ CLK	$t_{CDH}$	150	200	275	ns
SAMPLE LOW	$t_{SL}$	50			ns

### NOTES

<sup>1</sup>See Figure 1 and Figure 2 and the Conversion Control and Autocalibration sections for detailed explanations of the above timing.

<sup>2</sup>Depends upon external clock frequency; includes acquisition time and conversion time. The minimum sampling rate/maximum sampling period is specified to account for droop of the internal sample/hold. Operation at slower rates than specified may degrade performance.

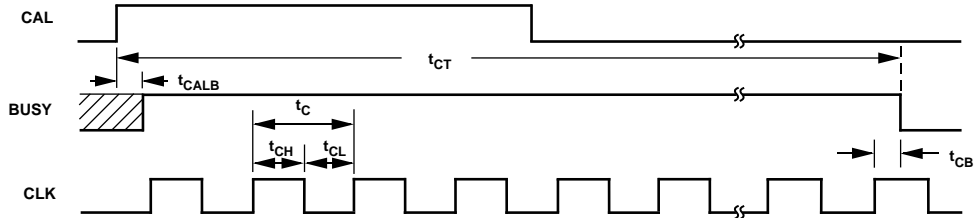

Figure 1. AD1876 Calibration Timing

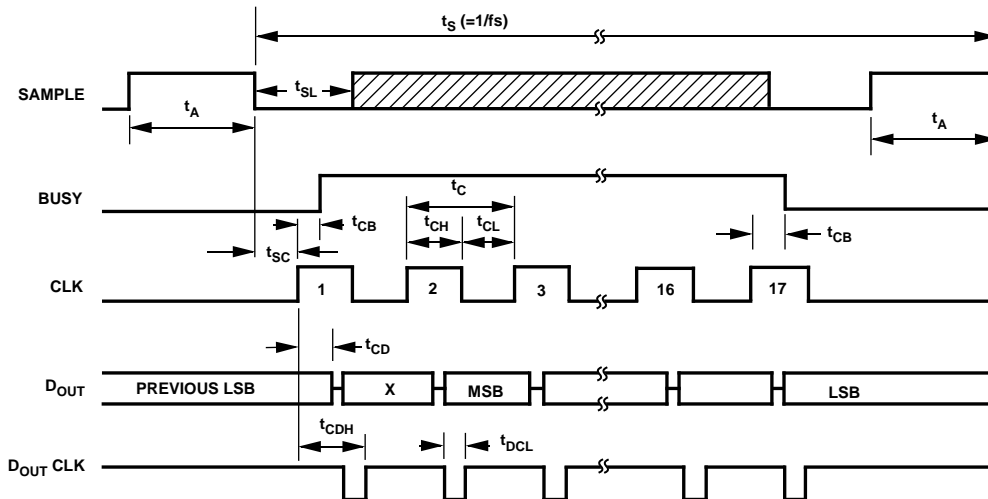

Figure 2. Recommended AD1876 Conversion Timing

## Definition of Specifications

### NYQUIST FREQUENCY

An implication of the Nyquist sampling theorem, the “Nyquist Frequency” of a converter is that input frequency which is one-half the sampling frequency of the converter.

### TOTAL HARMONIC DISTORTION

Total harmonic distortion (THD) is measured as the ratio of the rms sum of the first nineteen harmonic components to the rms value of a 1 kHz full-scale sine wave input signal and is expressed in percent (%) or decibels (dB). For input signals or harmonics that are above the Nyquist frequency, the aliased component is used.

### SIGNAL-TO-NOISE PLUS DISTORTION RATIO

Signal-to-noise plus distortion (S/N+D) is defined to be the ratio of the rms value of the measured input signal to the rms sum of all other spectral components below the Nyquist frequency, including harmonics but excluding dc.

### D-RANGE DISTORTION

D-range distortion is the ratio of the distortion plus noise to the signal at a signal amplitude of -60 dB. In this case, an A-weight filter is used. The value specified for D-range performance is the ratio measured plus 60 dB.

### BANDWIDTH

The full power bandwidth is that input frequency at which the amplitude of the reconstructed fundamental is reduced by 3 dB for a full-scale input.

### INTERMODULATION DISTORTION (IMD)

With inputs consisting of sine waves at two frequencies,  $f_a$  and  $f_b$ , any device with nonlinearities will create distortion products, of order  $(m+n)$ , at sum and difference frequencies of  $mf_a \pm nf_b$ , where  $m, n = 0, 1, 2, 3, \dots$ . Intermodulation terms are those for which  $m$  or  $n$  is not equal to zero. For example, the second order terms are  $(f_a + f_b)$  and  $(f_a - f_b)$ , and the third order terms are  $(2f_a + f_b)$ ,  $(2f_a - f_b)$ ,  $(f_a + 2f_b)$  and  $(f_a - 2f_b)$ . The IMD products are expressed as the decibel ratio of the rms sum of the measured input signals to the rms sum of the distortion terms. The two signals applied to the converter are of equal amplitude, and the peak value of their sum is -0.05 dB from full scale. The IMD products are normalized to a 0 dB input signal.

### APERTURE DELAY

Aperture delay is the time required after SAMPLE is taken LOW for the internal sample-and-hold of the AD1876 to open, thus holding the value of  $V_{IN}$ .

### APERTURE JITTER

Aperture jitter is the variation in the aperture delay from sample to sample.

PIN DESCRIPTION

Pin No.	Name	Type	Description
1	SAMPLE	DI	$V_{IN}$ Acquisition Control Pin. During conversion, SAMPLE controls the state of the internal Sample-Hold Amplifier and initiates conversion (see “Conversion Control” paragraph). During calibration, SAMPLE is active HIGH, forcing $D_{OUT}$ (Pin 3) LOW. If SAMPLE is LOW during calibration, $D_{OUT}$ will output diagnostic information (See “Autocalibration” paragraph.)
2	CLK	DI	Master Clock Input. The AD1876 requires 17 clock pulses to execute a conversion. CLK is also used to derive $D_{OUT}$ CLK (Pin 14). During calibration, 5000 clock pulses are applied.
3	$D_{OUT}$	DO	Serial Output Data, Twos Complement format.
4	DGND	P	Digital Ground.
5	$V_{CC}$	P	+12 V Analog Supply Voltage.
6	N/C	-	No Connection.
7	N/C	-	No Connection.
8	AGND	P/AI	Analog Ground.
9	AGND SENSE	AI	Analog Ground Sense.
10	$V_{IN}$	AI	Analog Input Voltage, referred the AGND SENSE.
11	$V_{REF}$	AI	External Voltage Reference Input, referred to AGND.
12	$V_{EE}$	P	-12 V Analog Supply Voltage.
13	$V_{DD}$	P	+5 V Logic Supply Voltage.
14	$D_{OUT}$ CLK	DO	The rising edge of $D_{OUT}$ CLK may be used to latch $D_{OUT}$ (Pin 3). $D_{OUT}$ CLK is derived from CLK.
15	BUSY	DO	Status Line for Converter. Active HIGH, indicating a conversion or calibration in progress.
16	CAL	DI	Calibration Control Pin (asynchronous).

Type: AI = Analog Input.  
 DI = Digital Input.  
 DO = Digital Output.  
 P = Power.

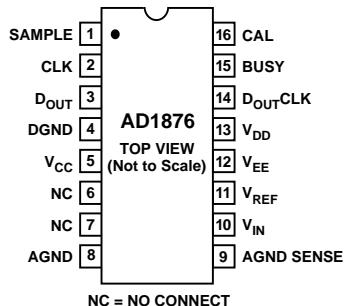

Package Pinout

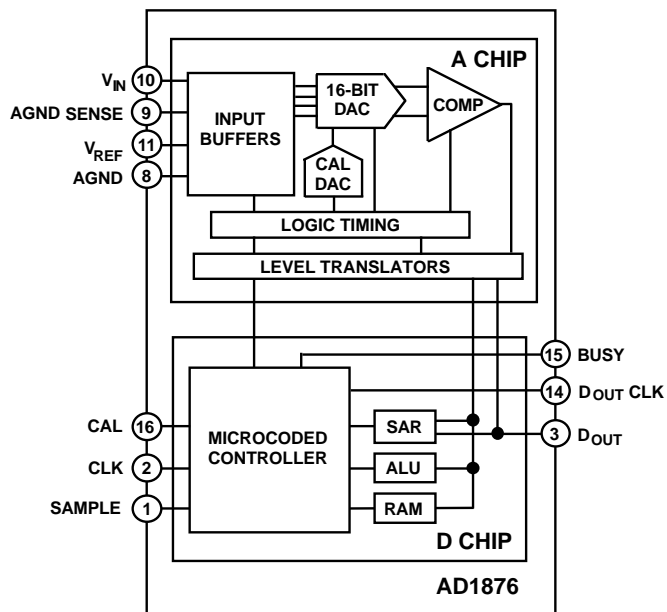

Functional Block Diagram

# AD1876

## FUNCTIONAL DESCRIPTION

The AD1876 is a 16-bit analog-to-digital converter including a sample/hold input circuit, successive approximation register, ground sensing circuitry, serial output port and a microcontroller based autocalibration circuit. These functions are segmented onto two monolithic chips, an analog signal processor and a digital controller. Both chips are contained within the AD1876 package.

The AD1876 employs a successive-approximation technique to determine the value of the analog input voltage. However, instead of the traditional laser-trimmed resistor-ladder approach, the AD1876 uses a capacitor-array, charge-redistribution technique. An array of binary-weighted capacitors subdivides the input value to perform the actual analog to digital conversion. This capacitor array also serves a sample/hold function without the need for additional external circuitry.

The autocalibration circuit within the AD1876 employs a microcontroller and calibration DAC to measure and compensate capacitor mismatch errors. As each error is determined, its value is stored in on-chip memory (RAM). Subsequent conversions use these RAM values to improve conversion accuracy. The autocalibration routine may be invoked at any time. Autocalibration insures high performance while eliminating the need for any user adjustments, and is described in detail below.

The microcontroller controls all of the various functions within the AD1876. These include the actual successive approximation routine, the autocalibration routine, the sample/hold operation, and the serial data transmission.

## AUTOCALIBRATION

The AD1876 achieves rated performance without the need for user trims or adjustments. This is accomplished through the use of on-chip autocalibration.

In the autocalibration sequence, sample/hold offset is nulled by internally connecting the input circuit to the ground sense circuit. The resulting offset voltage is measured and stored in RAM for later use. Next, the capacitor representing the most significant bit (MSB) is charged to the reference voltage. This charge is then inverted and shared between the MSB capacitor and one of equal size composed of all the least significant bits. The difference in the summation of the charges in each of the equally sized capacitors represents the amount of capacitor mismatch. A calibration D/A converter (DAC) adds an appropriate value of error correction voltage to cancel the mismatch. This correction factor is also stored in RAM. This process is repeated for each of the capacitors representing the remaining bits. The accumulated values in RAM are then used during subsequent conversions to adjust conversion results.

As shown in Figure 1, when CAL is taken HIGH the AD1876 internal circuitry is reset, the BUSY pin is driven HIGH and the part prepares for calibration. This is a 'hard' reset and will interrupt any conversion or calibration currently in progress. In order to guarantee that all internal undefined states are cleared, the CAL pin should be held HIGH for at least 4 CLK cycles. Actual calibration begins when the CAL pin is taken LOW and completes in less than 5000 clock cycles or about 2.5 msec with a continuous 500 nsec clock.

During calibration the SAMPLE pin adopts an alternative function. If it is held LOW, D<sub>OUT</sub> provides diagnostic test information (not intended to be used by the customer). If SAMPLE is

held HIGH, D<sub>OUT</sub> will be forced LOW. In either case, D<sub>OUT</sub> CLK will continue pulsing. Since the SAMPLE pin has no control over the actual calibration process, normal conversion timing may also be used for calibration. In this case, however, the D<sub>OUT</sub> pin will output test information during those periods that SAMPLE is LOW. BUSY going LOW will always indicate the end of calibration.

A calibration sequence should be followed by one "dummy" conversion to clear the internal circuitry of the AD1876 in order to guarantee subsequent conversion accuracy.

In most applications, it is sufficient to calibrate the AD1876 only upon power-up, in which case care should be taken that the power supplies and voltage reference have stabilized first.

## CONVERSION CONTROL

The AD1876 is controlled by two signals: SAMPLE and CLK, as shown in Figure 2. It is assumed that the part has been calibrated and the digital I/O pins have the levels shown at the start of the timing diagram.

A conversion consists of an input acquisition followed by 17 clock pulses which are required to run the 16-bit internal successive approximation routine. The analog input is acquired by taking the SAMPLE line HIGH for a minimum acquisition time of  $t_A$ . The actual sample taken is the voltage present on V<sub>IN</sub> at the instant the SAMPLE pin is brought LOW. Care should be taken to ensure that this negative edge is well defined and jitter free to reduce the uncertainty (noise) in ac signal acquisition. On that edge the AD1876 commits itself to the initiated conversion—the input at V<sub>IN</sub> is disconnected from the internal capacitor array and the SAMPLE input will be ignored until the conversion is completed (i.e., BUSY goes LOW). After a delay of at least  $t_{SC}$  (SAMPLE to CLK setup) the 17 CLK cycles are applied. BUSY is asserted after the first positive edge on CLK and reset after the 17th. Both the D<sub>OUT</sub> and the D<sub>OUT</sub> CLK outputs are generated in response to the rising edges of valid CLK pulses. As indicated in the timing diagram, the 2s complement output data is presented MSB first. This data may be captured with the rising edge of D<sub>OUT</sub> CLK or the falling edge of CLK provided  $t_{CH} \geq t_{CDH}$ . The AD1876 will ignore CLK after BUSY has gone LOW and not change D<sub>OUT</sub> or D<sub>OUT</sub> CLK until a new sample is acquired. SAMPLE will no longer be ignored after BUSY goes LOW, and so an acquisition may be initiated even during the HIGH time of the 17th CLK pulse for maximum throughput rate while enabling full settling of the sample/hold circuitry. Note that if SAMPLE is already HIGH when BUSY goes LOW, then an acquisition is immediately initiated and  $t_A$  starts from that time.

During signal acquisition and conversion, care should be taken with the logic inputs to avoid digital feedthrough noise. It is not recommended that CLK be running during V<sub>IN</sub> sampling. If a continuous CLK is used, then the user must avoid CLK edges at the instant of disconnecting V<sub>IN</sub>, i.e., the falling edge of SAMPLE (see the  $t_{SC}$  specifications). The LOW level time of CLK ( $t_{CL}$ ) should be at least 100 ns to avoid the negative edge transition disturbing the internal comparator's settling (whose decision is latched on the positive edge of each valid CLK). For the same reason, it is also not recommended that the SAMPLE pin change state during conversion (i.e., until after BUSY returns LOW).

Internal dc error terms such as comparator voltage offset are sampled, stored on internal capacitors and used to correct for their corresponding errors when needed. Because these voltages are stored on capacitors, they are subject to leakage decay and so require refreshing. For this reason the part is required to be run continuously—i.e., there is a minimum  $t_S$  specification. If the part has been idle for too long (i.e.,  $t_S$  has expired) then a dummy conversion cycle is required to refresh these correction voltages.

BUSY is HIGH during a conversion and goes LOW when the conversion is completed. The twos complement output data is presented MSB first, with MSB data valid on the rising edge of the second  $D_{OUT}$  CLK pulse. Subsequent data is valid on rising edges of subsequent  $D_{OUT}$  CLK pulses. Table I illustrates the AD1876 output coding.

**Table I. Serial Output Coding Format (Twos Complement)**

$V_{IN}$	Output Code
-Full Scale	100 . . . 00
-Full Scale + 1 LSB	100 . . . 01
Midscale - 1 LSB	111 . . . 11
Midscale	000 . . . 00
Midscale + 1 LSB	000 . . . 01
Full Scale - 1 LSB	011 . . . 10
Full Scale	011 . . . 11

A simple method for generating the required signals for the AD1876 is to connect one or more AD1876s to an NPC SM5805 digital filter. This device supplies all signals required to operate the AD1876 at a 96 kHz sample rate, which is  $2 \times F_S$  for audio applications. This is more fully discussed in the applications section of this data sheet, accompanied by Figures 9 and 10.

## APPLICATIONS

### POWER SUPPLIES AND DECOUPLING

The AD1876 has three power supply input pins.  $V_{EE}$  and  $V_{CC}$  provide the supply voltages to operate the analog portions of the AD1876 including the ADC and SHA.  $V_{DD}$  provides the supply voltage which operates the digital portions of the AD1876 including the serial output port and the autocalibration controller.

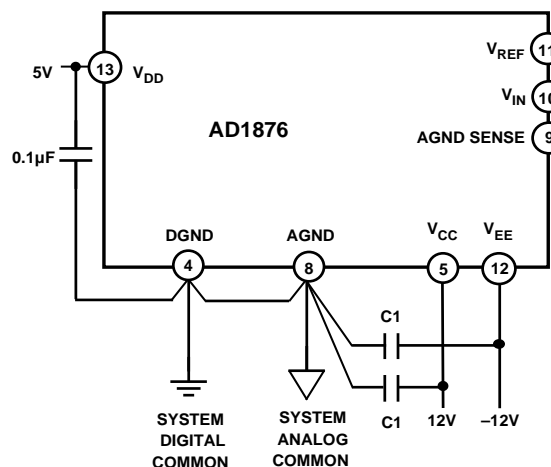

*Figure 3. Grounding and Decoupling the AD1876*

Decoupling capacitors should be used on all power supply pins. These capacitors should be placed as close as possible to the package pins as well as the ground connections. The logic supply ( $V_{DD}$ ) should be decoupled to digital common (DGND) with a 0.1  $\mu\text{F}$  ceramic capacitor, and the analog supplies ( $V_{EE}$  and  $V_{CC}$ ) should be decoupled to analog common (AGND) with 4.7  $\mu\text{F}$  and 0.1  $\mu\text{F}$  tantalum capacitors in parallel, represented by C1. An effort should be made to minimize the trace length between the capacitor leads and the respective converter power supply and common pins. The recommended decoupling scheme is illustrated in Figure 3.

As with most high performance linear circuits, changes in the power supplies can produce undesired changes in the performance of the circuit. Analog Devices recommends that well regulated power supplies with less than 1% ripple be incorporated into the design of any system using these devices.

### BOARD LAYOUT

Designing with high resolution data converters requires careful attention to board layout. Trace impedance is a significant issue. A 1.22 mA current through a 0.5  $\Omega$  trace will develop a voltage drop of 0.6 mV, which is 4 LSBs at the 16 bit level for a 10 V full-scale span. In addition to ground drops, inductive and capacitive coupling need to be considered, especially when high accuracy analog signals share the same board with digital signals. Finally, power supplies need to be decoupled in order to filter ac noise.

Analog and digital signals should not share a common return path. Each signal should have an appropriate analog or digital return routed close to it. Using this approach, signal loops enclose a small area, minimizing the inductive coupling of noise. Wide PC tracks, large gauge wire, and ground planes are highly recommended to provide low impedance signal paths. Separate analog and digital ground planes are also desirable, with a single interconnection point to minimize ground loops. Analog signals should be routed as far as possible from digital signals and should cross them, if at all, only at right angles. A solid analog ground plane around the AD1876 will isolate large switching ground currents. For these reasons, the use of wire wrap circuit construction is not recommended; careful printed circuit construction is preferred.

### GROUNDING

The AD1876 has three grounding pins, designated ANALOG GROUND (AGND), DIGITAL GROUND (DGND) and ANALOG GROUND SENSE (AGND SENSE). The analog ground pin is the “high quality” ground reference point for the device. The analog ground pin should be connected to the analog common point in the system.

AGND SENSE is intended to be connected to the input signal ground reference point. This allows for slight differences in level between the analog ground point in the system and the input signal ground point. However, no more than 100 mV is recommended between the analog ground pin and the analog ground sense pin for specified performance.

The digital ground pin is the reference point for all of the digital signals that operate the AD1876. This pin should be connected to the digital common point in the system. As illustrated in Figure 3, the analog and digital grounds should be connected together at one point in the system.

# AD1876

## VOLTAGE REFERENCE

The AD1876 requires the use of an external voltage reference. The input voltage range is determined by the value of the reference voltage; in general, a reference voltage of  $n$  volts produces an input range of  $\pm n$  volts. Signal-to-noise performance is increased proportionately with input signal range. The AD1876 is specified with a 5.0 V reference and an analog input of  $\pm 5$  V. In the presence of a fixed amount of system noise, increasing the LSB size (which results from increasing the reference voltage) will increase the effective  $S/(N+D)$  performance for input values below the point where input distortion occurs. Figure 11 illustrates  $S/(N+D)$  as a function of input amplitude and reference voltage.

During a conversion, the switched capacitor array of the AD1876 presents a dynamically changing current load at the voltage reference as the successive-approximation algorithm cycles through various choices of capacitor weighting. The output impedance of the reference circuitry must be low so that the output voltage will remain sufficiently constant as the current drive changes. In most applications, this requires that the output of the voltage reference be buffered by an amplifier with low impedance at relatively high frequencies. A (10  $\mu$ F or larger) capacitor connected between  $V_{REF}$  and AGND will reduce the demands on the reference by decreasing the magnitude of high frequency components.

The following two sections represent typical design approaches.

## VOLTAGE REFERENCE—AUDIO APPLICATIONS

Audio applications require optimal ac performance over a relatively narrow temperature range, with low cost being important. Figure 4 shows one such approach towards attaining these goals. A voltage reference, consisting of a Zener diode, capacitor, resistor and op amp with typical component values, is shown. This simple circuit has the advantage of low cost, but the reference voltage value is sensitive to changes in the +12 V supply. Additionally, changes in the Zener value due to temperature variations will also be reflected in the reference voltage.  $R_{OPTION}$  may be required for other component selections if the Zener requires more current than the op amp can supply.

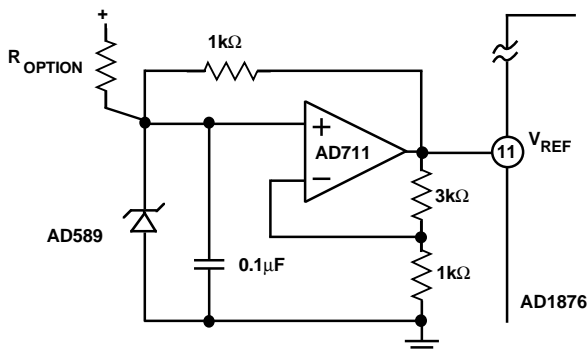

Figure 4. Low Cost Voltage Reference Circuit

## VOLTAGE REFERENCE—PRECISION MEASUREMENT APPLICATIONS

In applications other than audio, parameters such as low drift over temperature and static accuracy are important. Figure 5 shows a voltage reference circuit featuring the 5 V AD586. The AD586 is a low cost reference which utilizes a buried Zener architecture to provide low noise and drift. Over the 0°C to

+70°C range, the AD586L grade exhibits less than a 2.25 mV output change from its initial value at +25°C. A noise-reduction capacitor,  $C_N$ , reduces the broadband noise of the AD586 output, thereby optimizing the overall performance of the AD1876.

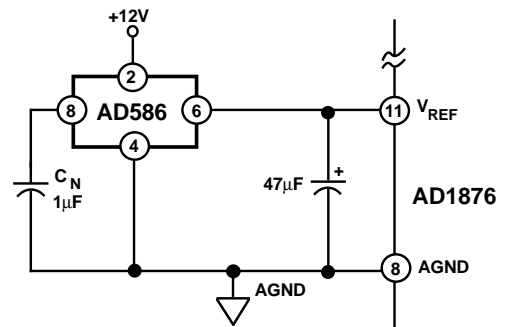

Figure 5.

For higher performance needs, the AD588 reference provides improved drift, low noise, and excellent initial accuracy. The AD588 uses a proprietary ion-implanted buried Zener diode in conjunction with laser-trimmed thin-film resistors for low offset and gain. The AD588 output is accurate to 0.65 mV from its value at +25°C over the 0°C to +70°C range. The circuit shown in Figure 6 includes a noise-reduction network on Pins 4, 6 and 7. The 1  $\mu$ F capacitors form low-pass filters with the internal resistance of the AD588 and external 3.9 k $\Omega$  resistor. This reduces the wide-band (to 1 MHz) noise of the AD588, providing optimum performance of the AD1876.

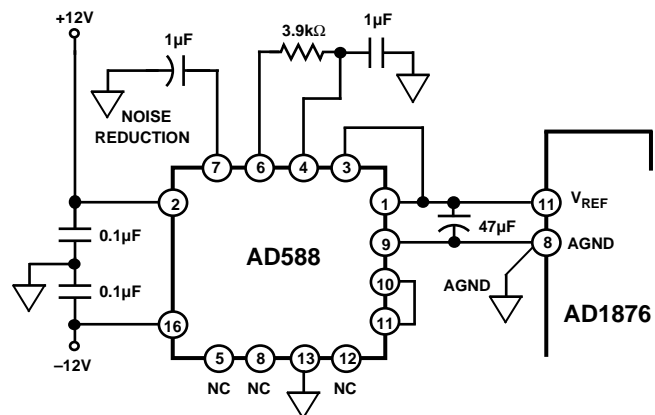

Figure 6.

## ANALOG INPUT

As previously discussed, the analog input voltage range for the AD1876 is  $\pm V_{REF}$ . For purposes of ground drop and common-mode rejection, the  $V_{IN}$  and  $V_{REF}$  inputs each have their own ground.  $V_{REF}$  is referred to the local analog system ground (AGND), and  $V_{IN}$  is referred to the analog ground sense pin (AGND SENSE) which allows a remote ground sense for the input signal. If AGND SENSE is not used, it should be connected to the AGND pin at the package. The AGND SENSE pin is intended to be tied to potentials within 100 mV of AGND to maintain specified performance.

The AD1876 analog inputs ( $V_{IN}$ ,  $V_{REF}$  and AGND SENSE) exhibit dynamic characteristics. When a conversion cycle begins, each analog input is connected to an internal, discharged 50 pF capacitor which then charges to the voltage present at the

corresponding pin. The capacitor is disconnected when SAMPLE is taken LOW and the stored charge is used in the subsequent A/D conversion. In order to limit the demands placed on the external source by this high initial charging current, an internal buffer amplifier is employed between the input and this capacitance for a few hundred nanoseconds. During this time the input pin exhibits typically 20 k $\Omega$  input resistance, 10 pF input capacitance and  $\pm 40$   $\mu$ A bias current. Next, the input is switched directly to the now precharged capacitor and allowed to fully settle, after which SAMPLE is taken LOW. During this time the input sees only a 50 pF capacitor. Once the sample is taken, the input is internally floated so that the external input source sees a very high input resistance and a parasitic input capacitance of typically only 2 pF. As a result, the only dominant input characteristic which must be considered is the high current steps which occur when the internal buffers are switched in and out.

In most cases, it is desirable to use external op amps to drive the AD1876. For ac applications where low cost and low distortion are desired, the AD711 may be used as shown in Figure 7. Another option is the 5532/5534 series. Care should always be taken with op amp selection—many available op amps do not meet the necessary low distortion requirements with even moderate loading conditions.

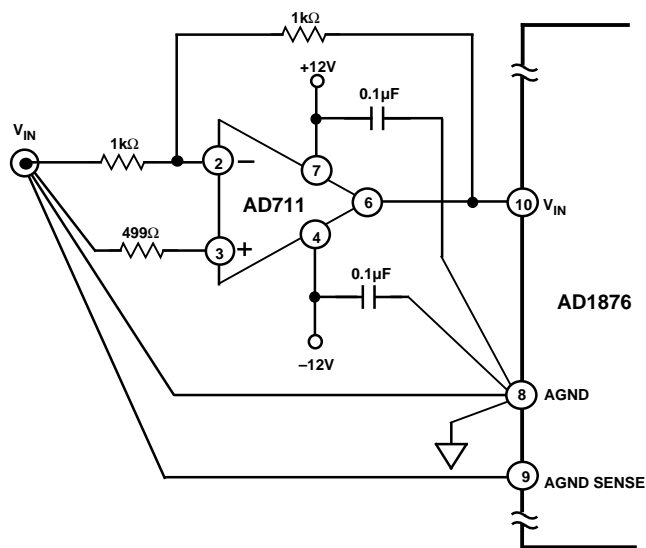

Figure 7.

### TESTING THE AD1876

Analog Devices employs a high performance mixed signal VLSI tester to verify the electrical performance of every AD1876. The test system consists of two main sections, an input signal generator and a digital data and control section.

The stimulus section is responsible for providing a high purity, noise-free, band limited tone to the input of the device. This input frequency is 1.06 kHz. The test tone is passed through a bandpass filter to remove distortion products and then buffered by a high performance op amp. An external 5.000 V reference voltage is also supplied by this section.

The control section of the test equipment provides an external clock and the control signals for calibration, conversion and data transmission. This section of the tester also contains the processing unit that calculates the actual performance of the device under test.

The test procedure consists of the following steps. First, the device is calibrated by its on-board controller. Next, the device under test digitizes the input waveform. This conversion is performed at a 96 kSPS rate and transmits the resulting serial data to the tester. The tester performs an FFT on the test data and determines the actual performance of the device.

### AC PERFORMANCE

Using the aforementioned test methodology, ac performance of the AD1876 is measured. AC parameters, which include  $S/(N+D)$ , THD, etc., reflect the AD1876's effect on the spectral content of the analog input signal. Figures 11 through 15 provide information on the AD1876's ac performance under a variety of conditions.

As a general rule, averaging the results from several conversions reduces the effects of noise and, therefore, improves such parameters as  $S/(N+D)$  and THD. AD1876 performance is optimized by operating the device at its maximum sample rate of 100 kSPS and digitally filtering the resulting bit stream to the desired signal bandwidth. This succeeds in distributing noise over a wider frequency range, thus reducing the noise density in the frequency band of interest. This subject is discussed in the following section.

### OVERSAMPLING AND NOISE FILTERING

The Nyquist rate for a converter is defined as one-half its sampling rate. This is established by the Nyquist theorem, which requires that a signal be sampled at a rate corresponding to at least twice its widest bandwidth of interest in order to preserve the information content. Oversampling is a conversion technique in which the sampling frequency is an integral (2 or more) multiple of twice the frequency bandwidth of interest. In audio applications, the AD1876 can operate at a 2 $\times$  oversampling rate.

In quantized systems, the information content of the analog input is represented in the frequency spectrum from dc to the Nyquist rate of the converter. Within this same spectrum are higher frequency aliased noise components. Antialias, or low-pass, filters are used at the input to the ADC to remove the portion of these noise components attributed to high frequency analog input noise. However, wideband noise contributed by the AD1876 will not be reduced by the antialias filter. The AD1876 contributed noise is evenly distributed from dc to the Nyquist rate, and this fact can be used to minimize its overall effect.

The AD1876 contributed noise effects can be reduced by oversampling—sampling at a rate higher than defined by the Nyquist theorem. This spreads the noise energy over a distribution of frequencies wider than the frequency band of interest, and by judicious selection of a digital filter, noise frequencies outside the bandwidth of interest may be eliminated. The process of quantization inherently produces noise, known as quantization noise. The magnitude of this noise is a function of the resolution of the converter, and manifests itself as a limit to the theoretical signal-to-noise ratio achievable. This limit is described by  $S/(N+D) = (6.02n + 1.76 + 10 \log F_s/2 F_a)$  dB, where  $n$  is the resolution of the converter in bits,  $F_s$  is the sampling frequency, and  $F_a$  is the signal bandwidth of interest. For audio bandwidth applications, the AD1876 is capable of operating at a 2 $\times$  oversample rate (96 kSPS), which typically produces an improvement in  $S/(N+D)$  of 3 dB compared with operating at the Nyquist conversion rate of 48 kSPS. Oversampling has another advantage as well; the demands on the antialias filter are

# AD1876

lessened. In summary, system performance is optimized by running the AD1876 at or near its maximum sampling rate of 100 kHz and digitally filtering the resulting spectrum to eliminate undesired frequencies.

## DSP INTERFACE

Figure 8 illustrates the use of the Analog Devices ADSP-2101 digital signal processor with the AD1876. The ADSP-2101 FO (flag out) pin of serial port 1 (SPORT 1) is connected to the SAMPLE line and is used to control acquisition of data. The ADSP-2101 timer is used to provide precise timing of the FO pin.

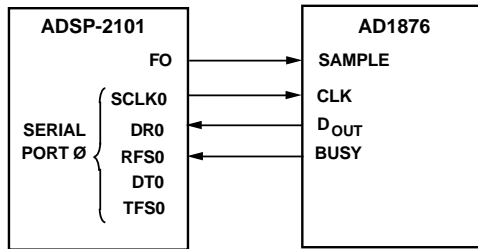

Figure 8. ADSP-2101 Interface

The SCLK pin of the ADSP-2101 SPORT0 provides the CLK input for the AD1876. The clock should be programmed to be approximately 2 MHz to comply with AD1876 specifications. To minimize digital feedthrough, the clock should be disabled (by setting Bit 14 in SPORT0 control register to 0) during data acquisition. Since the clock floats when disabled, a pull-down resistor of 12 k–15 kΩ should be connected to SCLK to ensure it will be LOW at the falling edge of SAMPLE. To maximize the conversion rate, the serial clock should be enabled immediately after SAMPLE is brought LOW (hold mode).

The AD1876 BUSY signal is connected to RFS0 to notify SPORT0 when a new data word is coming. SPORT0 should be configured in normal, external, noninverting framing mode and

can be programmed to generate an interrupt after the last data bit is received. To maximize the conversion rate, SAMPLE should be brought HIGH immediately after the last data bit is received.

## SIGNAL PROCESSING

An audio spectrum analyzer can be produced by combining an AD1876 and an ADSP-2101 signal processing microcomputer. This system can analyze signals from dc to 50 kHz depending on the sample rate. This is ideal for applications such as audio analysis, but could also be applied to vibration analysis as well.

## AUDIO DELAY LINE

A high performance, 16-bit stereo delay line can be constructed from two AD1876 audio ADCs, a signal processing microcomputer and two AD1856 audio DACs. Depending on the length of the internal buffer which produces the delay, a variable delay is possible. Other applications are also possible with only a change in software. For example, a reverb or echo effect could be generated as well.

## AD1876 AND SM5805 DIGITAL FILTER @ 2 F<sub>S</sub>

A simple method for generating the required signals for the AD1876 is to connect one or more AD1876s to an NPC SM5805 digital filter. This device supplies all signals required to operate the AD1876 at a 96 kHz sample rate, which is  $2 \times F_S$  for audio applications.

To minimize group delay distortion, the input to the AD1876 is filtered only by a low order analog filter. The AD1876 samples the output of the filter at  $2 F_S$  (96 kHz). To prevent aliasing, the SM5805 filters the data with a sharp, linear phase filter rolling off at  $0.5 F_S$ . The resulting data is decimated to a sample rate of 48 kSPS.

Interfacing the two chips is straightforward, as shown in Figure 9. The start signal for the AD1876 (for 96 kSPS operation) is provided by the S/H pin of the SM5805, and CLK is derived from the BCC pin. Figure 10 illustrates the corresponding timing diagram.

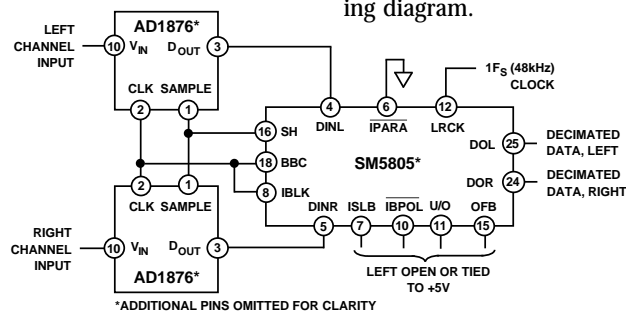

Figure 9. AD1876 and SM5805 Digital Filter

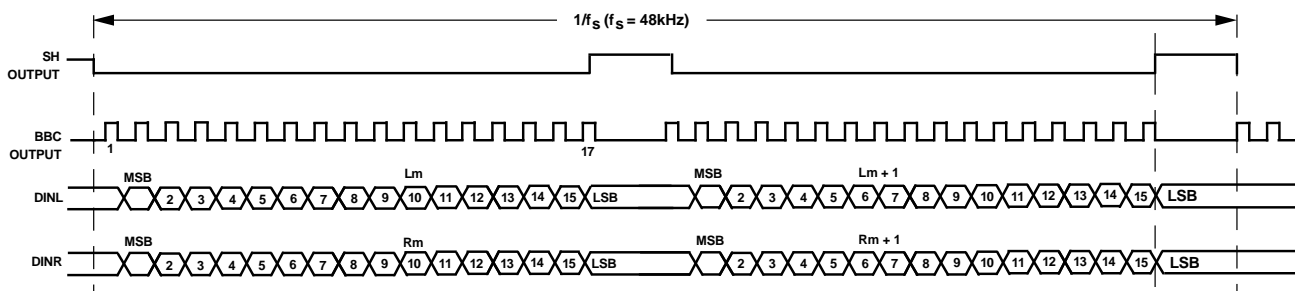

Figure 10. SM5805 Timing Diagram

# Typical Dynamic Performance—AD1876

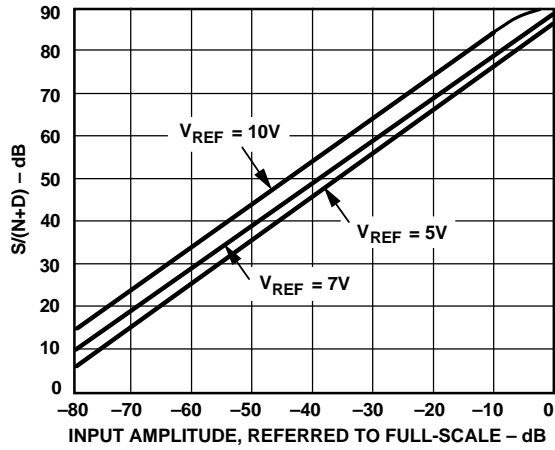

Figure 11.  $S/(N+D)$  vs.  $V_{REF}$  vs. Input Amplitude

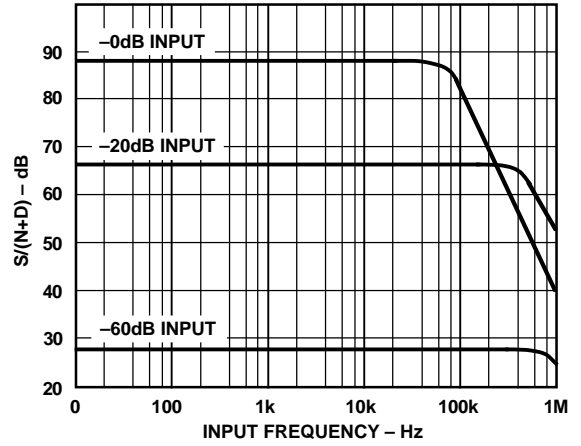

Figure 12.  $S/(N+D)$  vs. Input Frequency and Amplitude

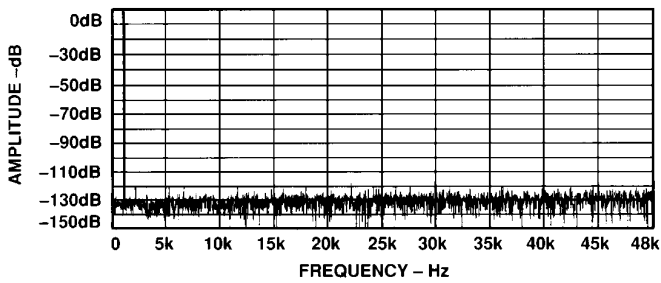

Figure 13. 4096 Point FFT at 96 kSPS,  $f_{IN} = 1.06$  kHz

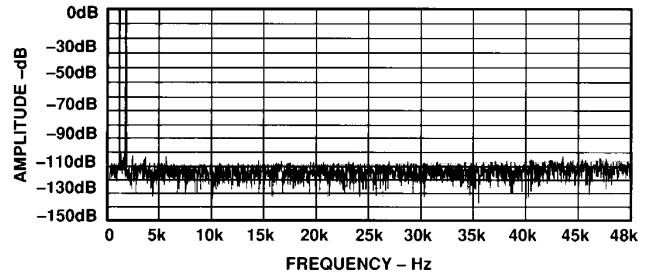

Figure 14. IMD Plot for  $f_{IN} = 1008$  Hz ( $f_a$ ), 1055 Hz ( $f_b$ ) at 96 kSPS

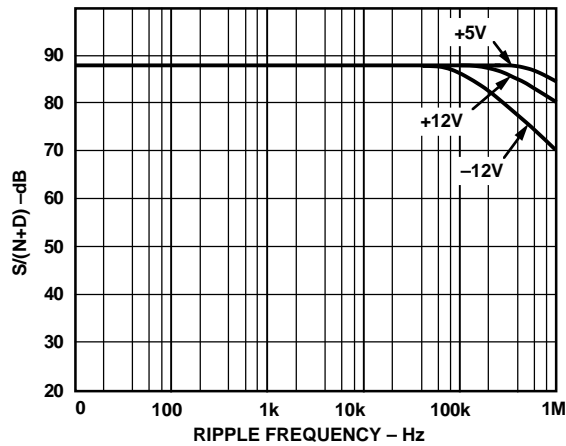
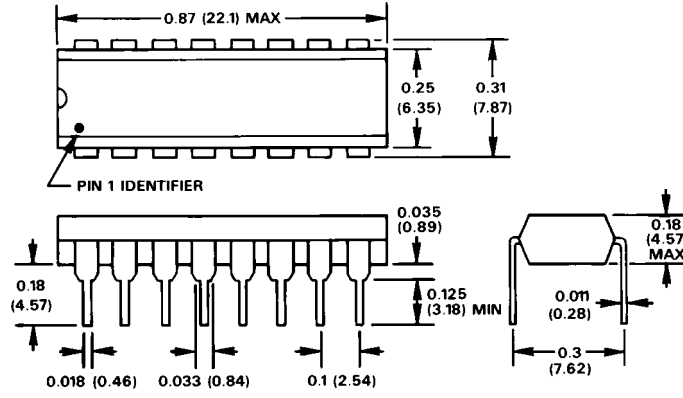

Figure 15. Power Supply Rejection ( $f_{IN} = 1.06$  kHz,  $f_{SAMPLE} = 96$  kSPS,  $V_{RIPPLE} = 0.3$  V p-p)

**OUTLINE DIMENSIONS**  
 Dimensions shown in inches and (mm).

**Plastic DIP (N) Package**





LittleDiode supplies new, hard to find or obsolete electronic components and semiconductors all over the world.

With over two million different components listed you are sure to find the part you need.

Feel free to visit us today at our online store:

**[LittleDiode.com](http://LittleDiode.com)**

Looking forward to providing you with the best possible service.