

FEATURES

- 5 V 3-Channel Audio DAC System
- Accepts Sample Rates up to 48 kHz
- 7 Biquad Filter Sections per Channel
- Dual Dynamic Processor with Arbitrary Input/Output Curve and Adjustable Time Constants
- 0 ms to 6 ms Variable Delay/Channel for Speaker Alignment
- Stereo Spreading Algorithm for Phat Stereo™ Effect
- Program RAM Allows Complete New Program Download via SPI Port
- Parameter RAM Allows Complete Control of More Than 200 Parameters via SPI Port
- SPI Port Features Safe-Upload Mode for Transparent Filter Updates
- 2 Control Registers Allow Complete Control of Modes and Memory Transfers
- Differential Output for Optimum Performance
- 112 dB Signal-to-Noise (Not Muted) at 48 kHz Sample Rate (A-Weighted Stereo)
- 70 dB Stop-Band Attenuation
- On-Chip Clickless Volume Control
- Hardware and Software Controllable Clickless Mute
- Digital De-emphasis Processing for 32 kHz, 44.1 kHz, and 48 kHz Sample Rates
- Flexible Serial Data Port with Right-Justified, Left-Justified, I²S Compatible, and DSP Serial Port Modes
- Auxiliary Digital Input

Graphical Custom Programming Tools
44-Lead MQFP or 48-Lead LQFP Plastic Package

APPLICATIONS

- 2.0/2.1 Channel Audio Systems (Two Main Channels plus Subwoofer)
- Multimedia Audio
- Automotive Sound Systems
- Minicomponent Stereo
- Home Theater Systems (AC-3 Postprocessor)
- Musical Instruments
- In-Seat Sound Systems (Aircraft, Motor Coaches)

GENERAL DESCRIPTION

The AD1954 is a complete 26-bit single-chip 3-channel digital audio playback system with built-in DSP functionality for speaker equalization, dual-band compression/limiting, delay compensation, and image enhancement. These algorithms can be used to compensate for real-world limitations of speakers, amplifiers, and listening environments, resulting in a dramatic improvement of perceived audio quality.

The signal processing used in the AD1954 is comparable to that found in high-end studio equipment. Most of the processing is done in full 48-bit double-precision mode, resulting in very good low-level signal performance and the absence of limit cycles or idle tones. The compressor/limiter uses a sophisticated two-band algorithm often found in high-end broadcast compressors.

(Continued on 9)

FUNCTIONAL BLOCK DIAGRAM

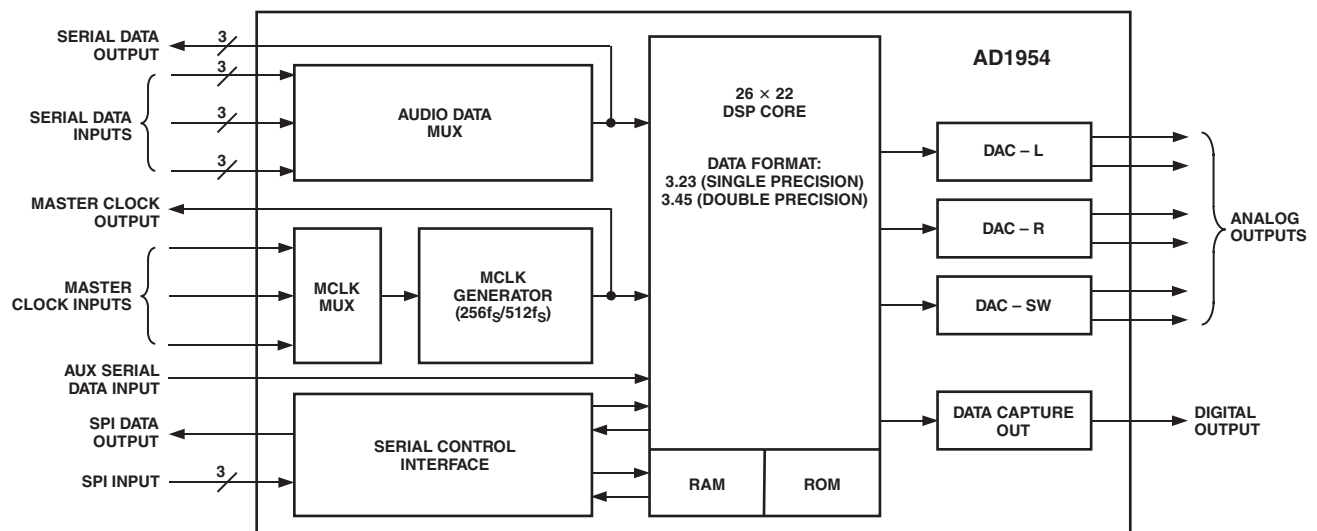

REV. A

Information furnished by Analog Devices is believed to be accurate and reliable. However, no responsibility is assumed by Analog Devices for its use, nor for any infringements of patents or other rights of third parties that may result from its use. No license is granted by implication or otherwise under any patent or patent rights of Analog Devices. Trademarks and registered trademarks are the property of their respective companies.

AD1954

TABLE OF CONTENTS

FEATURES/APPLICATIONS	1	Interpolation Filters	18
GENERAL DESCRIPTION	1	SPI PORT	19
FUNCTIONAL BLOCK DIAGRAM	1	Overview	19
SPECIFICATIONS	3	SPI Address Decoding	20
ABSOLUTE MAXIMUM RATINGS	6	Control Register 1	20
ORDERING GUIDE	6	Control Register 2	21
PIN CONFIGURATIONS	6	Volume Registers	22
PIN FUNCTION DESCRIPTIONS	7	Parameter RAM Contents	22
TYPICAL PERFORMANCE CHARACTERISTICS	8	Options for Parameter Updates	22
GENERAL DESCRIPTION (continued from page 1)	9	Soft Shutdown Mechanism	22
FEATURES	9	Safeload Mechanism	24
PIN FUNCTIONS	10	Summary of RAM Modes	24
SIGNAL PROCESSING	12	SPI READ/WRITE DATA FORMATS	24
Signal Processing Overview	12	INITIALIZATION	26
Numeric Formats	12	Power-Up Sequence	26
Coefficient Format	12	Setting the Clock Mode	26
Internal DSP Signal Data Format	12	Setting the Data and MCLK Input Selectors	26
High-Pass Filter	13	DATA CAPTURE REGISTERS	26
Biquad Filters	13	SERIAL DATA INPUT PORT	29
Volume	14	Serial Data Input Modes	29
Stereo Image Expander	14	DIGITAL CONTROL PINS	29
Delay	15	Mute	29
Main Compressor/Limiter	15	De-emphasis	29
RMS Time Constant	17	ANALOG OUTPUT SECTION	30
RMS Hold Time	17	GRAPHICAL CUSTOM PROGRAMMING TOOLS	31
RMS Release Rate	17	APPENDIX	32
Look-Ahead Delay	17	Cookbook Formulae for Audio EQ Biquad Coefficients	32
Postcompression Gain	17	OUTLINE DIMENSIONS	33
Subwoofer Compressor/Limiter	17	Revision History	34
De-emphasis Filtering	18		
Using the Sub Reinjection Paths for Systems with No Subwoofer	18		

AD1954—SPECIFICATIONS

Test conditions, unless otherwise noted.

Supply Voltages (AV_{DD} , DV_{DD})	5.0 V
Ambient Temperature	25°C
Input Clock	12.288 MHz
Input Signal	1.000 kHz 0 dB Full Scale
Input Sample Rate	48 kHz
Measurement Bandwidth	20 Hz to 20 kHz
Word Width	24 Bits
Load Capacitance	2200 pF
Load Impedance	2.74 k Ω
Input Voltage High	2.1 V
Input Voltage Low	0.8 V

ANALOG PERFORMANCE*

Parameter	Min	Typ	Max	Unit
RESOLUTION		24		Bits
SIGNAL-TO-NOISE RATIO (20 Hz to 20 kHz) (Left/Right Output)				
No Filter (Stereo)		109		dB
With A-Weighted Filter		112		dB
DYNAMIC RANGE (20 Hz to 20 kHz, -60 dB Input) (Left/Right Output)				
No Filter		109		dB
With A-Weighted Filter	108	112		dB
TOTAL HARMONIC DISTORTION PLUS NOISE (Left/Right Output)				
$V_O = -0.5$ dB	-93	-100		dB
SIGNAL-TO-NOISE RATIO (20 Hz to 20 kHz) (Subwoofer Output)				
No Filter (Stereo)		104		dB
With A-Weighted Filter		107		dB
DYNAMIC RANGE (20 Hz to 20 kHz, -60 dB Input) (Subwoofer Output)				
No Filter		104		dB
With A-Weighted Filter	104	107		dB
TOTAL HARMONIC DISTORTION PLUS NOISE (Subwoofer Output)				
$V_O = -0.5$ dB	-90	-96		dB
ANALOG OUTPUTS				
Differential Output Range (\pm Full Scale) (Left/Right Output)		2.74		V p-p
Differential Output Range (\pm Full Scale) (Subwoofer Output)		2.77		V p-p
CMOUT		2.50		V
DC ACCURACY				
Gain Error (Left/Right Channel)	-5		+5	%
Gain Error (Subwoofer Channel)	-8		+8	%
Interchannel Gain Mismatch	-0.250		+0.250	dB
Gain Drift		150		ppm/°C
DC Offset	-30		+30	mV
INTERCHANNEL CROSSTALK (EIAJ Method)		-120		dB
INTERCHANNEL PHASE DEVIATION		± 0.1		Degrees
MUTE ATTENUATION		-107		dB
DE-EMPHASIS GAIN ERROR			± 0.1	dB

*Performance of right and left channels are identical (exclusive of the Interchannel Gain Mismatch and Interchannel Phase Deviation specifications).

Specifications subject to change without notice.

AD1954

SPECIFICATIONS (continued)

DIGITAL I/O

Parameter	Min	Typ	Max	Unit
Input Voltage High (V_{IH})	2.1			V
Input Voltage High (V_{IH}) – RESETB	2.25			V
Input Voltage Low (V_{IL})			0.8	V
Input Leakage (I_{IH} @ $V_{IH} = 2.1$ V)			10	μ A
Input Leakage (I_{IL} @ $V_{IL} = 0.8$ V)			10	μ A
High Level Output Voltage (V_{OH}), $I_{OH} = 2$ mA	DVDD – 0.5			V
Low Level Output Voltage (V_{OL}), $I_{OL} = 2$ mA			0.4	V
Input Capacitance			20	pF

Specifications subject to change without notice.

POWER

Parameter	Min	Typ	Max	Unit
SUPPLIES*				
Voltage, Analog and Digital	4.5	5	5.5	V
Analog Current		42	48	mA
Analog Current, Power-Down		40	46	mA
Digital Current		65	75	mA
Digital Current, SPI Power-Down		6	10	mA
Digital Current, Reset Power-Down		53	61	mA
DISSIPATION				
Operation, Both Supplies		510		mW
Operation, Analog Supplies		210		mW
Operation, Digital Supplies		325		mW
SPI Power-Down, Both Supplies		230		mW
Reset Power-Down, Both Supplies		465		mW
POWER SUPPLY REJECTION RATIO				
1 kHz 300 mV p-p Signal at Analog Supply Pins		–80		dB
20 kHz 300 mV p-p Signal at Analog Supply Pins		–80		dB

*ODVDD current is dependent on load capacitance and clock rate.

Specifications subject to change without notice.

TEMPERATURE RANGE

Parameter	Min	Typ	Max	Unit
Specifications Guaranteed		25		$^{\circ}$ C
Functionality Guaranteed	–40		+105	$^{\circ}$ C
Storage	–55		+125	$^{\circ}$ C

Specifications subject to change without notice.

DIGITAL TIMING

Parameter	Min	Typ	Max	Unit
t _{DMDC} MCLK Recommended Duty Cycle @ 12.288 MHz (256 f _s Mode)	45		55	%
t _{DMDC} MCLK Recommended Duty Cycle @ 24.576 MHz (512 f _s Mode)	40		60	%
t _{DMD} MCLK Delay (All Mode)			25	ns
t _{DBH} BCLK Low Pulsewidth	10			ns
t _{DBH} BCLK High Pulsewidth	10			ns
t _{DBD} BCLK Delay (to BCLKO)			25	ns
t _{DLS} LRCLK Setup	0			ns
t _{DLH} LRCLK Hold	10			ns
t _{DLD} LRCLK Delay (to LRCLKO)			25	ns
t _{DDS} SDATA Setup	0			ns
t _{DDH} SDATA Hold	10			ns
t _{DDD} SDATA Delay (to SDATAO)			25	ns
t _{CCL} CCLK Low Pulsewidth	12			ns
t _{CCH} CCLK High Pulsewidth	12			ns
t _{CLS} CLATCH Setup	10			ns
t _{CLH} CLATCH Hold	10			ns
t _{CLD} CLATCH High Pulsewidth	10			ns
t _{CDS} CDATA Setup	0			ns
t _{CDH} CDATA Hold	10			ns
t _{COD} COUT Delay			35	ns
t _{COH} COUT Hold	2			ns
t _{DCD} DCSOUT Delay			35	ns
t _{DCH} DCSOUT Hold	2			ns
t _{PDRP} PD/RST Low Pulsewidth	5			ns

Specifications subject to change without notice.

DIGITAL FILTER CHARACTERISTICS AT 44.1 kHz

Parameter	Min	Typ	Max	Unit
Pass-Band Ripple			±0.01	dB
Stop-Band Attenuation		70		dB
Pass Band		20		kHz
		$0.5442 \times f_s$		
Stop Band		24		kHz
		$0.4535 \times f_s$		
Group Delay		$24.625/f_s$		sec

Specifications subject to change without notice.

AD1954

ABSOLUTE MAXIMUM RATINGS*

DVDD to DGND	-0.3 V to +6 V
ODVDD to DGND	-0.3 V to +6 V
AVDD to AGND	-0.3 V to +6 V
Digital Inputs	DGND - 0.3 V to DVDD + 0.3 V
Analog Inputs	AGND - 0.3 V to AVDD + 0.3 V
AGND to DGND	-0.3 V to +0.3 V
Reference Voltage	(AVDD + 0.3)/2 V
Maximum Junction Temperature	125°C
Storage Temperature Range	-65°C to +150°C
Soldering	300°C/10 sec

*Stresses above those listed under Absolute Maximum Ratings may cause permanent damage to the device. This is a stress rating only; functional operation of the device at these or any other conditions above those indicated in the operational section of this specification is not implied. Exposure to absolute maximum rating conditions for extended periods may affect device reliability.

Package Characteristics (44-Lead MQFP)

	Min	Typ	Max	Unit
θ_{JA} (Thermal Resistance—Junction to Ambient)		72		°C/W
θ_{JC} (Thermal Resistance—Junction to Ambient)		19.5		°C/W

Package Characteristics (48-Lead LQFP)

	Min	Typ	Max	Unit
θ_{JA} (Thermal Resistance—Junction to Ambient)		76		°C/W
θ_{JC} (Thermal Resistance—Junction to Ambient)		17		°C/W

ORDERING GUIDE

Model	Temperature Range	Package Description	Package Option
AD1954YS	-40°C to +105°C	44-Lead MQFP	S-44
AD1954YSRL	-40°C to +105°C	44-Lead MQFP	S-44 on 13" Reel
AD1954YST	-40°C to +105°C	48-Lead LQFP	ST-48
AD1954YSTRL	-40°C to +105°C	48-Lead LQFP	ST-48 on 13" Reel
AD1954YSTRL7	-40°C to +105°C	48-Lead LQFP	ST-48 on 7" Reel
EVAL-AD1954EB		Evaluation Board	

CAUTION

ESD (electrostatic discharge) sensitive device. Electrostatic charges as high as 4000 V readily accumulate on the human body and test equipment and can discharge without detection. Although the AD1954 features proprietary ESD protection circuitry, permanent damage may occur on devices subjected to high energy electrostatic discharges. Therefore, proper ESD precautions are recommended to avoid performance degradation or loss of functionality.



PIN CONFIGURATIONS

44-LEAD MQFP

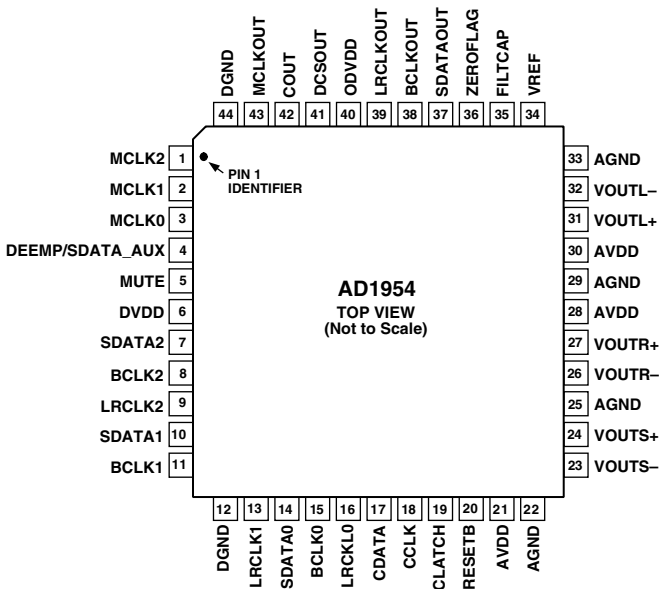

48-LEAD LQFP

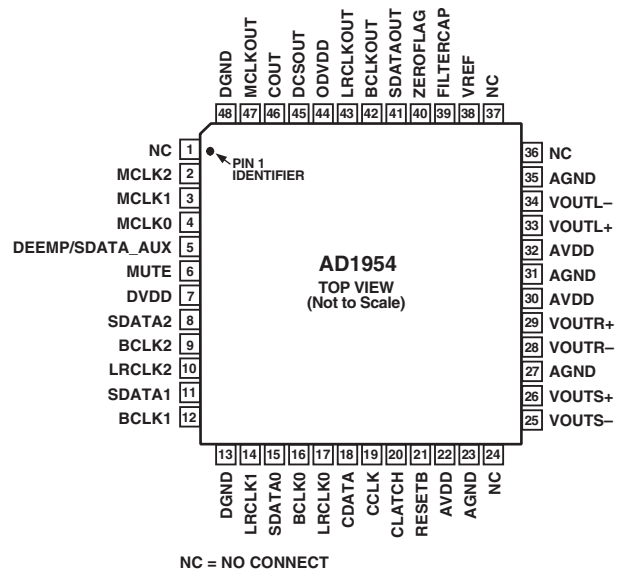

PIN FUNCTION DESCRIPTIONS

Pin No. (44-MQFP)	Pin No. (48-LQFP)	Mnemonic	Input/ Output	Description*
	1	NC		No Connect
1	2	MCLK2	IN	Master Clock Input 2 256 f _S /512 f _S
2	3	MCLK1	IN	Master Clock Input 1 256 f _S /512 f _S
3	4	MCLK0	IN	Master Clock Input 0 256 f _S /512 f _S
4	5	DEEMP/ SDATA_AUX	IN	Enables 44.1 kHz De-emphasis Filter (Others Available through SPI Control) Auxiliary Serial Data Input
5	6	MUTE	IN	Mute Signal. Initiates volume ramp-down.
6	7	DVDD		Digital Supply for DSP Core, 4.5 V to 5.5 V
7	8	SDATA2	IN	Serial Data Input 2
8	9	BCLK2	IN	Bit Clock 2
9	10	LRCLK2	IN	Left/Right Clock 2
10	11	SDATA1	IN	Serial Data Input 1
11	12	BCLK1	IN	Bit Clock 1
12	13	DGND		Digital Ground
13	14	LRCLK1	IN	Left/Right Clock 1
14	15	SDATA0	IN	Serial Data Input 0
15	16	BCLK0	IN	Bit Clock 0
16	17	LRCLK0	IN	Left/Right Clock 0
17	18	CDATA	IN	SPI Data Input
18	19	CCLK	IN	SPI Data Bit Clock
19	20	CLATCH	IN	SPI Data Framing Signal
20	21	RESETB	IN	Reset Signal, Active Low
21	22	AVDD		Analog 5 V Supply
22	23	AGND		Analog GND
	24	NC		No Connect
23	25	VOUTS-	OUT	Negative Sub Analog DAC Output
24	26	VOUTS+	OUT	Positive Sub Analog DAC Output
25	27	AGND		Analog GND
26	28	VOUTR-	OUT	Negative Left Analog DAC Output
27	29	VOUTR+	OUT	Positive Left Analog DAC Output
28	30	AVDD		Analog 5 V Supply
29	31	AGND		Analog GND
30	32	AVDD		Analog 5 V Supply
31	33	VOUTL+	OUT	Positive Left Analog DAC Output
32	34	VOUTL-	OUT	Negative Left Analog DAC Output
33	35	AGND		Analog GND
	36	NC		No Connect
	37	NC		No Connect
34	38	VREF	IN	Connection for Filtered AVDD/2
35	39	FILTCAP	IN	Connection for Noise Reduction Capacitor
36	40	ZEROFLAG	OUT	Zero Flag Output. High when both left and right channels are 0 for 1024 frames.
37	41	SDATAOUT	OUT	Serial Data Mux Output
38	42	BCLKOUT	OUT	Bit Clock Mux Output
39	43	LRCLKOUT	OUT	Left/Right Clock Mux Output
40	44	ODVDD		Digital Supply Pin for Output Drivers, 2.5 V to 5.5 V
41	45	DCSOUT	OUT	Data Capture Serial Output for Data Capture Registers. Use in conjunction with selected LRCLK and BCLK to form a 3-wire output.
42	46	COUT	OUT	SPI Data Output. Three-stated when inactive.
43	47	MCLKOUT	OUT	Master Clock Output 512 f _S /256 f _S (Frequency Selected by SPI Register)
44	48	DGND		Digital Ground

*For a complete description of the pins, refer to the Pin Functions section.

AD1954—Typical Performance Characteristics

PERFORMANCE PLOTS

The following plots demonstrate the performance achieved on the actual silicon. TPC 1 shows an FFT of a full-scale 1 kHz signal, with a THD+N of -100 dB, which is dominated by a second harmonic. TPC 2 shows an FFT of a -60 dB sine wave, demonstrating the lack of low-level artifacts. TPC 3 shows a frequency response plot with the seven equalization biquads set to an alternating pattern of 6 dB boosts and cuts. TPC 4 shows a linearity plot, where the measurement was taken with the same equalization curve used to make TPC 3. When the biquad filters are not in use, the signal passes through the filters with no quantization effects. TPC 4 therefore demonstrates that using double-precision math in the biquad filters has virtually eliminated any quantization artifacts. TPC 5 shows a tone-burst applied to the compressor, with the attack and recovery characteristics plainly visible. The rms detector was programmed for normal rms time constants; the hold/decay feature was not used for this plot.

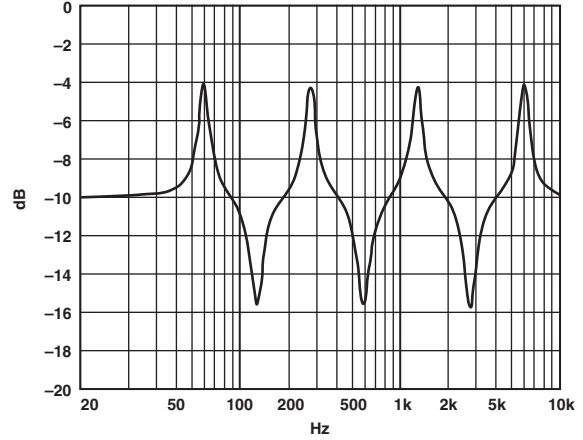

TPC 3. Frequency Response of EQ Biquad Filters

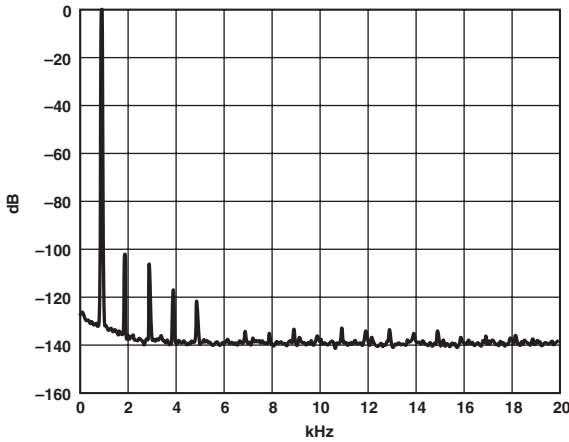

TPC 1. FFT of Full-Scale Sine Wave (32k Points)

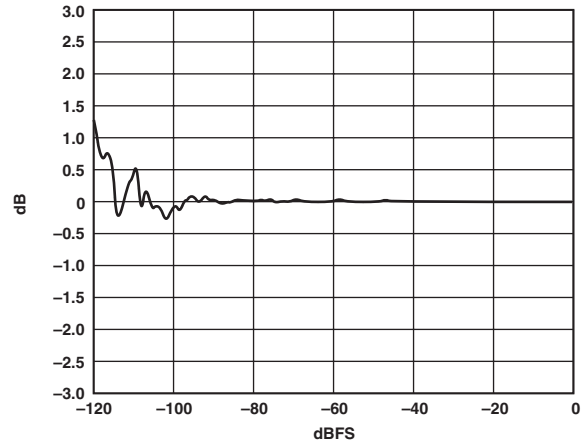

TPC 4. Linearity Plot

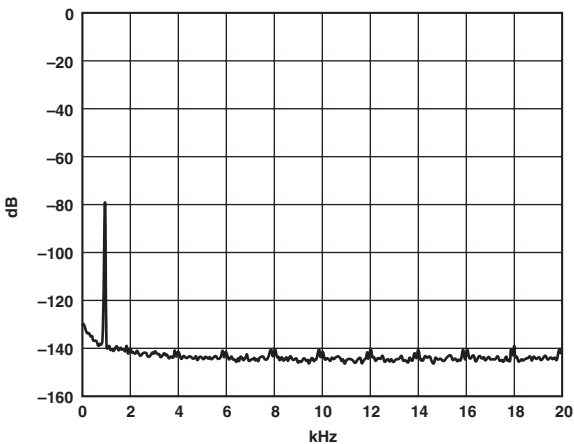

TPC 2. FFT of -60 dB Sine Wave (32k Points)

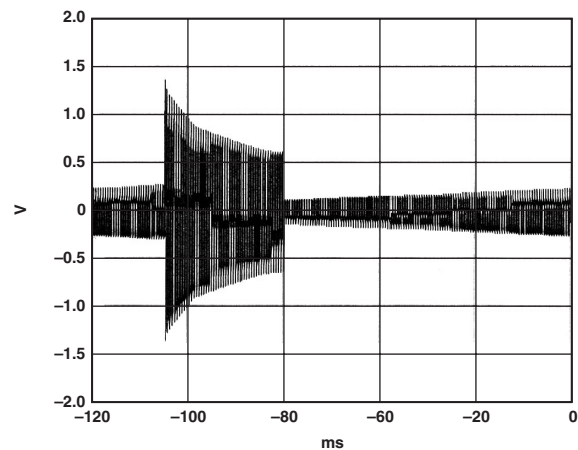

TPC 5. Tone-Burst Response with Compressor Threshold Set to -20 dB

GENERAL DESCRIPTION (continued from page 1)

An extensive SPI port allows click-free parameter updates, along with read-back capability from any point in the algorithm flow.

The AD1954 includes ADI's patented multibit Σ - Δ DAC architecture. This architecture provides 112 dB SNR and dynamic range and THD+N of -100 dB. These specifications allow the AD1954 to be used in applications ranging from low-end boom boxes to high-end professional mixing/editing systems.

The AD1954 also has a digital output that allows it to be used purely as a DSP. This digital output can also be used to drive an external DAC to extend the number of channels beyond the three that are provided on the chip.

This chip can be used with either its default signal processing program or with a custom user-designed program. Graphical programming tools are available from ADI for custom programming.

FEATURES

The AD1954 is comprised of a 26-bit DSP (48 bits with double precision) for interpolation and audio processing, three multibit Σ - Δ modulators, and analog output drive circuitry. Other features include an on-chip parameter RAM that uses a safe-upload feature for transparent and simultaneous updates of filter coefficients and digital de-emphasis filters. Also, on-chip input selectors allow up to three sources of serial data and master clock to be selected.

The 3-channel configuration is especially useful for 2.1 playback systems that include two satellite speakers and a subwoofer.

The default program allows for independent equalization and compression/limiting for the satellite and subwoofer outputs.

Figure 1 shows the block diagram of the device.

The AD1954 contains a program RAM that boots from an internal program ROM on power-up. Signal processing parameters are stored in a 256-location parameter RAM, which is initialized on power-up by an internal boot ROM. New values are written to the parameter RAM using the SPI port. The values stored in the parameter RAM control the IIR equalization filters, the dual-band compressor/limiter, the delay values, and the settings of the stereo spreading algorithm.

The AD1954 has a very sophisticated SPI port that supports complete read/write capability of both the program and the parameter RAM. Two control registers are also provided to control the chip serial modes and various other optional features. Handshaking is also included for ease of memory uploads/downloads.

The AD1954 contains four independent data capture circuits, which can be programmed to tap the signal flow of the processor at any point in the DSP algorithm flow. These captured signals can be accessed either through a separate serial out pin (i.e., that can be connected to an external DAC or DSP) or by reading from the data capture SPI registers. This allows the basic functionality of the AD1954 to be easily extended.

The processor core in the AD1954 has been designed from the ground up for straightforward coding of sophisticated compression/limiting algorithms. The AD1954 contains two independent compressor/limiters with rms based amplitude detection and attack/hold/release controls, together with an arbitrary compression curve that is loaded by the user into a look-up table that resides in the parameter RAM. The compressor also features look-ahead compression that prevents compressor overshoots.

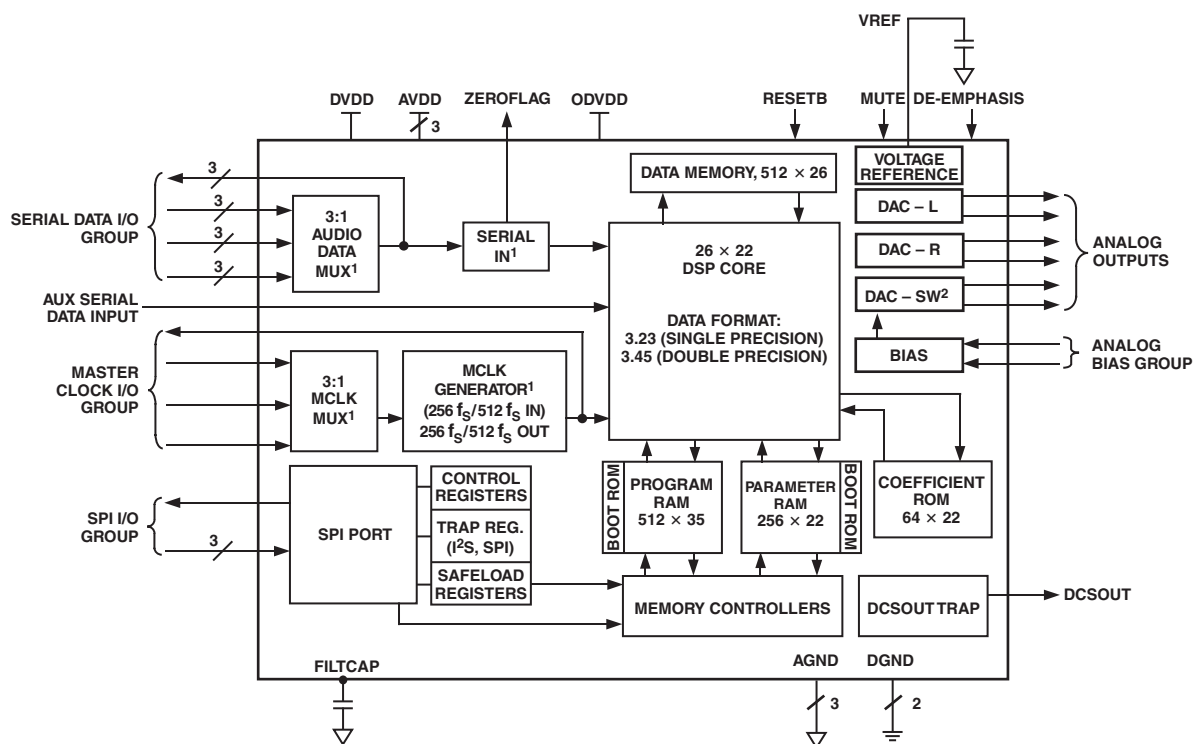
**NOTES**

¹CONTROLLED THROUGH SPI CONTROL REGISTERS.

²DAC DOES NOT USE DIGITAL INTERPOLATION.

Figure 1. Block Diagram

AD1954

The AD1954 has a very flexible serial data input port, which allows for glueless interconnection to a variety of ADCs, DSP chips, AES/EBU receivers, and sample rate converters. The AD1954 can be configured in left-justified, I²S, right-justified, or DSP serial port compatible modes. It can support 16 bits, 20 bits, and 24 bits in all modes. The AD1954 accepts serial audio data in MSB first, twos complement format. The part can also be set up in a 4-channel serial input mode by simultaneously using the serial input mux and the auxiliary serial input.

The AD1954 operates from a single 5 V power supply. It is fabricated on a single monolithic integrated circuit and is housed in a 44-lead MQFP or 48-lead LQFP package for operation over the temperature range -40°C to $+105^{\circ}\text{C}$.

PIN FUNCTIONS

All input pins have a logic threshold compatible with TTL input levels and can therefore be used in systems with 3.3 V logic. All digital output levels are controlled by the ODVDD pin, which may range from 2.7 V to 5.5 V, for compatibility with a wide range of external devices. (See Pin Function Descriptions table.)

SDATA0, SDATA1, SDATA2—Serial Data Inputs

One of these three inputs is selected by an internal mux, set by writing to Bits 7 and 6 in Control Register 2. Default is 00, which selects SDATA0. The serial format is selected by writing to Bits 3–0 of Control Register 0. See SPI Read/Write Data Formats section for recommendations on how to change input sources without causing a click or pop noise.

LRCLK0, LRCLK1, LRCLK2—Left/Right Clocks for Framing the Input Data

The active LRCLK input is selected by writing to Bits 7 and 6 in Control Register 2. The default is 00, which selects LRCLK0. The interpretation of the LRCLK changes according to the serial mode, set by writing to Control Register 0.

BCLK0, BCLK1, BCLK2—Serial Bit Clocks for Clocking in the Serial Data

The active BCLK input is selected by writing to Bits 7 and 6 in Control Register 2. Default is 00, which selects BCLK0. The interpretation of BCLK changes according to the serial mode, which is set by writing to Control Register 0.

LRCLKOUT, BCLKOUT, SDATAOUT—Output of Mux that Selects One of the Three Serial Input Groups

These pins may be used to send the selected serial input signals to other external devices. This output pin is enabled by writing a 1 to Bit 8 of Control Register 2. The default mode is 0 or Off.

MCLK0, MCLK1, MCLK2—Master Clock Inputs

Active input selected by writing to Bits 5 and 4 of Control Register 2. The default is 00, which selects MCLK0. The master clock frequency must be either $256 \times f_s$ or $512 \times f_s$, where f_s is the input sampling rate. The master clock frequency is programmed by writing to Bit 2 of Control Register 2. The default is 0 ($512 \times f_s$). See the Initialization section for recommendations concerning how to change clock sources without causing an audio click or pop. Note that since the default MCLK source pin is MCLK0, there must be a clock signal present on this pin on power-up so that the AD1954 can complete its initialization routine.

MCLKOUT—Master Clock Output

The master clock output pin may be programmed to produce either $256 \times f_s$, $512 \times f_s$, or a copy of the selected MCLK input pin. This pin is programmed by writing to Bits 1 and 0 of Control Register 2. The default is 00, which disables the MCLKO pin.

CDATA—Serial Data In for the SPI Control Port

See SPI Port section for more information on SPI port timing.

COUT—Serial Data Output

This is used for reading back registers and memory locations. It is three-stated when an SPI read is not active. See SPI Port section for more information on SPI port timing.

CCLK—SPI Bit Rate Clock

This pin either may run continuously or be gated off in between SPI transactions. See SPI Port section for more information on SPI port timing.

CLATCH—SPI Latch Signal

It must go low at the beginning of an SPI transaction and high at the end of a transaction. Each SPI transaction may take a different number of CCLKs to complete, depending on the address and read/write bit that are sent at the beginning of the SPI transaction. Detailed SPI timing information is given in SPI Port section.

RESETB—Active Low Reset Signal

After RESETB goes high, the AD1954 goes through an initialization sequence where the program and parameter RAMs are initialized with the contents of the on-board boot ROMs. All SPI registers are set to 0, and the data RAMs are also zeroed. The initialization is complete after 1024 MCLK cycles. Since the MCLK IN FREQ SELECT (Bit 2 in Control Register 2) defaults to $512 \times f_s$ at power-up, this initialization will proceed at the external MCLK rate and will take 1024 MCLK cycles to complete, regardless of the absolute frequency of the external MCLK. New values should not be written to the SPI port until the initialization is complete.

ZEROFLAG—Zero-Input Indicator

This pin will go high if both serial inputs have been inactive (zero data) for 1024 LRCLK cycles. This pin may be used to drive an external mute FET for reduced noise during digital silence. This pin also functions as a test out pin, controlled by the test register at SPI Address 511. While most Test Modes are not useful to the end user, one may be of some use. If the Test Register is programmed with the number 7 (decimal), the ZEROFLAG output will be switched to the output of the internal pseudo-random noise generator. This noise generator operates at a bit rate of $128 \times f_s$ and has a repeat time of once per 224 cycles. This mode may be used to generate white noise (or, with appropriate filtering, pink noise) to be used as a test signal for measuring speakers or room acoustics.

DCSOUT—Data Capture Serial Out

This pin will output the DSP's internal signals, which can be used by external DACs or other signal processing devices. The signals that are captured and output on the DCSOUT pin are controlled by writing program counter trap numbers to SPI Addresses 263 (for the left output) and 264 (for the right output). When the internal program counter contents are equal to the trap values written to the SPI port, the selected DSP register is transferred to the DCSOUT parallel-to-serial registers and shifted out on the DCSOUT pin. Table XX shows the program counter trap values and register-select values that should be used to tap various internal points of the algorithm flow.

The DCSOUT pin is meant to be used in conjunction with the LRCLK and BCLK signals that are provided to the serial input port. The format of DCSOUT is the same as the format used for the serial port. In other words, if the serial port is running in I²S mode, then the DCSOUT pin, together with the LRCLK0 and BCLK0 pins (assuming input 0 is selected), will form a valid 3-wire I²S output.

The DCSOUT pin can be used for a variety of purposes. If the DCSOUT pin is used to drive another external DAC, then a 4.1 system is possible using a new program downloaded into the program RAM.

DEEMP/SDATA_AUX—De-emphasis Input Pin/Auxiliary Serial Data Input

In de-emphasis mode, if this pin is asserted high, then a digital de-emphasis filter will be inserted into the signal flow. The de-emphasis curve is valid only for a sample rate of 44.1 kHz; curves for 32 kHz and 48 kHz may be programmed using the SPI port. This pin can also be used as an auxiliary 2-channel serial data input. This function is set by writing a 1 to Bit 11 of Control Register 1. The same clocks are used for this serial input as are used for the SDATA0, SDATA1, and SDATA2 signals. This serial input can only be used in the signal processing flow when using Analog Devices' custom programming tools; see the Graphical Custom Programming Tools section. The use of de-emphasis is still available while this pin is used as a serial input but only through SPI control.

MUTE—Mute Output Signal

When this pin is asserted high, a ramp sequence is started, which gradually reduces the volume to zero. When de-asserted, the volume ramps from zero back to the original volume setting. The ramp speed is timed so that it takes 10 ms to reach 0 volume when starting from the default 0 dB volume setting.

VOU_{TL+}, **VOU_{TL2}**—Left Channel Differential Analog Outputs

Full-scale outputs correspond to 1 V_{rms} on each output pin or 2 V rms differential, assuming a VREF input voltage of 2.5 V.

The full-scale swing scales directly with VREF. These outputs are capable of driving a load of >5 k Ω , with a maximum peak current of 1 mA from each pin. An external third order filter is recommended for filtering out-of-band noise.

VOU_{TR+}, **VOU_{TR2}** —Right Channel Differential Outputs

See characteristics for left channel VOU_{TL+}, VOU_{TL-}.

VOU_{TS+}, **VOU_{TS2}** —Subchannel Differential Outputs

These outputs are designed to drive loads of 10 k Ω or greater, with a peak current capability of 250 μ A. This output does not use digital interpolation, since it is intended for low frequency applications. An external third order filter with a cutoff frequency <2 kHz is recommended.

VREF—Analog Reference Voltage Input

The nominal VREF input voltage is 2.5 V; the analog gain scales directly with the voltage on this pin. When using the AD1954 to drive a power amplifier, it is recommended that the VREF voltage be derived by dividing down and heavily filtering the supply to the power amplifier. This provides a benefit if the compressor/limiter in the AD1954 is used to prevent amplifier clipping. In this case, if the DAC output voltage is scaled to the amplifier power supply, a fixed compressor threshold can be used to protect an amplifier whose supply may vary over a wide range. Any ac signal on this pin will cause distortion, and therefore, a large decoupling capacitor may be necessary to ensure that the voltage on VREF is clean. The input impedance of VREF is greater than 1 M Ω .

FILTCAP—Filter Capacitor Point

This pin is used to reduce the noise on an internal biasing point in order to provide the highest performance. It may not be necessary to connect this pin, depending on the quality of the layout and the grounding used in the application circuit.

DVDD—Digital VDD for Core

5 V nominal.

ODVDD—Digital VDD for All Digital Outputs

Variable from 2.7 V to 5.5 V.

DGND (2)—Digital Ground**AVDD (3)**—Analog VDD

5 V nominal. For best results, use a separate regulator for AVDD. Bypass capacitors should be placed close to the pins and connected directly to the analog ground plane.

AGND (3)—Analog Ground

For best performance, separate nonoverlapping analog and digital ground planes should be used.

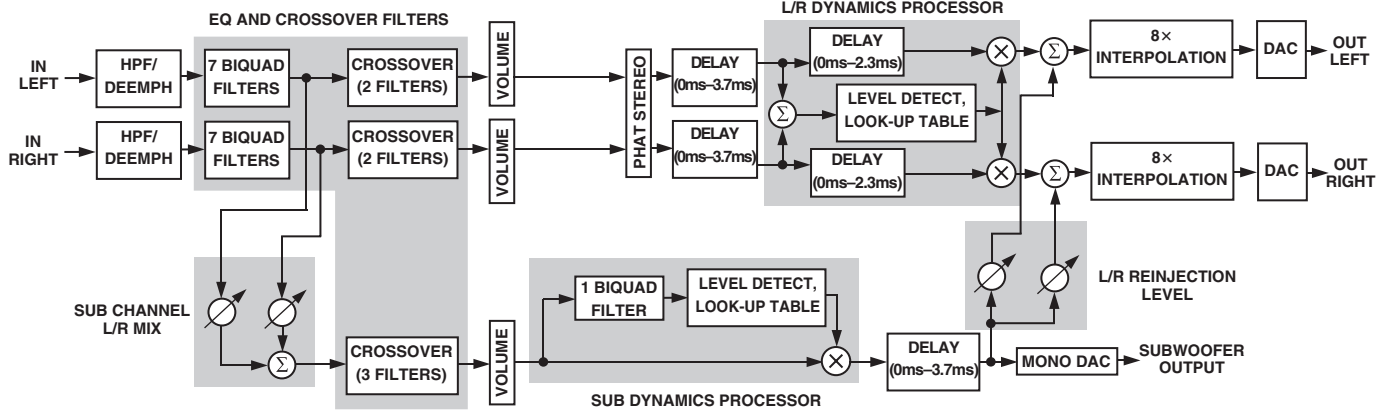

Figure 2. Signal Processing Flow

SIGNAL PROCESSING

Signal Processing Overview

Figure 2 shows the signal processing flow diagram of the AD1954. The AD1954 is designed to provide all the signal processing functions commonly used in 2.0 or 2.1 playback systems. A seven-biquad equalizer operates on the stereo input signal. The output of this equalizer is fed to a two-biquad crossover filter for the main channels, and the mono sum of the left and right equalizer outputs is fed to a three-biquad crossover filter for the subchannel. Each of the three channels has independent delay compensation. There are two high quality compressor/limiters available: one operating on the left/right outputs and one operating on the subwoofer channel. The subwoofer output may be blended back into the left/right outputs for 2.0 playback systems. In this configuration, the two independent compressor/limiters provide two-band compression, which significantly improves the sound quality of compressed audio. In addition, the main channels have a stereo widening algorithm that increases the perceived spread of the stereo image.

Most of the signal processing functions are coded using full 48-bit double-precision arithmetic. The input word length is 24 bits, with two extra headroom bits added in the processor to allow internal gains up to 12 dB without clipping (additional gains can be accommodated by scaling down the input signal in the first biquad filter section).

A graphical user interface (GUI) is available for evaluation of the AD1954 (Figure 3). This GUI controls all of the functions of the chip in a very straightforward and user friendly interface. No code needs to be written to use the GUI to control the chip. For more information on AD1954 software tools, send an e-mail to SigmaDSP@analog.com.

Each section of this flow diagram will be explained in detail on the following pages.

Numeric Formats

It is common in DSP systems to use a standardized method of specifying numeric formats. To better comprehend issues relating to precision and overflow, it is helpful to think in terms of fractional two's complement number systems. Fractional number systems are specified by an A.B format, where A is the number of bits to the left of the decimal point, and B is the number of bits to the right of the decimal point. In a two's complement system, there is also an implied offset of one-half of the binary range; for example, in a two's complement 1.23 system, the legal signal range is -1.0 to $+(1.0 - 1 \text{ LSB})$.

The AD1954 uses two different numeric formats: one for the coefficient values (stored in the parameter RAM) and one for the signal data values. The coefficient format is as follows:

Coefficient Format

Coefficient Format: 2.20

Range: -2.0 to $+(2.0 - 1 \text{ LSB})$

Examples:

10000000000000000000000000000000 = -2.0
 11000000000000000000000000000000 = -1.0
 11111111111111111111111111111111 = (1 LSB below 0.0)
 00000000000000000000000000000000 = 0.0
 01000000000000000000000000000000 = 1.0
 01111111111111111111111111111111 = $(2.0 - 1 \text{ LSB})$

This format is used because standard biquad filters require coefficients that range between $+2.0$ and -2.0 . It also allows gain to be inserted at various places in the signal path.

Internal DSP Signal Data Format

Input Data Format: 1.23

This is sign extended when written to the data memory of the AD1954.

Internal DSP Signal Data Format: 3.23

Range: -4.0 to $+(4.0 - 1 \text{ LSB})$

Examples:

10000000000000000000000000000000 = -4.0
 11000000000000000000000000000000 = -2.0
 11100000000000000000000000000000 = -1.0
 11111111111111111111111111111111 = (1 LSB below 0.0)
 00000000000000000000000000000000 = 0.0
 00100000000000000000000000000000 = 1.0
 01000000000000000000000000000000 = 2.0
 01111111111111111111111111111111 = $(4.0 - 1 \text{ LSB})$.

The sign extension between the serial port and the DSP core allows for up to 12 dB of gain in the signal path without internal clipping. Gains greater than 12 dB can be accommodated by scaling the input down in the first biquad filter and scaling the signal back up at the end of the biquad filter section.

A digital clipper circuit is used between the output of the DSP core and the input to the DAC Σ - Δ modulators to prevent overloading the DAC circuitry (see Figure 4). Note that there is a gain factor of 0.75 used in the DAC interpolation filters, and therefore signal values of up to $1/0.75$ will pass through the DSP without clipping. Since the DAC is designed to produce an analog output of 2V rms (differential) with a 0 dB digital input, signals between

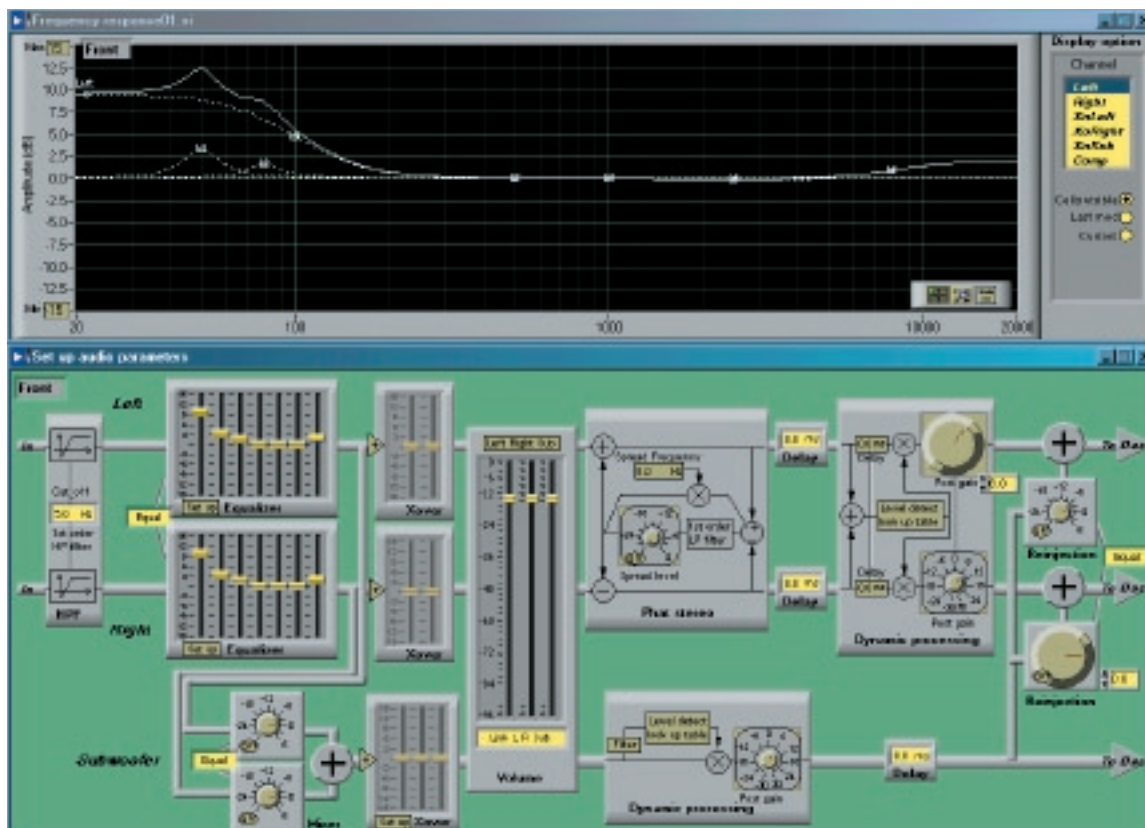

Figure 3. Graphical User Interface

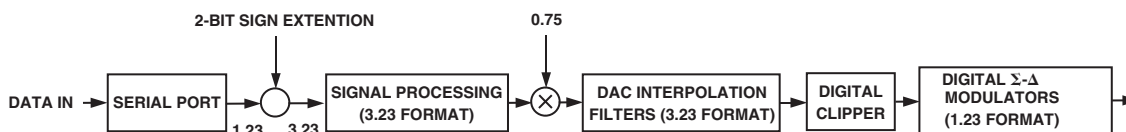

Figure 4. Numeric Precision and Clipping Structure

0 dB and 1/0.75 (approximately 3 dB) will produce larger analog outputs and result in slightly degraded analog performance. This extra analog range is necessary in order to pass 0 dBFS square waves through the system, since these square waves cause overshoots in the interpolation filters, which would otherwise briefly clip the digital DAC circuitry.

A separate digital clipper circuit is used in the DSP core to ensure that any accumulator values that exceed the numeric 3.23 format range are clipped when taken from the accumulator.

High-Pass Filter

The high-pass filter is a first order double-precision design. The purpose of the high-pass filter is to remove digital dc from the input. If this dc were allowed to pass, the detectors used in the compressor/limiter would give an incorrect reading for low signal levels. The high-pass filter is controlled by a single parameter (alpha_HPF), which is programmed by writing to SPI location 180 in 2.20 twos complement format. The following equation can be used to calculate the parameter alpha_HPF from the -3 dB point of the filter:

$$\text{Alpha_HPF} = 1.0 - \text{EXP}\left(\frac{-2.0 \times p \times \text{HPF_Cutoff}}{f_s}\right)$$

where EXP is the exponential operator, HPF_cutoff is the high-pass cutoff in Hz, and f_s is the audio sampling rate. The default value for the -3 dB cutoff of the high-pass filter is 2.75 Hz at a sampling rate of 44.1 kHz.

Biquad Filters

Each of the two input channels has seven second order biquad sections in the signal path. In addition, the left and right channels have two additional biquad filters that may be used either as crossover filters or as additional equalization filters. The subchannel has three additional biquad filters that are also to be used as equalization and/or crossover filters. In a typical scenario, the first seven biquads would be used for speaker equalization and/or tone controls, and the remaining filters would be programmed to function as crossover filters. Note that there is a common equalization section used for both the main and sub channels, followed by the crossover filters. This arrangement prevents any interaction from occurring between the crossover filters and the equalization filters. One section of the biquad IIR filter is shown in Figure 5.

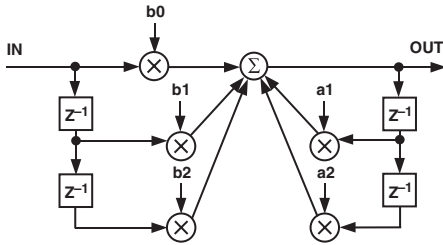

Figure 5. Biquad Filter

This section implements the transfer function:

$$H(Z) = \frac{(b0 + b1 \times Z^{-1} + b2 \times Z^{-2})}{(1 - a1 \times Z^{-1} - a2 \times Z^{-2})}$$

The coefficients a1, a2, b0, b1, and b2 are all in twos complement 2.20 format with a range from -2 to +2 (minus 1 LSB). The negative sign on the a1 and a2 coefficients is the result of adding both the feed-forward b terms as well as the feedback a terms. Some digital filter packages automatically produce the correct a1 and a2 coefficients for the topology of Figure 5, while others assume a denominator of the form 1 + a1 × Z⁻¹ + a2 × Z⁻¹. In this case, it may be necessary to invert the a1 and a2 terms for proper operation.

The biquad structure shown in Figure 5 is coded using double-precision math to avoid limit cycles from occurring when low frequency filters are used. The coefficients are programmed by writing to the appropriate location in the parameter RAM, through the SPI port (see Table VI). There are two possible scenarios for controlling the biquad filters:

1. Dynamic Adjustment (e.g., Bass/Treble Control or Parametric Equalizer).

When using dynamic filter adjustment, it is highly recommended that the user employ the safeload mechanism to avoid temporary instability when the filters are dynamically updated. This could occur if some, but not all, of the coefficients were updated to new values when the DSP calculates the filter output. The operation of the safeload registers is detailed in the Options for Parameter Updates section.

2. Setting Static EQ Curve after Power-Up.

If many of the biquad filters need to be initialized after power-up (e.g., to implement a static speaker correction curve), the recommended procedure is to set the processor shutdown bit, wait for the volume to ramp down (about 20 ms), and then write directly to the parameter RAM in burst mode. After the RAM is loaded, the shutdown bit can be de-asserted, causing the volume to ramp back up to the initial value. This entire procedure is click-free and faster than using the safeload mechanism.

The data paths of the AD1954 contain an extra two bits on top of the 24 bits that are input to the serial port. This allows up to 12 dB of boost without clipping. However, it is important to remember that it is possible to design a filter that has less than 12 dB of gain at the final filter output, but more than 12 dB of gain at the output of one or more intermediate biquad filter sections. For this reason, it is important to cascade the filter sections in the correct order, putting the sections with the largest peak gains at the end of the chain rather than at the beginning. This is standard practice when coding IIR filters and is covered in basic books on DSP coding.

If gains larger than 12 dB cannot be avoided, then the coefficients b0 through b2 of the first biquad section may be scaled down

to fit the signal into the 12 dB maximum signal range and then scaled back up at the end of the filter chain.

Volume

Three separate SPI registers are used to control the volume—one each for the left, right, and sub channels. These registers are special in that they include automatic digital ramp circuitry for clickless volume adjustment. The volume control word is in 2.20 format and therefore gains from +2.0 to -2.0 are possible. The default value is 1.0. It takes 1024 audio frames to adjust the volume from 2.0 down to 0; in the normal case where the maximum volume is set to 1.0, it will take 512 audio frames for this ramp to reach zero. Note that a mute command is the same as setting the volume to zero, except that when the part is un-muted, the volume returns to its original value.

These volume ramp times assume that the AD1954 is set for the fast volume ramp speed. If the slow setting is selected, it will take 8192 audio frames to reach zero from a setting of 2.0. Correspondingly, it will take 4096 frames to reach 0 volume from the normal setting of 1.0.

The volume blocks are placed after the biquad filter sections to maximize the level of the signal that is passed through the filter sections. In a typical situation, the nominal volume setting might be -15 dB, allowing a substantial increase in volume when the user increases the volume. The AD1954 was designed with an analog dynamic range of >112 dB, so that in the typical situation with the volume set to -15 dB, the signal-to-noise ratio at the output will still exceed 97 dB. Greater output dynamic ranges are possible if the compressor/limiter is used, since the post-compression gain parameter can boost the signal back up to a higher level. In this case, the compressor will prevent the output from clipping when the volume is turned up and the input signal is large.

Stereo Image Expander

The image enhancement processing is based on ADI’s patented Phat Stereo algorithm. The block diagram is shown in Figure 6.

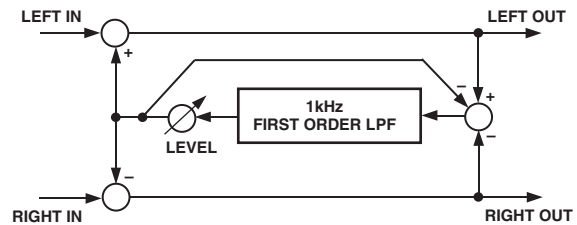

Figure 6. Stereo Image Expander

The algorithm works by increasing the phase shift for low frequency signals that are panned left or right in the stereo mix. Since the ear is responsive to interaural phase shifts below 1 kHz, this increase in phase shifts results in a widening of the stereo image. Note that signals panned to the center are not processed, resulting in a more natural sound. There are two parameters that control the Phat Stereo algorithm: the level variable, which controls how much out-of-phase information is added to the left and right channels, and the cutoff frequency of the first order low-pass filter, which determines the frequency range of the added out-of-phase signals. For best results, the cutoff frequency should be in the range of 500 Hz to 2 kHz. These parameters are controlled by altering the parameter RAM locations that store the parameters spread_level and alpha_spread. The spread_level is a linear number in 2.20 format that multiplies the processed left-right signal before it is added to or subtracted from the main channels. The parameter alpha_spread

is related to the cutoff frequency of the first order low-pass filter by the equation:

$$\text{Alpha_Spread} = 1.0 - \text{EXP} \left(\frac{-2.0 \times p \times \text{Spread_Freq}}{f_s} \right)$$

where *EXP* is the exponential operator, *Spread_Freq* is the low-pass cutoff in Hz, and *f_s* is the audio sampling rate.

Note that the stereo spreading algorithm assumes that frequencies below 1 kHz are present in the main satellite speakers. In some systems, the crossover frequency between the satellite and subwoofer speakers is quite high (>500 Hz). In such a case, the stereo spreading algorithm will not be effective, since the frequencies that contribute to the spreading effect will come mostly from the subwoofer, which is a mono source.

Delay

Each of the three DAC channels has a delay block that allows the user to introduce a delay of up to 165 audio samples. The delay values are programmed by entering the delay (in samples) into the appropriate location of the parameter RAM. With a 44.1 kHz sample rate, a delay of 165 samples corresponds to a time delay of 3.74 ms. Since sound travels at approximately 1 foot/ms, this can be used to compensate for speaker placements that are off by as much as 3.74 feet.

An additional 100 samples of delay are used in the look-ahead portion of the compressor/limiter but only for the main two channels. This can be used to increase the total delay for the left and right channels to 265 samples or 6 ms at 44.1 kHz.

Main Compressor/Limiter

The compressor used in the AD1954 is quite sophisticated and is comparable in many ways to the professional compressor/limiters used in the professional audio and broadcast fields. It uses rms/peak detection with adjustable attack/hold/release, look-ahead compression, and table-based entry of the input/output curve for complete flexibility.

The AD1954 uses two compressor/limiters: one in the subwoofer DAC and one in the main left/right DAC. It is well known that having independent compressors operating over different frequency ranges results in a superior perceived sound. With a single-band compressor, loud bass information will modulate the gain of the entire audio signal, resulting in suboptimal maximum perceived loudness as well as gain pumping or modulation effects. With independent compressors operating separately on the low and high frequencies, this problem is dramatically reduced. If the AD1954 is being operated in two-channel mode, an extra path is added so that the subwoofer channel can be added back into the main channel. This maintains the advantage of using a two-band compressor, even in a 2.0 system configuration.

Figure 7 shows the traditional basic analog compressor/limiter. It uses a voltage controlled amplifier to adjust gain and a feed-forward detector path using an rms detector with adjustable time constants, followed by a nonlinear circuit, to implement the desired input/output relationship. A simple compressor will have a single threshold above which the gain is reduced. The amount of compression above the threshold is called the compression ratio and is defined as dB change in input/dB change in output. For example, if the input to a 2:1 compressor is increased by 2 dB, the output will rise by 1 dB for signals above the threshold.

A single hard threshold results in more audible behavior than a so-called soft-knee compressor, where the compression is introduced more gradually. In an analog compressor, the soft-knee characteristic is usually made by using diodes in their exponential turn-on region.

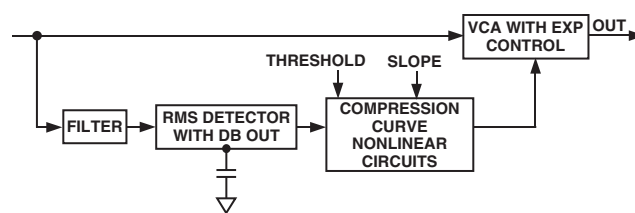

Figure 7. Analog Compressor

The best analog compressors use rms detection as the signal amplitude detector. The only class of detectors that is not sensitive to the phase of the harmonics in a complex signal are rms detectors. The ear also bases its loudness judgment on the overall signal power and therefore using an rms detector results in the best audible performance. Compressors that are based on peak detection, while good for preventing clipping, are generally quite poor for audible performance.

RMS detectors have a certain time constant that determines how rapidly they can respond to transient signals. There is always a trade-off between speed of response and distortion. Figure 8 shows this trade-off.

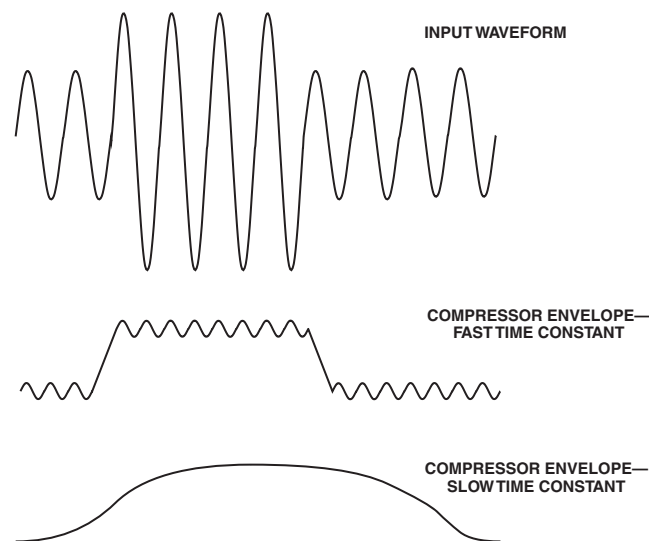

Figure 8. Effect of RMS Time Constant on Distortion

In the case of a fast-responding rms detector, the detector envelope will have a signal component in addition to the desired dc component. This signal component (which, for an rms detector, is at twice the input frequency) will result in harmonic distortion when multiplied by this detector signal.

The AD1954 uses a modified rms algorithm to improve the relationship between acquisition time and distortion. It uses a peak-riding circuit together with a hold circuit to modify the rms signal, as shown in Figure 9. This figure shows two envelopes. One has the harmonic distortion, as seen in the previous figure, and the other, flatter envelope is the one produced by the AD1954.

AD1954

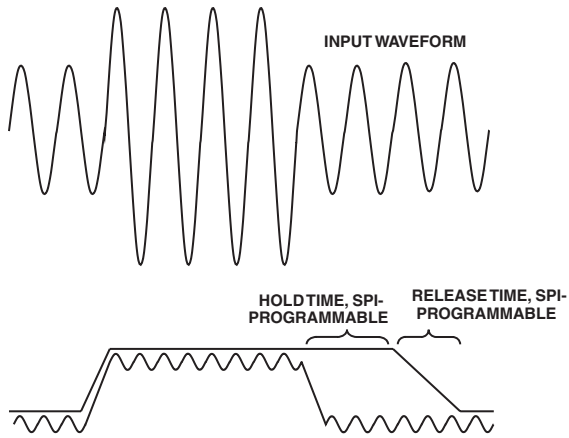

Figure 9. Using the Hold and Release Time Feature

Using this idea of a modified rms algorithm, the true rms value is still obtained for all but the lowest frequency signals, while the distortion due to rms ripple is reduced. It also allows the user to set the hold and release times of the compressor independently.

The detector path of the AD1954 is shown in Figure 10. The rms detector is controlled by three parameters stored in the parameter RAMs: the rms time constant, the hold time, and the release rate. The log output of the rms detector is applied to a look-up table with interpolation. The higher bits of the rms output form an offset into this table, and the lower bits are used to interpolate between the table entries to form a high-precision gain word. The look-up table resides in the parameter RAM and is loaded by the user to give the desired curve. The look-up table contains 33 data locations, and the LSB of the address into the look-up table corresponds to a 3 dB change in the amplitude of the detector signal. This gives the user the ability to program an input/output curve over a 99 dB range. For the main compressor, the table resides in Locations 110 to 142 in the SPI parameter RAM.

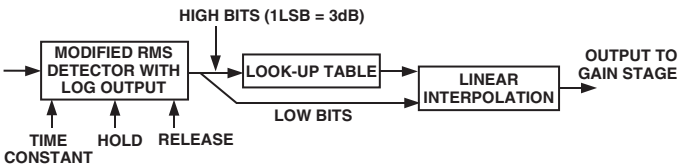

Figure 10. Gain Derived from Interpolated Look-Up Table

One subtlety of the look-up table involves the difference between the rms value of a sine wave and that of a square wave. If a full-scale square wave is applied to the AD1954, the rms value of this signal will be 3 dB higher than the rms value of a 0 dBFS sine wave. Therefore, the table ranges from +9 dB (Location 142) to -87 dB (Location 110).

The entries in the table are linear gain words in 2.20 format. Figure 11 shows an example of the table entries for a simple above-threshold compressor.

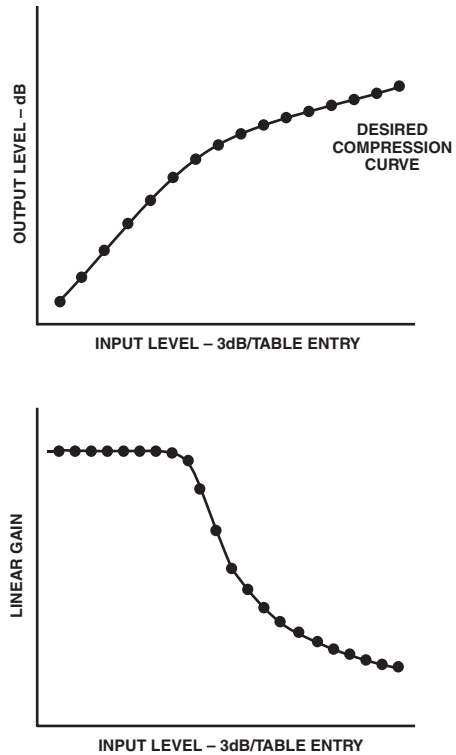

Figure 11. Example of Table Entry for a Given Compression Curve

Note that the maximum gain that can be entered in the table is 2.0 (minus 1 LSB). If more gain is required, the entire compression curve may be shifted upward by using the post-compression gain block following the compressor/limiter.

The AD1954 compressor/limiter also includes a look-ahead compression feature. The idea behind look-ahead compression is to prevent compressor overshoots by applying some digital delay to the signal before the gain-control multiplier but not to the detector path. In this way, the detector can acquire the new amplitude of the input signal before the signal actually reaches the multiplier. A comparison of a tone burst fed to a conventional compressor versus a look-ahead compressor is shown in Figure 12.

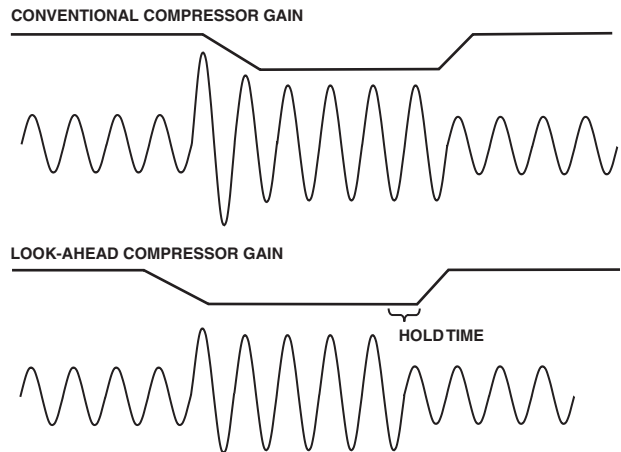

Figure 12. Conventional Compression vs. Look-Ahead Compression

In the look-ahead compressor, the gain has already been reduced by the time that the tone-burst signal arrives at the multiplier input. Note that when using a look-ahead compressor, it is important to set the detector hold time to a value that is at least the same as the look-ahead delay time or the compressor release will start too soon, resulting in an expanded tail of a tone-burst signal. The complete flow of the left/right dynamics processor is shown in Figure 13.

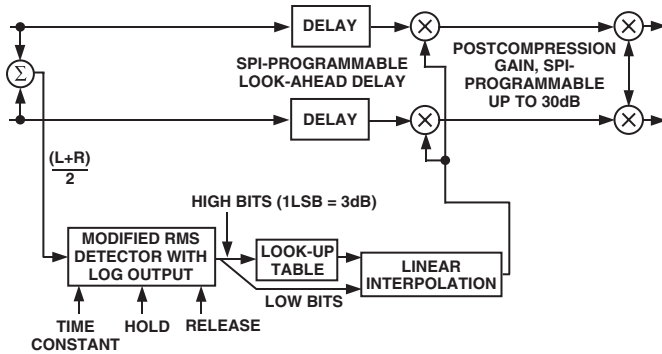

Figure 13. Complete Dynamics Flow, Main Channels

The detector path works from the sum of the left and right channels ((L + R)/2). This is the normal way that compressors are built and counts on the fact that the main instruments in any stereo mix are seldom recorded deliberately out of phase, especially in the lower frequencies that tend to dominate the energy spectrum of real music.

The compressor is followed by a block known as post-compression gain. Most compressors are used to reduce the dynamic range of music by lowering the gain during loud signal passages. This results in an overall loss of volume. This loss can be made up by introducing gain after the compressor. In the AD1954, the coefficient format used is 2.20, which has a maximum floating-point representation of slightly less than 2.0. This means that the maximum gain that can be achieved in a single instruction is 6 dB. To get more gain, the program in the AD1954 uses a cascade of five multipliers to achieve up to 30 dB of post-compression gain.

To program the compressor/limiter, the following formulas may be used to determine the 22-bit numbers (in 2.20 format) to be entered into the parameter RAM.

RMS Time Constant

This can be best expressed by entering the time constant in terms of dB/sec raw release rate (without the peak-riding circuit). The attack rate is a rather complicated formula that depends on the change in amplitude of the input sine wave.

$$rms_tconst_parameter = 1.0 - 10^{\left(\frac{release_rate}{10.0 \times f_s}\right)}$$

where *rms_tconst_parameter* = the fractional number to enter into the SPI RAM (after converting to 22-bit 2.20 format), and the *release_rate* = the *release rate* of the raw rms detector in dB/sec. This must be negative, and *f_s* = the audio sample rate.

RMS Hold Time

$$rms_hold_time_parameter = int(f_s \times hold_time)$$

Where *rms_holdtime_parameter* = the integer number to enter into the SPI RAM, *f_s* = the audio sample rate, *hold_time* = the absolute time to wait before starting the release ramp-down of the detector output, and *int()* = the integer part of the expression.

RMS Release Rate

$$rms_decay_parameter = int(rms_decay / 0.137)$$

where *rms_decay_parameter* = the decimal integer number to enter into the SPI RAM, *rms_decay* = the decay rate in dB/sec, and *int()* = the integer part of the expression.

Look-Ahead Delay

$$lookahead_delay_parameter = lookahead_delay \times f_s$$

where *lookahead_delay* = the predictive compressor delay in absolute time, *f_s* = the audio sample rate, and the maximum *lookahead_delay_parameter* value is 100.

Postcompression Gain

$$post_compression_gain_parameter = post_compression_gain_linear^{(1/5)}$$

where *post_compression_gain_linear* is the linear post-compression gain and ^ = the raise to the power.

Subwoofer Compressor/Limiter

The subwoofer compressor/limiter differs from the left/right compressor in the following ways:

1. The subwoofer compressor operates on a weighted sum of the left and right inputs (aa × Left + bb × Right), where aa and bb are both programmable.
2. The detector input has a biquad filter in series with the input in order to implement frequency-dependent compression thresholds.
3. There is no predictive compression since presumably the input signals are filtered to pass only low frequencies and therefore transient overshoots are not a problem.

The subwoofer compressor signal flow is shown in Figure 14.

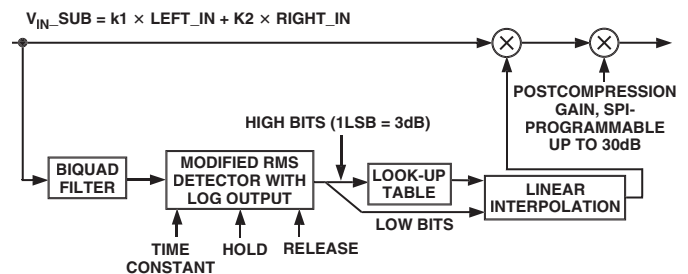

Figure 14. Signal Flow for Subwoofer Compressor

AD1954

The biquad filter before the detector can be used to implement a frequency-dependent compression threshold. For example, assume that the overload point of the woofer is very frequency dependent. In this case, one would have to set the compressor threshold to a value that corresponded to the most sensitive overload frequency of the woofer. If the input signal happened to be mostly in a frequency range where the woofer was not so sensitive to overload, then the compressor would be too pessimistic and the volume of the woofer would be reduced. If, on the other hand, the biquad filter were designed to follow the woofer excursion curve of the speaker, then the volume of the woofer could be maximized under all conditions. This is illustrated in Figure 15.

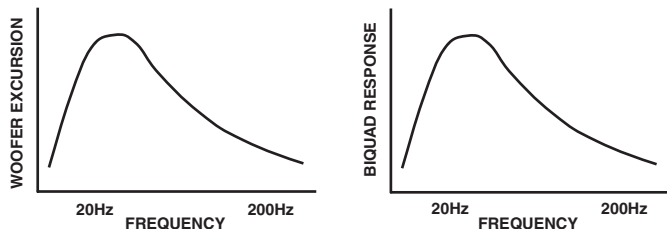

Figure 15. Optimizing Woofer Loudness Using the Subwoofer rms Biquad Filter

When using a filter in front of the detector, a confusing side effect occurs. If one measures the frequency response by using a swept sine wave with an amplitude large enough to be above the compressor threshold, the resulting frequency response will not look flat. However, this is not real in the sense that, as the sine wave is swept through the system, the gain is being slowly modulated up and down according to the response of the biquad filter in front of the detector. If one measures the response using a pink noise generator, the result will look much better, since the detector will settle on only one gain value. The perceptual effect of the swept sine wave test is not at all what would be predicted by simply looking at the frequency response curve; it is only the signal path filters that will affect the perception of the frequency response, not the detector path filters.

De-emphasis Filtering

The standard for encoding CDs allows the use of a pre-emphasis curve during encoding, which must be compensated for by a de-emphasis curve during playback. The de-emphasis curve is defined as a first order shelving filter with a single pole at $(1/(2 \times \pi \times 50 \mu\text{s}))$ followed by a single zero at $(1/(2 \times \pi \times 15 \mu\text{s}))$. This curve may be accurately modeled using a first order digital filter. This filter is included in the AD1954; it is not part of the bank of biquad filters and so does not take away from the number of available filters.

Since the specification of the de-emphasis filter is based on an analog filter, the response of the filter should not depend on the

incoming sampling rate. However, when the de-emphasis filter is implemented digitally, the response will scale with the sampling rate unless the filter coefficients are altered to suit each possible input sampling rate. For this reason, the AD1954 includes three separate de-emphasis curves: one each for sampling rates of 32 kHz, 44.1 kHz, and 48 kHz. These curves are selected by writing to Bits 5 and 4 of Control Register 1 over the SPI port. Alternatively, the 44.1 kHz curve can be called upon using the DEEMP/SDATA_AUX pin. This pin is included for compatibility with CD decoder chips that have a de-emphasis output pin.

Using the Sub Reinjection Paths for Systems with No Subwoofer

Many systems will not use a subwoofer but would still benefit from two-band compression/limiting. This can be accommodated by using sub reinjection paths in the program flow. These parameters are programmed by entering two numbers (in 2.20 format) into the parameter RAM. Note that if the biquad filters are not properly designed, the frequency response at the crossover point may not be flat. Many crossover filters are designed to be flat in the sense of adding the powers together, but nonflat if the sum is done in voltage mode. The user must take care to design an appropriate set of crossover filters.

Interpolation Filters

The left and right channels have a 128:1 interpolation filter with 70 dB stop-band attenuation that precedes the digital Σ - Δ modulator. This filter has a group delay of approximately $24.1875/f_s$ taps, where f_s is the sampling rate. The sub channel does not use an interpolation filter. The reason for this (besides saving valuable MIPS) is that it is expected that the bandwidth of the sub output will be limited to less than 1 kHz. With no interpolation filter, the first image will therefore be at 43.1 kHz (which is $f_s - 1$ kHz for CD audio). The standard external filter used for both the main and sub channels is a third order, single op amp filter. If the cut-off frequency of the external subwoofer filter is 2 kHz, then there are more than four octaves between 2 kHz and the first image at 43.1 kHz. A third order filter will roll off by approximately $18 \text{ dB/oct} \times 4 \text{ octaves} = 72 \text{ dB}$ attenuation. This is approximately the same as the digital attenuation used in the main channel filters, so no internal interpolation filter is required to remove the out-of-band images.

Note that by having interpolation filters in the main channels but not the subwoofer channel, there is a potential time-delay mismatch between the main and sub channels. The group delay of the digital interpolation filters used in the main left/right channels is about 0.5 ms. This must be compared to the group delay of the external analog filter used in the subwoofer path. If the group-delay mismatch causes a frequency response error (when the two signals are acoustically added), then the programmable delay feature can be used to put extra delay in either the subwoofer path or the main left/right path.

SPI PORT

Overview

The AD1954 has many different control options. Most signal processing parameters are controlled by writing new values to the parameter RAM using the SPI port. Other functions, such as volume and de-emphasis filtering, are programmed by writing to the SPI control registers.

The SPI port uses a 4-wire interface, consisting of CLATCH, CCLK, CDATA, and COUT signals. The CLATCH signal goes low at the beginning of a transaction and high at the end of a transaction. The CCLK signal latches the serial input data on a low-to-high transition. The CDATA signal carries the serial input data, and the COUT signal is the serial output data. The COUT signal remains three-stated until a read operation is requested. This allows other SPI compatible peripherals to share the same readback line.

The SPI port is capable of full read/write operation for all of the memories (parameter and program) and some of the SPI registers (Control Register 1 and the data capture registers). The memories may be accessed in both a single address mode or in burst mode. All SPI transactions follow the same basic format that is shown in Table I.

Table I. SPI Word Format

Byte 0	Byte 1	Byte 2	Byte 3	Byte 4
00000, R/ \bar{W} , Addr[9:8]	Addr[7:0]	Data	Data	Data

The R/ \bar{W} bit is low for a write and high for a read operation.

The 10-bit address word is decoded into either a location in one of the two memories (parameter or program) or one of the SPI registers. The number of data bytes varies according to the register or memory being accessed. In burst-write mode (available for loading the RAMs only), an initial address is given followed by a continuous sequence of data for consecutive RAM locations. The detailed data format diagram for continuous-mode operation is given in SPI read/write data formats.

A sample timing diagram for a single SPI write operation to the parameter RAM is shown in Figure 16.

A sample timing diagram of a single SPI read operation is shown in Figure 17. The COUT pin goes from three-state to driven at the beginning of Byte 2. Bytes 0 and 1 contain the address and R/ \bar{W} bit, and Bytes 2 through 4 carry the data. The exact format is shown in Tables VIII to XIX.

The AD1954 has several mechanisms for updating signal-processing parameters in real time without causing loud pops or clicks. In cases where large blocks of data need to be downloaded, the DSP core can be shut down and new data loaded, and then the core can be restarted. The shutdown and restart mechanisms employ a gradual volume ramp to prevent clicks and pops. In cases where only a few parameters need to be changed (e.g., a single biquad filter), a safeload mechanism is used, which allows a block of SPI registers to be transferred to the parameter RAM within a single audio frame while the core is running. The safeload mode uses internal logic to prevent contention between the DSP core and the SPI port.

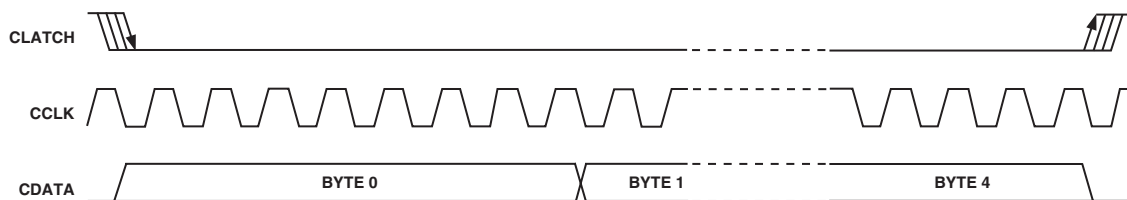

Figure 16. Sample of SPI Write Format (Single-Write Mode)

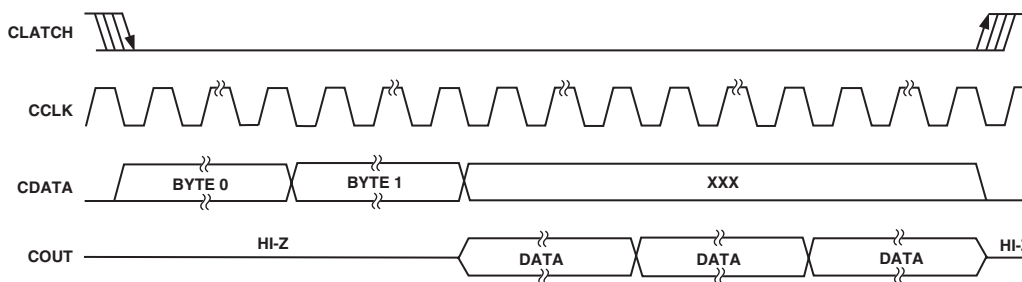

Figure 17. Sample of SPI Read Format (Single-Write Mode)

Table II. SPI Port Address Decoding

SPI Address	Register Name	Read/Write Word Length
0–255	Parameter RAM	Write: 22 Bits Read: 22 Bits
256	SPI Control Register 1	Write: 11 Bits Read: 2 Bits
257	SPI Control Register 2	Write: 9 Bits Read: N/A
258	Volume Left	Write: 22 Bits Read: N/A
259	Volume Right	Write: 22 Bits Read: N/A
260	Volume Sub	Write: 22 Bits Read: N/A
261	Data Capture (SPI Out) #1	Write: 9-Bit Program Counter Value, 2-Bit Register Address Read: 24 Bits
262	Data Capture (SPI Out) #2	Write: 9-Bit Program Counter Value, 2-Bit Register Address Read: 24 Bits
263	Data Capture (Serial Out) Left	Write: 9-Bit Program Counter Value, 2-Bit Register Address Read: N/A
264	Data Capture (Serial Out) Right	Write: 9-Bit Program Counter Value, 2-Bit Register Address Read: N/A
265	Parameter RAM Safe Load Register 0	Write: 8-Bit Parameter RAM Address, 22-Bit Parameter Data Read: N/A
266	Parameter RAM Safe Load Register 1	Write: 8-Bit Parameter RAM Address, 22-Bit Parameter Data Read: N/A
267	Parameter RAM Safe Load Register 2	Write: 8-Bit Parameter RAM Address, 22-Bit Parameter Data Read: N/A
268	Parameter RAM Safe Load Register 3	Write: 8-Bit Parameter RAM Address, 22-Bit Parameter Data Read: N/A
269	Parameter RAM Safe Load Register 4	Write: 8-Bit Parameter RAM Address, 22-Bit Parameter Data Read: N/A
270–510	Unused	
511	Test Register	Write: 8 Bits Read: N/A
512–1024	Program RAM	Write: 35 Bits Read: 35 Bits

SPI Address Decoding

Table II shows the address decoding used in the SPI port. The SPI address space encompasses a set of registers and two RAMs, one for holding signal processing parameters and one for holding the program instructions. Both of the RAMs are loaded on power-up from on-board boot ROMs.

Control Register 1

Control Register 1 is an 11-bit register that controls data capture, serial modes, de-emphasis, mute, power-down, and SPI-to-memory transfers. Table III documents the contents of this register. Table IV details the two bits in the register's read operation.

Bits 1:0 set the word length, which is used in right-justified serial modes to determine where the MSB is located relative to the start of the audio frame.

Bits 3:2 select one of four serial modes, which are discussed in the Serial Data Input Port section.

The de-emphasis curve selection Bits 5:4 turn on the internal de-emphasis filter for one of three possible sample rates.

Bit 6, the soft power-down bit, stops the internal clocks to the DSP core, but does not reset the part. The digital power consumption is reduced to a low level when this bit is asserted. Reset can only be asserted using the external reset pin.

Soft mute (Bit 7) is used to initiate a volume ramp-down sequence. If the initial volume was set to 1.0, this operation will take 512 audio frames to complete. When this bit is de-asserted, a ramp-up sequence is initiated until the volume returns to its original setting.

When set, Bit 8 enables the DCSOUT pin. This must be set in order to read from the data capture serial out registers.

The initiate-safe-transfer Bit 9 will request a data transfer from the SPI safeload registers to the parameter RAM. The safeload registers contain address-data pairs, and only those registers that have been written to since the last transfer operation will be uploaded. The user may poll for this operation to complete by reading Bit 0 of Control Register 1. The Safeload Mechanism section goes into more detail on this feature.

Bit 10, the halt program bit, is used to initiate a volume ramp-down followed by a shutdown of the DSP core. The user may poll for this operation to complete by reading Bit 1 of Control Register 1.

Bit 11 sets the function of the de-emphasis/auxiliary serial input pin. When this bit is set to 1, the pin will function as an auxiliary serial input that is clocked by the input mux's selected clocks. When set to 0, this pin enables the 44.1 kHz de-emphasis curve.

Table III. Control Register 1 Write Definition

Register Bits	Function
11	De-emphasis/Auxiliary Serial Input Pin Select (1 = Auxiliary Serial Input)
10	Halt Program (1 = Halt)
9	Initiate Safe Transfer (1 = Transfer)
8	Enable DCSOUT Output Pin (1 = Enable)
7	Soft Mute (1 = Start Mute Sequence)
6	Soft Power-Down (1 = Power-Down)
5:4	De-emphasis Curve Select 00 = None 01 = 44.1 kHz 10 = 32 kHz 11 = 48 kHz
3:2	Serial in Mode 00 = I ² S 01 = Right-Justified 10 = DSP 11 = Left-Justified
1:0	Word Length 00 = 24 Bits 01 = 20 Bits 10 = 16 Bits 11 = 16 Bits

Table IV. Control Register 1 Read Definition

Register Bits	Function
1	DSP Core Shutdown Complete 1 = Shutdown Complete 0 = Not Shut Down
0	Safe Memory Load Complete 1 = Complete (Note: Cleared after Read) 0 = Not Complete

Bit 0 is asserted when all requested safeload registers have been transferred to the parameter RAM. It is cleared after the read operation is complete.

Bit 1 is asserted after the requested shutdown of the DSP is completed. When this bit is set, the user is free to write or read any RAM location without causing an audio pop or click.

Table V. Control Register 2 Write Definition

Register Bits	Function
9	Volume Ramp Speed 1 = 160 ms Full Ramp Time 0 = 20 ms Full Ramp Time
8	Serial Port Output Enable 1 = Enabled 0 = Disabled
7:6	Serial Port Input Select 00 = IN0 01 = IN1 10 = IN2 11 = NA
5:4	MCLK Input Select 00 = MCLK0 01 = MCLK1 10 = MCLK2 11 = NA
3	Reserved
2	MCLK in Frequency Select 0 = $512 \times f_S$ 1 = $256 \times f_S$
1:0	MCLK Out Frequency Select 00 = Disabled 01 = $512 \times f_S$ 10 = $256 \times f_S$ 11 = MCLK_Out = MCLK_In (Feedthrough)

Control Register 2

Table V documents the contents of Control Register 2. Bits 1 and 0 set the frequency of the MCLKOUT pin. If these bits are set to 00, then the MCLKOUT pin is disabled (default). When set to 01, the MCLKOUT pin is set to $512 \times f_S$, which is the same as the internal master clock used by the DSP core. When set to 10, this pin is set to $256 \times f_S$, derived by dividing the internal DSP clock by 2. In this mode, the output $256 f_S$ clock will be inverted with respect to the input $256 f_S$ clock. This is not the case with the feedthrough mode. When set to 11, the MCLKOUT pin mirrors the selected MCLK input pin (it's the output of the MCLK mux selector). Note that the internal DSP master clock may either be the same as the selected MCLK pin (when MCLK frequency select is set to $512 \times f_S$ mode) or may be derived from the MCLK pin using an internal clock doubler (when MCLK frequency select is set to $256 \times f_S$).

Bit 2 selects one of two possible MCLK input frequencies. When set to 0 (default), the MCLK frequency is set to $512 \times f_S$. In this mode, the internal DSP clock and the external MCLK are at the same frequency. When set to 1, the MCLK frequency is set to $256 \times f_S$, and an internal clock doubler is used to generate the DSP clock.

Bits 5 and 4 select one of three clock input sources using an internal mux. To avoid click and pop noises when switching MCLK sources, it is recommended that the user put the DSP core in shutdown before switching MCLK sources.

Bits 7 and 6 select one of three serial input sources using an internal mux. Each source selection includes a separate SDATA, LRCLK, and BCLK input. To avoid click and pop noises when switching serial sources, it is recommended that the user put the DSP core in shutdown before writing to these bits.

AD1954

Bit 8 is used to enable the three serial output pins. These pins are connected to the output of the serial input mux, which is set by Bits 7 and 6. The default is 0 (disabled).

Bit 9 changes the default setting of the volume ramp speed. When set to 0, it will take 1024 LRCLK periods to go from full volume (6 dB) to infinite attention. When set to 1, the same operation will take 8192 LRCLK periods.

Volume Registers

The AD1954 contains three 22-bit volume registers: one each for the left, right, and subwoofer channels. These registers are special because when the volume is changed from an initial value to a new value, a linear ramp is used to interpolate between the two values. This feature prevents audible clicks and pops when changing volume. The ramp is set so that it takes 512 audio frames to decrement from a volume of 1.0 (default) down to 0 (muted). The volume registers are formatted in 2.20 twos complement, meaning that 0100000000000000000000 is interpreted as 1.0. Negative values can also be written to the volume register, causing an inversion of the signal. Negative values work as expected with the ramp feature; to go from +1.0 to -1.0 will take 1024 LRCLKs, and the volume will pass through 0 on the way.

Parameter RAM Contents

Table VI shows the contents of the parameter RAM for the AD1954's default program. The parameter RAM is 22 bits wide and occupies SPI Addresses 0 through 255. The low addresses of the RAM are used to control the biquad filters. There are 22 biquad filters in all, and each biquad has five coefficients, resulting in a total memory usage of 110 coefficients. There are also two tables of 33 coefficients, each that define the main and subcompressor input/output characteristics. These are loaded with 1.0 on power-up, resulting in no compression. Other RAM entries control other compressor characteristics, as well as delay and spatialization settings.

The parameter RAM is initialized on power-up by an on-board boot ROM. The default values yield no equalization, no compression, no spatialization, no delay, and normal detector time constants in the compressor sections. The functionality of the AD1954 on power-up is basically that of a normal audio DAC with no signal processing capability.

The data format of the parameter RAM is twos complement 2.20 format. This means that the coefficients may range from +2.0 (-1 LSB) to -2.0, with 1.0 represented by the binary word 0100000000000000000000.

Options for Parameter Updates

The parameter and program RAMs can be written and read using one of several methods.

1. Direct read/write. This method allows direct access to the RAMs. Since the RAMs are also being used during real-time DSP operation, a glitch will likely occur at the output. This method is not recommended.
2. Direct read/write after core shutdown. This method avoids the glitch while accessing the internal RAMs by first shutting down the core. This is recommended for transferring large amounts of data, such as initializing the parameter RAM at power-up or downloading a completely new program. These transfers can be sped up by using burst mode, where an initial address followed by blocks of data are sent to the RAM.
3. Safeload writes. This is where up to five SPI registers are loaded with address/data intended for the parameter RAM. The data is then transferred to the requested address when the RAM is not busy. This method can be used for dynamic updates while live program material is playing through the AD1954. For example, a complete update of one biquad section can occur in one audio frame while the RAM is not busy. This method is not available for writing to the program RAM or control registers.

The next section discusses these options in more detail.

Soft Shutdown Mechanism

When writing large amounts of data to the program or parameter RAM, the processor core should be halted to prevent unpleasant noises from appearing at the audio output. Figure 18 shows a graphical representation of this mechanism's volume envelope. Points A through D are referenced in the following description. Bit 10 in Serial Control Register 0 (processor shutdown bit) will shut down the processor core. When the processor shutdown bit is asserted (A), an automatic volume ramp-down sequence (B) lasting from 10 ms to 20 ms will occur, followed by a shutdown of the core. This method of shutting down the core prevents pops or clicks from occurring. After the shutdown is complete, Bit 1 in Control Register 1 will be set. The user can either poll for this bit to be set or just wait for a period longer than 20 ms.

Once the core is shut down (C), the parameter or program RAMs may be written or read freely. To facilitate the transfer of large blocks of sequential data, a block transfer mode is supported where a starting address followed by a stream of data is sent to the memory. The address into the memory will be automatically incremented for each new write. This mode is documented in the SPI Read/Write Data Formats section of this data sheet.

Once the data has been written, the shutdown bit can be cleared (D). The processor then will initiate a volume ramp-up sequence

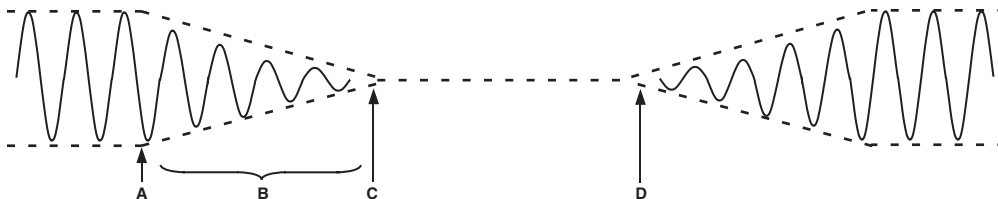

Figure 18. Recommended Sequences for Complete Parameter or Program RAM Uploaded Using Shutdown Mechanism

Table VI. Parameter RAM Contents—Default Program

Addr	Function	Default Value in Fractional 2.20 Format	Addr	Function	Default Value in Fractional 2.20 Format	Addr	Function	Default Value in Fractional 2.20 Format
0	IIR0 Left b0	1.0	54	IIR3 Right a2	0	108	IIR Sub rms a1	0
1	IIR0 Left b1	0	55	IIR4 Right b0	1.0	109	IIR Sub rms a2	0
2	IIR0 Left b2	0	56	IIR4 Right b1	0	110–142	Main Compressor Look-Up Table Base	1.0 (all)
3	IIR0 Left a1	0	57	IIR4 Right b2	0	143	Main Compressor Attack/rms Time Constant	5.75×10^{-4} (120 dB/sec)
4	IIR0 Left a2	0	58	IIR4 Right a1	0	144	Main Post- Compressor Gain	1.0
5	IIR1 Left b0	1.0	59	IIR4 Right a2	0	145–177	Subwoofer Compressor Look-Up Table Base	1.0
6	IIR1 Left b1	0	60	IIR5 Right b0	1.0	178	Sub Compressor Attack/rms Time Constant	5.75×10^{-4} (120 dB/sec)
7	IIR1 Left b2	0	61	IIR5 Right b1	0	179	Post-Compressor Gain (Sub)	1.0
8	IIR1 Left a1	0	62	IIR5 Right b2	0	180	High-Pass Filter Cutoff Frequency	
9	IIR1 Left a2	0	63	IIR5 Right a1	0	181	Main Compressor Look-Ahead Delay	0
10	IIR2 Left b0	1.0	64	IIR5 Right a2	0	182	Delay Left	0
11	IIR2 Left b1	0	65	IIR6 Right b0	1.0	183	Delay Right	0
12	IIR2 Left b2	0	66	IIR6 Right b1	0	184	Delay Sub	0
13	IIR2 Left a1	0	67	IIR6 Right b2	0	185	Stereo Spreading Coefficient	0
14	IIR2 Left a2	0	68	IIR6 Right a1	0	186	Stereo Spreading Frequency Control	0.112694
15	IIR3 Left b0	1.0	69	IIR6 Right a2	0	187	Subwoofer Reinjection to Main Left	0.0
16	IIR3 Left b1	0	70	IIR0 Xover Left b0	1.0	188	Subwoofer Reinjection to Main Right	0.0
17	IIR3 Left b2	0	71	IIR0 Xover Left b1	0	189	Subwoofer Channel Input Gain from Left In	0.5
18	IIR3 Left a1	0	72	IIR0 Xover Left b2	0	190	Subwoofer Channel Input Gain from Right In	0.5
19	IIR3 Left a2	0	73	IIR0 Xover Left a1	0	191	Main Detector Hold Time, Samples (4095 Max)	0 ¹
20	IIR4 Left b0	1.0	74	IIR0 Xover Left a2	0	192	Sub Detector Hold Time, Samples (4095 Max)	0 ¹
21	IIR4 Left b1	0	75	IIR1 Xover Left b0	1.0	193	Main Detector Decay Time	0.069611 (10000 dB/sec) ²
22	IIR4 Left b2	0	76	IIR1 Xover Left b1	0	194	Sub Detector Decay Time	0.069611 (10000 dB/sec) ²
23	IIR4 Left a1	0	77	IIR1 Xover Left b2	0	195–255	Unused	
24	IIR4 Left a2	0	78	IIR1 Xover Left a1	0			
25	IIR5 Left b0	1.0	79	IIR1 Xover Left a2	0			
26	IIR5 Left b1	0	80	IIR0 Xover Right b0	1.0			
27	IIR5 Left b2	0	81	IIR0 Xover Right b1	0			
28	IIR5 Left a1	0	82	IIR0 Xover Right b2	0			
29	IIR5 Left a2	0	83	IIR0 Xover Right a1	0			
30	IIR6 Left b0	1.0	84	IIR0 Xover Right a2	0			
31	IIR6 Left b1	0	85	IIR1 Xover Right b0	1.0			
32	IIR6 Left b2	0	86	IIR1 Xover Right b1	0			
33	IIR6 Left a1	0	87	IIR1 Xover Right b2	0			
34	IIR6 Left a2	0	88	IIR1 Xover Right a1	0			
35	IIR0 Right b0	1.0	89	IIR1 Xover Right a2	0			
36	IIR0 Right b1	0	90	IIR0 Xover Sub b0	1.0			
37	IIR0 Right b2	0	91	IIR0 Xover Sub b1	0			
38	IIR0 Right a1	0	92	IIR0 Xover Sub b2	0			
39	IIR0 Right a2	0	93	IIR0 Xover Sub a1	0			
40	IIR1 Right b0	1.0	94	IIR0 Xover Sub a2	0			
41	IIR1 Right b1	0	95	IIR1 Xover Sub b0	1.0			
42	IIR1 Right b2	0	96	IIR1 Xover Sub b1	0			
43	IIR1 Right a1	0	97	IIR1 Xover Sub b2	0			
44	IIR1 Right a2	0	98	IIR1 Xover Sub a1	0			
45	IIR2 Right b0	1.0	99	IIR1 Xover Sub a2	0			
46	IIR2 Right b1	0	100	IIR2 Xover Sub b0	1.0			
47	IIR2 Right b2	0	101	IIR2 Xover Sub b1	0			
48	IIR2 Right a1	0	102	IIR2 Xover Sub b2	0			
49	IIR2 Right a2	0	103	IIR2 Xover Sub a1	0			
50	IIR3 Right b0	1.0	104	IIR2 Xover Sub a2	0			
51	IIR3 Right b1	0	105	IIR Sub rms b0	1.0			
52	IIR3 Right b2	0	106	IIR Sub rms b1	0			
53	IIR3 Right a1	0	107	IIR Sub rms b2	0			

NOTES

¹The detector hold and decay times are integer values, while the rest of the parameters are fractional twos complement values.

²The default decay time of the hold/release circuit is set fast enough so that the decay is dominated by the time constant of the rms detector.

AD1954

that lasts for 10 ms to 20 ms. Again, this reduces the chance of any pop or click noise from occurring.

Note that this shutdown sequence assumes that the part is set to the fast volume ramp speed (Control Register 2, Bit 9). If the slow ramp speed is set, the volume may not reach zero before the part enters shutdown and a click or pop may be heard.

Safeload Mechanism

Many applications require real-time control of filter characteristics, such as bass/treble controls and parametric or graphic equalization. To prevent instability from occurring, all of the parameters of a particular biquad filter must be updated at the same time; otherwise, the filter could execute for one or two audio frames with a mixture of old and new coefficients. This mix of old and new could cause temporary instability, leading to transients that could take a long time to decay.

The method used in the AD1954 to eliminate this problem is to load a set of five registers in the SPI port with the desired parameter RAM address and data. Five registers are used because each biquad filter has five coefficients. Once these registers are loaded, the initiate safe transfer bit in Control Register 1 should be set. Once this bit is set, the processor waits for a period of time in the program sequence where the parameter RAM is not being accessed for at least five consecutive instruction cycles. When the program counter reaches this point, the parameter RAM is written with five new data values at addresses corresponding to those that were entered in the safeload registers. When the operation is complete, Bit 0 of Control Register 1 (read) is set. This bit may be polled by the external microprocessor until a 1 is read and will be reset on a read operation. The polling operation is not required; the safeload mechanism guarantees that the transfer will be complete within one audio frame.

The safeload logic automatically sends only those safeload registers that have been written to since the last safeload operation. For

example, if only two parameters are to be sent, then it is necessary to write to only two of the five safeload registers. When the request safe transfer bit is asserted, only those two registers will be sent; the other three registers are not sent and can still hold old or invalid data.

The safeload mechanism is not limited to uploading biquad coefficients; any set of five values in the parameter RAM may be updated in the same way. This allows real-time adjustment of the compressor/limiter, delay, or stereo spreading blocks.

Summary of RAM Modes

Table VII shows the sizes and available modes of the parameter RAM and the program RAM.

SPI READ/WRITE DATA FORMATS

The read/write formats of the SPI port are designed to be byte-oriented. This allows for easy programming of common microcontroller chips. To fit into a byte-oriented format, 0s are appended to the data fields to extend the data-word to the next multiple of 8 bits. For example, 22-bit words written to the SPI parameter RAM are appended with two leading zeroes to reach 24 bits (3 bytes), and 35-bit words written to the program RAM are appended with five zeros to reach 40 bits (5 bytes). These zero-extended data fields are appended to a 2-byte field consisting of a read/write bit and a 10-bit address. The SPI port knows how many data bytes to expect based on the address that is received in the first two bytes.

The total number of bytes for a single-location SPI write command can vary from 4 bytes (for a control register write) to 7 bytes (for a program RAM write). Block writes may be used to fill contiguous locations in program RAM or parameter RAM.

The read and write formats of the parameter RAM, program RAM and registers are detailed in Tables VIII to XIX.

Table VII. Read/Write Modes

Memory	Size	SPI Address Range	Read	Write	Burst Mode Available	Write Modes
Parameter RAM	256 × 22	0–255	Yes	Yes	Yes	Direct write, write after core shutdown, safeload write
Program RAM	512 × 35	512–1023	Yes	Yes	Yes	Direct write, write after core shutdown

Table VIII. Parameter RAM Read/Write Format (Single Address)

Byte 0	Byte 1	Byte 2	Byte 3	Byte 4
00000, R \overline{W} , Addr[9:8]	Addr[7:0]	00, Param[21:16]	Param[15:8]	Param[7:0]

Table IX. Parameter RAM Block Read/Write Format (Burst Moded)

Byte 0	Byte 1	Byte 2	Byte 3	Byte 4	Byte 5	Byte 8
00000, R \overline{W} , Addr[9:8]	Addr[7:0]	00, Param[21:16]	Param[15:8]	Param[7:0]	Byte 6	Byte 9
					Byte 7	Byte 10

←——— ADDR ———→ ADDR + 1 ADDR + 2

Table X. Program RAM Read/Write Format (Single Address)

Byte 0	Byte 1	Byte 2	Byte 3	Byte 4	Byte 5	Byte 6
00000, R \overline{W} , Addr[9:8]	Addr[7:0]	00000, Prog[34:32]	Prog[31:24]	Prog[23:16]	Prog[15:8]	Prog[7:0]

Table XI. Program RAM Read/Write Format (Burst Address)

Byte 0	Byte 1	Byte 2	Byte 3	Byte 4	Byte 5	Byte 6	Byte 7	Byte 8	Byte 9	Byte 10	Byte 11	Byte 12	Byte 13	Byte 14	Byte 15	Byte 16
00000, R \overline{W} , Addr[9:8]	Addr[7:0]	00000, Prog[34:32]	Prog[31:24]	Prog[23:16]	Prog[15:8]	Prog[7:0]										
← <i>ADDR</i> →												<i>ADDR + 1</i>	<i>ADDR + 2</i>			

Table XII. SPI Control Register 1 Write Format

Byte 0	Byte 1	Byte 2	Byte 3
00000, R \overline{W} , Addr[9:8]	Addr[7:0]	0000, Bit[11:8]	Bit[7:0]

Table XIII. SPI Control Register 1 Read Format

Byte 0	Byte 1	Byte 2
00000, R \overline{W} , Addr[9:8]	Addr[7:0]	000000, Bit[1:0]

Table XIV. SPI Control Register 2 Write Format

Byte 0	Byte 1	Byte 2	Byte 3
00000, R \overline{W} , Addr[9:8]	Addr[7:0]	000000, Bit[9:8]	Bit[7:0]

Table XV. SPI Volume Register Write Format

Byte 0	Byte 1	Byte 2	Byte 3	Byte 4
000000, Addr[9:8]	Addr[7:0]	00, Volume[21:16]	Volume[15:8]	Volume[7:0]

Table XVI. Data Capture Register Write Format

Byte 0	Byte 1	Byte 2	Byte 3
00000, R \overline{W} , Addr[9:8]	Addr[7:0]	00000, ProgCount[8:6]1	ProgCount[5:0], RegSel[1:0] ^{1,2}

NOTES

¹ProgCount[8:0] = value of program counter where trap occurs (see Table XX).²RegSel[1:0] selects one of four registers (see Data Capture Register section).

Table XVII. Data Capture Serial Out Register (Address and Register Select) Write Format

Byte 0	Byte 1	Byte 2	Byte 3
00000, R \overline{W} , Addr[9:8]	Addr[7:0]	00000, ProgCount[8:6]1	ProgCount[5:0], RegSel[1:0] ^{1,2}

NOTES

¹ProgCount[8:0] = value of program counter where trap occurs (see Table XX).²RegSel[1:0] selects one of four registers (see Data Capture Register section).

Table XVIII. Data Capture Read Format

Byte 0	Byte 1	Byte 2	Byte 3	Byte 4	Byte 5
00000, R \overline{W} , Addr[9:8]	Addr[7:0]	00000000	Data[23:16]	Data[15:8]	Data[7:0]

Table XIX. Safeload Register Write Format

Byte 0	Byte 1	Byte 2	Byte 3	Byte 4	Byte 5
00000, R \overline{W} , Addr[9:8]	Addr[7:0]	ParamAddr[7:0]	00, Param[21:16]	Param[15:8]	Param[7:0]

AD1954

INITIALIZATION

Power-Up Sequence

The AD1954 has a built-in power-up sequence that initializes the contents of the internal RAMs. During this time, the contents of the internal program boot ROM are copied to the internal program RAM memory, and likewise, the SPI parameter RAM is filled with values from its associated boot ROM. The data memories are also cleared during this time.

The boot sequence lasts for 1024 MCLK cycles and starts on the rising edge of the RESETB pin. Since the boot sequence requires a stable master clock, the user should avoid writing to or reading from the SPI registers during this period of time. Note that the default power-on state of the internal clock mode circuitry is $512 \times f_s$, or about 24 MHz for normal audio sample rates. This mode bypasses all the internal clock doublers and allows the external master clock to directly operate the DSP core. If the external master clock is $256 \times f_s$, then the boot sequence will operate at this reduced clock rate and will take slightly longer to complete. After the boot sequence has finished, the clock modes may be set via the SPI port. For example, if the external master clock frequency is $256 \times f_s$ clock, the boot sequence would take $1024 \times 256 \times f_s$ clock cycles to complete, after which an SPI write could occur to put the AD1954 in $256 \times f_s$ mode.

The default state of the MCLK input selector is MCLK0. Since this input selector is controlled using the SPI port, and the SPI port cannot be written to until the boot sequence is complete, there must be a stable master clock signal present on the MCLK0 pin at startup.

Setting the Clock Mode

The AD1954 contains a clock doubler circuit that is used to generate an internal $512 \times f_s$ clock when the external clock is $256 \times f_s$. The clock mode is set by writing to Bit 2 of Control Register 2.

When the clock mode is changed, it is possible that a glitch will occur on the internal MCLK signal. This may cause the processor to inadvertently write an incorrect value into the data RAM, which could cause an audio pop or click sound. To prevent this the following procedure is recommended:

1. Assert the soft power-down bit (Bit 6 in Control Register 1) to stop the internal MCLK.
2. Write the desired clock mode into Bit 2 of Control Register 2.
3. Wait at least 1 ms while the clock doublers settle.
4. De-assert the soft power-down bit.

An alternative procedure is to initiate a soft shutdown of the processor core by writing a 1 to the halt program bit in Control Register 1. This initiates a volume ramp-down sequence followed by a shutdown of the DSP core. Once the core is shut down (which can be verified by reading Bit 1 from Control Register 1 or by waiting at least 20 ms), the new clock mode can be programmed by writing to Bit 2 of Control Register 2. The DSP core can then be restarted by clearing the halt program bit in Control Register 1.

Setting the Data and MCLK Input Selectors

The AD1954 contains input selectors for both serial data inputs and the MCLK input. This allows the AD1954 to select a variety of input and clock sources with no external hardware required. These input selectors are controlled by writing to SPI Control Register 2.

When the data source or MCLK source is changed by writing to the SPI port, it is possible that a pop or click will occur in the audio. To prevent this noise, the core should be shut down by writing a 1 to the halt program bit in Control Register 1. This initiates a volume ramp-down sequence followed by a shutdown of the DSP core. Once the core is shut down (which can be verified by reading Bit 1 from Control Register 1 or by waiting at least 20 ms after the halt program command is issued), the new data or MCLK source can be programmed by writing to Control Register 2. The DSP core can then be restarted by clearing the halt program bit in Control Register 1.

DATA CAPTURE REGISTERS

The AD1954 incorporates a feature called data capture. Using this feature, any node in the signal processing flow may be sent to either an SPI readable register or a dedicated serial output pin. This allows the basic functionality of the AD1954 to be extended to a larger number of channels. Alternatively, it can be used to monitor and display information about signal levels or compressor/limiter activity.

The AD1954 contains four independent data capture registers. Two of these registers transfer their data to the data capture serial output (DCSOUT) pin. The serial data format of this pin is the same as the serial data format used for the main digital inputs, and the LRCLK and BCLK signals can therefore be used as frame sync and bit clock signals. This pin is primarily intended to feed signals to an external DAC or DSP chip to extend the number of channels that the internal DSP can access. The other two registers may be read back over the SPI port and can be used for a variety of purposes. One example might be to access the dB output of the internal rms detector to run a front-panel signal level display. A sample system is shown in Figure 19. For each of the four data capture registers, a capture count and a register select must be set. The capture count is a number between 0 and 511 that corresponds to the program step number where the capture will occur. The register select field programs one of four registers in the DSP core that will be transferred to the data capture register when the program counter equals the capture count. The register select field is decoded as follows:

- 00: Multiplier Output (Mult_Out)
- 01: Output of dB Conversion Block (DB_OUT)
- 10: Multiplier Data Input (MDI)
- 11: Multiplier Coefficient Input (MCI)

The capture count and register select bits are set by writing to one of the four data capture registers at the following SPI addresses:

- 261: SPI Data Capture Setup Register 1
- 262: SPI Data Capture Setup Register 2
- 263: Data Capture Serial Out Setup Register 1
- 264: Data Capture Serial Out Setup Register 2

The format of the captured data varies according to the register select fields. Data captured from the `mult_out` setting is in 1.23 twos complement format so that a full-scale input signal will produce a full-scale digital output (assuming no processing). If the parameters are set such that the input-to-output gain is more than 0 dB, then the digital output will be clipped.

Data captured from the `DB_OUT` setting is in 5.19 format, where the actual rms dB level is equal to $-87 + (3 \times DB_OUT)$. In this equation, `DB_OUT` is the value that is captured. It follows that in this data format, the actual output readings will range from -87 dB to +9 dB. The AD1954 uses the convention that 0 dB is the rms value of the full-scale digital signal.

Data captured using the `MDI` setting is in 3.21 format. A 0 dB digital input will produce a -12 dB digital output, assuming the AD1954 is set for no processing.

Data captured using the `MCI` setting is in 2.20 format. This data is generally a signal gain or filter coefficient, and therefore it does not make sense to talk about the input-to-output gain. A coefficient of 01000000000000000000 corresponds to a gain of 1.0.

The data that must be written to set up the data capture is a concatenation of the 9-bit program count index with the 2-bit register select field. Refer to Table XX to find the capture count and register select numbers that correspond to the desired point to be monitored in the default signal processing flow.

The SPI capture registers can be accessed by reading from SPI Locations 261 (for SPI Capture Register 1) or 262 (for SPI Capture Register 2). The other two data capture registers (data capture serial out) automatically transfer their data to the data capture serial out (DCSOUT) pin. DCSOUT Capture Register 1 is present in the left data slot (as defined by the serial input format), and DCSOUT Capture Register 2 is present in the right data slot. The format for writing to the SPI data capture setup registers is given in the SPI section of this data sheet.

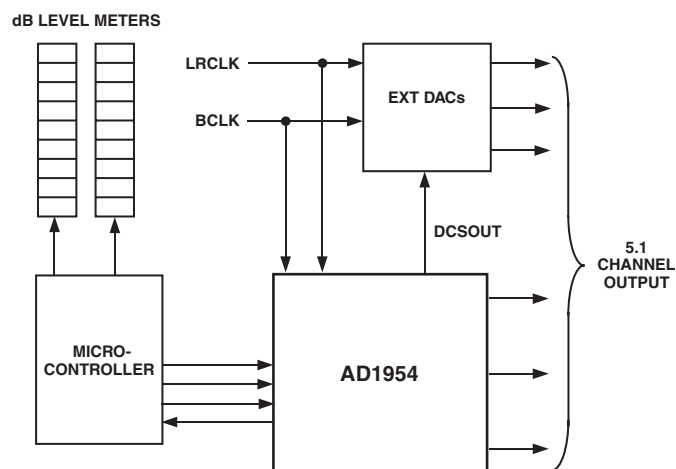

Figure 19. Typical Application of Data Capture Feature

AD1954

Table XX. Data Capture Trap Indexes and Register Select—Default Program

Signal Description	Program Count Index (9 Bits)	Register Select (2 Bits)	Numeric Format
HPF Out Left	15	Mult_Out	1.23, Clipped
HPF Out Right	259	Mult_Out	1.23, Clipped
De-emphasis Out Left	19	Mult_Out	1.23, Clipped
De-emphasis Out Right	263	Mult_Out	1.23, Clipped
Left Biquad 0 Output	34	Mult_Out	1.23, Clipped
Left Biquad 1 Output	43	Mult_Out	1.23, Clipped
Left Biquad 2 Output	52	Mult_Out	1.23, Clipped
Left Biquad 3 Output	61	Mult_Out	1.23, Clipped
Left Biquad 4 Output	70	Mult_Out	1.23, Clipped
Left Biquad 5 Output	79	Mult_Out	1.23, Clipped
Left Biquad 6 Output	88	Mult_Out	1.23, Clipped
Right Biquad 0 Output	284	Mult_Out	1.23, Clipped
Right Biquad 1 Output	293	Mult_Out	1.23, Clipped
Right Biquad 2 Output	302	Mult_Out	1.23, Clipped
Right Biquad 3 Output	311	Mult_Out	1.23, Clipped
Right Biquad 4 Output	320	Mult_Out	1.23, Clipped
Right Biquad 5 Output	329	Mult_Out	1.23, Clipped
Right Biquad 6 Output	338	Mult_Out	1.23, Clipped
Volume Out Left	114	Mult_Out	1.23, Clipped
Volume Out Right	111	Mult_Out	1.23, Clipped
Volume Out Sub	459	Mult_Out	1.23, Clipped
Phat Stereo Out Left	115	Mult_Out	1.23, Clipped
Phat Stereo Out Right	112	Mult_Out	1.23, Clipped
Delay Output Left	190	Mult_Out	1.23, Clipped
Delay Output Right	361	Mult_Out	1.23, Clipped
Main Compressor rms Out (dB)	154	DB_Out	24-Bit Positive Binary, Bit 19 Corresponds to a 3 dB Change
Main Compressor Gain Reduction (Linear)	165	MCI	2.22, 2 LSBs = 0
Look-Ahead Delay Output Left	165	MDI	3.21, 2 LSBs Truncated
Look-Ahead Delay Output Right	178	MDI	3.21, 2 LSBs Truncated
Main Compressor Out Left	175	Mult_Out	1.23, Clipped
Main Compressor Out Right	188	Mult_Out	1.23, Clipped
Interpolator Input Left (Includes Sub Reinject)	191	Mult_Out	1.23, Clipped
Interpolator Input Right (Includes Sub Reinject)	362	Mult_Out	1.23, Clipped
Subchannel Filter Input	430	Mult_Out	1.23, Clipped
Sub Xover Biquad 0 Output	438	Mult_Out	1.23, Clipped
Sub Xover Biquad 1 Output	447	Mult_Out	1.23, Clipped
Sub Xover Biquad 2 Output	456	Mult_Out	1.23, Clipped
Left Xover Biquad 0 Output	99	Mult_Out	1.23, Clipped
Left Xover Biquad 1 Output	108	Mult_Out	1.23, Clipped
Right Xover Biquad 0 Output	349	Mult_Out	1.23, Clipped
Right Xover Biquad 1 Output	358	Mult_Out	1.23, Clipped
Sub Delay Output	511	Mult_Out	1.23, Clipped
Sub rms Biquad Output	467	Mult_Out	1.23, Clipped
Sub rms Output (dB)	489	DB_Out	24-Bit Positive Binary, Bit 19 Corresponds to a 3 dB Change
Sub Compressor Gain (Linear)	495	MCI	2.22, 2 LSBs = 0
Subchannel Output	511	Mult_Out	1.23, Clipped

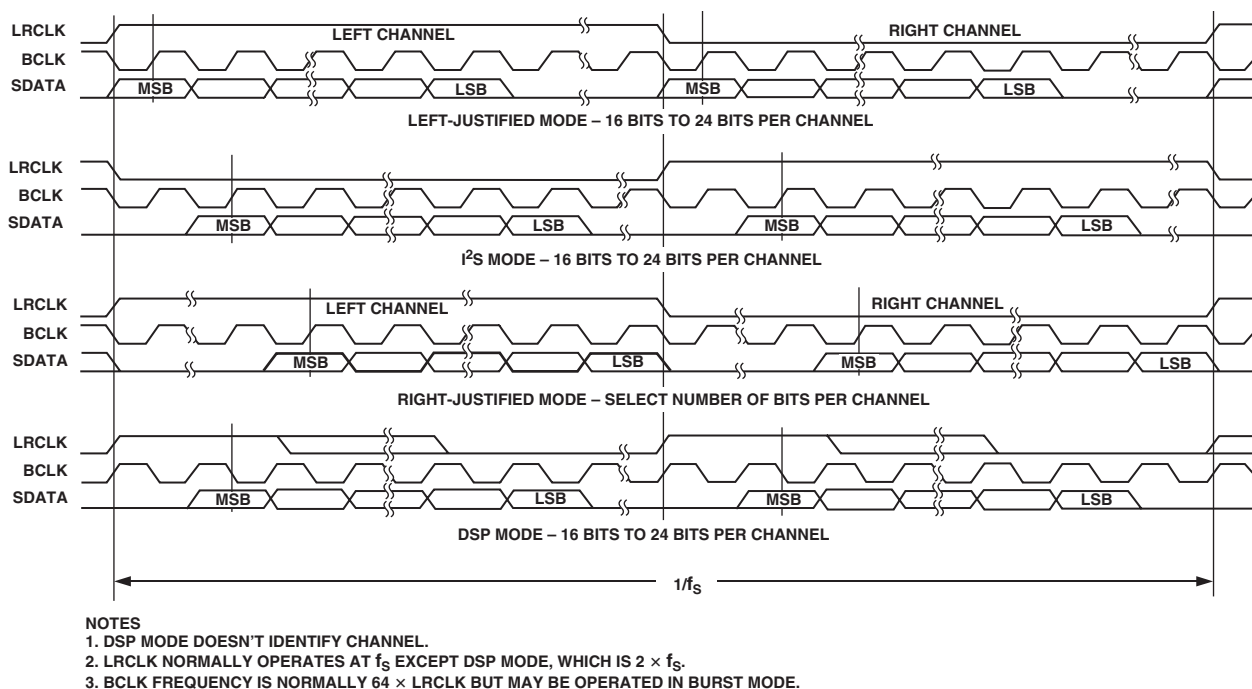

Figure 20. Serial Input Modes

SERIAL DATA INPUT PORT

The AD1954's flexible serial data input port accepts data in two's complement, MSB first format. The left channel data field always precedes the right channel data field. The serial mode is set by using mode select bits in the SPI control register. In all modes except for the right-justified mode, the serial port will accept an arbitrary number of bits up to a limit of 24 (extra bits will not cause an error, but they will be truncated internally). In the right-justified mode, SPI control register bits are used to set the word length to 16 bits, 20 bits, or 24 bits. The default on power-up is 24-bit mode. Proper operation of the right-justified mode requires exactly 64 BCLKs per audio frame.

Serial Data Input Modes

Figure 20 shows the serial input modes. For the left-justified mode, LRCLK is high for the left channel and low for the right channel. Data is sampled on the rising edge of BCLK. The MSB is left-justified to an LRCLK transition, with no MSB delay. The left-justified mode can accept any word length up to 24 bits.

In I²S mode, LRCLK is low for the left channel and high for the right channel. Data is valid on the rising edge of BCLK. The MSB is left-justified to an LRCLK transition but with a single BCLK period delay. The I²S mode can be used to accept any number of bits up to 24.

In right-justified mode, LRCLK is high for the left channel and low for the right channel. Data is sampled on the rising edge of BCLK. The start of data is delayed from the LRCLK edge by 16 BCLK, 12 BCLK, or 8 BCLK intervals, depending on the selected word length. The default word length is 24 bits; other word lengths are set by writing to Bits 1 and 0 of Control Register 1. In right-justified mode, it is assumed that there are 64 BCLKs per frame.

For the DSP serial port mode, LRCLK must pulse high for at least one bit clock period before the MSB of the left channel is valid, and LRCLK must pulse high again for at least one bit

clock period before the MSB of the right channel is valid. Data is sampled on the falling edge of BCLK. The DSP serial port mode can be used with any word length up to 24 bits. In this mode, it is the responsibility of the DSP to ensure that the left data is transmitted with the first LRCLK pulse and that synchronism is maintained from that point forward.

DIGITAL CONTROL PINS

Mute

The AD1954 offers two methods of muting the analog output. By asserting the mute signal high, the left, right, and subchannels are muted. As an alternative, the user can assert the mute bit in the serial control register high. The AD1954 has been designed to minimize pops and clicks when muting and unmuting the device by automatically ramping the gain up or down. When the device is unmuted, the volume returns to the value set in the volume register.

De-emphasis

The AD1954 has a built-in de-emphasis filter that can be used to decode CDs that have been encoded with the standard redbook 50 μ s/15 μ s emphasis response curve. This feature may be activated by the pin or by an SPI write to the control register. When activating with the pin, only the 44.1 kHz sample rate curve is available. When using the SPI port, curves for 44.1 kHz, 32 kHz, and 48 kHz are supported.

AD1954

ANALOG OUTPUTSECTION

Figure 21 shows the block diagram of the analog output section. A series of current sources are controlled by a digital Σ - Δ modulator. Depending on the digital code from the modulator, each current source is connected to the summing junction of either a positive I-to-V converter or a negative I-to-V converter. Two extra current sources that push instead of pull are added to set the midscale common-mode voltage.

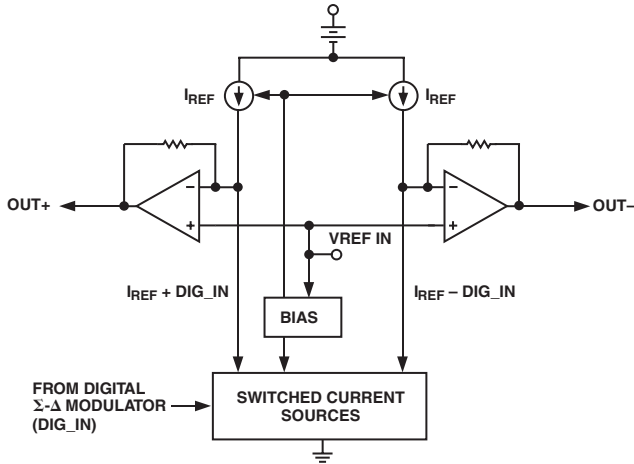

Figure 21. Internal DAC Analog Architecture

All current sources are derived from the VREF input pin. The gain of the AD1954 is directly proportional to the magnitude of the current sources, and therefore the gain of the AD1954 is proportional to the voltage on the VREF pin. With VREF set to 2.5 V, the gain of the AD1954 is set to provide signal swings of 2 V rms differential (1 V rms from each pin). This is the recommended operating condition.

When the AD1954 is used to drive an audio power amplifier and the compression feature is being used, the VREF voltage should then be derived by dividing down the supply of the amplifier. This sets a fixed relationship between the digital signal level (which is the only information available to the digital compressor) and the full-scale output of the amplifier (just prior to the onset of clipping). For example, if the amplifier power supply drops by 10%, then the VREF input to the amplifier will also drop by 10%, which will reduce the analog output signal swing by 10%. The compressor will therefore be effective in preventing clipping, regardless of any variation in amplifier supply voltage.

Since the VREF input effectively multiplies the signal, care must be taken to ensure that no ac signals appear on this pin. This can be accomplished by using a large decoupling capacitor in the VREF external resistive divider circuit. If the VREF signal is derived by dividing the 5 V analog supply, then the time constant of the divider must effectively filter any noise on the supply. If the VREF signal is derived from an unregulated power amplifier supply, then the time constant must be longer, since the ripple on the amplifier supply voltage will presumably be greater than in the case of the 5 V supply.

The AD1954 should be used with an external third order filter on each output channel. The circuit shown in Figures 22, 23, and 24 combine a third order filter and a single-ended-to-differential converter in the same circuit. The values used in the main channel (Figure 22) are for a 100 kHz Bessel filter, and those used in the subwoofer channel (Figure 23) result in a 10 kHz Bessel filter.

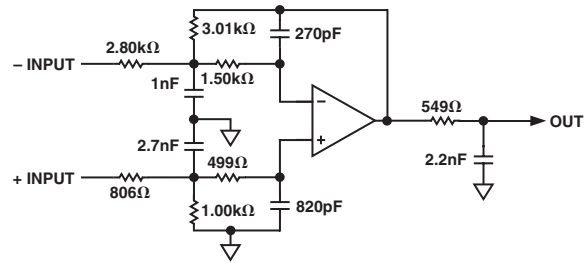

Figure 22. Recommended External Analog Filter for Main Channel

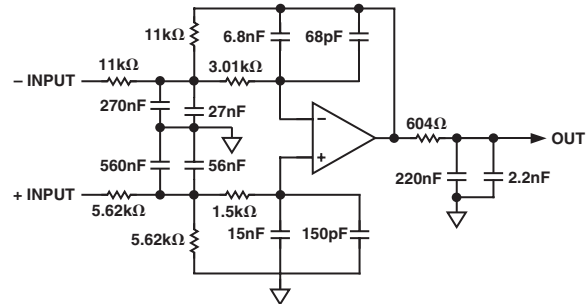

Figure 23. Recommended External Analog Filter for Subchannel

The lower frequency filter is used on the subwoofer output because there is no digital interpolation filter used in the subwoofer signal path. When calculating the resistor values for the filter, it is important to take into account the output resistance of the AD1954, which is nominally 60 Ω. For best distortion performance, 1% resistors should be used. The reason for this is that the single-ended performance of the AD1954 is about 80 dB. The degree to which the single-ended distortion cancels in the final output is determined by the common-mode rejection of the external analog filter, which in turn depends on the tolerance of the components used in the filter.

The sub output of the AD1954 has a lower drive strength than the left and right output pins (± 0.25 mA peak versus ± 0.5 mA peak for the left and right outputs). For this reason, it is best to use higher resistor values in the external sub filter.

Figure 24 shows a recommended filter design for the subwoofer pins used as a full bandwidth channel in a custom designed program. This design is also a 100 kHz Bessel filter.

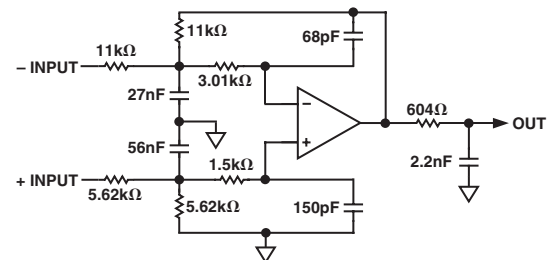

Figure 24. Recommended External Analog Filter for Full Bandwidth Signals on the Subchannel Output

For best performance, a large (>10 μ F) capacitor should be connected between the FILTCAP pin and analog ground. This pin is connected to an internal node in the bias generator, and by adding an external capacitance to this pin, the thermal noise of the left/right channels is minimized. The sub channel is not affected by this connection.

GRAPHICAL CUSTOM PROGRAMMING TOOLS

Custom programming tools are available for the AD1954 from ADI. These graphical tools allow the user to modify the default signal processing flow by individually placing each block (e.g., biquad filter, Phat Stereo, dynamics processor) and connecting them in any desired fashion. The program then creates a file that is loaded into the AD1954's program RAM. All of the contents of the parameter RAM can also be set using these tools. For more information on these programming tools, contact SigmaDSP@analog.com.

AD1954

APPENDIX

Cookbook Formulae for Audio EQ Biquad Coefficients (Adapted from Robert Bristow-Johnson's Internet Posting)

For designing a parametric EQ, follow the steps below.

1. Given:

Frequency
Q
dB_Gain
Sample_Rate

2. Compute intermediate variables:

$A = 10^{(\text{dB_Gain}/40)}$
 $\omega = 2 \times \pi \times \text{Frequency}/\text{Sample_Rate}$
 $\text{sn} = \sin(\omega)$
 $\text{cs} = \cos(\omega)$
 $\alpha = \text{sn}/(2 \times Q)$

3. Compute coefficients:

$b_0 = (1 + A \times \alpha)/(1 + (\alpha/A))$
 $b_1 = -2 \times \text{cs}/(1 + (\alpha/A))$
 $b_2 = (1 - (\alpha \times A))/(1 + (\alpha/A))$
 $a_1 = 2 \times \text{cs}/(1 + (\alpha/A)) = -b_1$
 $a_2 = -(1 - (\alpha/A))/(1 + (\alpha/A))$

4. The transfer function implemented by the AD1954 is given by:

$$H(Z) = \frac{(b_0 + b_1 \times Z^{-1} + b_2 \times Z^{-2})}{(1 - a_1 \times Z^{-1} - a_2 \times Z^{-2})}$$

Note the inversion in sign of a_1 and a_2 relative to the more standard form. This form is used in this document because the AD1954 implements the difference equation using the formula below.

$$Y(n) = a_1 \times y(n-1) + a_2 \times y(n-2) + b_0 \times x(n) + b_1 \times x(n-1) + b_2 \times x(n-2)$$

AD1954

Revision History

Location	Page
8/03—Data Sheet changed from REV. 0 to REV. A.	
Changes to SPECIFICATIONS	3
Changes to ABSOLUTE MAXIMUM RATINGS	6
Changes to ORDERING GUIDE	6
Change to TPCs 1 and 2	8
Change to Main Compressor/Limiter section	15
Change to Interpolation Filters section	18
Replaced Control Register 1 section	20
Changes to Control Register 2 section	21
Changes to Parameter RAM Contents section	22
Change to Table VI	23
Change to Table IX	24
Change to Table XI	25
Change to DATA CAPTURE REGISTERS section	26
Change to Table XX	28
Change to ANALOG OUTPUT SECTION section	30
Reversed Figures 22 and 23	30
Added Figure 24	30
Updated OUTLINE DIMENSIONS	33

This datasheet has been downloaded from:

www.DatasheetCatalog.com

Datasheets for electronic components.



LittleDiode supplies new, hard to find or obsolete electronic components and semiconductors all over the world.

With over two million different components listed you are sure to find the part you need.

Feel free to visit us today at our online store:

LittleDiode.com

Looking forward to providing you with the best possible service.