

FEATURES

- Continuous Status Checks of Five Bulbs
- Lamp Status Check in "ON" and "OFF" States
- Status Checks of Two In-Line Fuses
- Very Low Voltage Drop at Sensor Shunt Resistor
(Comparator Threshold 1.75 mV at 22°C)
- Temperature and Supply Voltage Compensated
- Powered Directly from Car Battery: Protection
Included for Transient, Reverse Supply, Load Dump
- Operating Temperature Range: -40°C to +125°C
- 15 V CMOS Compatible Digital Output Signals
- Voltage Limited Power Supply Output for 15 V CMOS
Logic ICs

GENERAL DESCRIPTION

The AD22001 is a monolithic, five-channel comparator circuit for monitoring the functionality of lamps in automotive applications.

The IC tests the series circuit leading to the lamp to determine if the circuit is intact and a functional lamp is in the socket. The AD22001 continuously checks the functionality of up to five bulbs in either their "on" or "off" state, and also tests for the presence of an in-line fuse in two of the series circuits.

Digital outputs indicate the status of each channel. Additionally, the AD22001 provides a voltage limited power supply output to supply 15 V CMOS circuits that may interface to the AD22001.

FUNCTIONAL BLOCK DIAGRAM

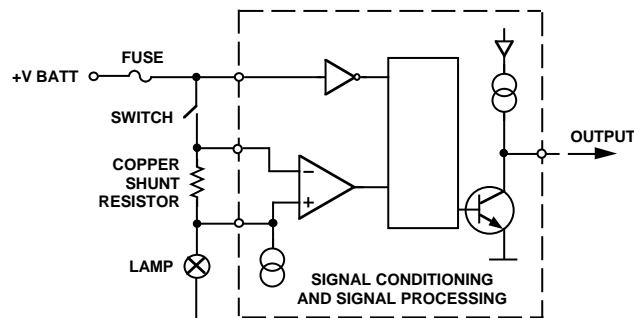
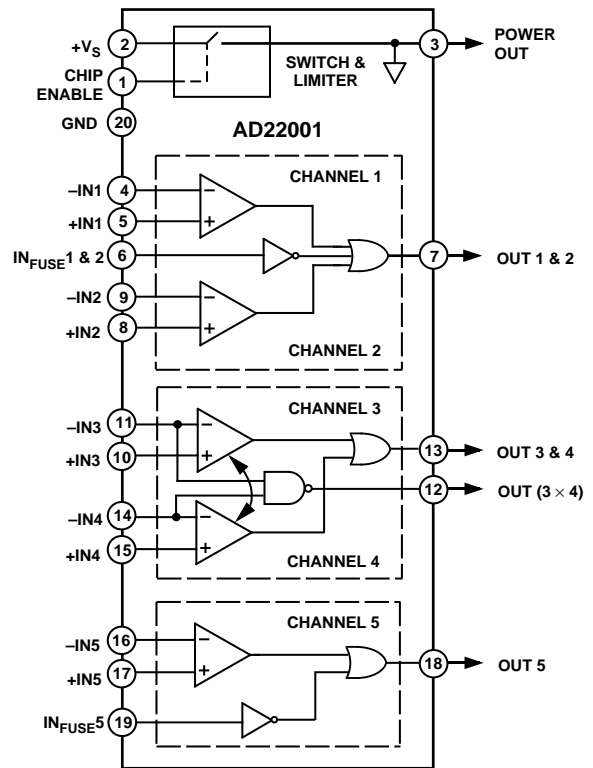

Figure 1. Typical Application Circuit for a Single Channel Lamp Monitor

REV. A

Information furnished by Analog Devices is believed to be accurate and reliable. However, no responsibility is assumed by Analog Devices for its use, nor for any infringements of patents or other rights of third parties which may result from its use. No license is granted by implication or otherwise under any patent or patent rights of Analog Devices.

AD22001–SPECIFICATIONS ($T_A = +22^\circ\text{C}$, $V_S = +13.5\text{ V}$ unless otherwise noted)

Parameter		Test Conditions	Min	Typ	Max	Units
DIFFERENTIAL INPUTS (Voltage Drop from Shunt Resistor: Pins 4 & 5, 8 & 9, 10 & 11, 14 & 15, 16 & 17)						
V_{INDIFF}	Comparator Threshold Voltage ¹	$9\text{ V} \leq V_S \leq 16\text{ V}$	1.5	1.75	2.0	mV
V_{INCM}	Common-Mode Threshold Voltage ¹		5			V
	Power Supply Sensitivity of V_{INDIFF} ²			50		%
	Temperature Compensation of V_{INDIFF} ³			3770		ppm/°C
I_{INB}	Input Bias Current			10		μA
I_{INC}	Constant Current Source ⁴		30	60		μA
SINGLE-ENDED INPUTS (Fuse Monitoring: Pins 6, 19)						
V_{INF}	Fuse Input Threshold Voltage ⁵				4	V
CHIP ENABLE CONTROL INPUT (Pin 1)						
V_{INCE}	Chip Enable, Input High		9			V
V_{INCD}	Chip Disable (Stop Operation) ⁶				6	V
OUTPUTS (Pins 7, 12, 13, 18)						
V_{OUTL}	Output Voltage, Low Indicates No Fault in Lamp Circuit	Load = 500 μA			0.6	V
V_{OUTH}	Output Voltage, High Indicates Fault in Lamp Circuit	$9\text{ V} \leq V_S \leq V_{\text{SSDH}}$ Load = 50 μA	$V_{\text{OUTPS}} - 2.5$		V_{OUTPS}	V
POWER SUPPLY (Pin 2: + V_S , Pin 20: GND)						
V_S	Supply Voltage		9		30	V
I_S	Quiescent Supply Current V_{OUTH} : No Load	Pin 1 High Pin 1 Low	1	3 100	5	mA μA
POWER SUPPLY OUTPUT (Pin 3)						
V_{OUTPS}	Power Supply Output Voltage	$10\text{ V} < V_S < 14.5\text{ V}$ $I_{\text{OUTPS}} \leq 1\text{ mA}$	$V_S - 0.5$	$V_S - 0.3$	V_S	V
I_{OUTPS}	Max Output Voltage Power Supply Output Current ⁷		2	16	18	V mA
OPERATING SHUTDOWN (Safety Features)						
V_{SSDH}	Operation Shutdown at High Power Supply Voltages ⁸		30	33	36	V
V_{SSDL}	Operation Shutdown at Low Power Supply Voltage ⁹		7		9	V
TEMPERATURE RANGE						
T_A	Operating Temperature Range		-40		+125	°C
PACKAGE						
	Plastic DIP (N-20)			AD22001N		

NOTES

¹In the presence of a common-mode voltage greater than 5 V, if the shunt voltage applied to the comparator does not exceed the threshold (i.e., the bulb is switched on but does not draw current), then the device will indicate a failure.

²At $V_S = 13.5\text{ V}$, the differential input threshold voltage is typically 1.75 mV. With an increase of V_S , the threshold voltage, V_{INDIFF} , will change as well. Power supply sensitivity of 50% means that when the power supply voltage V_S increases by 10%, the threshold voltage V_{INDIFF} will be increased by half of this percentage value: 5%.

³This is the temperature coefficient to compensate for any temperature influence on the external copper PCB track shunt resistors. 3770 ppm/°C is equal to 6.6 μV/°C.

⁴This current source is used to test the lamp when it is switched off (cold lamp test).

⁵If the voltage at the input from the fuse (Pin 6 or 19) does not exceed the threshold voltage, then the output will indicate a failure.

⁶When the Chip Enable is open-circuited, the chip is disabled.

⁷Shorting V_{OUTPS} to ground will cause the device to stop operating for that period. However, the device will not suffer any damage.

⁸At this voltage, or above, the internal power supply and the power output V_{OUTPS} will be shut off.

⁹Below the minimum voltage, the circuit will shut down. Above the maximum, the circuit will be on if enabled.

All min and max specifications are guaranteed, although only those marked in **boldface** are tested on all production units at final test. Specifications subject to change without notice.

ABSOLUTE MAXIMUM RATINGS*

Forward Supply Voltage	+36 V
Reversed Supply Voltage	-34 V
Forward Transient (40 ms)	+60 V
Reverse Transient (40 ms)	-40 V
Voltage on Any Input Pin Relative to GND	-34 V to +36 V
Power Dissipation ($V_S = 13.5\text{ V}$)	300 mW
Operating Temperature (Ambient)	-40°C to +125°C
Storage Temperature	-65°C to +150°C

*Stresses above those listed under "Absolute Maximum Ratings" may cause permanent damage to the device. This is a stress rating only, the functional operation of the device at these or any other conditions above those indicated in the operational sections of this specification is not implied. Exposure to absolute maximum rating conditions for extended periods may affect device reliability.

ORDERING INFORMATION

Model	Temperature Range	Package Option*
AD22001N	-40°C to +125°C	N-20

*N = Plastic DIP Package.

CONNECTION DIAGRAM

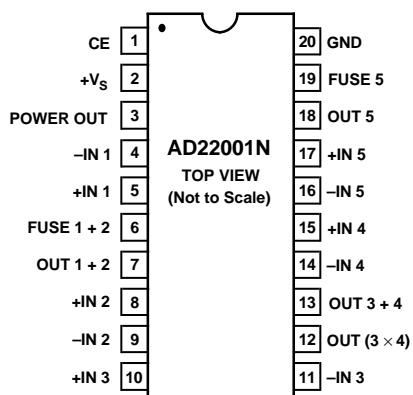

PRODUCT DESCRIPTION

The AD22001's five comparators each monitor the voltage across a current sensing shunt resistor which is part of a lamp circuit. Each comparator has a small threshold voltage, nominally 1.75 mV. The output of the comparator will change state as the voltage developed across the shunt (by the lamp current) crosses the threshold level. Because the threshold voltage is very small, copper tracks on the PC board can be used as shunt resistors with low power dissipation.

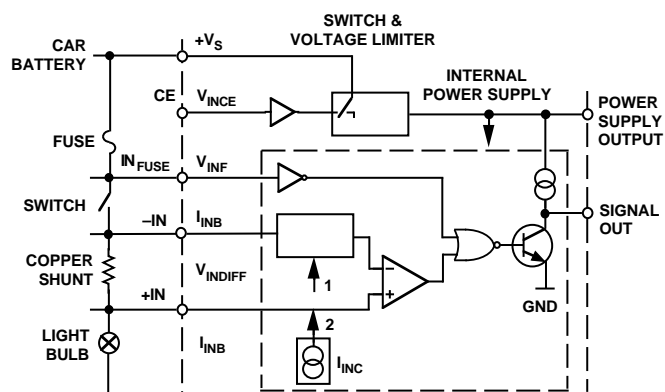

NOTES

- TEMPERATURE COMPENSATION FOR COPPER SHUNT RESISTOR AND SUPPLY VOLTAGE COMPENSATION.
- CURRENT SOURCE FOR COLD BULB CHECKING (AVAILABLE IN CHANNELS 1, 2, 3 AND 4).

Figure 2. Typical Block Diagram of One Channel and Power Supply Control

The AD22001 has internal linear signal processing that compensates the comparator threshold voltage as the resistance of the copper shunt resistor changes with varying temperature. The comparator thresholds are also adjusted to compensate for changes in lamp current due to power supply variations.

The AD22001 was designed for a common automotive lamp monitoring application. The connection diagram (Figure 3) and the application suggestion (Figure 4) show the different combinations of functions that are performed for each channel.

FUNCTIONAL DESCRIPTION

The AD22001 consists of fine sensitive comparators with built-in offset plus biasing and support for comprehensive lamp circuit monitoring. The comparators are arrayed as a single and two groups of two (as shown in Figure 3) arranged to meet a variety of requirements. Two or more AD22001s can be combined. The comparators are basically similar with additional features according to their place in the array.

Hot Lamp Test

Each comparator has a differential input with built-in threshold of 1.75 mV, under nominal operating conditions. The comparators are intended to monitor the voltage developed across a low resistance shunt by a lamp current. The comparators are active whenever they are connected to the battery circuit. They indicate normal or okay (the series circuit to the lamp is intact) when the threshold voltage of 1.75 mV is exceeded. This occurs when the +input is driven negative with respect to the -input by a voltage greater than the threshold. They also indicate normal if they are not activated by common-mode battery voltage, whether the threshold voltage is exceeded or not. They indicate a fault if the common-mode is applied but the threshold is not exceeded.

AD22001

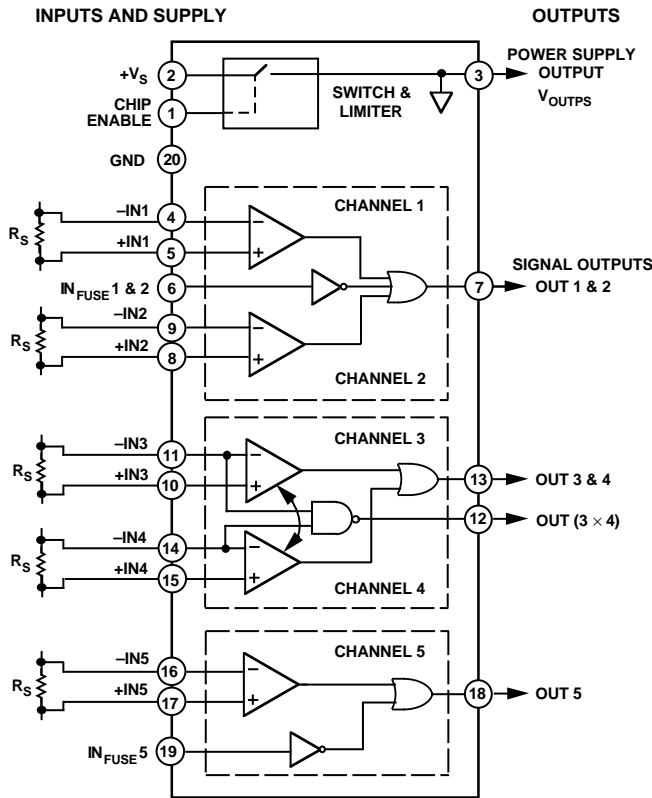

Figure 3. AD22001 Connection Diagram

Thus, in the absence of voltage applied to light the lamp, the lamp resistance holds the common-mode voltage low, and no fault is indicated. When the lamp circuit is powered, voltage on the comparator inputs activates the comparator which indicates a fault if the lamp current does not cause the shunt voltage to exceed the threshold.

Cold Lamp Test

In addition to the standard hot lamp test, four of the comparators have a cold lamp test current of about 60 μA applied. If the lamp circuit is not switched on but the lamp circuit is incomplete (failed lamp or connection), the small test current will raise the common-mode voltage of the comparator at its input and cause it to indicate a fault. Individual comparator inputs draw about 10 μA each.

Description of Channel 5

The single comparator in Channel 5 is intended for brake-light testing. Comparator 5 does not have the cold test feature, since this lamp is normally tested in conjunction with the brake-light switch. The comparator is combined with a fuse test circuit which checks for battery voltage at its input. This input normally connects between the fuse and brake-light switch.

The outputs of the hot lamp test and the fuse test are combined at OUT 5 which indicates zero or low as the normal or okay state and one or high if either test fails. The output will indicate a fault if battery voltage is lost from the fuse test line, or if the lamp circuit is powered, but the circuit fails to draw current.

Description of Channels 3 and 4

Comparators 3 and 4 are linked to test pairs of lamp circuits. In addition to the hot lamp test, Channels 3 and 4 each have a cold lamp test current. A fault for either test at input 3 or 4 will

cause their common output, OUT 3 & 4, to indicate failure (registered as a one or high).

These comparators are intended for lamp circuits which are switched simultaneously, but are fused independently. A special linkage between the comparators causes them to indicate a fault if common-mode voltage is applied to only one of the pair. This functions as a test of both fuses.

One additional output is provided which tests when both lamps are switched on (whether the lamp circuit draws current or not). This circuit signals a zero or low level at OUT (3 \times 4) whenever both lamp circuits are powered (implying fuses are present) and a one or high level otherwise.

Description of Channels 1 and 2

Comparators 1 and 2 are also linked and share a common output. A fault at either input will register as a one or high at OUT 1 & 2. Otherwise this output will be low. Each of these comparators also has a cold lamp test current. These comparators are intended for two lamp circuits which have a common fuse, and a fuse test line, similar to the brake-light test, is brought out.

A summary of the tests performed by each channel is given in Table I.

Signal Outputs

The signal outputs, OUT 1 & 2, OUT 3 & 4, OUT (3 \times 4), and OUT 5, are NPN collectors with pull-up currents provided by the power control section. These currents are about 75 μA each, and are intended to be sufficient to drive high level CMOS inputs.

Table I. Summary of Recommended Applications and Tests Performed for Each Channel

In a common automotive application, the AD22001 can be used to monitor the following lamps:

Channel	Recommended Applications	Tests Performed
1, 2	Fog Light Front Fog Light Rear Number Plate Light	I, II, III
3, 4	Low Beam Headlight Parking/Position Taillight	I, II, IV
5	Brake Light	I, III

The following tests are performed and status indicated with the AD22001:

Test	Description
I	Hot Lamp Test: Lamp is functional. Test performed while lamp is switched on.
II	Cold Lamp Test: Lamp is functional. Test performed while lamp is switched off.
III	Fuse is in place and functional.
IV	The two monitored light bulbs are powered simultaneously. This can be used as an implicit fuse test.

Threshold Biasing

The comparators are all activated by a common bias connection which controls their threshold voltage. The threshold is compensated for variations in temperature and operating voltage. The temperature compensation is approximately $+3770$ ppm/ $^{\circ}$ C. This causes the threshold to track the voltage across a copper shunt operated at constant current and varying temperature. The comparators are intended for use with small value shunts made using normal copper tracks on PC cards.

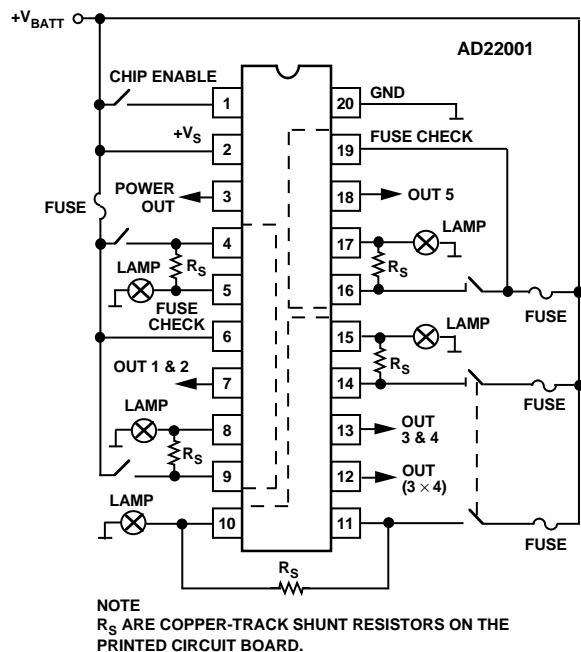

Figure 4. Application Suggestion

The power supply voltage compensation alters the comparator threshold with a 50% sensitivity around the nominal 13.5 V powering voltage. That is, a 10% change in battery voltage results in a 5% change in threshold voltage. This compensation approximately tracks the current in a hot lamp which typically varies nonlinearly with applied voltage, with approximately 50% sensitivity.

ON-OFF and Power Control

The AD22001 is intended to be powered directly from the battery voltage. In normal operation an internal switch connects internal circuits and the Power Out pin to the battery voltage, under control of the Chip Enable. When Chip Enable is high (above 9 V) the switch is on, the AD22001 is active and the Power Out pin will be close to battery potential. When Chip Enable is low, or open circuit, the switch will open and the AD22001 will be inactive and Power Out will go low.

In order to protect the external circuits connected to Power Out from overvoltage, the power switch is "soft" and limits the output voltage to typically 16 V. If the applied voltage exceeds this value, both Power Out and the internal voltage (from which the threshold is derived) will limit. The limited Power Out voltage will be available for moderate overvoltage conditions such as double battery. If the applied voltage goes above typically 33 V, the internal switch will be turned off, the lamp monitor circuits will be inactivated and Power Out will go low for the duration of the overvoltage.

Copper Resistors

Low value resistors can be produced as part of the printed circuit pattern on copper clad boards. These resistors will have a large positive TC, but this effect is compensated by the temperature sensitive threshold in the AD22001.

At a design temperature of 24° C the sheet resistance, ρ_s , of $35 \mu\text{m}$ copper cladding is about 0.5 milliOhms per square ($\text{m}\Omega/\text{sq}$), and $70 \mu\text{m}$ copper is about 0.25 $\text{m}\Omega/\text{sq}$. That is, a resistor made from $35 \mu\text{m}$ copper with an aspect ratio (length/width) of 1 will have a resistance of 0.5 $\text{m}\Omega$, while with an aspect ratio of 4 its resistance would be 2 $\text{m}\Omega$, etc. The resistor can be designed for a given value R by noting $R = \rho_s L/W$, so that $L = RW/\rho_s$.

The sheet resistance ρ_s is based on the thickness of copper cladding (with 1 ounce per square foot (oz./ft^2) copper at 0.0014" approx. equal to $35 \mu\text{m}$, and 2 oz./ft^2 copper at 0.0028" approx. equal to $70 \mu\text{m}$) and the temperature. Choosing the resistance value to correspond to the desired current trip level and AD22001 threshold at 22° C, the 24° C "round number" is convenient allowing a 2° C gradient from the resistor to the IC.

Choose W, the track width, as the larger of two values to be determined. First the conductor should be sized so that the nominal operating current results in only a small temperature rise. This can be determined from the table from MIL STD-275C, 9 Jan. 1970 (Figure 8).

Second, the width must be great enough to survive the peak currents which are allowed by the fuse which supplies the track. This can be determined from recommendations by the laminate manufacturer, or the MIL table.

Using the larger of the two values determined for W, the length of the resistor can be calculated. The resistor is defined by "Kelvin" connections to the ends which sense the voltage across this section of the track, and apply it to the differential input of the AD22001 comparator.

As an example, consider the case of a parking lamp which nominally draws 325 mA, and is on a circuit fused for 10A. Suppose the board uses $70 \mu\text{m}$ (2 oz.) copper cladding, then a conductor width of a few mils will suffice for the nominal current. However, the 10A fuse may allow as much as 13.5A current before it opens. A conductor 0.1" in width will carry 13.5A with less than 50° C rise in temperature, according to the table.

Selecting 1/2 the nominal current as the AD22001 trip level gives:

$$R = 1.75 \text{ mV}/(325 \text{ mA}/2)$$

$$\text{or } R = 10.769 \text{ m}\Omega.$$

Substituting these values in the expression for L,

$$L = 10.769 \text{ m}\Omega \times 0.1" / 0.25 \text{ m}\Omega \text{ per sq}$$

$$\text{or } L = 4.3".$$

A track of at least 0.1" in width should be used to convey this current anywhere on the board. A section 4.3" long should be sampled by Kelvin connections to the comparator differential inputs.

This case, where the peak current available is large while the sensed current is small, results in extremes of resistor length. In such cases it may be convenient to bend or fold the shunt

AD22001

resistance track. Bends in the track make the effective L/W more difficult to calculate, however, certain common cases have been evaluated.

To calculate the resistance of a track of width W with a 180° bend at radius $W/2$ resulting in a spacing W , add a resistance equivalent to 2.96 squares to account for the bend. Solving the resistance equation for L/W ,

$$L/W = R/\rho_S = 10.769 \text{ m}\Omega/0.25 \text{ m}\Omega/\text{sq},$$

or $L/W = 43$ squares.

Subtracting out the bend, the remainder is 40.04 squares. Converting this to linear dimensions gives 4.004" at $W = 0.1$ ".

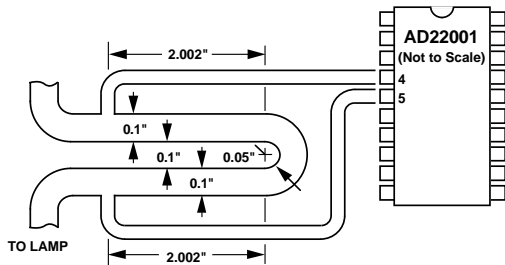

Figure 5. PCB Track Shunt Resistor with One 180° Bend

As shown in Figure 5, the contacts are made to the resistor section of the track at 2.002" from the bend. The bend has a uniform width of W , which is 0.1" in this case, and a radius of $W/2$. As a result, the aspect ratio of the straight sections plus the bend total 2.96 squares + $(2.002" + 2.002")/0.1$ or 43 squares.

The straight sections need not be of equal length, so long as they have the proper total, and the shorter one is longer than about $3W$. A shorter resistor can be made by using more bends and reducing the linear portion. For example, with three bends the total length of four linear sections would be:

$$(43 \text{ squares} - 3 \times 2.96 \text{ squares/Bend})W$$

$$\text{or } (43 - 8.88) \times 0.1" = 3.412".$$

Assuming equal linear sections, the contacts and the bends should be made at spacings of $3.412"/4 = 0.853$ ", as shown in Figure 6.

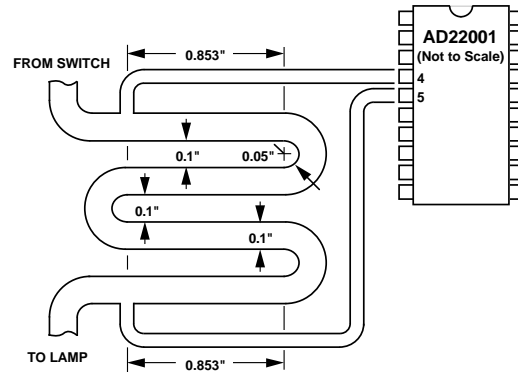

Figure 6. PCB Track Shunt Resistor with Two 180° Bends

A 90° bend with an inside radius of $W/2$ and a smooth width of W adds 0.341 squares to the aspect ratio as shown in Figure 7. Note that the linear measurements are differently made at the 90° and the 180° bend.

Other styles of bend can be used with minor variation in total resistance, however, we do not recommend the use of sharp inside corners on high current conductors in general and shunt resistors in particular. Sharp inside corners result in very high local current density and poor resistance repeatability.

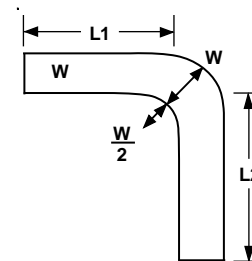

Figure 7. PCB Track Shunt Resistor with 90° Bend

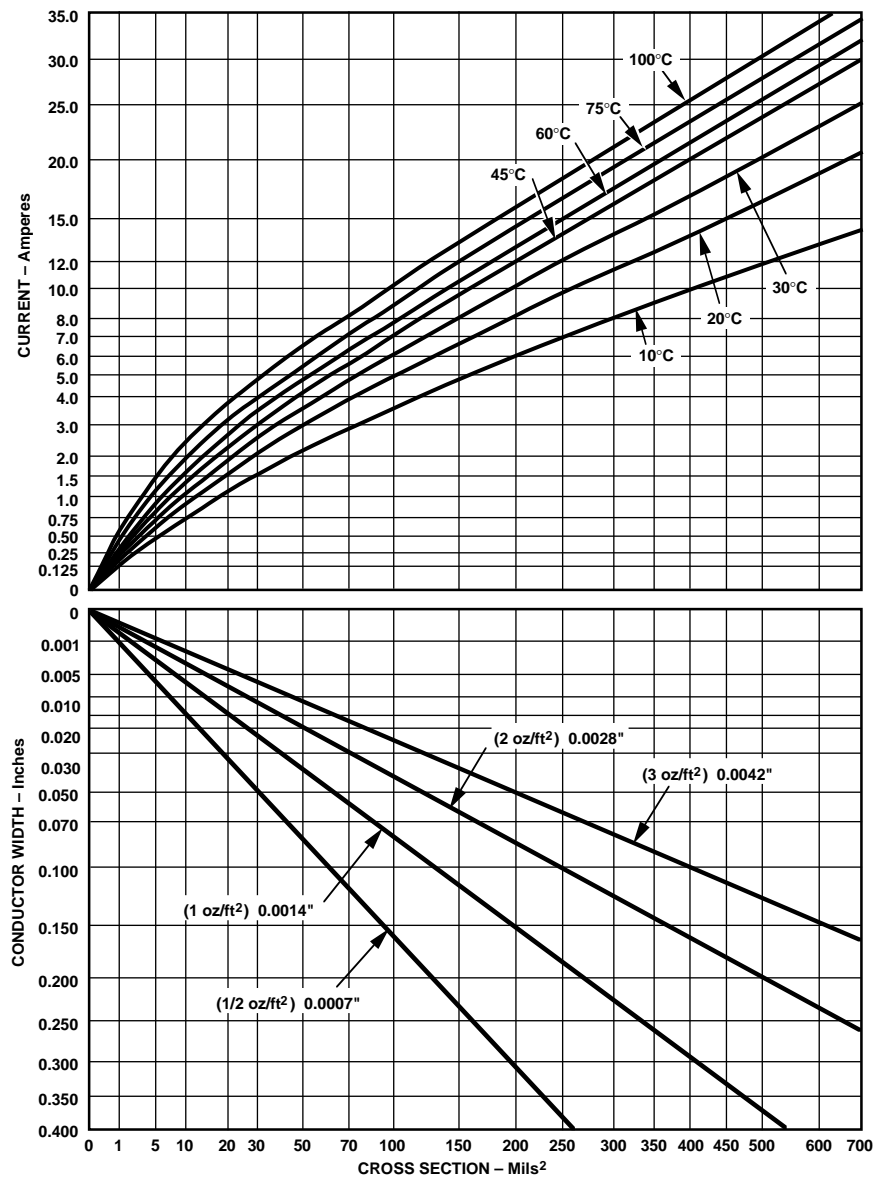
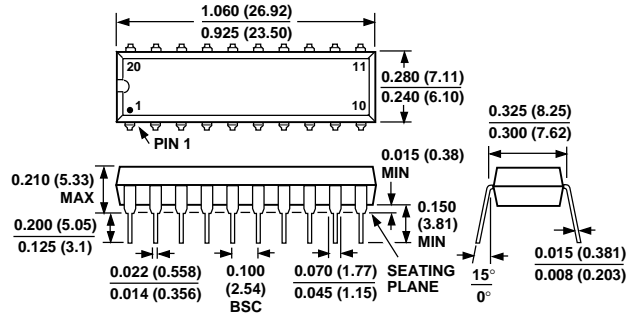

Figure 8. Current-Carrying Capacities and Sizes of Etched Copper Conductors for Various Temperature Rises Above Ambient (MIL-STD-275C, 9 January 1970)

OUTLINE DIMENSIONS

Dimensions shown in inches and (mm).

20-Pin Plastic DIP (N) Package



C1533-21-4/91

PRINTED IN U.S.A.



LittleDiode supplies new, hard to find or obsolete electronic components and semiconductors all over the world.

With over two million different components listed you are sure to find the part you need.

Feel free to visit us today at our online store:

LittleDiode.com

Looking forward to providing you with the best possible service.