

AD28msp01

FEATURES

Complete Analog I/O Port for DSP-Based FAX/MODEM Applications

Linear-Coded 16-Bit Sigma-Delta ADC

Linear-Coded 16-Bit Sigma-Delta DAC

On-Chip Anti-Alias and Anti-Image Filters

Digital Resampling/Interpolation Filter

7.2 kHz, 8.0 kHz, and 9.6 kHz Sampling Rates

8/7 Mode for 8.23 kHz, 9.14 kHz, and 10.97 kHz

Sampling Rates

Synchronous and Asynchronous DAC/ADC Modes

Bit and Baud Clock Generation

Transmit Digital Phase-Locked Loop for Terminal Synchronization

Independent Transmit and Receive Phase Adjustment

Serial Interface to DSP Processors

+5 V Operation with Power-Down Mode

28-Pin Plastic DIP/44-Lead PLCC/28-Lead SOIC

APPLICATIONS

High Performance DSP-Based Modems

**V.32ter, V.32bis, V.32, V.22bis, V.22, V.21,
Bell 212A, 103**

Fax and Cellular-Compatible Modems

V.33, V.29, V.27ter, V.27bis, V.27, V.26bis

Integrated Fax, Modem, and Speech Processing

GENERAL DESCRIPTION

The AD28msp01 is a complete analog front end for high performance DSP-based modems. The device includes all data conversion, filtering, and clock generation circuitry needed to implement an echo-cancelling modem with a single host digital signal processor. Software-programmable sample rates and clocking modes support all established modem standards. The AD28msp01 simplifies overall system design by requiring only +5 volts.

The inclusion of on-chip anti-aliasing and anti-imaging filters and 16-bit sigma-delta ADC and DAC ensures a highly integrated and compact solution for FAX or data MODEM applications. Sigma-delta conversion technology eliminates the need for complex off-chip anti-aliasing filters and sample-and-hold circuitry.

The AD28msp01 utilizes advanced sigma-delta technology to move the entire echo-cancelling modem implementation into the digital domain. The device maintains a -72 dB SNR throughout all filtering and data conversion. Purely DSP-based echo cancellation algorithms can thereby maintain robust bit error rates under worst-case signal attenuation and echo amplitude conditions. The AD28msp01's on-chip interpolation filter resamples the received signal after echo cancellation in the DSP, freeing the processor for other voice or data communications tasks.

REV. A

Information furnished by Analog Devices is believed to be accurate and reliable. However, no responsibility is assumed by Analog Devices for its use, nor for any infringements of patents or other rights of third parties which may result from its use. No license is granted by implication or otherwise under any patent or patent rights of Analog Devices.

FUNCTIONAL BLOCK DIAGRAM

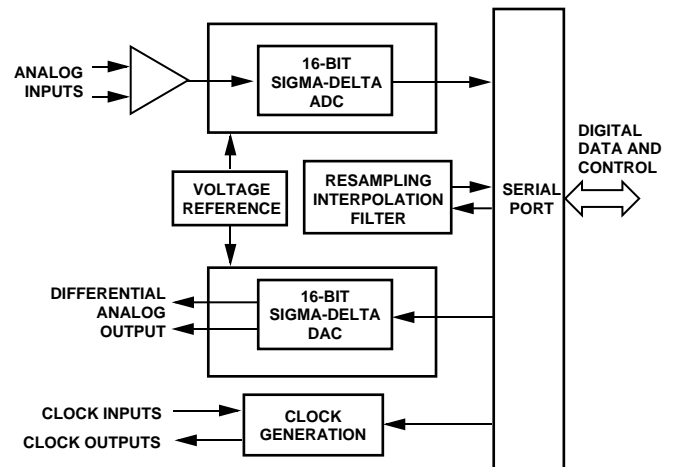

On-chip bit and baud clock generation circuitry provides for either synchronous or asynchronous operation of the transmit (DAC) and receive (ADC) paths. Each path features independent phase advance and retard adjustments via software control. The AD28msp01 can also synchronize modem operation to an external terminal bit clock.

The AD28msp01's serial I/O port provides an easy interface to host DSP microprocessors such as the ADSP-2101, ADSP-2105, and ADSP-2111. Packaged in a 28-pin plastic DIP, 44-lead PLCC, 44-pin TQFP, or 28-lead SOIC, the AD28msp01 provides a compact solution for space-constrained environments. The device operates from a +5 V supply and offers a low power sleep mode for battery-powered systems.

A detailed block diagram of the AD28msp01 is shown in Figure 1.

AD28msp01

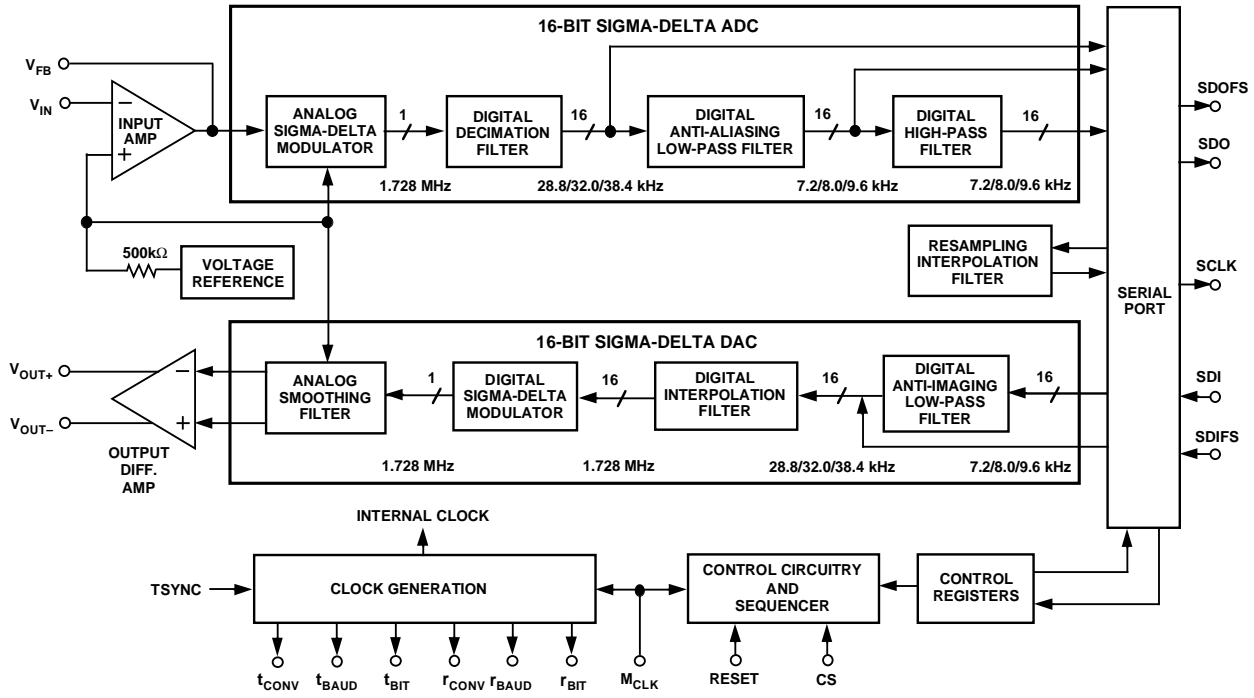

Figure 1. AD28msp01 Block Diagram

PIN DESCRIPTIONS

Name	Type	Description
Analog Interface		
V _{IN}	I	Analog input to the inverting terminal of the input amplifier.
V _{FB}	O	Feedback terminal of the input amplifier.
V _{OUTP}	O	Analog output from the noninverting terminal of the output differential amplifier.
V _{OUTN}	O	Analog output from inverting terminal of the output differential amplifier.
Serial Interface		
SCLK	O/Z	Serial clock used for clocking data or control bits to/from the serial port (SPORT). The frequency of this clock is 1.7280 MHz. This pin is 3-stated when the CS is low.
SDI	I	Serial data input of the SPORT. Both data and control information are input on this pin. This pin is ignored when CS is low.
SDO	O/Z	Serial data output of the SPORT. Both data and control information are output on this pin. This pin is 3-stated when CS is low.
SDIFS	I	Framing synchronization signal for serial data transfers to the AD28msp01 (via the SDI pin). This pin is ignored when CS is low.

Name	Type	Description
SDOFS	O/Z	Framing synchronization signal for serial data transfers from the AD28msp01 (via the SDO pin). This pin is 3-stated when CS is low.
Clock Generation		
TSYNC	I	Transmit synchronization clock. This signal is used to synchronize the transmit clocks and the converter clocks to an external terminal/bit-rate clock. It is used in the V.32 TSYNC and Asynchronous TSYNC modes and is ignored in other operating modes. The frequency of the external clock must be programmed in Control Register 0. This pin must be tied high or low if it is not being used.
TBIT	O	Transmit bit rate clock. This is an output clock whose frequency is programmable via Control Register 3. It is synchronized with the TCONV clock.
TBAUD	O	Transmit baud rate clock. This is an output clock whose frequency is programmable via Control Register 3. It is synchronized with the TCONV clock.

PIN DESCRIPTIONS (Continued)

Name	Type	Description
TCONV	O	Transmit conversion clock. This clock indicates when the ADC has finished a sampling cycle. The frequency of TCONV is programmed by setting the sample rate field in Control Register 0. The programmed TCONV rate can be scaled by a factor of 8/7 by setting Bit 9 in Control Register 1. The phase of TCONV can be adjusted by writing the Transmit Phase Adjust Register (Control Register 5).
RBIT	O	Receive bit rate clock. This is an output clock whose frequency is programmable via Control Register 2. It is synchronized with the RCONV clock.
RBAUD	O	Receive baud rate clock. This is an output clock whose frequency is programmable via Control Register 2. It is synchronized with the RCONV clock.
RCONV	O	Receive conversion clock. This clock indicates when the DAC has finished a sampling cycle. The frequency of RCONV is programmed by setting the sample rate field in Control Register 0. The programmed RCONV rate can be scaled by a factor of 8/7 by setting Bit 9 in Control Register 1. The phase of RCONV can be adjusted by writing the Receive Phase Adjust Register (Control Register 4).
Miscellaneous		
MCLK	I	AD28msp01 master clock input. The frequency of this clock must be 13.824 MHz to guarantee listed specifications.
RESET	I	Active-low chip reset. This signal sets all AD28msp01 control registers to their default values and clears the device's digital filters. SPORT output pins are 3-stated when $\overline{\text{RESET}}$ is low. SPORT input pins are ignored when $\overline{\text{RESET}}$ is low.
CS	I	Active-high chip select. This signal 3-states all SPORT output pins and forces the AD28msp01 to ignore all SPORT input pins. If CS is deasserted during a serial data transfer, the 16-bit word being transmitted is lost.
Power Supplies		
V _{CC}		Analog supply voltage (nominally +5 V)
GND _A		Analog ground
V _{DD}		Digital supply voltage (nominally +5 V)
GND _D		Digital ground

FUNCTIONAL DESCRIPTION

A/D Conversion

The A/D conversion circuitry of the AD28msp01 consists of an analog input amplifier and a sigma-delta analog-to-digital converter (ADC). The analog input signal to the AD28msp01 must be ac coupled.

Analog Input Amplifier

The analog input amplifier is internally biased by an on-chip voltage reference in order to allow operation of the AD28msp01 with a +5 V power supply.

Input signal level to the sigma-delta modulator should not exceed V_{INMAX}, which is specified under "Analog Interface Electrical Characteristics." Refer to "Analog Input" in the "Design Considerations" section of this data sheet for more information.

ADC

The ADC consists of a 3rd-order analog sigma-delta modulator, a decimation filter, an anti-aliasing low-pass filter, and a high-pass filter. The analog input is applied to the input amplifier. The output of this amplifier is applied to an analog sigma-delta modulator which noise-shapes it and produces 1-bit samples at a 1.7280 MHz rate. This bit stream is fed to the decimation filter, which increases the resolution to 16-bits and decreases the sampling frequency. The parallel data stream is then processed by the anti-aliasing low-pass filter which further reduces the sampling rate. Finally, the high-pass filter removes input frequency components at the low end of the spectrum.

Either the high-pass filter alone or the high-pass/anti-aliasing low-pass filter combination can be bypassed by setting the appropriate bits in Control Register 1, thus producing samples at 7.2/8.0/9.6 kHz or 28.8/32.0/38.4 kHz, respectively. The gain and the frequency response of the AD28msp01 are altered when these filters are bypassed. The DSP processor that receives samples from the AD28msp01 may need to compensate for this change.

Decimation Filter

The decimation filter is a sinc⁴ digital filter that increases resolution to 16 bits and reduces the sample rate to 28.8, 32.0, or 38.4 kHz (depending on the input sample rate). The 16 bit, parallel data stream output of the decimation filter is then processed by the anti-aliasing low-pass filter.

Anti-Aliasing Low-Pass Filter

The anti-aliasing low-pass filter further reduces the sampling rate by a factor of four to 7.2 kHz, 8.0 kHz, or 9.6 kHz (depending on the output sample rate of the decimation filter). The output is fed to the high-pass filter. The low-pass/high-pass filter combination can be bypassed by setting the appropriate bits in Control Register 1. If the filters are bypassed, the signal must be scaled by the following multipliers to achieve normal levels: 2.046 for 9.6 kHz, 0.987 for 8.0 kHz, and 0.647 for 7.2 kHz.

When the filters are bypassed, the host DSP must be able to receive data at the 28.8/32.0/38.4 kHz rates. In this case, resampling interpolation should be disabled because of insufficient bandwidth to transmit both ADC and resampled data to the SPORT.

High-Pass Filter

The digital high-pass filter removes frequency components at the low end of the spectrum. The high pass filter can be bypassed by setting the appropriate bits in Control Register 1.

AD28msp01

The output of the ADC is transferred to the AD28msp01's serial port (SPORT) for transmission to the host DSP processor.

D/A CONVERSION

The D/A conversion circuitry of the AD28msp01 consists of a sigma-delta digital-to-analog converter (DAC) and a differential output amplifier.

DAC

The DAC consists of an anti-imaging low-pass filter, an interpolation filter, a digital sigma-delta modulator, and an analog smoothing filter. These filters have the same characteristics as the ADC's anti-aliasing filter and decimation filter.

The DAC receives 16-bit samples from the host DSP processor via AD28msp01's SPORT. If the host processor fails to write a new value to the serial port, the existing (previous) data is read again. The data stream is filtered first by the DAC's anti-imaging low-pass filter and then by the interpolation filter. The output of the interpolation filter is fed to the DAC's digital sigma-delta modulator, which converts the 16-bit data to 1-bit samples. The output of the sigma-delta modulator is fed to the AD28msp01's analog smoothing filter where it is converted into a low-pass filtered, analog voltage.

Anti-Imaging Low-Pass Filter

The anti-imaging low-pass filter filters the 7.2 kHz, 8.0 kHz, or 9.6 kHz data stream from the SPORTs, and raises the sampling rate to 28.8 kHz, 32.0 kHz, or 38.4 kHz.

The anti-imaging low-pass filter can be bypassed by setting the appropriate bit in Control Register 1. This results in a gain change. If the filter is bypassed, the signal must be scaled by the following multipliers to achieve normal levels: 2.046 for 9.6 kHz, 0.987 for 8.0 kHz, and 0.647 for 7.2 kHz.

When the filter is bypassed, the host DSP must be able to transmit data at the 28.8/32.0/38.4 kHz rates. In this case, re-sampling interpolation should be disabled because of insufficient bandwidth to transmit both ADC and resampled data to the SPORT.

Interpolation Filter

The interpolation filter contains a sinc⁴ digital filter which raises the sampling rate to 1.7280 MHz by interpolating between the samples. These 16-bit samples are then processed by the digital sigma-delta modulator which noise-shapes the data stream and reduces the sample width to a single bit stream.

Analog Smoothing Filter

The AD28msp01's analog smoothing filter consists of a 2nd-order Sallen-Key continuous-time filter and a 3rd-order switched capacitor filter. The Sallen-Key filter has a 3 dB point at approximately 80 kHz.

The analog smoothing filter converts the 1.7280 MHz bit stream output of the sigma-delta modulator into a low-pass filtered, differential analog signal.

Differential Output Amplifier

The differential output amplifier produces the AD28msp01's analog output (V_{OUTP} , V_{OUTN}). It can drive loads of 2 k Ω or greater and has a maximum differential output voltage swing of 6.312 V peak-to-peak. The output signal is dc biased to the AD28msp01's on-chip voltage reference (2.5 V nominal) and can be ac coupled directly to a load or dc coupled to an external

amplifier. Refer to "Analog Output" in the "Design Considerations" section of this data sheet for more information.

The V_{OUTP} and V_{OUTN} outputs must be used as differential outputs; do not use either as a single-ended output.

SERIAL PORT

The AD28msp01 includes a full-duplex synchronous serial port (SPORT) used to communicate with a host processor. The SPORT is used to read and write all data and control registers in the AD28msp01. The SPORT transfers 16-bit words, MSB first, at a serial clock rate of 1.7280 MHz.

When the AD28msp01 exits reset, both the analog circuitry and the digital circuitry are powered down. The serial port will not transmit data to the host until the host sets the digital power-down bit (PWDD) to 1 in Control Register 1. All control registers should be initialized before this bit is set.

The SPORT is configured for an externally generated receive frame sync (SDIFS), an internally generated serial clock (SCLK), and an internally generated transmit frame sync (SDOFS). The host processor should be configured for an external serial clock and receive frame sync and an internal transmit frame sync.

DSP Processor Interface

The AD28msp01-to-host processor interface is shown in Figure 2.

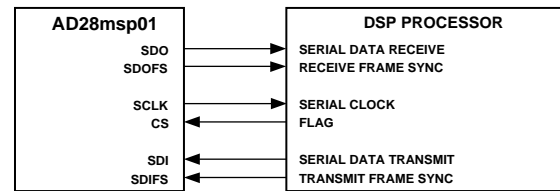

Figure 2. AD28msp01-to-DSP Processor Interface

The AD28msp01's chip select (CS) must be held high to enable SPORT operation. CS can be used to 3-state the SPORT pins and disable communication with the host processor.

To use the ADSP-2101 or ADSP-2111 as host DSP processor for the AD28msp01, refer to Figure 3.

Note that the ADSP-2101's SPORT0 communicates with the AD28msp01's SPORT while the ADSP-2101's Flag Output (FO) is used to signal the AD28msp01's CS input. SPORT1 on the ADSP-2101 must be configured for flags and interrupts in this system.

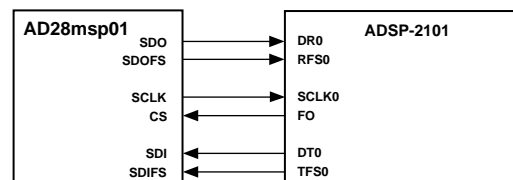

Figure 3. AD28msp01-to-ADSP-2101 Interface

Figure 4 shows an ADSP-2101 assembly language program that initializes the AD28msp01 and implements a digital loopback through the processor.

```

{This ADSP-2101 program initializes the AD28msp01}
{and executes a loopback, or talk-through, routine.}

. MODULE/RAM/BOOT = 0 MSP01;
. VAR/DM/CIRC rec[2];                               {Receive word buffer}
. VAR/DM/CIRC trans[2];                             {Transmit word buffer}
                                                    {Interrupt Vectors}

rset:        JUMP start;
            RTI; RTI; RTI;

irq2v:      RTI; RTI; RTI; RTI;

sprt0t:     AX0 = 0x25; DM(0x3ff3) = AX0;             {Disable TX autobuffer}
            RTI; RTI;

sprt0r:     JUMP receive;
            RTI; RTI; RTI;

sprt1t:     RTI; RTI; RTI; RTI;
sprt1r:     RTI; RTI; RTI; RTI;
timerv:     RTI; RTI; RTI; RTI;

                                                    {Initialize DAGs}

start:

            I2 = ^rec;
            L2 = %rec;
            I3 = ^trans;
            L3 = %trans;
            M0 = 0;
            M1 = 1;
            S1 = 0;
            DM(0x3000) = SI;                         {Reset the AD28msp01}
                                                    {Initialize the ADSP-2101}

init_dsp:

            AX0 = 0x2a0f;                             {Ext RFS, Int TjS, Ext SCLK, SLEN = 15}
            DM(0x3ff6) = AX0;                         {SPORT0 control register}
            AX0 = 0x101f;                             {Enable SPORT0}
            DM(0x3fff) = AX0;                         {System control register}

                                                    {Initialize AD28msp01 control register}
                                                    {Note: This section could be autobuffered.}
                                                    {Enable SPORT0 TX interrupt}

init_msp01:

            IMASK = 0x10;
            AR = 0;
            CNTR = 6;
            DO initi UNTIL CE;
                TX0 = AR;                             {Transmit address}
                IDLE;
                TX0 = SI;                             {Transmit control word}
                IDLE;
                AY0 = AR;
            initi:  AR = AY0 + 1;                       {Increment address}

            AX1 = 1;
            AR = 0x18;                                 {Power up AD28msp01}
            TX0 = AX1;
            IDLE;
            TX0 = AR;
            AR = B#0025;
            DM(0x3ff3) = AR;                           {Enable RX autobuffering with I2, M1}
            IMASK = 0x18;                             {Autobuffer control register}
            JUMP wait;                                 {Enable RX and TX interrupt}
                                                    {Wait for receive interrupt}
                                                    {Receive Interrupt Routine}

wait:      JUMP wait;

receive:

            DM(0x3ff3) = SI;                           {Disable autobuffering}
            AX1 = DM(I2, M1);                          {Read first receive word from buffer}

```

AD28msp01

```

                                AX0 = DM(I2, M1);           {Read data word}
                                AY0 = 8;                   {Verify AD28msp01 address = 8}
                                AR = AX1 - AY0;
                                IF EQ JUMP goodstuff;
                                RTI;

goodstuff;

                                MODIFY (I3, M1);           {Point to second word of TX buffer}
                                DM(I3, M0) = AX0;
                                MX1 = 6;                   {Load address word into MX1}
                                AR = 0x06a7;               {Enable TX and RX autobuffer}
                                DM(0x3ff3) = AR;           {Write to SPORT control Register}
                                TX0 = MX1;                   {Autobuffer start}
                                RTI;

.ENDMOD;

```

Figure 4. AD28msp01 Initialization and ADSP-2101 Loopback Routine

Serial Data Output

When the digital power-down bit ($\overline{\text{PWDD}}$) of Control Register 1 is set to 1, the AD28msp01's SPORT begins transmitting data to the host processor. All transfers between the host processor and the AD28msp01 consist of a serial data output frame sync (SDOFS) followed by a 16-bit address word, then a second frame sync followed by a 16-bit data word. Address/data word pairs are transmitted whenever they become available. The ADC takes precedence over the Interpolator output data. If a new word becomes available while a serial transfer is in progress, the current serial transfer is completed before the new word starts transmission.

Serial Data Input

The host processor must initiate data transfers to the AD28msp01 by asserting the serial data input frame sync (SDIFS) high. Each of the 16-bit address word and 16-bit data word transfers begins one serial clock cycle after SDIFS is asserted. The address word always precedes the data word. The second serial data input frame sync for the data word can be asserted as early as the last bit of the address word is transmitted, or any time after.

The host processor must assert SDIFS shortly after the rising edge of SCLK and must maintain SDIFS high for one cycle because SDIFS is clocked by the SCLK falling edge. Data is then driven from the host processor shortly after the rising edge of the next SCLK and is clocked into the AD28msp01 on the falling edge of SCLK in that cycle. Each bit of a 16-bit address and 16-bit data word is thus clocked into the AD28msp01 on the falling edge of SCLK (MSB first).

If SDIFS is asserted high again before the end of the present data word transfer, it is not recognized until the falling edge of SCLK in the last (LSB) cycle.

When the serial port receives an interpolator or DAC input word, it writes the value to an internal register which is read by the AD28msp01 when it is needed. This allows the host to send data words at any time during the sample period.

NOTE: Exact SPORT timing requirements are defined in the "Specifications" section of this data sheet.

Clock Generation

The AD28msp01 generates all transmit and receive clocks necessary to implement standard voice-grade modems. The AD28msp01 can generate six different clock signals for transmit

and receive timing as well as an additional clock signal for serial port timing.

The receive clocks are the RCONV, RBIT and RBAUD signals. The individual clock rates are programmable and are all synchronized with RCONV.

The transmit clocks are the TCONV, TBIT and TBAUD signals. The individual clock rates are programmable and are all synchronized with TCONV.

Depending on the operating mode, the converter clocks can be synchronized to an external clock signal (TSYNC) or can be generated internally. The clocks can be adjusted in phase by setting the appropriate phase adjust register. All the AD28msp01 Bit/Baud clocks have a 50% duty cycle except the 1600 Hz baud rate. This baud rate has a 33%–66% duty cycle.

Resampling Interpolation Filter

The resampling interpolation filter interpolates the data from the TCONV rate to 1.7280 MHz. The data is then resampled (decimated) in phase with the RCONV clock. The frequency response characteristics of the resampling interpolation filter are identical to the frequency response characteristics of the anti-imaging, low-pass filter/interpolation filter combination.

Figure 5 illustrates the effects of a resampling interpolation filter.

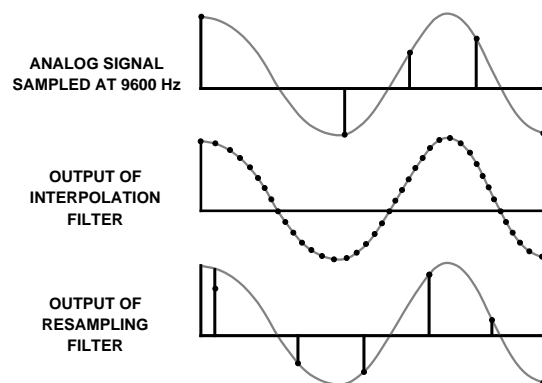

Figure 5. Effects of Interpolation Filter

Since the resample phase is locked to RCONV, it can be advanced or slipped by writing a signed-magnitude value to the Receive Phase Adjust Register (Control Register 2). The phase advance or slip is equal to the master clock period (13.824 MHz) multiplied by the signed-magnitude 9-bit value in Control Register 4.

The change in phase requires a maximum of two RCONV cycles to complete. If the value written to Control Register 4 is less than the oversampling ratio, then the change will complete in one RCONV cycle.

Control Registers

The AD28msp01's six control registers configure the device for various operating modes including filter bypass and power-down. The AD28msp01's host processor can read and write to

the control register through the AD28msp01's serial port (SPORT).

The control registers should be set up for the desired mode of operation before bringing the AD28msp01 out of power-down (by writing ones to the PWDA and PWDD bits in Control Register 1).

The control registers are cleared (set to 0x0000) when the AD28msp01 is reset.

The sampling rate should be set before writing ones to the power-down bits. Changing the sampling rate at any other time will force a soft reset. For more information about soft resets, refer to the end of this section of the data sheet.

NOTE: Reserved bits should always be cleared to 0.

Control Register 0 address = 0x00

This register is used to:

- Enable/disable the resampling interpolation filter
- Set the external TSYNC clock rate
- Select the sampling rate
- Select the operating mode

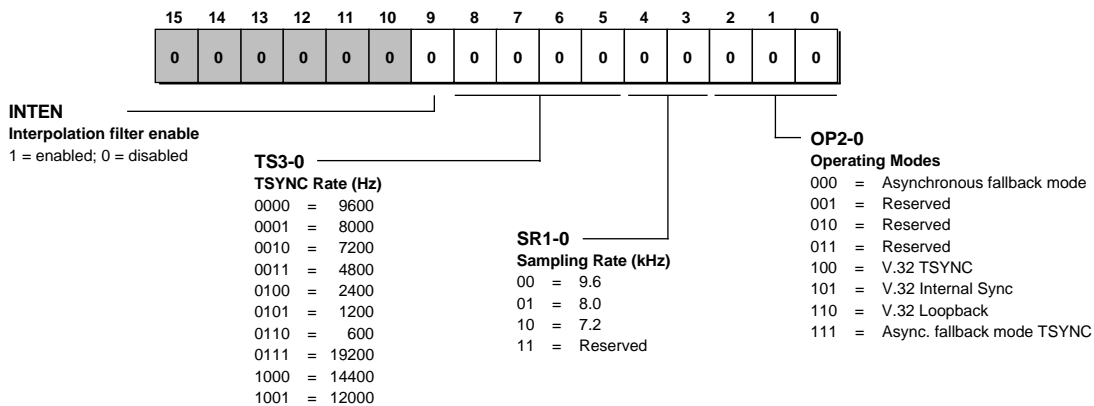

Control Register 1 address = 0x01

This register is used to:

- Increase the sampling rate to 8/7 the rate selected in Control Register 0
- Power down the device
- Bypass the digital filters

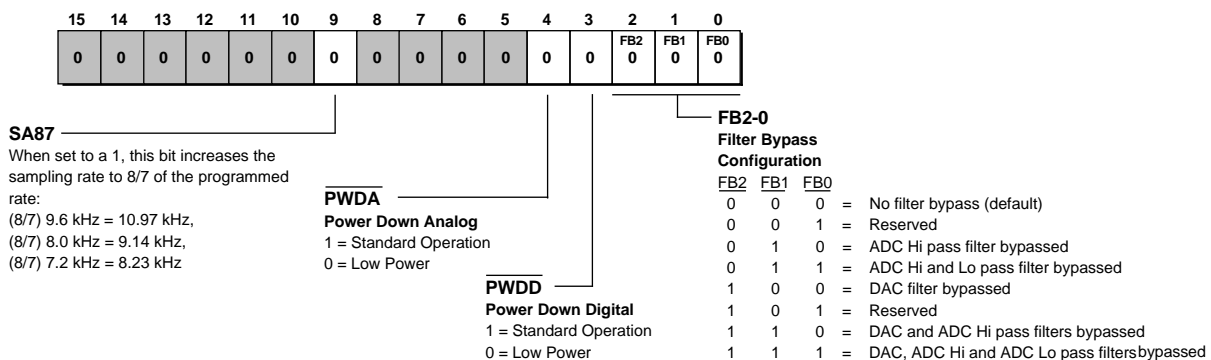

AD28msp01

If any low-pass filter is bypassed, the resampling interpolation filter should be disabled (in Control Register 0.)

Control Register 2 address = 0x02

This register is used to:

- Select the frequency of the Receive baud clock (RBAUD)
- Select the frequency of the Receive bit clock (RBIT)

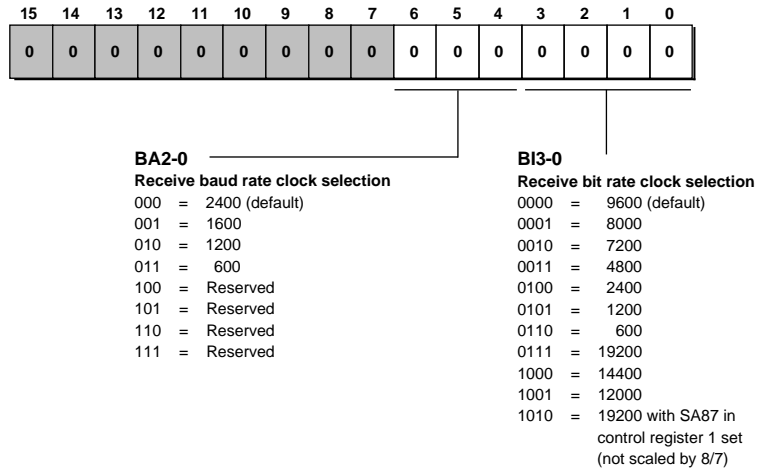

Control Register 3 address = 0x03

This register is used to:

- Select the frequency of the Transmit baud clock (TBAUD)
- Select the frequency of the Transmit bit clock (TBIT)

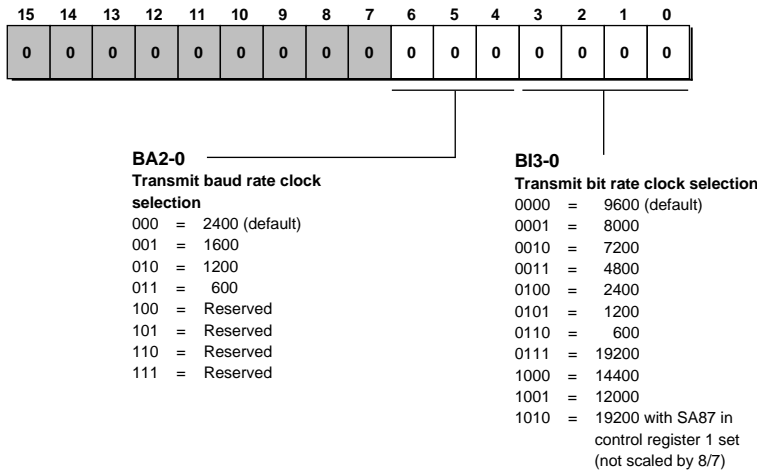

Control Register 4 address = 0x04

This register is the *Receive Phase Adjust Register* and it is used to:

- Change the phase of the receive clocks (RBAUD, RBIT, RCONV)

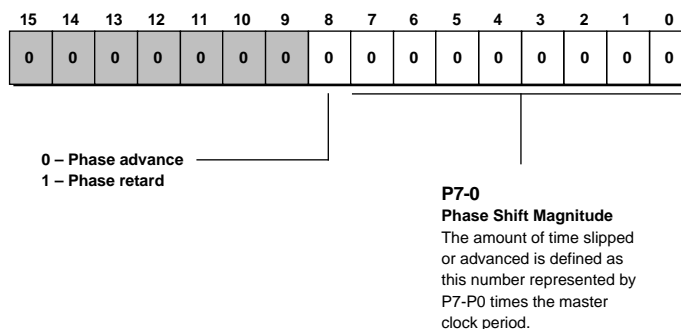

Once you have written a value to the register, subsequent writes are ignored until the register is finished incrementing/decrementing to zero.

The phase advance or slip is equal to the master clock period (13.824 MHz) multiplied by the signed-magnitude 9-bit value in Control Register 4. The AD28msp01 decrements Control Register 4 as it adjusts the phase of RCONV. Control Register 4 will equal zero when the phase shift is complete.

Control Register 5 address = 0x05

This register is the *Transmit Phase Adjust Register* and it is used to:

- Change the phase of the Transmit clocks (TBAUD, TBIT, TCONV)

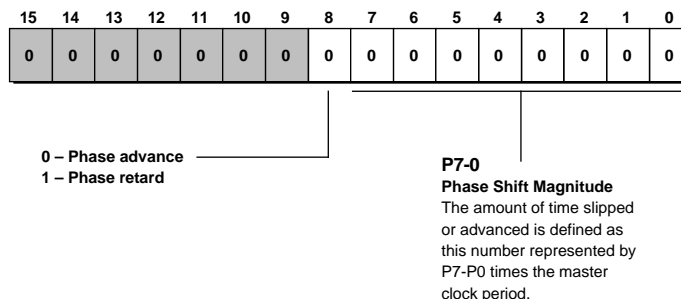

This register must be equal to zero before its value can be changed. Once you have written a value to the register, subsequent writes are ignored until the register is finished incrementing/decrementing to zero.

The phase advance or slip is equal to the master clock period (13.824 MHz) multiplied by the signed-magnitude 9-bit value in Control Register 5. The AD28msp01 decrements Control Register 5 as it adjusts the phase of TCONV. Control Register 5 will equal zero when the phase shift is complete.

Soft Resets

Certain conditions cause the AD28msp01 to perform a *soft reset*; the DSP is reset but the control register values do not change.

Table I shows when a soft reset is caused by changing the values of certain control register bits while the device is operating. When these bits are modified, the AD28msp01 will perform a soft reset and start up again in the new configuration. Reserved bits in the control registers should always be set to zero.

Table I. Soft Reset

Bits	Configures
Control Register 0, SR1–SR0	Sampling rate
Control Register 0, OP2–OP0	Clock generation operating modes (async-to-V.32 or V.32-to-async)
Control Register 0, TS3–TS0	TSYNC rate
Control Register 1, FB2–FB0	Filter bypass configuration
Control Register 1, SA87	Sampling rate scaling by 8/7

Data Registers

The AD28msp01 contains four data registers.

Data Register 0 address = 0x06

DAC Input Register (write-only): The 16-bit twos complement values written to this register are input to the AD28msp01's digital-to-analog converter.

AD28msp01

Data Register 1 address = 0x07

Interpolation Filter Input Register (write-only): The 16-bit twos complement values written to this register are input to the resampling interpolation filter.

Data Register 2 address = 0x08

ADC Output Register (read-only): The 16-bit twos complement values read from this register are the output of the AD28msp01's analog-to-digital converter.

Data Register 3 address = 0x09

Interpolation Filter Output Register (read-only): The 16-bit twos complement values read from this register are the output of the resampling interpolation filter.

Addresses 0x0A—0x1F are reserved.

Table II contains the register addresses.

Table II. Register Addresses

Address Bits 4–0	Register	Description
00000	Control Register 0	Data rate and synchronization rate selects, interpolation filter enable
00001	Control Register 1	Filter bypass, test, power-down mode bits, V.32ter mode select bits
00010	Control Register 2	ADC bit and baud rate selects
00011	Control Register 3	DAC bit and baud rate selects
00100	Control Register 4	Receive phase adjust
00101	Control Register 5	Transmit phase adjust
00110	Data Register 0	DAC input register
00111	Data Register 1	Interpolation filter input register
01000	Data Register 2	ADC output register
01001	Data Register 3	Interpolation filter output register
01010	Reserved	
.....	
.....	
11111	Reserved	

Transferring Data and Control Words to the AD28msp01

Data and control word transfers to the AD28msp01 can only be initiated by the host processor. When transferring data to the AD28msp01, the host processor specifies the destination register by first transmitting a 16-bit address word (Figure 6) and then transmitting the 16-bit data word. The read/write bit in the address word must be deasserted. The serial data stream from the host processor will consist of a sequence of alternating address and data words. The AD28msp01 will not write the target register until both the address word and data word are completely transferred.

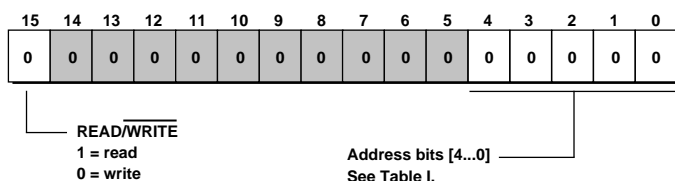

Figure 6. Address Word

Example

Transferring the following 16-bit words to the AD28msp01 will initialize Control Registers 0–3.

Word Transferred	Description
0x0000	Control Register 0 Address Word
0x0254	Write this value to Control Register 0
0x0002	Control Register 2 Address Word
0x0031	Write this value to Control Register 2
0x0003	Control Register 3 Address Word
0x0032	Write this value to Control Register 3
0x0001	Control Register 1 Address Word
0x0018	Write this value to Control Register 1

Note that in this example the power-down bits in Control Register 1 are released (set to 1) only after the AD28msp01 is fully configured by writing to Control Registers 0, 2, and 3.

Transferring Data from the AD28msp01 to the Host

Data transfers to the host processor can only be initiated by the AD28msp01. When transferring data the AD28msp01 first specifies the source register by transferring a 16-bit address word and then transfers the contents of the source register. Bits 5–14 of the address word will always be forced to zero. When transferring data, the serial data stream from the AD28msp01 will consist of a sequence of alternating address and data words.

Transferring Control Words from the AD28msp01 to the Host

All control registers in the AD28msp01 are host-readable. To read a control register, the host must transmit a 16-bit address word with the Read/Write bit set, then transmit a dummy data word. The AD28msp01 will respond by first completing any AD28msp01-to-Host transfer in progress. As soon as the dummy data word is received, the device will transfer a 16-bit word with the control register address and then transmit the contents of the control register.

Example

The following data streams show how a host can read the contents of an AD28msp01 control register:

Host Transfer	AD28msp01 Transfer	Description
0x8001		Read Control Register 1
0x1234		Dummy data word
	0x_____	AD28msp01 completes data
	0x_____	Transfer in progress
	0x0001	Address word
	0x0023	Contents of Control Register 1

Serial Port Timing

All serial transfers are synchronous. The receive data (SDI) and receive frame sync (SDIFS) are clocked into the device on the falling edge of SCLK. The receive frame sync (SDIFS) must be asserted one SCLK cycle before the first data bit is transferred. When receiving data, the AD28msp01 ignores the receive frame sync pin until the least significant bit is being received.

When transmitting data, the AD28msp01 asserts transmit frame sync (SDOFS) and transmit data (SDO) synchronous with the rising edge of SCLK. Transmit frame sync is transmitted one SCLK cycle before the first data bit is transferred.

Operating Modes

The AD28msp01 is capable of operating in several different modes, as described below.

V.32 TSYNC Mode

In V.32 TSYNC Mode, shown in Figure 7, the AD28msp01's transmit circuitry is synchronized to an external TSYNC signal. The AD28msp01 receive circuitry is sampled synchronous to the transmit circuitry, but the data can be resampled at a different phase by using the resampling interpolation filter.

TCONV, TBIT and TBAUD are generated internally but are phase-locked to the external TSYNC input signal with the digital phase-locked loop. RCONV, RBIT and RBAUD are generated internally (but frequency locked to TSYNC) and can be phase adjusted with the Receive Phase Adjust Register (Control Register 4).

TCONV initiates a new DAC sample update, loads the ADC register (Data Register 2), and loads the DAC register (Data Register 0) with a new sample.

The digital resampling interpolation filter can be used for digital resampling of the received signal. Enable this function by setting Bit 9 in Control Register 0. The phase of the resampled signal is adjusted with the Receive Phase Adjust Register. Samples are loaded into the interpolator at the TCONV rate and are resampled at the RCONV rate.

When entering V.32 TSYNC Mode, RCONV is locked to TCONV before TCONV is locked to TSYNC. If this mode is entered from a non-V.32 mode, the device performs a soft reset.

The time required to lock TCONV to RCONV is dependent on the phase difference between RCONV and TCONV when entering the mode.

This mode is entered by setting the Operating Mode field in Control Register 0. The RCONV/TCONV rate can be set to 9.6 kHz, 8.0 kHz or 7.2 kHz by setting the sample rate bit field in Control Register 0. The TBIT and TBAUD clock rates are set by adjusting the appropriate bits in Control Register 3. The RBIT and RBAUD clock rates are set by adjusting the appropriate bits in Control Register 2. The bit rates, baud rates and TSYNC rate can be set to any combination of clock rates listed in the control register descriptions. The TSYNC field on Control Register 0 must be set to the frequency of the input pin.

Example

Transferring the following word sequence to the AD28msp01 will configure the device for V.32 TSYNC Mode at the clock rates indicated:

Word Transferred	Description
0x0000	Control Register 0 address word
0x0254	Enable interpolation filter, TSYNC = 7200, sample rate = 7200, mode = V.32 TSYNC
0x0002	Control Register 2 address word
0x0002	RBAUD = 2400, RBIT = 7200
0x0003	Control Register 3 address word
0x0023	TBAUD = 1200, TBIT = 4800
0x0001	Control Register 1 address word
0x0018	Configure and power-up device

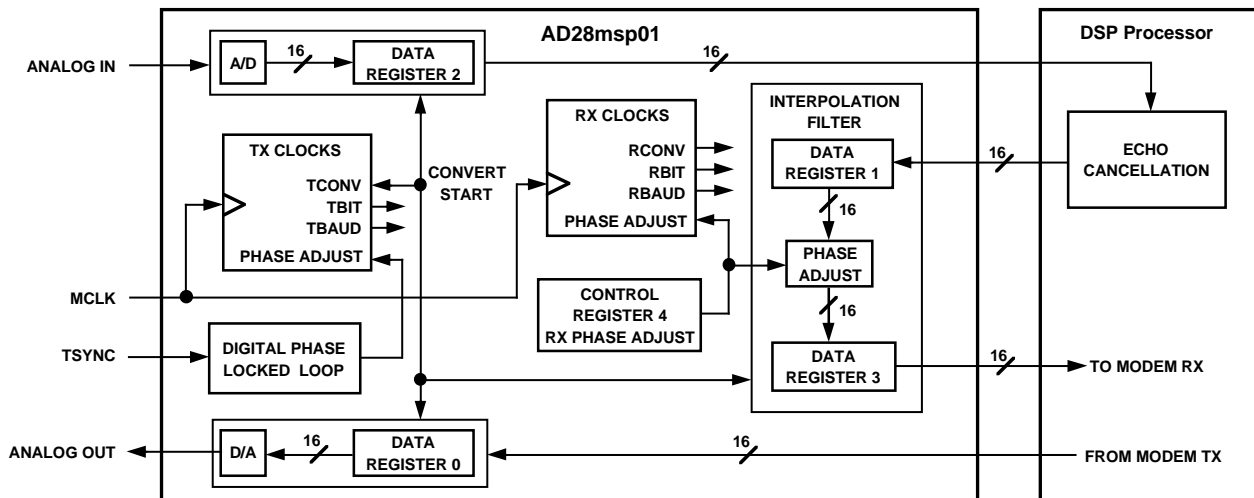

Figure 7. V.32 TSYNC Mode Block Diagram

AD28msp01

V.32 Internal Sync Mode

In V.32 Internal Sync Mode, shown in Figure 8, the AD28msp01's transmit clocks are generated internally. The receive circuitry operates synchronous to the transmit circuitry, but the data can be resampled at a different phase through the resampling interpolation filter.

TCONV, TBIT and TBAUD are generated internally and can be phase adjusted with the Transmit Phase Adjust Register (Control Register 5). RCONV, RBIT and RBAUD are also generated internally and can be phase adjusted with the Receive Phase Adjust Register (Control Register 4).

TCONV initiates a new ADC sample update, loads the ADC register (Data Register 2), and loads the DAC register (Data Register 0) with a new sample.

The digital resampling interpolation filter can be used for digital resampling of the received signal. Enable this function by setting Bit 9 in Control Register 0. The phase of the resampled signal is

adjusted with the Receive Phase Adjust Register. Samples are loaded into the interpolator at the TCONV rate and are resampled at the RCONV rate.

When entering V.32 Internal Sync Mode, RCONV is first locked to TCONV. RCONV is then phase adjusted whenever a new value is written to the Receive Phase Adjust Register (Control Register 4). If this mode is entered from a non-V.32 mode, the device performs a soft reset. The time required to lock TCONV to RCONV is dependent on the phase difference between RCONV and TCONV when entering the mode.

This mode is entered by setting the Operating Mode field in Control Register 0. The RCONV/TCONV rate can be set to 9.6 kHz, 8.0 kHz or 7.2 kHz by setting the sample rate bit field in Control Register 0. The TBIT and TBAUD clock rates are set by adjusting the appropriate bits in Control Register 3. The RBIT and RBAUD clock rates are set by adjusting the appropriate bits in Control Register 2. The bit and baud rates can be set to any combination of clock rates listed in the control register descriptions.

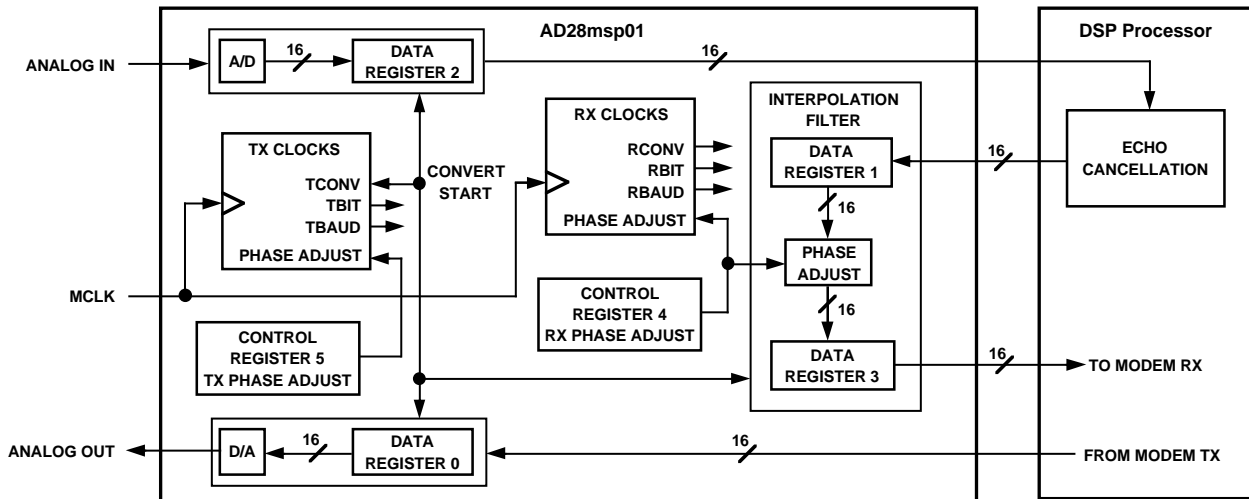

Figure 8. V.32 Internal Sync Mode Block Diagram

V.32 Loopback Mode

In V.32 Loopback Mode, shown in Figure 9, the AD28msp01's receive circuitry and transmit circuitry are locked together.

RCONV is generated internally and can be phase adjusted with the Receive Phase Adjust Register (Control Register 4). RBIT, RBAUD, TCONV, TBIT and TBAUD are all locked to RCONV.

RCONV initiates a new DAC sample update and loads Data Register 2 with a new sample. The RCONV rate can be set to 9.6 kHz, 8.0 kHz or 7.2 kHz by setting the sample rate bit field in Control Register 0. The bit and baud rates can be set to any combination of clock rates listed in the control register descriptions.

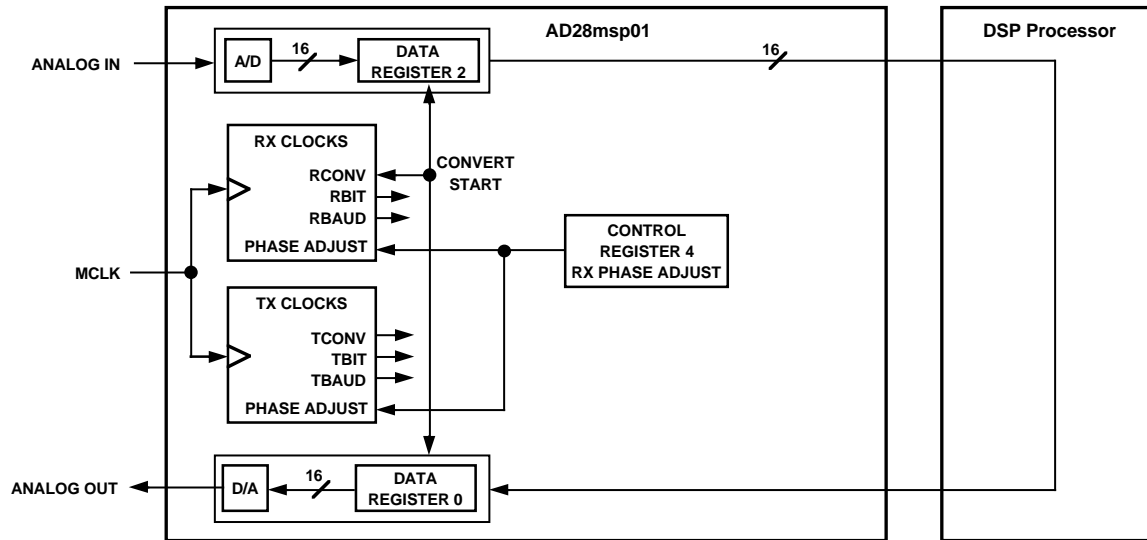

Figure 9. Loopback Mode Block Diagram

V.32ter TSYNC Mode

This mode is identical to V.32 TSYNC Mode except all clocks are scaled by a factor of 8/7 over the corresponding V.32 TSYNC rate. In this mode, the maximum value to which the receive and transmit phase adjust registers (Control Registers 4 and 5) may be set is +192.

Both TBIT and RBIT can be set to a 19,200 Hz rate that will not be scaled by a factor of 8/7, by setting the appropriate fields in Control Registers 2 and 3.

V.32ter Internal Sync Mode

This mode is identical to V.32 TSYNC Mode except all clocks are scaled by a factor of 8/7 over the corresponding V.32 TSYNC rate. In this mode, the maximum value to which the phase adjust registers (Control Registers 4 and 5) may be set is +192.

Both TBIT and RBIT can be set to a 19,200 Hz rate that will not be scaled by a factor of 8/7, by setting the appropriate fields in Control Registers 2 and 3.

AD28msp01

Asynchronous Fallback TSYNC Mode

The Asynchronous Fallback TSYNC Mode is shown in Figure 10. TCONV, TBIT and TBAUD are generated internally but phase locked to the external TSYNC input signal. RCONV, RBIT and RBAUD are generated internally and can be phase adjusted with the Receive Phase Adjust Register (Control Register 4).

This mode is entered by setting the Operating Mode field in Control Register 0. The RCONV/TCONV rate can be set to

9.6 kHz, 8.0 kHz or 7.2 kHz by setting the sample rate bit field in Control Register 0. The TBIT and TBAUD clock rates are set by adjusting the appropriate bits in Control Register 3. The RBIT and RBAUD clock rates are set by adjusting the appropriate bits in Control Register 2. The bit rates, baud rates and TSYNC rate can be set to any combination of clock rates listed in the control register descriptions.

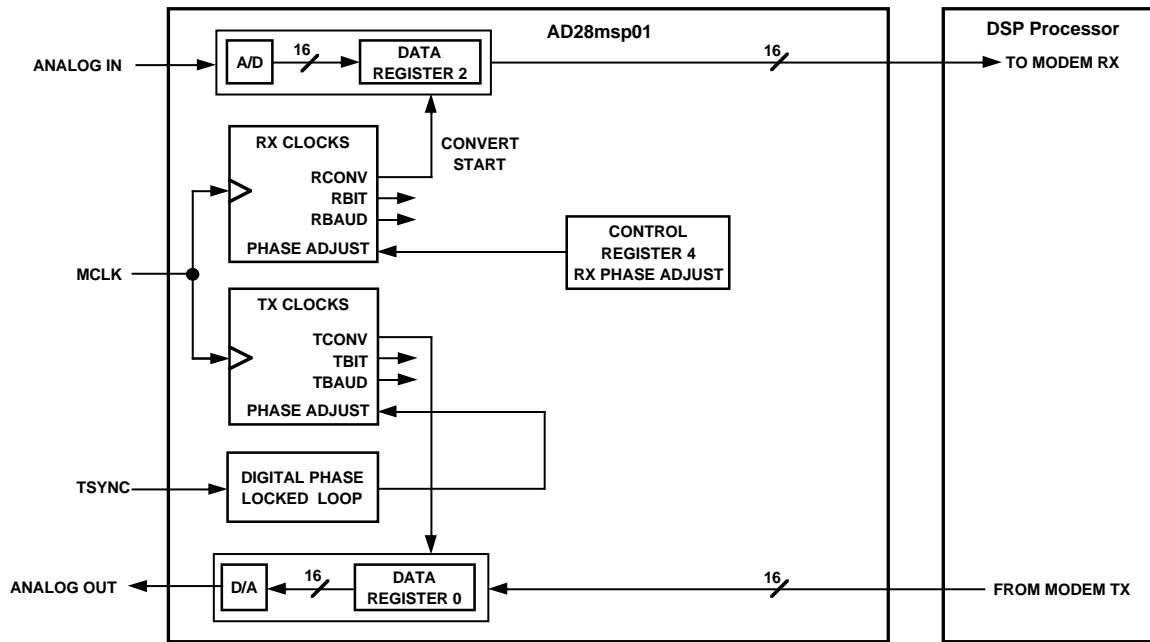

Figure 10. Asynchronous Fallback TSYNC Driven Mode Block Diagram

Asynchronous Fallback Mode

The Asynchronous Fallback Mode is shown in Figure 11. TCONV, TBIT and TBAUD are generated internally and can be phase adjusted with the Transmit Phase Adjust Register (Control Register 5). RCONV, RBIT and RBAUD are generated internally and can also be phase adjusted with the Receive Phase Adjust Register (Control Register 4). The digital phase-locked is not used in this operating mode.

This mode is entered by setting the Operating Mode field in Control Register 0. The RCONV/TCONV rate can be set to 9.6 kHz, 8.0 kHz or 7.2 kHz by setting the sample rate bit field in Control Register 0. The TBIT and TBAUD clock rates are set by adjusting the appropriate bits in Control Register 3. The RBIT and RBAUD clock rates are set by adjusting the appropriate bits in Control Register 2. The bit and baud rates can be set to any combination of clock rates listed in the control register descriptions.

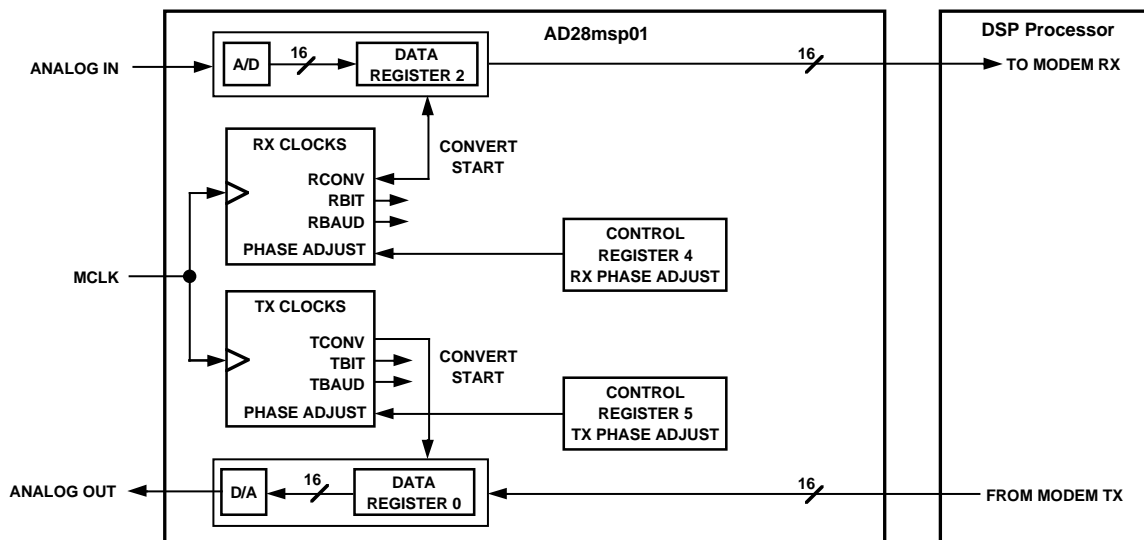

Figure 11. Asynchronous Fallback Mode Block Diagram

Operating Mode Summary

Table III summarizes the operating modes.

Table III. Operating Mode Summary

Mode	Initial Phase Lock After Entering Mode	Normal DPLL* Operation	Phase Adjust Register Programmable†	Resampling Interpolator	Internal Filter Operation Synchronous To:	Control Register 0 OP 2-0
					ADC DAC	
Async Fallback	no phase lock	no phase lock	RCV, TX	not used	RCONV TCONV	0 0 0
Async TSYNC	TCONV lock to TSYNC	TCONV lock to TSYNC	RCV	not used	RCONV TCONV	1 1 1
V.32 TSYNC	RCONV lock to TCONV	TCONV lock to TSYNC	RCV	Input synchronous and in phase with TCONV, Output synchronous and in phase with RCONV	TCONV TCONV	1 0 0
V.32 Internal Sync	RCONV lock to TCONV	no phase lock	RCV, TX	Input synchronous and in phase with TCONV, Output synchronous and in phase with RCONV	TCONV TCONV	1 0 1
V.32 Loopback	TCONV lock to RCONV	no phase lock	RCV††	not used	TCONV TCONV	1 1 0

NOTES

*DPLL—Digital Phase-Locked loop.

†RCV phase adjusted via Control Register 4, TX phase adjusted via Control Register 5.

††Adjusting RCV phase also adjusts TX phase in this mode.

Note: All receive clocks: RBIT, RBAUD are synchronous to RCONV. All transmit clocks: TBIT, TBAUD are synchronous to TCONV.

AD28msp01

DESIGN CONSIDERATIONS

Analog Input

The analog input signal to the AD28msp01 must be ac coupled. Figure 12 shows the recommended input circuit for the AD28msp01's analog input pin (V_{IN}). The circuit of Figure 12 implements a first-order low-pass filter with a 3 dB point at 20 kHz; this is the only filter that must be implemented external to the AD28msp01 to prevent aliasing of the sampled signal. Since the AD28msp01's ADC uses a highly oversampled approach that transfers the bulk of the anti-aliasing filtering into the digital domain, the off-chip anti-aliasing filter need only be of low order.

In the circuit shown in Figure 12, scaling of the analog input is achieved by the resistors R_{IN} and R_{FB} . The input signal gain, $-R_{FB}/R_{IN}$, can be adjusted by varying the values of these resistors. Total gain must be configured to ensure that a full-scale input signal (at C_{IN} in Figure 12) produces a signal level at the input to the sigma-delta modulator of the ADC that does not exceed V_{INMAX} , which is specified under "Analog Interface Electrical Characteristics." If the total gain is increased above unity (i.e., gain >1), signal-to-noise (SNR + THD) performance may not meet the listed specifications.

The dc offsetting of the analog input signal is accomplished with an on-chip voltage reference which nominally equals 2.5 V. The input signal must be ac coupled with an external coupling capacitor (C_{IN}). C_{IN} and R_{IN} should be chosen to ensure a coupling corner frequency of 30 Hz. C_{IN} should be 0.1 μ F or larger.

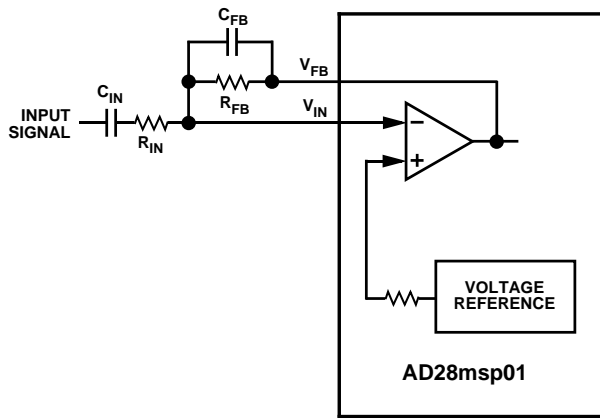

Figure 12. Recommended Analog Input Circuit

To select values for the components shown in Figure 12, use the following equations:

$$\text{Gain} = \frac{-R_{FB}}{R_{IN}}$$

$$C_{IN} = \frac{1}{60 \pi R_{IN}}$$

$$C_{FB} = \frac{1}{(2 \pi)(20 * 10^3) R_{FB}}$$

$$10 \text{ k}\Omega \leq R_{FB}, R_{IN} \leq 50 \text{ k}\Omega$$

$$150 \text{ pF} \leq C_{FB} \leq 600 \text{ pF}$$

Figure 13 shows an example of a typical input circuit configured for 0 dB gain. The circuit's diodes are used to prevent the input signal from exceeding maximum limits.

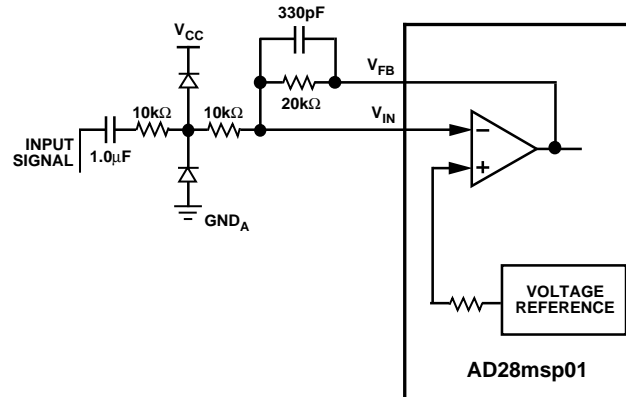

Figure 13. Typical Input Circuit (0 dB Gain)

Analog Output

The AD28msp01's differential analog output (V_{OUTP} , V_{OUTN}) is produced by an on-chip differential amplifier. The differential amplifier can drive a minimum load of 2 k Ω ($R_L \geq 2 \text{ k}\Omega$) and has a maximum differential output voltage swing of 6.312 V peak-to-peak (3.17 dBm0). The differential output can be ac-coupled directly to a load or dc-coupled to an external amplifier.

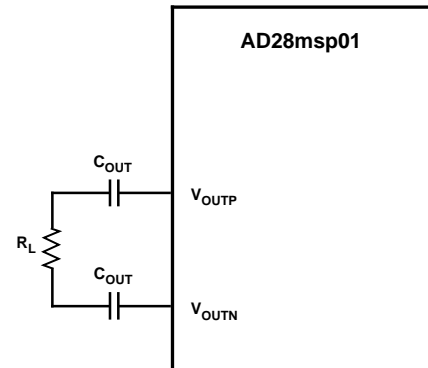

Figure 14. Example Circuit for Differential Output with AC Coupling

Figure 14 shows a simple circuit providing a differential output with ac coupling. The capacitor of this circuit (C_{OUT}) is optional; if used, its value can be chosen as follows:

$$C_{OUT} = \frac{1}{(60 \pi) R_L}$$

The V_{OUTP} - V_{OUTN} outputs must be used as differential outputs; do not use either as a single-ended output. Figure 15 shows an example circuit which can be used to convert the differential output to a single-ended output. The circuit uses a differential-to-single-ended amplifier, the Analog Devices SSM2141.

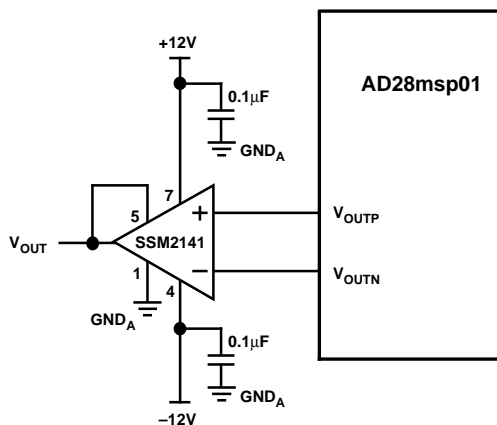

Figure 15. Example Circuit for Single-Ended Output

Single Power Supply Operation

Use of a single +5 V power supply is possible with the AD28msp01. If a single supply is used, the analog power supply input to the device must be properly filtered. The proper filter is dependent on the noise present in your system.

PC Board Layout Considerations

Separate analog and digital ground planes should be provided for the AD28msp01 in order to assure the characteristics of the device's ADC and DAC. The two ground planes should be connected only at a single point. The point of connection may be at the system power supply, at the PC board power connection, or at any other appropriate location. Multiple connections between the analog and digital ground planes should be avoided.

The ground planes should be designed such that all noise-sensitive areas are isolated from one another and critical signal traces (such as digital clocks and analog signals) are as short as possible.

Each +5 V supply pin of the AD28msp01 should be bypassed to ground with a 0.1 μF capacitor. These capacitors should be low inductance, monolithic, ceramic, and surface-mount. The capacitor leads and PC board traces should be as short as possible to minimize inductive effects. In addition, a 10 μF capacitor should be connected between V_{DD} and ground, near the PC board power connection.

MCLK Frequency

The sigma-delta converters and digital filters of the AD28msp01 are specifically designed to operate at a master clock (MCLK) frequency of 13.824 MHz. MCLK must equal 13.824 MHz to guarantee the filter characteristics and sample rate of the ADC and DAC. The AD28msp01 is not tested or characterized at any other clock frequency.

DEFINITION OF SPECIFICATIONS

Typical (Typ) specifications represent nominal performance at +25°C with V_{CC} and V_{DD} set to +5 V.

Minimum (Min) and Maximum (Max) specifications are guaranteed across the full operating range, however, devices are tested only at the indicated test conditions.

Absolute Gain

Absolute gain is a measure of converter gain for a known signal. Absolute gain is measured with a 1.0 kHz sine wave at 0 dBm. The absolute gain specification is used as a reference for gain tracking error specification.

Gain Tracking Error

Gain tracking error measures changes in converter output for different signal levels relative to an absolute signal level. The absolute signal level is 1 kHz at 0 dBm (equal to absolute gain). Gain tracking error at 0 dBm0 is 0 dB by definition.

SNR

Signal-to-noise ratio is defined to be the ratio of the rms value of the measured input signal to the rms sum of all the spectral components in the specified passband, excluding dc and harmonic components.

THD

Total harmonic distortion is defined to be the ratio of the rms value of the measured input signal to the rms sum of the harmonic components in the specified passband.

Intermodulation Distortion

With inputs consisting of sine waves at two frequencies, f_a and f_b , any active device with nonlinearities will create distortion products at sum and difference frequencies of $mf_a \pm nf_b$ where $m, n = 0, 1, 2, 3$, etc. Intermodulation terms are those for which neither m nor n are equal to zero. This specification contains the second order terms include $(f_a + f_b)$ and $(f_a - f_b)$, and the third order terms include $(2f_a + f_b)$, $(2f_a - f_b)$, $(f_a + 2f_b)$, and $(f_a - 2f_b)$.

Idle Channel Noise

Idle channel noise is defined as the total signal energy measured at the output of the device when the input is grounded (measured in the specified passband).

Crosstalk

Crosstalk is defined as the ratio of the amplitude of a 0 dB signal appearing on one channel to the amplitude of the same signal coupled onto the other, idle channel. Crosstalk is expressed in dB.

Power Supply Rejection

Power supply rejection measures the susceptibility of a device to noise on the power supply. Power supply rejection is measured by modulating the power supply with a 1 kHz, 100 mV p-p sine wave and measuring the relative level at the output.

Group Delay

Group delay is defined as the derivative of radian phase with respect to radian frequency, $\partial\phi(\omega)/\partial\omega$. Group delay is a measure of the linearity of the phase response of a linear system. A linear system with a constant group delay has a linear phase response. The deviation of the group delay away from a constant indicates the degree of nonlinear phase response of the system.

AD28msp01—SPECIFICATIONS

RECOMMENDED OPERATING CONDITIONS

Symbol	Parameter	K Grade		Unit
		Min	Max	
V_{DD}, V_{CC}	Supply Voltage	4.75	5.25	V
T_{AMB}	Ambient Operating Temperature	0	+70	°C

Refer to Environmental Conditions for information on case temperature and thermal specifications.

ABSOLUTE MAXIMUM RATINGS*

Supply Voltage	−0.3 V to +7 V
Input Voltage	−0.3 V to $V_{DD} + 0.3$ V
Output Voltage Swing	−0.3 V to $V_{DD} + 0.3$ V
Operating Temperature Range (Ambient)	0°C to +70°C
Storage Temperature Range	−55°C to +150°C
Lead Temperature (5 seconds) SOIC	+280°C

*Stresses above those listed under “Absolute Maximum Ratings” may cause permanent damage to the device. These are stress rating only and functional operation of the device at these or any other conditions above those indicated in the operational sections of this specification is not implied. Exposure to absolute maximum rating conditions for extended periods may affect device reliability.

Test Conditions Unless Otherwise Noted

Temperature	+25°C
Sample Rate (F_S)	9.6 kHz
Input Signal Frequency	993.75 Hz
Input Signal Level	0.0 dBm0
Analog Input Gain	Unity
Analog Output Passband	220 Hz to 3.4 kHz

ESD SENSITIVITY

The AD28msp01 features proprietary input protection circuitry to dissipate high-energy discharges (Human Body Model). Per Method 3015 of MIL-STD-883 the AD28msp01 has been classified as a Class 1 device.

Proper ESD precautions are strongly recommended to avoid functional damage or performance degradation. Charges readily accumulate on the human body and test equipment and discharge without detection. Unused devices must be stored in conductive foam, trays, or tubes, and the foam should be discharged to the destination socket before devices are removed.



DIGITAL INTERFACE ELECTRICAL CHARACTERISTICS

Symbol	Parameter	Min	Typ	Max	Unit	Test Condition
V _{IH}	Input High Voltage	2.4			V	V _{DD} = max
V _{IL}	Input Low Voltage			0.8	V	V _{DD} = min
V _{OH}	Output High Voltage	2.4			V	V _{DD} = min, I _{OH} = -0.5 mA
V _{OL}	Output Low Voltage			0.4	V	V _{DD} = min, I _{OL} = 2 mA
I _{IH}	High Level Input Current			10	μA	V _{DD} = max, V _{IN} = max
I _{IL}	Low Level Input Current			10	μA	V _{DD} = max, V _{IN} = 0 V
I _{OZL}	Low Level Output 3-State Leakage Current			10	μA	V _{DD} = max, V _{IN} = max
I _{OZH}	High Level Output 3-State Leakage Current			10	μA	V _{DD} = max, V _{IN} = 0 V
C _I	Digital Input Capacitance ¹			10	pF	

¹Guaranteed but not tested.

ANALOG INTERFACE ELECTRICAL CHARACTERISTICS

Symbol	Parameter	Min	Typ	Max	Unit
ADC:					
I _L	Input Leakage Current at V _{IN}		10		nA
R _I	Input Resistance at V _{IN}		100		MΩ
C _{IL}	Input Load Capacitance at V _{FB}		10		pF
V _{INMAX}	Maximum Input Range ¹		3.156		V p-p
DAC:					
R _o	Output Resistance		1		Ω
V _{OFF}	Output DC Offset ²	-400		400	mV
C _{OL}	Output Load Capacitance			100	pF
V _O	Maximum Voltage Output Swing (p-p) Across R _L				
	Single-Ended		3.156		V
	Differential		6.312		V
R _L	Load Resistance	2			kΩ

Test Conditions for all analog interface tests: Unity input gain, no load on analog output (V_{OUTP}-V_{OUTN}).

¹At unity gain on input.

²Between V_{OUTP} and V_{OUTN}.

POWER DISSIPATION

Symbol	Parameter	Min	Typ	Max	Unit
V _{CC}	Analog Operating Voltage	4.75	5.0	5.25	V
V _{DD}	Digital Operating Voltage	4.75	5.0	5.25	V
I _{CC}	Analog Operating Current Active ¹		24	35	mA
I _{DD}	Digital Operating Current Active ¹		11	20	mA
P ₁	Power Dissipation Active ¹			350	mW
I _{CC}	Analog Operating Current Inactive ²			300	μA
I _{DD}	Digital Operating Current Inactive ²			200	μA
P ₀	Power Dissipation Inactive ²			4.0	mW

Test conditions: V_{DD} = V_{CC} = 5.0 V, MCLK frequency 13.824 MHz, no load on digital pins, analog inputs ac-coupled to ground, no load on analog output (V_{OUTP}-V_{OUTN}).

¹Active: AD28msp01 operational (PWDD and PWDA set to 1 in Control Register 1).

²Inactive: AD28msp01 in power-down state (PWDD and PWDA set to 0 in Control Register 1) and MCLK tied to V_{DD}.

AD28msp01

TIMING PARAMETERS

Parameter		Min	Max	Unit
Clock Signals				
<i>Timing Requirement:</i>				
F_{MCK}	MCLK Frequency	13.824	13.824	MHz \pm 50 ppm
t_{MCK}	MCLK Period	72.34	72.34	ns
t_{MKL}	MCLK Width Low	$0.5t_{MCK} - 10$	$0.5t_{MCK} + 10$	ns
t_{MKH}	MCLK Width High	$0.5t_{MCK} - 10$	$0.5t_{MCK} + 10$	ns
<i>Switching Characteristic:</i>				
t_{SCK}	SCLK Period	$8t_{MCK} - 10$	$8t_{MCK} + 10$	ns
t_{SKL}	SCLK Width Low	$4t_{MCK} - 10$	$4t_{MCK} + 10$	ns
t_{SKH}	SCLK Width High	$4t_{MCK} - 10$	$4t_{MCK} + 10$	ns
Control Signals				
<i>Timing Requirement:</i>				
t_{RSP}	$\overline{\text{RESET}}$ Width Low	$5t_{MCK}^1$		ns

NOTE

¹Applies after power-up sequence is complete. Internal phase lock loop requires no more than 1000 processor cycles assuming stable CLKIN (not including crystal oscillator start-up time).

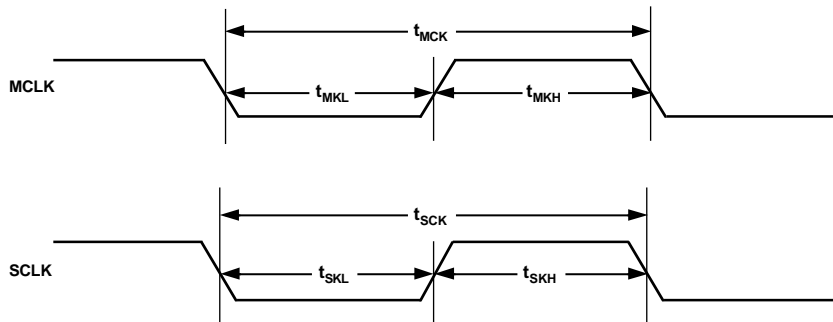

Figure 16. Clock Signals

Serial Port 3-State

Parameter		Min	Max	Unit
<i>Switching Characteristic:</i>				
t_{SPD}	CS Low to SDO, SDOFS, SCLK Disable		20	ns
t_{SPE}	CS High to SDO, SDOFS, SCLK Enable	0		ns
t_{SPV}	CS High to SDO, SDOFS, SCLK Valid		25	ns

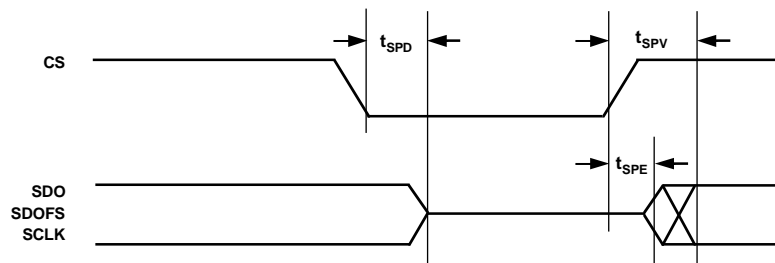

Figure 17. Serial Port 3-State

Output Disable Time

Output pins are considered to be disabled when they have stopped driving and started a transition from the measured output high or low voltage to a high-impedance state. The output disable time (t_{DIS}) is the difference of $t_{MEASURED}$ and t_{DECAY} , as shown in the Output Enable/Disable diagram. The time, $t_{MEASURED}$, is the interval from when a reference signal reaches a high or low voltage level to when the output voltages have changed by 0.5 V from the measured output high or low voltage. The decay time, t_{DECAY} , is dependent on the capacitive load, C_L , and the current load, i_L , on the output pin. It can be approximated by the following equation:

$$t_{DECAY} = \frac{C_L \times 0.5 V}{i_L}$$

from which

$$t_{DIS} = t_{MEASURED} - t_{DECAY}$$

is calculated. If multiple pins (such as the data bus) are disabled, the measurement value is that of the last pin to stop driving.

Output Enable Time

Output pins are considered to be enabled when they have made a transition from a high-impedance state to when they start driving. The output enable time (t_{ENA}) is the interval from when a reference signal reaches a high or low voltage level to when the output has reached a specified high or low trip point, as shown in the Output Enable/Disable diagram. If multiple pins (such as the data bus) are enabled, the measurement value is that of the first pin to start driving.

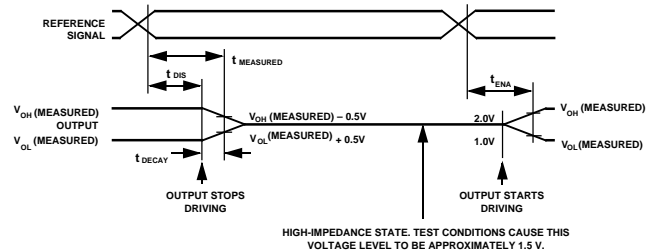

Figure 18. Output Enable/Disable

Serial Ports

Parameter		Min	Max	Unit
<i>Timing Requirement:</i>				
t_{SCS}	SDI/SDIFS Setup before SCLK Low	10		ns
t_{SCH}	SDI/SDIFS Hold after SCLK Low	15		ns
<i>Switching Characteristic:</i>				
t_{RD}	SDOFS Delay from SCLK High		30	ns
t_{RH}	SDOFS Hold after SCLK High	0		ns
t_{SCDH}	SDO Hold after SCLK High	0		ns
t_{SCDD}	SDO Delay from SCLK High		30	ns

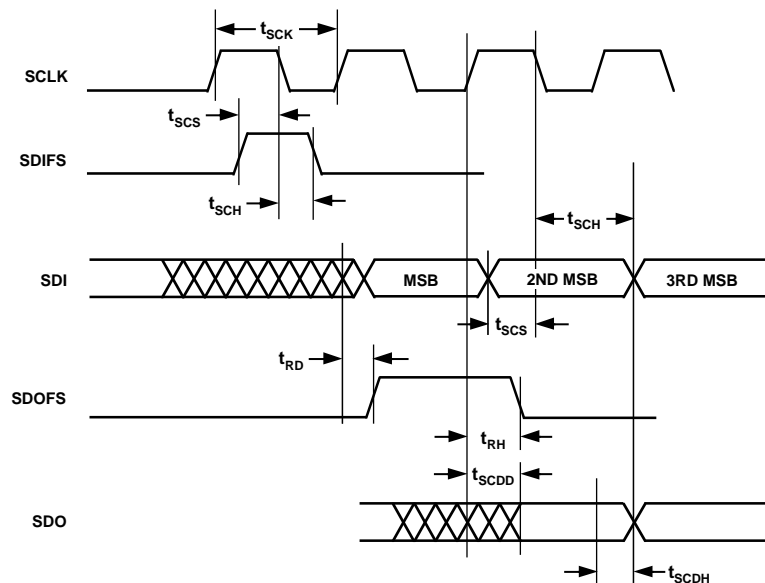

Figure 19. Serial Ports

AD28msp01

DIGITAL TEST CONDITIONS

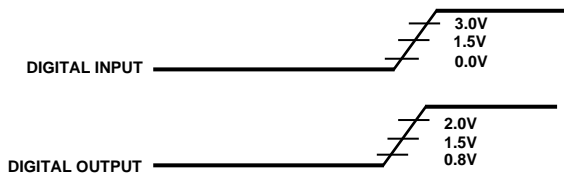

Figure 20. Voltage Reference Levels for AC Measurements (Except Output Enable/Disable)

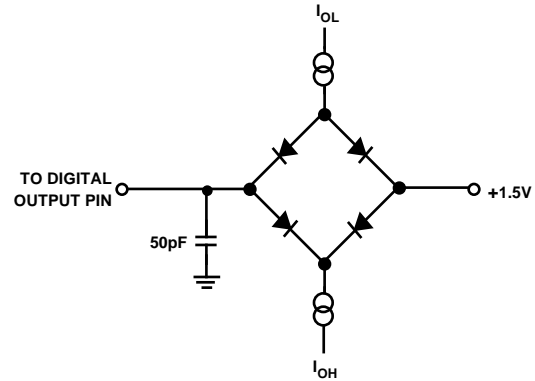

Figure 21. Equivalent Device Loading for AC Measurements (Includes ALL Fixtures)

GAIN

Parameter	Min	Typ	Max	Unit	Test Conditions
ADC Absolute Gain	-0.5	0	0.5	dBm0	1.0 kHz, 0 dBm0
ADC Gain Tracking Error	-0.1	0	0.1	dBm0	1.0 kHz, +3 and -60 dBm0
DAC Absolute Gain	-0.5	0	0.5	dBm0	1.0 kHz, 0 dBm0
DAC Gain Tracking Error	-0.1	0	0.1	dBm0	1.0 kHz, +3 and -60 dBm0

FREQUENCY RESPONSE*

ADC	9.6 kHz	8.0 kHz	7.2 kHz
Passband Ripple	<0.2 dB	<0.2 dB	<0.2 dB
Low-Pass Passband Cutoff Frequency	3.4 kHz	3.4 kHz	3.3 kHz
Low-Pass Stopband Cutoff Frequency	4.8 kHz	4.0 kHz	3.6 kHz
High-Pass Passband Cutoff Frequency	220 Hz	220 Hz	220 Hz
High-Pass Stopband Cutoff Frequency	60 Hz	60 Hz	60 Hz
Low-Pass Stopband Rejection	-50 dB	-50 dB	-50 dB
High-Pass Stopband Rejection	-50 dB	-50 dB	-50 dB
DAC	9.6 kHz	8.0 kHz	7.2 kHz
Passband Ripple	<0.2 dB	<0.2 dB	<0.2 dB
Passband Cutoff Frequency	3.4 kHz	3.4 kHz	3.4 kHz
Low-Pass Stopband Cutoff Frequency	4.8 kHz	4.0 kHz	3.6 kHz
Stopband Rejection	-50 dB	-50 dB	-50 dB

*Frequency Response is guaranteed but not tested.

NOISE AND DISTORTION

Parameter	Min	Typ	Max	Unit
ADC Signal-to-Noise Ratio	+72	+80		dB
ADC Total Harmonic Distortion			-72	dB
DAC Signal-to-Noise Ratio	+72	+80		dB
DAC Total Harmonic Distortion			-72	dB
ADC Idle Channel Noise		-80	-72	dBm0
DAC Idle Channel Noise		-80	-72	dBm0
ADC Crosstalk ¹			-72	dB
DAC Crosstalk ¹			-72	dB
ADC Intermodulation Distortion ¹				dB
DAC Intermodulation Distortion ¹			-72	dB
ADC Digital Power Supply Rejection ¹			-45	dB
DAC Digital Power Supply Rejection ¹			-45	dB
ADC Analog Power Supply Rejection ¹			-35	dB
DAC Analog Power Supply Rejection ¹			-35	dB

¹Guaranteed but not tested

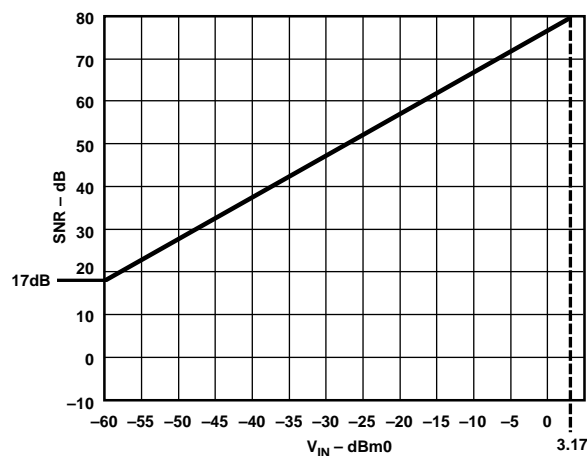

Figure 22. Typical SNR vs. V_{IN}

GROUP DELAY*

	9.6 kHz	8.0 kHz	7.2 kHz	Unit
ADC Group Delay	12	13	15	ms
ADC Low-Pass Filter Group Delay	2	3	5	ms
ADC High-Pass Filter Group Delay	10	10	10	ms
DAC Group Delay	2	3	5	ms
Resampling Filter Group Delay	2	3	5	ms

*Group Delay is guaranteed but not tested.

AD28msp01

PIN CONFIGURATIONS

28-Pin DIP and 28-Lead SOIC

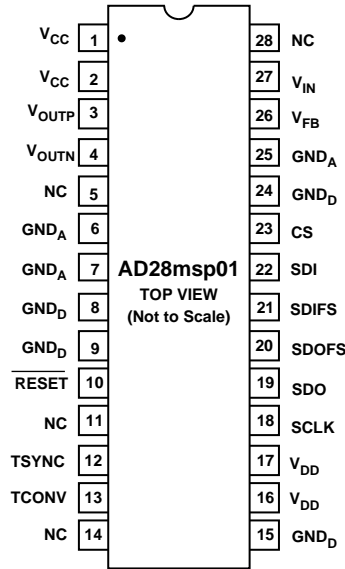

NC = NO CONNECT

44-Lead Plastic Leaded Chip Carrier (PLCC)

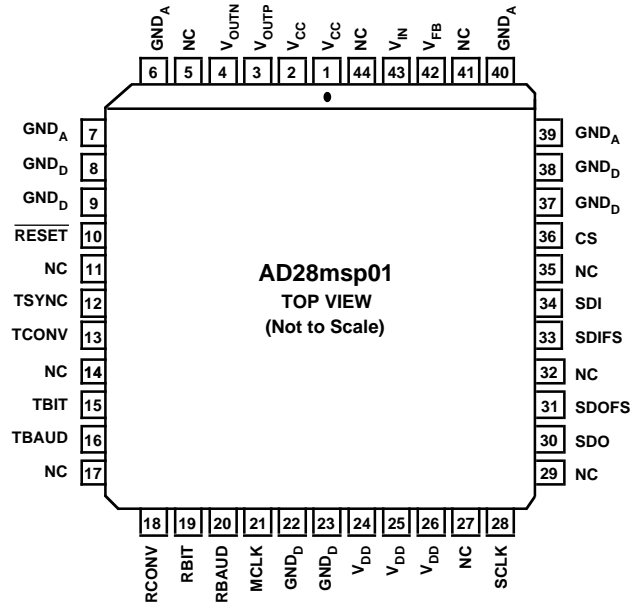

NC = NO CONNECT

44-Lead Thin Quad Flat Pack

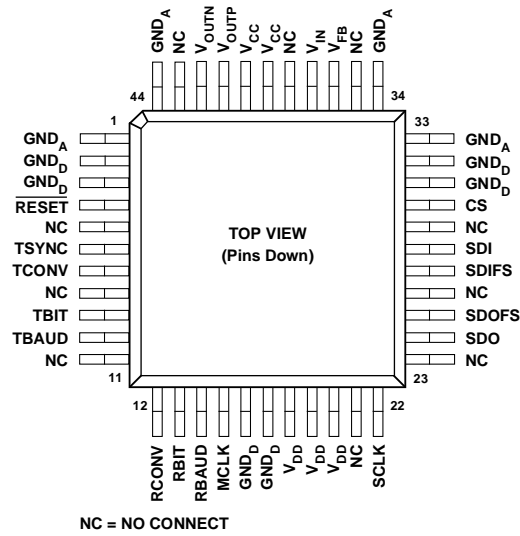

OUTLINE DIMENSIONS

Dimensions shown in inches and (mm).

N-28 28-Pin Plastic DIP

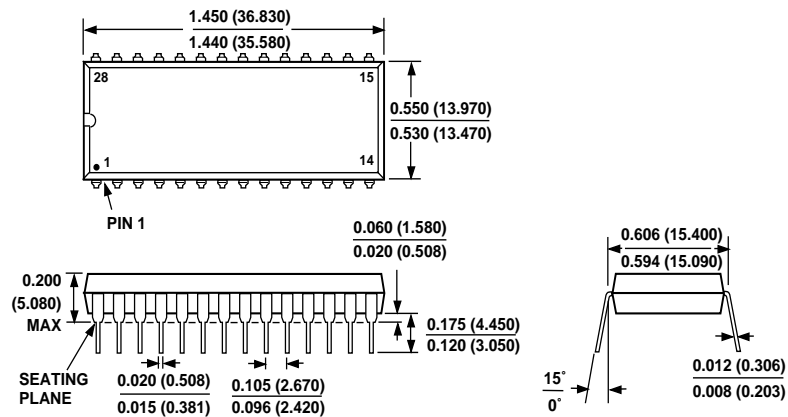

P-44A 44-Lead Plastic Leaded Chip Carrier (PLCC)

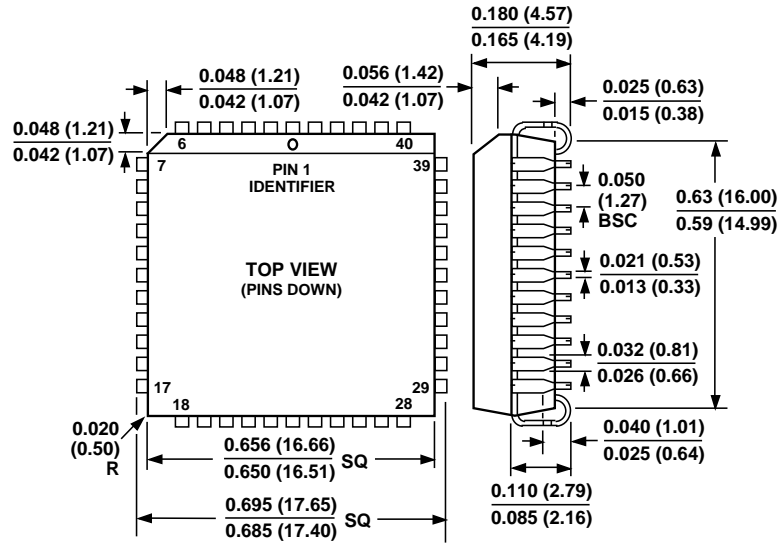

R-28 28-Lead Wide-Body SOIC

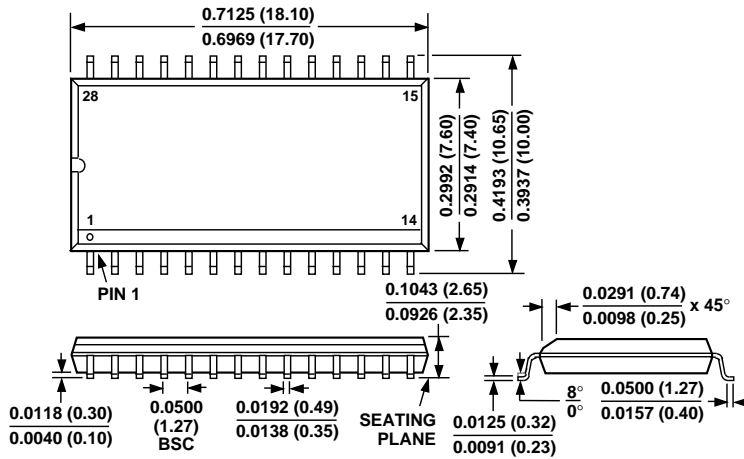

ST-44
44-Lead Metric Thin Plastic Quad Flat Pack (TQFP)

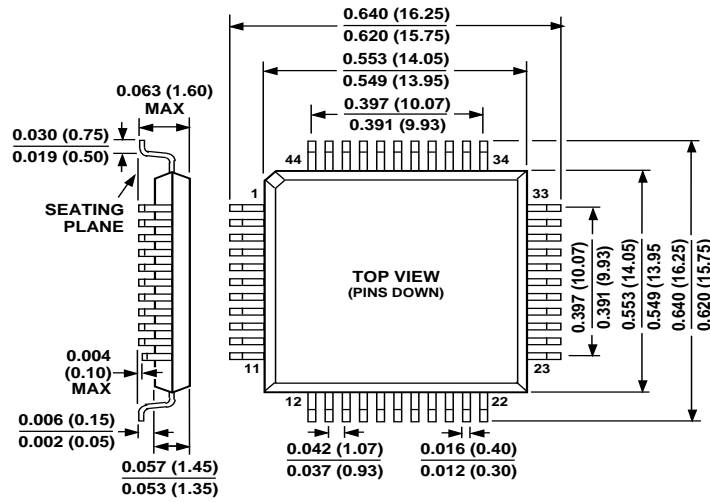

ORDERING GUIDE

Part Number	Temperature Range	Package	Package Option*
AD28msp01KP	0°C to +70°C	44-Pin PLCC	P-44A
AD28msp01KN	0°C to +70°C	28-Pin Plastic DIP	N-28
AD28msp01KR	0°C to +70°C	28-Lead SOIC	R-28
AD28msp01KST†	0°C to +70°C	44-Lead TQFP	ST-44

NOTES

*P = PLCC, N = Plastic DIP, R = Small Outline (SOIC), ST = TQFP.

†In Development.



LittleDiode supplies new, hard to find or obsolete electronic components and semiconductors all over the world.

With over two million different components listed you are sure to find the part you need.

Feel free to visit us today at our online store:

LittleDiode.com

Looking forward to providing you with the best possible service.